



**Economic and Social  
Council**

Distr.  
GENERAL

ECE/TRANS/WP.29/GRE/2008/28  
11 July 2008

Original: ENGLISH  
ENGLISH AND FRENCH ONLY

---

**ECONOMIC COMMISSION FOR EUROPE**

INLAND TRANSPORT COMMITTEE

World Forum for Harmonization of Vehicle Regulations

Working Party on Lighting and Light-Signalling

Sixtieth session

Geneva, 1 - 3 October 2008

Item 3(a) of the provisional agenda

REGULATION No. 37  
(Filament lamps)

Proposal for Supplement 33 to the 03 series of amendments to Regulation No. 37

Submitted by the expert from India \*/

The text reproduced below was prepared by the expert from India in order to introduce into Regulation No. 37 new P18/5W, PR18/5W and W10W light source categories for signalling lamps. The proposal is based on a document without symbol (informal document No. GRE-59-42), distributed during the fifty-ninth GRE session (see report ECE/TRANS/WP.29/GRE/59, para. 6). The proposal is based on the current text of the Regulation including draft Supplement 32 to the 03 series of amendments (ECE/TRANS/WP.29/2008/84). The modifications to the existing text of the Regulation are marked in bold characters.

---

\*/ In accordance with the programme of work of the Inland Transport Committee for 2006-2010 (ECE/TRANS/166/Add.1, programme activity 02.4), the World Forum will develop, harmonize and update Regulations in order to enhance performance of vehicles. The present document is submitted in conformity with that mandate.

A. PROPOSAL

The list of contents, the annexes, amend to read:

Annex 1,

The list of categories of filament lamps, grouped, and their sheet numbers, amend to read:

"Group 2:

Only for use in signalling lamps, cornering lamps, reversing lamps and rear registration plate lamps:

<u>Category</u>	<u>Sheet number(s)</u>
C5W	C5W/1
....	....
P13W	P13W/1 to 3
<b>P18/5W</b>	<b>P18/5W/1 to 3</b>
<b>PR18/5W</b>	<b>PR18/5W/1</b>
P19W	P19W/1 to 3
....	....
W5W	W5W/1
<b>W10W</b>	<b>W10W/1</b>
W15/5W	W15/5W/1 to 3
W16W	W16W/1
....	...."

The list of sheets for filament lamps and their sequence, amend to read:

"

<u>Sheet number(s)</u>
....
C5W/1
....
P13W/1 to 3
<b>P18/5W/1 to 3</b>
<b>PR18/5W/1</b>
P19W/1 to 3
....
W5W/1
<b>W10W/1</b>
W15/5W/1 to 3
W16W/1
...."

Insert new sheets P18/5W/1 to 3, between sheet P13W/1 to 3 and sheet PR18/5W/1, to read:  
(see next pages).

"

CATEGORIES P18/5W

Sheet P18/5W /1

The drawings are intended only to illustrate the essential dimensions (in mm) of the filament lamp

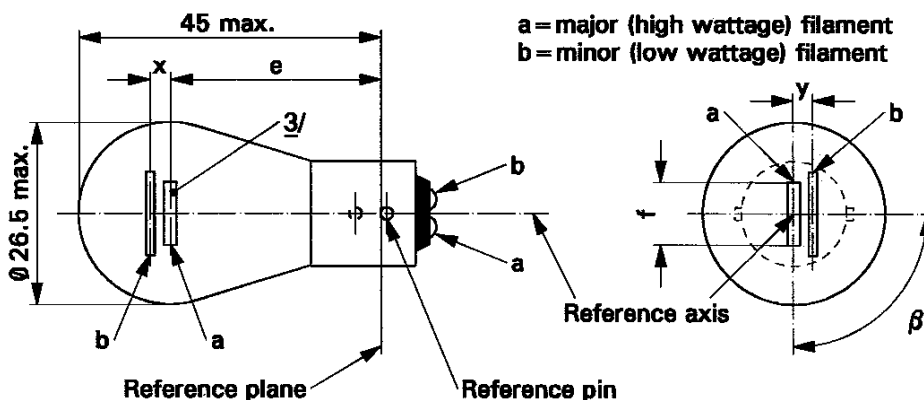

Dimensions in mm		Filament lamps of normal production			Standard filament lamp			
		min.	nom.	max.				
e	6, 12 V		31.8 <u>1/</u>		31.8 ± 0.3			
	24 V	30.8	31.8	32.8				
f	6, 12 V			7.0	7.0 + 0/- 2			
Lateral deviation <u>2/</u>	6, 12 V			<u>1/</u>	0.3 max.			
	24 V			1.5				
x, y	6, 12 V		<u>1/</u>		2.8 ± 0.3			
x	24 V <u>3/</u>	-1.0	0	1.0				
y	24 V <u>3/</u>	1.8	2.8	3.8				
$\beta$		75°	90°	105°	90° ± 5°			
Cap BAY15d in accordance with IEC Publication 60061 (sheet 7004-11B-7)								
ELECTRICAL AND PHOTOMETRIC CHARACTERISTICS								
Rated values	Volts	6		12		24		12
	Watts	18	5	18	5	18	5	18/5
Test voltage	Volts	6.75		13.5		28.0		13.5
Objective values	Watts	24.5 max.	6.6 max.	23.5 max.	6.6 max.	26.7 max.	11 max.	23.5 and 6.6 max.
	Luminous flux	325	35	325	35	325	40	
	± %	15	20	15	20	15	20	
Reference luminous flux: 325 and 35 lm at approximately 13.5 V								

For the notes see sheet P18/5W/2.

## CATEGORIES P18/5W

Sheet P18/5W /2

### Notes

- 1/ These dimensions shall be checked by means of a "box-system". See sheets P18/5W/2 and P18/5W/3. "x" and "y" refer to the major (high-wattage) filament, not to the reference axis.
- 2/ Maximum lateral deviation of the major (high wattage) filament centre from two mutually perpendicular planes both containing the reference axis and one containing the axis of the reference pin.
- 3/ In this view the filaments of the 24 V type may be straight or V-shaped. This shall be indicated in the application of approval. If the filaments are straight, the screen projection requirements apply. If they are V-shaped, the ends of each filament shall be at the same distance within  $\pm 3$  mm from the reference plane.

### Screen projection requirements

This test is used to determine, by checking whether:

- (a) the major (high wattage) filament is correctly positioned relative to the reference axis and reference plane and has an axis perpendicular, within  $\pm 15^\circ$ , to the plane through the centres of the pins and the reference axis; and whether
- (b) the minor (low wattage) filament is correctly positioned relative to the major (high wattage) filament, whether a filament lamp complies with the requirements.

### Test procedure and requirements

1. The filament lamp is placed in a holder capable of being rotated about its axis and having either a calibrated scale or fixed stops corresponding to the angular displacement tolerance limits. (i.e.  $15^\circ$ ). The holder is then so rotated that an end view of the major filament is seen on the screen on which the image of the filament is projected. The end view of that filament shall be obtained within the angular displacement tolerance limits.
2. Side elevation  
The filament lamp placed with the cap down, the reference axis vertical, the reference pin to the right and the major filament seen end-on:
  - 2.1. the projection of the major filament shall lie entirely within a rectangle of height "a" and width "b", having its centre at the theoretical position of the centre of the filament;
  - 2.2. the projection of the minor filament shall lie entirely:
    - 2.2.1. within a rectangle of width "c" and height "d" having its centre at a distance "v" to the right of and at a distance "u" above the theoretical position of the centre of the major filament;
    - 2.2.2. above a straight line tangential to the upper edge of the projection of the major filament and rising from left to right at an angle of  $25^\circ$ ;
    - 2.2.3. to the right of the projection of the major filament.
3. Front elevation  
The filament lamp being placed with the cap down and the reference axis vertical, the filament lamp being viewed in a direction at right angles to axis of the major filament:
  - 3.1. the projection of the major filament shall lie entirely within a rectangle of height "a" and width "h", centred on the theoretical position of the centre of the filament;
  - 3.2. the centre of the major filament shall not be offset by more than distance "k" from the reference axis.
  - 3.3. the centre of the minor filament axis shall not be offset from the reference axis by more than  $\pm 2$  mm ( $\pm 0.4$  mm for standard filament lamps).

Dimensions in mm

Side elevation

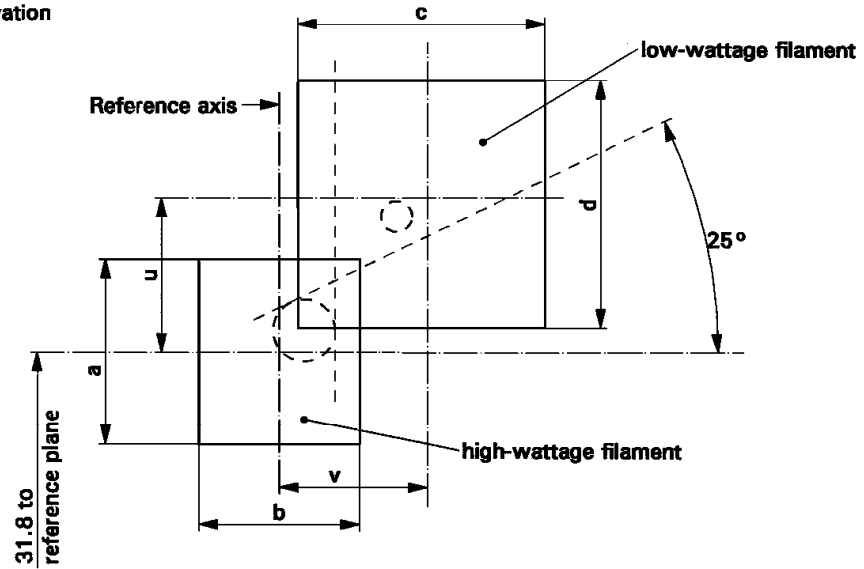

Reference	a	b	c	d	u	v
Dimensions	3.5	3.0	4.8		2.8	

Front elevation

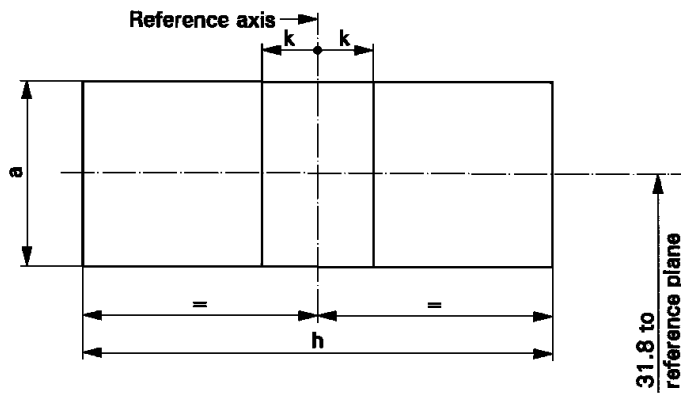

Reference	a	h	k
Dimensions	3.5	9.0	1.0

Insert a new sheet PR18/5W/1, between sheet P18/5W/1 to 3 and sheet P19W/1 to 3, to read:

"

CATEGORY PR18/5W

Sheet PR18/5W/1

The drawings are intended only to illustrate the essential dimensions (in mm) of the filament lamp

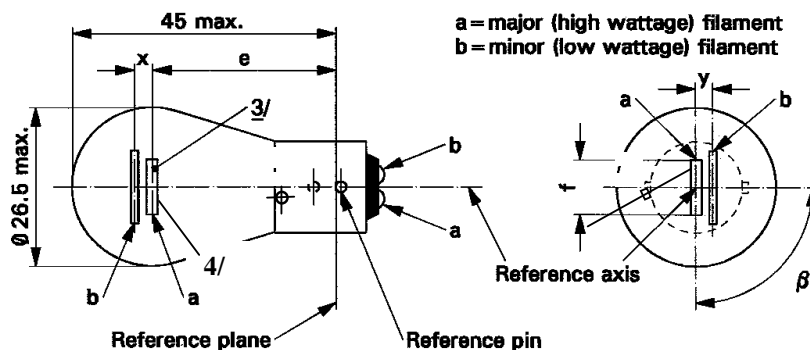

Dimensions in mm		Filament lamps of normal production <u>4/</u>			Standard filament lamp
		min.	nom.	max.	<u>5/</u>
e	12 V		31.8 <u>1/</u>		31.8 ± 0.3
	24 V	30.8	31.8	32.8	
f	12 V			7.0	7.0 + 0/- 2
Lateral deviation <u>2/</u>	12 V			<u>1/</u>	0.3 max.
	24 V			1.5	
x, y	12 V		<u>1/</u>		2.8 ± 0.3
x	24 V <u>3/</u>	-1.0	0	1.0	
y	24 V <u>3/</u>	1.8	2.8	3.8	
β		75°	90°	105°	90° ± 5°

Cap BAW15d in accordance with IEC Publication 60061 (sheet 7004-11E-1)

**ELECTRICAL AND PHOTOMETRIC CHARACTERISTICS**

Rated values	Volts	12		24		12
	Watts	18	5	18	5	18/5
Test voltage	Volts	13.5		28.0		13.5
Objective values	Watts	23.5 max.	6.6 max.	26.7 max.	11 max.	23.5 and 6.6 max.
	Luminous flux ± %	76	8	76	10	
Reference luminous flux at approximately 13.5 V:		White: 325 lm and 35 lm		Red: 76 lm and 8 lm		

1/ See footnote 1/ on sheet P18/5W/2.

2/ See footnote 2/ on sheet P18/5W/2.

3/ See footnote 3/ on sheet P18/5W/2.

- 4/ The light emitted from normal production lamps shall be red (see also note 5/).  
5/ The light emitted from standard filament lamps shall be white or red."

Insert a new sheet W10W/1, between sheet W5W/1 and sheet W16W/1, to read:

" **CATEGORY W10W** **Sheet W10W/1**

The drawings are intended only to illustrate the essential dimensions (in mm) of the filament lamp

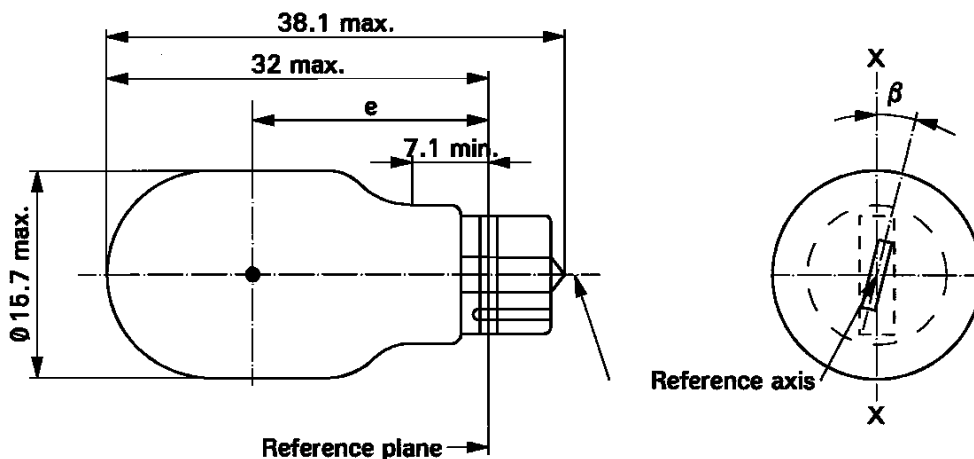

Dimensions in mm		Filament lamps of normal production			Standard filament lamp
		min.	nom.	max.	
e		18.3	20.6	22.9	20.6 ± 0.3
Lateral deviation	<u>1/</u>			1.0	0.5 max.
β		-15°	0°	+ 15°	0° ± 5°
Cap W2.1x9.5d in accordance with IEC Publication 60061 (sheet 7004-91-3)					
<b>ELECTRICAL AND PHOTOMETRIC CHARACTERISTICS</b>					
Rated values	Volts	12			12
	Watts	10			10
Test voltage	Volts	13.5			13.5
Objective values	Watts	11 max.			11 max.
	Luminous flux	125 ± 20 %			
Reference luminous flux: 125 lm at approximately 13.5 V					

1/ Maximum lateral deviation of filament centre from two mutually perpendicular planes both containing the reference axis and one containing axis X-X."

B. JUSTIFICATION

This proposal is intended to introduce into Regulation No. 37 new P18/5W, PR18/5W and W10W light source categories for signalling lamps.

P18/5W and PR18/5W would be suitable alternatives to P21/5W and PR21/5W respectively for use in Stop/rear position lamp for 2 wheelers. It will be possible to meet the photometric requirements with 18W filament (5:1 ratio of relative brightness). In the case of reduction in wattage of lamps, it will be of considerable advantage in designing the magneto, and system for regulating battery charging.

The proposed W10W lamp category can be used for signalling lamps such as direction indicator lamp, position lamp, etc. as a wedge-based alternative to R10W.

-----