

PART 2

Classification

CHAPTER 2.1

GENERAL PROVISIONS

2.1.1 Introduction

2.1.1.1 The classes of dangerous goods according to ADR are the following:

Class 1	Explosive substances and articles
Class 2	Gases
Class 3	Flammable liquids
Class 4.1	Flammable solids, self-reactive substances and solid desensitized explosives
Class 4.2	Substances liable to spontaneous combustion
Class 4.3	Substances which, in contact with water, emit flammable gases
Class 5.1	Oxidizing substances
Class 5.2	Organic peroxides
Class 6.1	Toxic substances
Class 6.2	Infectious substances
Class 7	Radioactive material
Class 8	Corrosive substances
Class 9	Miscellaneous dangerous substances and articles

2.1.1.2 Each entry in the different classes has been assigned a UN number. The following types of entries are used:

A. Single entries for well defined substances or articles including entries for substances covering several isomers, e.g.:

UN No. 1090	ACETONE
UN No. 1104	AMYL ACETATES
UN No. 1194	ETHYL NITRITE SOLUTION

B. Generic entries for a well defined group of substances or articles, which are not n.o.s. entries, e.g.:

UN No. 1133	ADHESIVES
UN No. 1266	PERFUMERY PRODUCTS
UN No. 2757	CARBAMATE PESTICIDE, SOLID, TOXIC
UN No. 3101	ORGANIC PEROXIDE TYPE B, LIQUID

C. Specific n.o.s. entries covering a group of substances or articles of a particular chemical or technical nature, not otherwise specified, e.g.:

UN No. 1477	NITRATES, INORGANIC, N.O.S.
UN No. 1987	ALCOHOLS, N.O.S.

D. General n.o.s. entries covering a group of substances or articles having one or more dangerous properties, not otherwise specified, e.g.:

UN No. 1325	FLAMMABLE SOLID, ORGANIC, N.O.S.
UN No. 1993	FLAMMABLE LIQUID, N.O.S.

The entries defined under B., C. and D. are defined as collective entries.

2.1.1.3 For packing purposes, substances other than those of Classes 1, 2, 5.2, 6.2 and 7, and other than self-reactive substances of Class 4.1 are assigned to packing groups in accordance with the degree of danger they present:

Packing group I: Substances presenting high danger;
Packing group II: Substances presenting medium danger;
Packing group III: Substances presenting low danger.

The packing group(s) to which a substance is assigned is (are) indicated in Table A of Chapter 3.2.

2.1.2 Principles of classification

2.1.2.1 The dangerous goods covered by the heading of a class are defined on the basis of their properties according to sub-section 2.2.x.1 of the relevant class. Assignment of dangerous goods to a class and a packing group is made according to the criteria mentioned in the same sub-section 2.2.x.1. Assignment of one or several subsidiary risk(s) to a dangerous substance or article is made according to the criteria of the class or classes corresponding to those risks, as mentioned in the appropriate sub-section(s) 2.2.x.1.

2.1.2.2 All dangerous goods entries are listed in Table A of Chapter 3.2 in the numerical order of their UN Number. This table contains relevant information on the goods listed, such as name, class, packing group(s), label(s) to be affixed, packing and carriage provisions¹.

2.1.2.3 A substance may contain technical impurities (for example those deriving from the production process) or additives for stability or other purposes that do not affect their classification. However, a substance mentioned by name, i.e. listed as a single entry in Table A of Chapter 3.2, containing technical impurities or additives for stability or other purposes affecting its classification shall be considered a solution or mixture (see 2.1.3.3).

2.1.2.4 Dangerous goods which are listed or defined in sub-section 2.2.x.2 of each class are not to be accepted for carriage.

2.1.2.5 Goods not mentioned by name, i.e. goods not listed as single entries in Table A of Chapter 3.2 and not listed or defined in one of the above-mentioned sub-sections 2.2.x.2 shall be assigned to the relevant class in accordance with the procedure of section 2.1.3. In addition, the subsidiary risk (if any) and the packing group (if any) shall be determined. Once the class, subsidiary risk (if any) and packing group (if any) have been established the relevant UN number shall be determined. The decision trees in sub-sections 2.2.x.3 (list of collective entries) at the end of each class indicate the relevant parameters for selecting the relevant collective entry (UN number). In all cases the most specific collective entry covering the properties of the substance or article shall be selected, according to the hierarchy indicated in 2.1.1.2 by the letters B, C and D respectively. If the substance or article cannot be classified under entries of type B or C according to 2.1.1.2, then, and only then shall it be classified under an entry of type D.

2.1.2.6 On the basis of the test procedures of Chapter 2.3 and the criteria set out in sub-sections 2.2.x.1 of classes when it is so specified, it may be determined that a substance, solution or mixture of a certain class, mentioned by name in Table A of Chapter 3.2, does not meet the criteria of that class. In such a case, the substance, solution or mixture is deemed not to belong to that class.

¹ **Note by the Secretariat:** An alphabetic list of these entries has been prepared by the secretariat and is reproduced in Table B of Chapter 3.2. This table is not an official part of the ADR.

2.1.2.7 For the purposes of classification, substances with a melting point or initial melting point of 20 °C or lower at a pressure of 101.3 kPa shall be considered to be liquids. A viscous substance for which a specific melting point cannot be determined shall be subjected to the ASTM D 4359-90 test or to the test for determining fluidity (penetrometer test) prescribed in 2.3.4.

2.1.3 Classification of substances, including solutions and mixtures (such as preparations and wastes), not mentioned by name

2.1.3.1 Substances including solutions and mixtures not mentioned by name shall be classified according to their degree of danger on the basis of the criteria mentioned in sub-section 2.2.x.1 of the various classes. The danger(s) presented by a substance shall be determined on the basis of its physical and chemical characteristics and physiological properties. Such characteristics and properties shall also be taken into account when such experience leads to a more stringent assignment.

2.1.3.2 A substance not mentioned by name in Table A of Chapter 3.2 presenting a single hazard shall be classified in the relevant class under a collective entry listed in sub-section 2.2.x.3 of that class.

2.1.3.3 A solution or mixture composed of a single predominant substance mentioned by name in Table A of Chapter 3.2 and one or more substances not subject to ADR or traces of one or more substances mentioned by name in Table A of Chapter 3.2, shall be assigned the UN number and proper shipping name of the predominant substance mentioned by name in Table A of Chapter 3.2 unless:

- (a) The solution or mixture is mentioned by name in Table A of Chapter 3.2;
- (b) The name and description of the substance mentioned by name in Table A of Chapter 3.2 specifically indicate that they apply only to the pure substance;
- (c) The class, classification code, packing group, or physical state of the solution or mixture is different from that of the substance mentioned by name in Table A of Chapter 3.2; or
- (d) The hazard characteristics and properties of the solution or mixture necessitate emergency response measures that are different from those required for the substance mentioned by name in Table A of Chapter 3.2.

In those other cases, except the one described in (a), the solution or mixture shall be classified as a substance not mentioned by name in the relevant class under a collective entry listed in sub-section 2.2.x.3 of that class taking account of the subsidiary risks presented by that solution or mixture, if any, unless the solution or mixture does not meet the criteria of any class, in which case it is not subject to ADR.

2.1.3.4 Solutions and mixtures containing substances belonging to one of the entries mentioned in 2.1.3.4.1 or 2.1.3.4.2 shall be classified in accordance with the provisions of these paragraphs.

2.1.3.4.1 Solutions and mixtures containing one of the following substances mentioned by name shall always be classified under the same entry as the substance they contain, provided they do not have the hazard characteristics as indicated in 2.1.3.5.3:

- Class 3

UN No. 1921 PROPYLENEIMINE, STABILIZED; UN No. 3064 NITROGLYCERIN SOLUTION IN ALCOHOL with more than 1% but not more than 5% nitroglycerin;

- Class 6.1

UN No. 1051 HYDROGEN CYANIDE, STABILIZED, containing less than 3% water; UN No. 1185 ETHYLENEIMINE, STABILIZED; UN No. 1259 NICKEL CARBONYL; UN No. 1613 HYDROCYANIC ACID, AQUEOUS SOLUTION (HYDROGEN CYANIDE, AQUEOUS SOLUTION), with not more than 20% hydrogen cyanide; UN No. 1614 HYDROGEN CYANIDE, STABILIZED, containing not more than 3% water and absorbed in a porous inert material; UN No. 1994 IRON PENTACARBONYL; UN No. 2480 METHYL ISOCYANATE; UN No. 2481 ETHYL ISOCYANATE; UN No. 3294 HYDROGEN CYANIDE, SOLUTION IN ALCOHOL, with not more than 45% hydrogen cyanide;

- Class 8

UN No. 1052 HYDROGEN FLUORIDE, ANHYDROUS; UN No. 1744 BROMINE or UN No. 1744 BROMINE SOLUTION; UN No. 1790 HYDROFLUORIC ACID with more than 85% hydrogen fluoride; UN No. 2576 PHOSPHORUS OXYBROMIDE, MOLTEN;

2.1.3.4.2 Solutions and mixtures containing a substance belonging to one of the following entries of Class 9:

UN No. 2315 POLYCHLORINATED BIPHENYLS, LIQUID;
UN No. 3151 POLYHALOGENATED BIPHENYLS, LIQUID;
UN No. 3151 POLYHALOGENATED TERPHENYLS, LIQUID;
UN No. 3152 POLYHALOGENATED BIPHENYLS, SOLID;
UN No. 3152 POLYHALOGENATED TERPHENYLS, SOLID; or
UN No. 3432 POLYCHLORINATED BIPHENYLS, SOLID

shall always be classified under the same entry of Class 9 provided that:

- they do not contain any additional dangerous component other than components of packing group III of classes 3, 4.1, 4.2, 4.3, 5.1, 6.1 or 8; and
- they do not have the hazard characteristics as indicated in 2.1.3.5.3.

2.1.3.5 Substances not mentioned by name in Table A of Chapter 3.2, having more than one hazard characteristic and solutions or mixtures containing several dangerous substances shall be classified under a collective entry (see 2.1.2.5) and packing group of the appropriate class in accordance with their hazard characteristics. Such classification according to the hazard characteristics shall be carried out as follows:

2.1.3.5.1 The physical and chemical characteristics and physiological properties shall be determined by measurement or calculation and the substance, solution or mixture shall be classified according to the criteria mentioned in sub-section 2.2.x.1 of the various classes.

2.1.3.5.2 If this determination is not possible without disproportionate cost or effort (as for some kinds of wastes), the substance, solution or mixture shall be classified in the class of the component presenting the major hazard.

- 2.1.3.5.3 If the hazard characteristics of the substance, solution or mixture fall within more than one class or group of substances listed below then the substance, solution or mixture shall be classified in the class or group of substances corresponding to the major hazard on the basis of the following order of precedence:
- (a) Material of Class 7 (apart from radioactive material in excepted packages for which special provision 290 of Chapter 3.3 applies, where the other hazardous properties take precedence);
 - (b) Substances of Class 1;
 - (c) Substances of Class 2;
 - (d) Liquid desensitized explosives of Class 3;
 - (e) Self-reactive substances and solid desensitized explosives of Class 4.1;
 - (f) Pyrophoric substances of Class 4.2;
 - (g) Substances of Class 5.2;
 - (h) Substances of Class 6.1 or Class 3 which, on the basis of their inhalation toxicity, are to be classified under Packing group I (Substances meeting the classification criteria of Class 8 and having an inhalation toxicity of dust and mist (LC₅₀) in the range of Packing group I and a toxicity through oral ingestion or dermal contact only in the range of Packing group III or less, shall be allocated to Class 8);
 - (i) Infectious substances of Class 6.2.
- 2.1.3.5.4 If the hazard characteristics of the substance fall within more than one class or group of substances not listed in 2.1.3.5.3 above, the substance shall be classified in accordance with the same procedure but the relevant class shall be selected according to the precedence of hazards table in 2.1.3.10.
- 2.1.3.5.5 If the substance to be carried is a waste, with a composition that is not precisely known, its assignment to a UN number and packing group in accordance with 2.1.3.5.2 may be based on the consignor's knowledge of the waste, including all available technical and safety data as requested by safety and environmental legislation in force².

In case of doubt, the highest danger level shall be taken.

If however, on the basis of the knowledge of the composition of the waste and the physical and chemical properties of the identified components, it is possible to demonstrate that the properties of the waste do not correspond to the properties of the packing group I level, the waste may be classified by default in the most appropriate n.o.s. entry of packing group II.

This procedure may not be used for wastes containing substances mentioned in 2.1.3.5.3, substances of Class 4.3, substances of the case mentioned in 2.1.3.7 or substances which are not accepted for carriage in accordance with 2.2.x.2.

² Such legislation is for instance the Commission Decision 2000/532/EC of 3 May 2000 replacing Decision 94/3/EC establishing a list of wastes pursuant to Article 1(a) of Council Directive 75/442/EEC on waste (replaced by the Directive 2006/12/EC of the European Parliament and of the Council (Official Journal of the European Union No. L 114 of 27 April 2006, page 9)) and Council Decision 94/904/EC establishing a list of hazardous wastes pursuant to Article 1(4) of Council Directive 91/689/EEC on hazardous wastes (Official Journal of the European Communities No. L 226 of 6 September 2000, page 3).

- 2.1.3.6 The most specific applicable collective entry (see 2.1.2.5) shall always be used, i.e. a general n.o.s. entry shall only be used if a generic entry or a specific n.o.s. entry cannot be used.
- 2.1.3.7 Solutions and mixtures of oxidizing substances or substances with an oxidizing subsidiary risk may have explosive properties. In such a case they are not to be accepted for carriage unless they meet the requirements for Class 1.
- 2.1.3.8 Substances of classes 1 to 9, other than those assigned to UN Nos. 3077 or 3082, meeting the criteria of 2.2.9.1.10 are additionally to their hazards of classes 1 to 9 considered to be environmentally hazardous substances. Other substances meeting the criteria of 2.2.9.1.10 are to be assigned to UN Nos. 3077 or 3082 as appropriate.
- 2.1.3.9 Wastes that do not meet the criteria for classification in classes 1 to 9 but are covered by the *Basel Convention on the Control of Transboundary Movements of Hazardous Wastes and their Disposal* may be carried under UN Nos. 3077 or 3082.

2.1.3.10 Table of precedence of hazards

Class and packing group	4.1, II	4.1, III	4.2, II	4.2, III	4.3, I	4.3, II	4.3, III	5.1, I	5.1, II	5.1, III	6.1, I DERMAL	6.1, I ORAL	6.1, II	6.1, III	8, I	8, II	8, III	9
3, I	SOL LIQ 4.1 3, I	SOL LIQ 4.1 3, I	SOL LIQ 4.2 3, I	SOL LIQ 4.2 3, I	4.3, I	4.3, I	4.3, I	SOL LIQ 5.1, I 3, I	SOL LIQ 5.1, I 3, I	SOL LIQ 5.1, I 3, I	3, I	3, I	3, I	3, I	3, I	3, I	3, I	3, I
3, II	SOL LIQ 4.1 3, II	SOL LIQ 4.1 3, II	SOL LIQ 4.2 3, II	SOL LIQ 4.2 3, II	4.3, I	4.3, II	4.3, II	SOL LIQ 5.1, I 3, I	SOL LIQ 5.1, II 3, II	SOL LIQ 5.1, II 3, II	3, I	3, I	3, II	3, II	8, I	3, II	3, II	3, II
3, III	SOL LIQ 4.1 3, III	SOL LIQ 4.1 3, III	SOL LIQ 4.2 3, III	SOL LIQ 4.2 3, III	4.3, I	4.3, II	4.3, III	SOL LIQ 5.1, I 3, I	SOL LIQ 5.1, II 3, II	SOL LIQ 5.1, III 3, III	6.1, I	6.1, I	6.1, II	3, III ^a	8, I	8, II	3, III	3, III
4.1, II			4.2, II	4.2, II	4.3, I	4.3, II	4.3, II	5.1, I	4.1, II	4.1, II	6.1, I	6.1, I	SOL LIQ 4.1, II 6.1, II	SOL LIQ 4.1, II 6.1, II	8, I	SOL LIQ 4.1, II 8, II	SOL LIQ 4.1, II 8, II	4.1, II
4.1, III			4.2, II	4.2, III	4.3, I	4.3, II	4.3, III	5.1, I	4.1, II	4.1, III	6.1, I	6.1, I	6.1, II	SOL LIQ 4.1, III 6.1, III	8, I	8, II	SOL LIQ 4.1, III 8, III	4.1, III
4.2, II					4.3, I	4.3, II	4.3, II	5.1, I	4.2, II	4.2, II	6.1, I	6.1, I	4.2, II	4.2, II	8, I	4.2, II	4.2, II	4.2, II
4.2, III					4.3, I	4.3, II	4.3, III	5.1, I	5.1, II	4.2, III	6.1, I	6.1, I	6.1, II	4.2, III	8, I	8, II	4.2, III	4.2, III
4.3, I								5.1, I	4.3, I	4.3, I	6.1, I	4.3, I	4.3, I	4.3, I	4.3, I	4.3, I	4.3, I	4.3, I
4.3, II								5.1, I	4.3, II	4.3, II	6.1, I	4.3, I	4.3, II	4.3, II	8, I	4.3, II	4.3, II	4.3, II
4.3, III								5.1, I	5.1, II	4.3, III	6.1, I	6.1, I	6.1, II	4.3, III	8, I	8, II	4.3, III	4.3, III
5.1, I											5.1, I	5.1, I	5.1, I	5.1, I	5.1, I	5.1, I	5.1, I	5.1, I
5.1, II											6.1, I	5.1, I	5.1, II	5.1, II	8, I	5.1, II	5.1, II	5.1, II
5.1, III											6.1, I	6.1, I	6.1, II	5.1, III	8, I	8, II	5.1, III	5.1, III
6.1, I DERMAL															SOL LIQ 6.1, I 8, I	6.1, I	6.1, I	6.1, I
6.1, I ORAL															SOL LIQ 6.1, I 8, I	6.1, I	6.1, I	6.1, I
6.1, II INHAL															SOL LIQ 6.1, I 8, I	6.1, II	6.1, II	6.1, II
6.1, II DERMAL															SOL LIQ 6.1, I 8, I	SOL LIQ 6.1, II 8, II	6.1, II	6.1, II
6.1, II ORAL															8, I	SOL LIQ 6.1, II 8, II	6.1, II	6.1, II
6.1, III															8, I	8, II	8, III	6.1, III
8, I																		8, I
8, II																		8, II
8, III																		8, III

SOL = Solid substances and mixtures
 LIQ = Liquid substances, mixtures and solutions
 DERMAL = Dermal toxicity
 ORAL = Oral toxicity
 INHAL = Inhalation toxicity

^a Class 6.1 for pesticides

NOTE 1: *Examples to explain the use of the table*

Classification of a single substance

Description of the substance to be classified:

An amine not mentioned by name meeting the criteria for Class 3, packing group II as well as those for Class 8, packing group I.

Procedure:

The intersection of line 3 II with column 8 I gives 8 I.

This amine has therefore to be classified in Class 8 under:

UN No. 2734 AMINES LIQUID, CORROSIVE, FLAMMABLE, N.O.S. or UN No. 2734 POLYAMINES, LIQUID, CORROSIVE, FLAMMABLE, N.O.S. packing group I

Classification of a mixture

Description of the mixture to be classified:

Mixture consisting of a flammable liquid classified in Class 3, packing group III, a toxic substance in Class 6.1, packing group II and a corrosive substance in Class 8, packing group I.

Procedure:

The intersection of line 3 III with column 6.1 II gives 6.1 II.

The intersection of line 6.1 II with column 8 I gives 8 I LIQ.

This mixture not further defined has therefore to be classified in Class 8 under:

UN No. 2922 CORROSIVE LIQUID, TOXIC, N.O.S. packing group I.

NOTE 2: *Examples for the classification of mixtures and solutions under a class and a packing group:*

A phenol solution of Class 6.1, (II), in benzene of Class 3, (II) is to be classified in Class 3, (II); this solution is to be classified under UN No. 1992 FLAMMABLE LIQUID, TOXIC, N.O.S., Class 3, (II), by virtue of the toxicity of the phenol.

A solid mixture of sodium arsenate of Class 6.1, (II) and sodium hydroxide of Class 8, (II) is to be classified under UN No. 3290 TOXIC SOLID, CORROSIVE, INORGANIC, N.O.S., in Class 6.1 (II).

A solution of crude or refined naphthalene of Class 4.1, (III) in petrol of Class 3, (II), is to be classified under UN No. 3295 HYDROCARBONS, LIQUID, N.O.S. in Class 3, (II).

A mixture of hydrocarbons of Class 3, (III), and of polychlorinated biphenyls (PCB) of Class 9, (II), is to be classified under UN No. 2315 POLYCHLORINATED BIPHENYLS LIQUID or UN No. 3432 POLYCHLORINATED BIPHENYLS SOLID in Class 9, (II).

A mixture of propyleneimine of Class 3, and polychlorinated biphenyls (PCB) of Class 9, (II), is to be classified under UN No. 1921 PROPYLENEIMINE, INHIBITED in Class 3.

2.1.4 Classification of samples

2.1.4.1 When the class of a substance is uncertain and it is being carried for further testing, a tentative class, proper shipping name and UN number shall be assigned on the basis of the consignor's knowledge of the substance and application of:

- (a) the classification criteria of Chapter 2.2; and
- (b) the requirements of this Chapter.

The most severe packing group possible for the proper shipping name chosen shall be used.

Where this provision is used the proper shipping name shall be supplemented with the word "SAMPLE" (e.g., "FLAMMABLE LIQUID, N.O.S., SAMPLE"). In certain instances, where a specific proper shipping name is provided for a sample of a substance considered to meet certain classification criteria (e.g., GAS SAMPLE, NON-PRESSURIZED, FLAMMABLE, UN No. 3167) that proper shipping name shall be used. When an N.O.S. entry is used to carry the sample, the proper shipping name need not be supplemented with the technical name as required by special provision 274 of Chapter 3.3.

2.1.4.2 Samples of the substance shall be carried in accordance with the requirements applicable to the tentative assigned proper shipping name provided:

- (a) The substance is not considered to be a substance not accepted for carriage by sub-sections 2.2.x.2 of Chapter 2.2 or by Chapter 3.2;
- (b) The substance is not considered to meet the criteria for Class 1 or considered to be an infectious substance or a radioactive material;
- (c) The substance is in compliance with 2.2.41.1.15 or 2.2.52.1.9 if it is a self-reactive substance or an organic peroxide, respectively;
- (d) The sample is carried in a combination packaging with a net mass per package not exceeding 2.5 kg; and
- (e) The sample is not packed together with other goods.

CHAPTER 2.2

CLASS SPECIFIC PROVISIONS

2.2.1 Class 1 Explosive substances and articles

2.2.1.1 *Criteria*

2.2.1.1.1 The heading of Class 1 covers:

- (a) Explosive substances: solid or liquid substances (or mixtures of substances) capable by chemical reaction of producing gases at such a temperature and pressure and at such a speed as to cause damage to the surroundings.

Pyrotechnic substances: substances or mixtures of substances designed to produce an effect by heat, light, sound, gas or smoke or a combination of these as the result of non-detonating self-sustaining exothermic chemical reactions;

NOTE 1: Substances which are not themselves explosive but which may form an explosive mixture of gas, vapour or dust are not substances of Class 1.

NOTE 2: Also excluded from Class 1 are: water- or alcohol-wetted explosives of which the water or alcohol content exceeds the limits specified and those containing plasticizers - these explosives are assigned to Class 3 or Class 4.1 - and those explosives which, on the basis of their predominant hazard, are assigned to Class 5.2.

- (b) Explosive articles: articles containing one or more explosive or pyrotechnic substances;

NOTE: Devices containing explosive or pyrotechnic substances in such small quantity or of such a character that their inadvertent or accidental ignition or initiation during carriage would not cause any manifestation external to the device by projection, fire, smoke, heat or loud noise are not subject to the requirements of Class 1.

- (c) Substances and articles not mentioned above which are manufactured with a view to producing a practical effect by explosion or a pyrotechnic effect.

For the purposes of Class 1, the following definition applies:

Phlegmatized means that a substance (or "phlegmatizer") has been added to an explosive to enhance its safety in handling and carriage. The phlegmatizer renders the explosive insensitive, or less sensitive, to the following actions: heat, shock, impact, percussion or friction. Typical phlegmatizing agents include, but are not limited to: wax, paper, water, polymers (such as chlorofluoropolymers), alcohol and oils (such as petroleum jelly and paraffin).

2.2.1.1.2 Any substance or article having or suspected of having explosive properties shall be considered for assignment to Class 1 in accordance with the tests, procedures and criteria prescribed in Part I, Manual of Tests and Criteria.

A substance or article assigned to Class 1 can only be accepted for carriage when it has been assigned to a name or n.o.s. entry listed in Table A of Chapter 3.2 and meets the criteria of the Manual of Tests and Criteria.

2.2.1.1.3 The substances and articles of Class 1 shall be assigned to a UN Number and a name or n.o.s. entry listed in Table A of Chapter 3.2. Interpretation of the names of substances and articles in Table A of Chapter 3.2 shall be based upon the glossary in 2.2.1.1.8.

Samples of new or existing explosive substances or articles carried for purposes including: testing, classification, research and development quality control, or as a commercial sample, other than initiating explosive, may be assigned to UN No. 0190 SAMPLES, EXPLOSIVE.

The assignment of explosive substances and articles not mentioned by name as such in Table A of Chapter 3.2 to an n.o.s entry of Class 1 or UN No. 0190 SAMPLES, EXPLOSIVE as well as the assignment of certain substances the carriage of which is subject to a specific authorization by the competent authority according to the special provisions referred to in Column (6) of Table A of Chapter 3.2 shall be made by the competent authority of the country of origin. This competent authority shall also approve in writing the conditions of carriage of these substances and articles. If the country of origin is not a Contracting Party to ADR, the classification and the conditions of carriage shall be recognized by the competent authority of the first country Contracting Party to ADR reached by the consignment.

2.2.1.1.4 Substances and articles of Class 1 shall have been assigned to a division in accordance with 2.2.1.1.5 and to a compatibility group in accordance with 2.2.1.1.6. The division shall be based on the results of the tests described in 2.3.0 and 2.3.1 applying the definitions in 2.2.1.1.5. The compatibility group shall be determined in accordance with the definitions in 2.2.1.1.6. The classification code shall consist of the division number and the compatibility group letter.

2.2.1.1.5 *Definition of divisions*

Division 1.1 Substances and articles which have a mass explosion hazard (a mass explosion is an explosion which affects almost the entire load virtually instantaneously).

Division 1.2 Substances and articles which have a projection hazard but not a mass explosion hazard.

Division 1.3 Substances and articles which have a fire hazard and either a minor blast hazard or a minor projection hazard or both, but not a mass explosion hazard:

- (a) combustion of which gives rise to considerable radiant heat; or
- (b) which burn one after another, producing minor blast or projection effects or both.

Division 1.4 Substances and articles which present only a slight risk of explosion in the event of ignition or initiation during carriage. The effects are largely confined to the package and no projection of fragments of appreciable size or range is to be expected. An external fire shall not cause virtually instantaneous explosion of almost the entire contents of the package.

Division 1.5 Very insensitive substances having a mass explosion hazard which are so insensitive that there is very little probability of initiation or of transition from burning to detonation under normal conditions of carriage. As a minimum requirement they must not explode in the external fire test.

Division 1.6 Extremely insensitive articles which do not have a mass explosion hazard. The articles contain only extremely insensitive detonating substances and demonstrate a negligible probability of accidental initiation or propagation.

***NOTE:** The risk from articles of Division 1.6 is limited to the explosion of a single article.*

2.2.1.1.6 *Definition of compatibility groups of substances and articles*

- A Primary explosive substance.
- B Article containing a primary explosive substance and not having two or more effective protective features. Some articles, such as detonators for blasting, detonator assemblies for blasting and primers, cap-type, are included, even though they do not contain primary explosives.
- C Propellant explosive substance or other deflagrating explosive substance or article containing such explosive substance.
- D Secondary detonating explosive substance or black powder or article containing a secondary detonating explosive substance, in each case without means of initiation and without a propelling charge, or article containing a primary explosive substance and having two or more effective protective features.
- E Article containing a secondary detonating explosive substance, without means of initiation, with a propelling charge (other than one containing a flammable liquid or gel or hypergolic liquids).
- F Article containing a secondary detonating explosive substance with its own means of initiation, with a propelling charge (other than one containing a flammable liquid or gel or hypergolic liquids) or without a propelling charge.
- G Pyrotechnic substance, or article containing a pyrotechnic substance, or article containing both an explosive substance and an illuminating, incendiary, tear- or smoke-producing substance (other than a water-activated article or one which contains white phosphorus, phosphides, a pyrophoric substance, a flammable liquid or gel or hypergolic liquids).
- H Article containing both an explosive substance and white phosphorus.
- J Article containing both an explosive substance and a flammable liquid or gel.
- K Article containing both an explosive substance and a toxic chemical agent.
- L Explosive substance or article containing an explosive substance and presenting a special risk (e.g. due to water activation or the presence of hypergolic liquids, phosphides or a pyrophoric substance) necessitating isolation of each type.
- N Articles containing only extremely insensitive detonating substances.
- S Substance or article so packed or designed that any hazardous effects arising from accidental functioning are confined within the package unless the package has been degraded by fire, in which case all blast or projection effects are limited to the extent that they do not significantly hinder or prevent fire-fighting or other emergency response efforts in the immediate vicinity of the package.

NOTE 1: *Each substance or article, packed in a specified packaging, may be assigned to one compatibility group only. Since the criterion of compatibility group S is empirical, assignment to this group is necessarily linked to the tests for assignment of a classification code.*

NOTE 2: *Articles of compatibility groups D and E may be fitted or packed together with their own means of initiation provided that such means have at least two effective protective features designed to prevent an explosion in the event of accidental functioning of the means of initiation. Such articles and packages shall be assigned to compatibility groups D or E.*

NOTE 3: *Articles of compatibility groups D and E may be packed together with their own means of initiation, which do not have two effective protective features (i.e. means of initiation assigned to compatibility group B), provided that they comply with mixed packing provision MP21 of Section 4.1.10. Such packages shall be assigned to compatibility groups D or E.*

NOTE 4: *Articles may be fitted or packed together with their own means of ignition provided that the means of ignition cannot function during normal conditions of carriage.*

NOTE 5: *Articles of compatibility groups C, D and E may be packed together. Such packages shall be assigned to compatibility group E.*

2.2.1.1.7 *Assignment of fireworks to divisions*

2.2.1.1.7.1 Fireworks shall normally be assigned to divisions 1.1, 1.2, 1.3, and 1.4 on the basis of test data derived from Test Series 6 of the Manual of Tests and Criteria. However, since the range of such articles is very extensive and the availability of test facilities may be limited, assignment to divisions may also be made in accordance with the procedure in 2.2.1.1.7.2.

2.2.1.1.7.2 Assignment of fireworks to UN Nos. 0333, 0334, 0335 and 0336 may be made on the basis of analogy, without the need for Test Series 6 testing, in accordance with the default fireworks classification table in 2.2.1.1.7.5. Such assignment shall be made with the agreement of the competent authority. Items not specified in the table shall be classified on the basis of test data derived from Test Series 6.

NOTE 1: *The addition of other types of fireworks to column 1 of the table in 2.2.1.1.7.5 shall only be made on the basis of full test data submitted to the UN Sub-Committee of Experts on the Transport of Dangerous Goods for consideration.*

NOTE 2: *Test data derived by competent authorities which validates, or contradicts the assignment of fireworks specified in column 4 of the table in 2.2.1.1.7.5 to divisions in column 5 should be submitted to the UN Sub-Committee of Experts on the Transport of Dangerous Goods for information.*

2.2.1.1.7.3 Where fireworks of more than one division are packed in the same package, they shall be classified on the basis of the most dangerous division unless test data derived from Test Series 6 indicate otherwise.

2.2.1.1.7.4 The classification shown in the table in 2.2.1.1.7.5 applies only for articles packed in fibreboard boxes (4G).

2.2.1.1.7.5 Default fireworks classification table¹

NOTE 1: *References to percentages in the table, unless otherwise stated, are to the mass of all pyrotechnic substances (e.g. rocket motors, lifting charge, bursting charge and effect charge).*

NOTE 2: *"Flash composition" in this table refers to pyrotechnic substances in powder form or as pyrotechnic units as presented in the fireworks, that are used to produce an aural effect, or used as a bursting charge or lifting charge, unless the time taken for the pressure rise is demonstrated to be more than 8 ms for 0.5 g of pyrotechnic substance in the HSL Flash Composition Test in Appendix 7 of the Manual of Tests and Criteria.*

NOTE 3: *Dimensions in mm refer to:*

- *for spherical and peanut shells the diameter of the sphere of the shell;*
- *for cylinder shells the length of the shell;*
- *for a shell in mortar, Roman candle, shot tube firework or mine the inside diameter of the tube comprising or containing the firework;*
- *for a bag mine or cylinder mine, the inside diameter of the mortar intended to contain the mine.*

¹ This table contains a list of firework classifications which may be used in the absence of Test Series 6 data (see 2.2.1.1.7.2).

Type	Includes: / Synonym:	Definition	Specification	Classification	
Shell, spherical or cylindrical	Spherical display shell: aerial shell, colour shell, dye shell, multi-break shell, multi-effect shell, nautical shell, parachute shell, smoke shell, star shell; report shell: maroon, salute, sound shell, thunderclap, aerial shell kit	Device with or without propellant charge, with delay fuse and bursting charge, pyrotechnic unit(s) or loose pyrotechnic substance and designed to be projected from a mortar	All report shells	1.1G	
			Colour shell: ≥ 180 mm	1.1G	
			Colour shell: < 180 mm with $> 25\%$ flash composition, as loose powder and/or report effects	1.1G	
			Colour shell: < 180 mm with $\leq 25\%$ flash composition, as loose powder and/or report effects	1.3G	
			Colour shell: ≤ 50 mm, or ≤ 60 g pyrotechnic substance, with $\leq 2\%$ flash composition as loose powder and/or report effects	1.4G	
	Peanut shell	Device with two or more spherical aerial shells in a common wrapper propelled by the same propellant charge with separate external delay fuses	The most hazardous spherical aerial shell determines the classification		
	Preloaded mortar, shell in mortar	Assembly comprising a spherical or cylindrical shell inside a mortar from which the shell is designed to be projected	All report shells	1.1G	
			Colour shell: ≥ 180 mm	1.1G	
			Colour shell: $> 25\%$ flash composition as loose powder and/or report effects	1.1G	
			Colour shell: > 50 mm and < 180 mm	1.2G	
			Colour shell: ≤ 50 mm, or ≤ 60 g pyrotechnic substance, with $\leq 25\%$ flash composition as loose powder and/or report effects	1.3G	

Type	Includes: / Synonym:	Definition	Specification	Classification
Shell, spherical or cylindrical <i>(cont'd)</i>	Shell of shells (spherical) <i>(Reference to percentages for shell of shells are to the gross mass of the fireworks article)</i>	Device without propellant charge, with delay fuse and bursting charge, containing report shells and inert materials and designed to be projected from a mortar	> 120 mm	1.1G
		Device without propellant charge, with delay fuse and bursting charge, containing report shells ≤ 25g flash composition per report unit, with ≤ 33% flash composition and ≥ 60% inert materials and designed to be projected from a mortar	≤ 120 mm	1.3G
		Device without propellant charge, with delay fuse and bursting charge, containing colour shells and/or pyrotechnic units and designed to be projected from a mortar	> 300 mm	1.1G
		Device without propellant charge, with delay fuse and bursting charge, containing colour shells ≤ 70mm and/or pyrotechnic units, with ≤ 25% flash composition and ≤ 60% pyrotechnic substance and designed to be projected from a mortar	> 200 mm and ≤ 300 mm	1.3G
		Device with propellant charge, with delay fuse and bursting charge, containing colour shells ≤ 70 mm and/or pyrotechnic units, with ≤ 25% flash composition and ≤ 60% pyrotechnic substance and designed to be projected from a mortar	≤ 200 mm	1.3G
Battery/ combination	Barrage, bombardos, cakes, finale box, flowerbed, hybrid, multiple tubes, shell cakes, banger batteries, flash banger batteries	Assembly including several elements either containing the same type or several types each corresponding to one of the types of fireworks listed in this table, with one or two points of ignition	The most hazardous firework type determines the classification	

Type	Includes: / Synonym:	Definition	Specification	Classification
Roman candle	Exhibition candle, candle, bombettes	Tube containing a series of pyrotechnic units consisting of alternate pyrotechnic substance, propellant charge, and transmitting fuse	≥ 50 mm inner diameter, containing flash composition, or < 50 mm with $> 25\%$ flash composition	1.1G
			≥ 50 mm inner diameter, containing no flash composition	1.2G
			< 50 mm inner diameter and $\leq 25\%$ flash composition	1.3G
			≤ 30 mm inner diameter, each pyrotechnic unit ≤ 25 g and $\leq 5\%$ flash composition	1.4G
Shot tube	Single shot Roman candle, small preloaded mortar	Tube containing a pyrotechnic unit consisting of pyrotechnic substance, propellant charge with or without transmitting fuse	≤ 30 mm inner diameter and pyrotechnic unit > 25 g, or $> 5\%$ and $\leq 25\%$ flash composition	1.3G
			≤ 30 mm inner diameter, pyrotechnic unit ≤ 25 g and $\leq 5\%$ flash composition	1.4G
Rocket	Avalanche rocket, signal rocket, whistling rocket, bottle rocket, sky rocket, missile type rocket, table rocket	Tube containing pyrotechnic substance and/or pyrotechnic units, equipped with stick(s) or other means for stabilization of flight, and designed to be propelled into the air	Flash composition effects only	1.1G
			Flash composition $> 25\%$ of the pyrotechnic substance	1.1G
			> 20 g pyrotechnic substance and flash composition $\leq 25\%$	1.3G
			≤ 20 g pyrotechnic substance, black powder bursting charge and ≤ 0.13 g flash composition per report and ≤ 1 g in total	1.4G

Type	Includes: / Synonym:	Definition	Specification	Classification
Mine	Pot-a-feu, ground mine, bag mine, cylinder mine	Tube containing propellant charge and pyrotechnic units and designed to be placed on the ground or to be fixed in the ground. The principal effect is ejection of all the pyrotechnic units in a single burst producing a widely dispersed visual and/or aural effect in the air or: Cloth or paper bag or cloth or paper cylinder containing propellant charge and pyrotechnic units, designed to be placed in a mortar and to function as a mine	> 25% flash composition, as loose powder and/ or report effects	1.1G
			≥ 180 mm and ≤ 25% flash composition, as loose powder and/ or report effects	1.1G
			< 180 mm and ≤ 25% flash composition, as loose powder and/ or report effects	1.3G
			≤ 150 g pyrotechnic substance, containing ≤ 5% flash composition as loose powder and/ or report effects. Each pyrotechnic unit ≤ 25 g, each report effect < 2g; each whistle, if any, ≤ 3 g	1.4G
Fountain	Volcanos, gerbs, showers, lances, Bengal fire, flitter sparkle, cylindrical fountains, cone fountains, illuminating torch	Non-metallic case containing pressed or consolidated pyrotechnic substance producing sparks and flame	≥ 1 kg pyrotechnic substance	1.3G
			< 1 kg pyrotechnic substance	1.4G
Sparkler	Handheld sparklers, non-handheld sparklers, wire sparklers	Rigid wire partially coated (along one end) with slow burning pyrotechnic substance with or without an ignition tip	Perchlorate based sparklers: > 5 g per item or > 10 items per pack	1.3G
			Perchlorate based sparklers: ≤ 5 g per item and ≤ 10 items per pack; Nitrate based sparklers: ≤ 30 g per item	1.4G

Type	Includes: / Synonym:	Definition	Specification	Classification
Bengal stick	Dipped stick	Non-metallic stick partially coated (along one end) with slow-burning pyrotechnic substance and designed to be held in the hand	Perchlorate based items: > 5 g per item or > 10 items per pack	1.3 G
			Perchlorate based items: ≤ 5 g per item and ≤ 10 items per pack; nitrate based items: ≤ 30 g per item	1.4G
Low hazard fireworks and novelties	Table bombs, throwdowns, crackling granules, smokes, fog, snakes, glow worm, serpents, snaps, party poppers	Device designed to produce very limited visible and/ or audible effect which contains small amounts of pyrotechnic and/or explosive composition.	Throwdowns and snaps may contain up to 1.6 mg of silver fulminate; snaps and party poppers may contain up to 16 mg of potassium chlorate/red phosphorous mixture; other articles may contain up to 5 g of pyrotechnic substance, but no flash composition	1.4G
Spinner	Aerial spinner, helicopter, chaser, ground spinner	Non-metallic tube or tubes containing gas- or spark-producing pyrotechnic substance, with or without noise producing composition, with or without aerofoils attached	Pyrotechnic substance per item > 20 g, containing ≤ 3% flash composition as report effects, or whistle composition ≤ 5 g	1.3G
			Pyrotechnic substance per item ≤ 20 g, containing ≤ 3% flash composition as report effects, or whistle composition ≤ 5 g	1.4G
Wheels	Catherine wheels, Saxon	Assembly including drivers containing pyrotechnic substance and provided with a means of attaching it to a support so that it can rotate	≥ 1 kg total pyrotechnic substance, no report effect, each whistle (if any) ≤ 25 g and ≤ 50 g whistle composition per wheel	1.3G
			< 1 kg total pyrotechnic substance, no report effect, each whistle (if any) ≤ 5 g and ≤ 10 g whistle composition per wheel	1.4G

Type	Includes: / Synonym:	Definition	Specification	Classification
Aerial wheel	Flying Saxon, UFO's, rising crown	Tubes containing propellant charges and sparks-flame- and/or noise producing pyrotechnic substances, the tubes being fixed to a supporting ring	> 200 g total pyrotechnic substance or > 60 g pyrotechnic substance per driver, ≤ 3% flash composition as report effects, each whistle (if any) ≤ 25 g and ≤ 50 g whistle composition per wheel	1.3G
			≤ 200 g total pyrotechnic substance and ≤ 60 g pyrotechnic substance per driver, ≤ 3% flash composition as report effects, each whistle (if any) ≤ 5 g and ≤ 10 g whistle composition per wheel	1.4G
Selection pack	Display selection box, display selection pack, garden selection box, indoor selection box; assortment	A pack of more than one type each corresponding to one of the types of fireworks listed in this table	The most hazardous firework type determines the classification	
Firecracker	Celebration cracker, celebration roll, string cracker	Assembly of tubes (paper or cardboard) linked by a pyrotechnic fuse, each tube intended to produce an aural effect	Each tube ≤ 140 mg of flash composition or ≤ 1 g black powder	1.4G
Banger	Salute, flash banger, lady cracker	Non-metallic tube containing report composition intended to produce an aural effect	> 2 g flash composition per item	1.1G
			≤ 2 g flash composition per item and ≤ 10 g per inner packaging	1.3G
			≤ 1 g flash composition per item and ≤ 10 g per inner packaging or ≤ 10 g black powder per item	1.4G

2.2.1.1.8

Glossary of names

NOTE 1: *The descriptions in the glossary are not intended to replace the test procedures, nor to determine the hazard classification of a substance or article of Class 1. Assignment to the correct division and a decision on whether Compatibility Group S is appropriate shall be based on testing of the product in accordance with the Manual of Tests and Criteria, Part I or by analogy with similar products which have already been tested and assigned in accordance with the procedures of the Manual of Tests and Criteria.*

NOTE 2: *The figures given after the names refer to the relevant UN numbers (Column 1 of Table A of Chapter 3.2). For the classification code, see 2.2.1.1.4.*

AIR BAG INFLATORS or AIR BAG MODULES or SEAT-BELT PRETENSIONERS:
UN No. 0503

Articles which contain pyrotechnic substances and are used as life-saving vehicle airbags or seat-belts.

AMMUNITION, ILLUMINATING, with or without burster, expelling charge or propelling charge: UN Nos. 0171, 0254, 0297

Ammunition designed to produce a single source of intense light for lighting up an area. The term includes illuminating cartridges, grenades and projectiles; and illuminating and target identification bombs.

NOTE: *The following articles: CARTRIDGES, SIGNAL; SIGNAL DEVICES HAND; SIGNALS, DISTRESS; FLARES, AERIAL; FLARES, SURFACE are not included in this definition. They are listed separately.*

AMMUNITION, INCENDIARY, liquid or gel, with burster, expelling charge or propelling charge: UN No. 0247

Ammunition containing liquid or gelatinous incendiary substance. Except when the incendiary substance is an explosive per se, it also contains one or more of the following: a propelling charge with primer and igniter charge; a fuze with burster or expelling charge.

AMMUNITION, INCENDIARY, WHITE PHOSPHORUS with burster, expelling charge or propelling charge: UN Nos. 0243, 0244

Ammunition containing white phosphorus as incendiary substance. It also contains one or more of the following: a propelling charge with primer and igniter charge; a fuze with burster or expelling charge.

AMMUNITION, INCENDIARY with or without burster, expelling charge or propelling charge: UN Nos. 0009, 0010, 0300

Ammunition containing incendiary composition. Except when the composition is an explosive per se, it also contains one or more of the following: a propelling charge with primer and igniter charge; a fuze with burster or expelling charge.

AMMUNITION, PRACTICE: UN Nos. 0362, 0488

Ammunition without a main bursting charge, containing a burster or expelling charge. Normally it also contains a fuze and a propelling charge.

NOTE: *GRENADES, PRACTICE are not included in this definition. They are listed separately.*

AMMUNITION, PROOF: UN No. 0363

Ammunition containing pyrotechnic substances, used to test the performance or strength of new ammunition, weapon components or assemblies.

AMMUNITION, SMOKE, WHITE PHOSPHORUS, with burster, expelling charge or propelling charge: UN Nos. 0245, 0246

Ammunition containing white phosphorus as a smoke-producing substance. It also contains one or more of the following: a propelling charge with primer and igniter charge; a fuze with burster or expelling charge. The term includes grenades, smoke.

AMMUNITION, SMOKE with or without burster, expelling charge or propelling charge: UN Nos. 0015, 0016, 0303

Ammunition containing a smoke-producing substance such as chlorosulphonic acid mixture or titanium tetrachloride; or a smoke-producing pyrotechnic composition based on hexachloroethane or red phosphorus. Except when the substance is an explosive *per se*, the ammunition also contains one or more of the following: a propelling charge with primer and igniter charge; a fuze with burster or expelling charge. The term includes grenades, smoke.

NOTE: SIGNALS, SMOKE are not included in this definition. They are listed separately.

AMMUNITION, TEAR-PRODUCING, with burster, expelling charge or propelling charge: UN Nos. 0018, 0019, 0301

Ammunition containing a tear-producing substance. It also contains one or more of the following: a pyrotechnic substance; a propelling charge with primer and igniter charge; a fuze with burster or expelling charge.

ARTICLES, EXPLOSIVE, EXTREMELY INSENSITIVE (ARTICLES EEI): UN No. 0486

Articles containing only extremely insensitive detonating substances (EIDS) which demonstrate a negligible probability of accidental initiation or propagation under normal conditions of transport, and which have passed Test Series 7.

ARTICLES, PYROPHORIC: UN No. 0380

Articles which contain a pyrophoric substance (capable of spontaneous ignition when exposed to air) and an explosive substance or component. The term excludes articles containing white phosphorus.

ARTICLES, PYROTECHNIC, for technical purposes: UN Nos. 0428, 0429, 0430, 0431, 0432

Articles which contain pyrotechnic substances and are used for technical purposes such as heat generation, gas generation, theatrical effects, etc.

NOTE: The following articles: all ammunition; CARTRIDGES, SIGNAL; CUTTERS, CABLE, EXPLOSIVE; FIREWORKS; FLARES, AERIAL; FLARES, SURFACE; RELEASE DEVICES, EXPLOSIVE; RIVETS, EXPLOSIVE; SIGNAL DEVICES, HAND; SIGNALS, DISTRESS; SIGNALS, RAILWAY TRACK, EXPLOSIVES; SIGNALS, SMOKE are not included in this definition. They are listed separately.

BLACK POWDER (GUNPOWDER), COMPRESSED or BLACK POWDER (GUNPOWDER), IN PELLETS: UN No. 0028

Substance consisting of a pelletized form of black powder.

BLACK POWDER (GUNPOWDER), granular or as meal: UN No. 0027

Substance consisting of an intimate mixture of charcoal or other carbon and either potassium nitrate or sodium nitrate, with or without sulphur.

BOMBS, WITH FLAMMABLE LIQUID, with bursting charge: UN Nos. 0399, 0400

Articles which are dropped from aircraft, consisting of a tank filled with inflammable liquid and bursting charge.

BOMBS, PHOTO-FLASH: UN No. 0038

Explosive articles which are dropped from aircraft to provide brief, intense illumination for photography. They contain a charge of detonating explosive without means of initiation or with means of initiation containing two or more effective protective features.

BOMBS, PHOTO-FLASH: UN No. 0037

Explosive articles which are dropped from aircraft to provide brief, intense illumination for photography. They contain a charge of detonating explosive with means of initiation not containing two or more effective protective features.

BOMBS, PHOTO-FLASH: UN Nos. 0039, 0299

Explosive articles which are dropped from aircraft to provide brief, intense illumination for photography. They contain a photo-flash composition.

BOMBS with bursting charge: UN Nos. 0034; 0035

Explosive articles which are dropped from aircraft, without means of initiation or with means of initiation containing two or more effective protective features.

BOMBS with bursting charge: UN Nos. 0033, 0291

Explosive articles which are dropped from aircraft, with means of initiation not containing two or more effective protective features.

BOOSTERS WITH DETONATOR: UN Nos. 0225, 0268

Articles consisting of a charge of detonating explosive with means of initiation. They are used to increase the initiating power of detonators or detonating cord.

BOOSTERS without detonator: UN Nos. 0042, 0283

Articles consisting of a charge of detonating explosive without means of initiation. They are used to increase the initiating power of detonators or detonating cord.

BURSTERS, explosive: UN No. 0043

Articles consisting of a small charge of explosive used to open projectiles or other ammunition in order to disperse their contents.

CARTRIDGES, FLASH: UN Nos. 0049, 0050

Articles consisting of a casing, a primer and flash powder, all assembled in one piece ready for firing.

CARTRIDGES FOR WEAPONS, BLANK: UN Nos. 0326, 0413, 0327, 0338, 0014

Ammunition consisting of a closed cartridge case with a centre or rim fire primer and a charge of smokeless or black powder but no projectile. It produces a loud noise and is used for training, saluting, propelling charge, starter pistols, etc. The term includes ammunition, blank.

CARTRIDGES FOR WEAPONS, INERT PROJECTILE: UN Nos. 0328, 0417, 0339, 0012

Ammunition consisting of a projectile without bursting charge but with a propelling charge with or without a primer. The articles may include a tracer, provided that the predominant hazard is that of the propelling charge.

CARTRIDGES FOR WEAPONS with bursting charge: UN Nos. 0006, 0321, 0412

Ammunition consisting of a projectile with a bursting charge without means of initiation or with means of initiation containing two or more effective protective features; and a propelling charge with or without a primer. The term includes fixed (assembled) ammunition, semi-fixed (partially assembled) ammunition and separate loading ammunition when the components are packed together.

CARTRIDGES FOR WEAPONS with bursting charge: UN Nos. 0005, 0007, 0348

Ammunition consisting of a projectile with a bursting charge with means of initiation not containing two or more effective protective features; and a propelling charge with or without a primer. The term includes fixed (assembled) ammunition, semi-fixed (partially assembled) ammunition and separate loading ammunition when the components are packed together.

CARTRIDGES, OIL WELL: UN Nos. 0277, 0278

Articles consisting of a thin casing of fibreboard, metal or other material containing only propellant powder which projects a hardened projectile to perforate an oil well casing.

NOTE: *CHARGES, SHAPED are not included in this definition. They are listed separately.*

CARTRIDGES, POWER DEVICE: UN Nos. 0275, 0276, 0323, 0381

Articles designed to accomplish mechanical actions. They consist of a casing with a charge of deflagrating explosive and a means of ignition. The gaseous products of the deflagration produce inflation, linear or rotary motion or activate diaphragms, valves or switches or project fastening devices or extinguishing agents.

CARTRIDGES, SIGNAL: UN Nos. 0054, 0312, 0405

Articles designed to fire coloured flares or other signals from signal pistols, etc.

CARTRIDGES, SMALL ARMS: UN Nos. 0417, 0339, 0012

Ammunition consisting of a cartridge case fitted with a centre or rim fire primer and containing both a propelling charge and solid projectile. They are designed to be fired in

weapons of calibre not larger than 19.1 mm. Shot-gun cartridges of any calibre are included in this description.

***NOTE:** CARTRIDGES, SMALL ARMS, BLANK, are not included in this definition. They are listed separately. Some military small arms cartridges are not included in this definition. They are listed under CARTRIDGES FOR WEAPONS, INERT PROJECTILE.*

CARTRIDGES, SMALL ARMS, BLANK: UN Nos. 0014, 0327, 0338

Ammunition consisting of a closed cartridge case with a centre or rim fire primer and a charge of smokeless or black powder. The cartridge cases contain no projectiles. The cartridges are designed to be fired from weapons with a calibre of at most 19.1 mm and serve to produce a loud noise and are used for training, saluting, propelling charge, starter pistols, etc.

CASES, CARTRIDGE, EMPTY, WITH PRIMER: UN Nos. 0379; 0055

Articles consisting of a cartridge case made from metal, plastics or other non-inflammable material, in which the only explosive component is the primer.

CASES, COMBUSTIBLE, EMPTY, WITHOUT PRIMER: UN Nos. 0447, 0446

Articles consisting of a cartridge case made partly or entirely from nitrocellulose.

CHARGES, BURSTING, PLASTICS BONDED: UN Nos. 0457, 0458, 0459, 0460

Articles consisting of a charge of detonating explosive, plastics bonded, manufactured in a specific form without a casing and without means of initiation. They are designed as components of ammunition such as warheads.

CHARGES, DEMOLITION: UN No. 0048

Articles containing a charge of a detonating explosive in a casing of fibreboard, plastics, metal or other material. The articles are without means of initiation or with means of initiation containing two or more effective protective features.

***NOTE:** The following articles: BOMBS; MINES; PROJECTILES are not included in this definition. They are listed separately.*

CHARGES, DEPTH: UN No. 0056

Articles consisting of a charge of detonating explosive contained in a drum or projectile without means of initiation or with means of initiation containing two or more effective protective features. They are designed to detonate under water.

CHARGES, EXPLOSIVE, COMMERCIAL without detonator: UN Nos. 0442, 0443, 0444, 0445

Articles consisting of a charge of detonating explosive without means of initiation, used for explosive welding, jointing, forming and other metallurgical processes.

CHARGES, PROPELLING, FOR CANNON: UN Nos. 0242, 0279, 0414

Charges of propellant in any physical form for separate-loading ammunition for cannon.

CHARGES, PROPELLING: UN Nos. 0271, 0272, 0415, 0491

Articles consisting of a charge of a propellant charge in any physical form, with or without a casing, as a component of rocket motors or for reducing the drag of projectiles.

CHARGES, SHAPED, without detonator: UN Nos. 0059, 0439, 0440, 0441

Articles consisting of a casing containing a charge of detonating explosive with a cavity lined with rigid material, without means of initiation. They are designed to produce a powerful, penetrating jet effect.

CHARGES, SHAPED, FLEXIBLE, LINEAR: UN Nos. 0237, 0288

Articles consisting of a V-shaped core of a detonating explosive clad by a flexible sheath.

CHARGES, SUPPLEMENTARY, EXPLOSIVE: UN No. 0060

Articles consisting of a small removable booster placed in the cavity of a projectile between the fuze and the bursting charge.

COMPONENTS, EXPLOSIVE TRAIN, N.O.S.: UN Nos. 0382, 0383, 0384, 0461

Articles containing an explosive designed to transmit detonation or deflagration within an explosive train.

CONTRIVANCES, WATER-ACTIVATED with burster, expelling charge or propelling charge: UN Nos. 0248, 0249

Articles whose functioning depends upon physico-chemical reaction of their contents with water.

CORD, DETONATING, flexible: UN Nos. 0065, 0289

Article consisting of a core of detonating explosive enclosed in spun fabric and a plastics or other covering. The covering is not necessary if the spun fabric is sift-proof.

CORD (FUSE) DETONATING, metal clad: UN Nos. 0102, 0290

Article consisting of a core of detonating explosive clad by a soft metal tube with or without protective covering.

CORD (FUSE) DETONATING, MILD EFFECT, metal clad: UN No. 0104

Article consisting of a core of detonating explosive clad by a soft metal tube with or without a protective covering. The quantity of explosive substance is so small that only a mild effect is manifested outside the cord.

CORD, IGNITER: UN No. 0066

Article consisting of textile yarns covered with black powder or another fast burning pyrotechnic composition and of a flexible protective covering; or it consists of a core of black powder surrounded by a flexible woven fabric. It burns progressively along its length with an external flame and is used to transmit ignition from a device to a charge or primer.

CUTTERS, CABLE, EXPLOSIVE: UN No. 0070

Articles consisting of a knife-edged device which is driven by a small charge of deflagrating explosive into an anvil.

DETONATOR ASSEMBLIES, NON-ELECTRIC for blasting: UN Nos. 0360, 0361, 0500

Non-electric detonators assembled with and activated by such means as safety fuse, shock tube, flash tube or detonating cord. They may be of instantaneous design or incorporate delay elements. Detonating relays incorporating detonating cord are included.

DETONATORS, ELECTRIC for blasting: UN Nos. 0030, 0255, 0456

Articles specially designed for the initiation of blasting explosives. These detonators may be constructed to detonate instantaneously or may contain a delay element. Electric detonators are activated by an electric current.

DETONATORS FOR AMMUNITION: UN Nos. 0073, 0364, 0365, 0366

Articles consisting of a small metal or plastics tube containing explosives such as lead azide, PETN or combinations of explosives. They are designed to start a detonation train.

DETONATORS, NON-ELECTRIC for blasting: UN Nos. 0029, 0267, 0455

Articles specially designed for the initiation of blasting explosives. These detonators may be constructed to detonate instantaneously or may contain a delay element. Non-electric detonators are activated by such means as shock tube, flash tube, safety fuse, other igniferous device or flexible detonating cord. Detonating relays without detonating cord are included.

EXPLOSIVE, BLASTING, TYPE A: UN No. 0081

Substances consisting of liquid organic nitrates such as nitroglycerine or a mixture of such ingredients with one or more of the following: nitrocellulose; ammonium nitrate or other inorganic nitrates; aromatic nitro-derivatives, or combustible materials, such as wood-meal and aluminium powder. They may contain inert components such as kieselguhr, and additives such as colouring agents and stabilizers. Such explosives shall be in powdery, gelatinous or elastic form. The term includes dynamite; gelatine, blasting and gelatine dynamites.

EXPLOSIVE, BLASTING, TYPE B: UN Nos. 0082, 0331

Substances consisting of

- (a) a mixture of ammonium nitrate or other inorganic nitrates with an explosive such as trinitrotoluene, with or without other substances such as wood-meal and aluminium powder; or
- (b) a mixture of ammonium nitrate or other inorganic nitrates with other combustible substances which are not explosive ingredients. In both cases they may contain inert components such as kieselguhr, and additives such as colouring agents and stabilizers. Such explosives must not contain nitroglycerine, similar liquid organic nitrates or chlorates.

EXPLOSIVE, BLASTING, TYPE C: UN No. 0083

Substances consisting of a mixture of either potassium or sodium chlorate or potassium, sodium or ammonium perchlorate with organic nitro-derivatives or combustible materials such as wood-meal or aluminium powder or a hydrocarbon. They may contain inert components such as kieselguhr and additives such as colouring agents and stabilizers. Such explosives must not contain nitroglycerine or similar liquid organic nitrates.

EXPLOSIVE, BLASTING, TYPE D: UN No. 0084

Substances consisting of a mixture of organic nitrated compounds and combustible materials such as hydrocarbons and aluminium powder. They may contain inert components such as kieselguhr and additives such as colouring agents and stabilizers. Such explosives must not contain nitroglycerine, similar liquid organic nitrates, chlorates and ammonium nitrate. The term generally includes plastic explosives.

EXPLOSIVES, BLASTING, TYPE E: UN Nos. 0241, 0332

Substances consisting of water as an essential ingredient and high proportions of ammonium nitrate or other oxidizers, some or all of which are in solution. The other constituents may include nitro-derivatives such as trinitrotoluene, hydrocarbons or aluminium powder. They may contain inert components such as kieselguhr and additives such as colouring agents and stabilizers. The term includes explosives, emulsion, explosives, slurry and explosives, watergel.

FIREWORKS: UN Nos. 0333, 0334, 0335, 0336, 0337

Pyrotechnic articles designed for entertainment.

FLARES, AERIAL: UN Nos. 0093, 0403, 0404, 0420, 0421;

Articles containing pyrotechnic substances which are designed to be dropped from an aircraft to illuminate, identify, signal or warn.

FLARES, SURFACE: UN Nos. 0092, 0418, 0419

Articles containing pyrotechnic substances which are designed for use on the surface to illuminate, identify, signal or warn.

FLASH POWDER: UN Nos. 0094, 0305

Pyrotechnic substance which, when ignited, produces an intense light.

FRACTURING DEVICES, EXPLOSIVE without detonator, for oil wells: UN No. 0099

Articles consisting of a charge of detonating explosive contained in a casing without means of initiation. They are used to fracture the rock around a drill shaft to assist the flow of crude oil from the rock.

FUSE, IGNITER, tubular, metal clad: UN No. 0103

Article consisting of a metal tube with a core of deflagrating explosive.

FUSE, NON-DETONATING: UN No. 0101

Article consisting of cotton yarns impregnated with fine black powder (quickmatch). It burns with an external flame and is used in ignition trains for fireworks, etc.

FUSE, SAFETY: UN No. 0105

Article consisting of a core of fine grained black powder surrounded by a flexible woven fabric with one or more protective outer coverings. When ignited, it burns at a predetermined rate without any external explosive effect.

FUZES, DETONATING: UN Nos. 0106, 0107, 0257, 0367

Articles with explosive components designed to produce a detonation in ammunition. They incorporate mechanical, electrical, chemical or hydrostatic components to initiate the detonation. They generally incorporate protective features.

FUZES, DETONATING with protective features: UN Nos. 0408, 0409, 0410

Articles with explosive components designed to produce a detonation in ammunition. They incorporate mechanical, electrical, chemical or hydrostatic components to initiate the detonation. The detonating fuze must incorporate two or more effective protective features.

FUZES, IGNITING: UN Nos. 0316, 0317, 0368

Articles with primary explosive components designed to produce a deflagration in ammunition. They incorporate mechanical, electrical, chemical or hydrostatic components to start the deflagration. They generally incorporate protective features.

GRENADES, hand or rifle, with bursting charge: UN Nos. 0284, 0285

Articles which are designed to be thrown by hand or to be projected by a rifle. They are without means of initiation or with means of initiation containing two or more effective protective features.

GRENADES, hand or rifle, with bursting charge: UN Nos. 0292, 0293

Articles which are designed to be thrown by hand or to be projected by a rifle. They are with means of initiation not containing two or more effective protective features.

GRENADES, PRACTICE, hand or rifle: UN Nos. 0110, 0372, 0318, 0452

Articles without a main bursting charge which are designed to be thrown by hand or to be projected by a rifle. They contain the priming device and may contain a spotting charge.

HEXOTONAL: UN No. 0393

Substance consisting of an intimate mixture of cyclotrimethylene-trinitramine (RDX), trinitrotoluene (TNT) and aluminium.

HEXOLITE (HEXOTOL), dry or wetted with less than 15% water, by mass: UN No. 0118

Substance consisting of an intimate mixture of cyclotrimethylene-trinitramine (RDX) and trinitrotoluene (TNT). The term includes "Composition B".

IGNITERS: UN Nos. 0121, 0314, 0315, 0325, 0454

Articles containing one or more explosive substances designed to produce a deflagration in an explosive train. They may be actuated chemically, electrically or mechanically.

***NOTE:** The following articles: CORD, IGNITER; FUSE, IGNITER; FUSE, NON-DETONATING; FUZES, IGNITING; LIGHTERS, FUSE; PRIMERS, CAP TYPE; PRIMERS, TUBULAR are not included in this definition. They are listed separately.*

JET PERFORATING GUNS, CHARGED, oil well, without detonator: UN Nos. 0124, 0494

Articles consisting of a steel tube or metallic strip, into which are inserted shaped charges connected by detonating cord, without means of initiation.

LIGHTERS, FUSE: UN No. 0131

Articles of various design actuated by friction, percussion or electricity and used to ignite safety fuse.

MINES with bursting charge: UN Nos. 0137, 0138

Articles consisting normally of metal or composition receptacles filled with a detonating explosive, without means of initiation or with means of initiation containing two or more effective protective features. They are designed to be operated by the passage of ships, vehicles or personnel. The term includes "Bangalore torpedoes".

MINES with bursting charge: UN Nos. 0136, 0294

Articles consisting normally of metal or composition receptacles filled with a detonating explosive, with means of initiation not containing two or more effective protective features. They are designed to be operated by the passage of ships, vehicles or personnel. The term includes "Bangalore torpedoes".

OCTOLITE (OCTOL), dry or wetted with less than 15% water, by mass: UN No. 0266

Substance consisting of an intimate mixture of cyclotetramethylene-tetranitramine (HMX) and trinitrotoluene (TNT).

OCTONAL: UN No. 0496

Substance consisting of an intimate mixture of cyclotetramethylenetetranitramine (HMX), trinitrotoluene (TNT) and aluminium.

PENTOLITE, dry or wetted with less than 15% water, by mass: UN No. 0151

Substance consisting of an intimate mixture of pentaerythrite tetranitrate (PETN) and trinitrotoluene (TNT).

POWDER CAKE (POWDER PASTE), WETTED with not less than 17% alcohol, by mass;
POWDER CAKE (POWDER PASTE), WETTED with not less than 25% water, by mass:
UN Nos. 0433, 0159

Substance consisting of nitrocellulose impregnated with not more than 60% of nitroglycerine or other liquid organic nitrates or a mixture of these.

POWDER, SMOKELESS: UN Nos. 0160, 0161, 0509

Substance based on nitrocellulose used as propellant. The term includes propellants with a single base (nitrocellulose (NC) alone), those with a double base (such as NC and nitroglycerine/(NG)) and those with a triple base (such as NC/NG/nitroguanidine).

***NOTE:** Cast, pressed or bag-charges of smokeless powder are listed under CHARGES, PROPELLING or CHARGES, PROPELLING, FOR CANON.*

PRIMERS, CAP TYPE: UN Nos. 0044, 0377, 0378

Articles consisting of a metal or plastics cap containing a small amount of primary explosive mixture that is readily ignited by impact. They serve as igniting elements in small arms cartridges and in percussion primers for propelling charges.

PRIMERS, TUBULAR: UN Nos. 0319, 0320, 0376

Articles consisting of a primer for ignition and an auxiliary charge of deflagrating explosive such as black powder used to ignite the propelling charge in a cartridge case for cannon, etc.

PROJECTILES, inert with tracer: UN Nos. 0345, 0424, 0425

Articles such as a shell or bullet, which are projected from a cannon or other gun, rifle or other small arm.

PROJECTILES with burster or expelling charge: UN Nos. 0346, 0347

Articles such as a shell or bullet, which are projected from a cannon or other gun. They are without means of initiation or with means of initiation containing two or more effective protective features. They are used to scatter dyes for spotting or other inert materials.

PROJECTILES with burster or expelling charge: UN Nos. 0426, 0427

Articles such as a shell or bullet, which are projected from a cannon or other gun. They are with means of initiation not containing two or more effective protective features. They are used to scatter dyes for spotting or other inert materials.

PROJECTILES with burster or expelling charge: UN Nos. 0434, 0435

Articles such as a shell or bullet, which are projected from a cannon or other gun, rifle or other small arm. They are used to scatter dyes for spotting or other inert materials.

PROJECTILES with bursting charge: UN Nos. 0168, 0169, 0344

Articles such as a shell or bullet, which are projected from a cannon or other gun. They are without means of initiation or with means of initiation containing two or more effective protective features.

PROJECTILES with bursting charge: UN Nos. 0167, 0324

Articles such as a shell or bullet, which are projected from a cannon or other gun. They are with means of initiation not containing two or more effective protective features.

PROPELLANT, LIQUID: UN Nos. 0495, 0497

Substance consisting of a deflagrating liquid explosive, used for propulsion.

PROPELLANT, SOLID: UN Nos. 0498, 0499, 0501

Substance consisting of a deflagrating solid explosive, used for propulsion.

RELEASE DEVICES, EXPLOSIVE: UN No. 0173

Articles consisting of a small charge of explosive with means of initiation and rods or links. They sever the rods or links to release equipment quickly.

RIVETS, EXPLOSIVE: UN No. 0174

Articles consisting of a small charge of explosive inside a metallic rivet.

ROCKET MOTORS: UN Nos. 0186, 0280, 0281

Articles consisting of a charge of explosive, generally a solid propellant, contained in a cylinder fitted with one or more nozzles. They are designed to propel a rocket or a guided missile.

ROCKET MOTORS, LIQUID FUELLED: UN Nos. 0395, 0396

Articles consisting of a liquid fuel within a cylinder fitted with one or more nozzles. They are designed to propel a rocket or a guided missile.

ROCKET MOTORS WITH HYPERGOLIC LIQUIDS with or without expelling charge: UN Nos. 0322, 0250

Articles consisting of a hypergolic fuel contained in a cylinder fitted with one or more nozzles. They are designed to propel a rocket or a guided missile.

ROCKETS, LINE THROWING: UN Nos. 0238, 0240, 0453

Articles consisting of a rocket motor which is designed to extend a line.

ROCKETS, LIQUID FUELLED with bursting charge: UN Nos. 0397, 0398

Articles consisting of a liquid fuel within a cylinder fitted with one or more nozzles and fitted with a warhead. The term includes guided missiles.

ROCKETS with bursting charge: UN Nos. 0181, 0182

Articles consisting of a rocket motor and a warhead without means of initiation or with means of initiation containing two or more effective protective features. The term includes guided missiles.

ROCKETS with bursting charge: UN Nos. 0180, 0295

Articles consisting of a rocket motor and a warhead with means of initiation not containing two or more effective protective features. The term includes guided missiles.

ROCKETS with expelling charge: UN Nos. 0436, 0437, 0438

Articles consisting of a rocket motor and a charge to expel the payload from a rocket head. The term includes guided missiles.

ROCKETS with inert head: UN Nos. 0183, 0502

Articles consisting of a rocket motor and an inert head. The term includes guided missiles.

SAMPLES, EXPLOSIVE, other than initiating explosive UN No. 0190

New or existing explosive substances or articles, not yet assigned to a name in Table A of Chapter 3.2 and carried in conformity with the instructions of the competent authority and generally in small quantities, *inter alia*, for the purposes of testing, classification, research and development, or quality control, or as commercial samples.

NOTE: Explosive substances or articles already assigned to another name in Table A of Chapter 3.2 are not included in this definition.

SIGNAL DEVICES, HAND: UN Nos. 0191, 0373

Portable articles containing pyrotechnic substances which produce visual signals or warnings. The term includes small surface flares such as highway or railway flares and small distress flares.

SIGNALS, DISTRESS, ship: UN Nos. 0194, 0195, 0505, 0506

Articles containing pyrotechnic substances designed to produce signals by means of sound, flame or smoke or any combination thereof.

SIGNALS, RAILWAY TRACK, EXPLOSIVE: UN Nos. 0192, 0193, 0492, 0493

Articles containing a pyrotechnic substance which explodes with a loud report when the article is crushed. They are designed to be placed on a rail.

SIGNALS, SMOKE: UN Nos. 0196, 0197, 0313, 0487, 0507

Articles containing pyrotechnic substances which emit smoke. In addition they may contain devices for emitting audible signals.

SOUNDING DEVICES, EXPLOSIVE: UN Nos. 0374, 0375

Articles consisting of a charge of detonating explosive, without means of initiation or with means of initiation containing two or more effective protective features. They are dropped from ships and function when they reach a predetermined depth or the sea bed.

SOUNDING DEVICES, EXPLOSIVE: UN Nos. 0204, 0296

Articles consisting of a charge of detonating explosive with means of initiation not containing two or more effective protective features. They are dropped from ships and function when they reach a predetermined depth or the sea bed.

SUBSTANCES, EXPLOSIVE, VERY INSENSITIVE (Substances, EVI), N.O.S.: UN No. 0482

Substances presenting a mass explosion hazard but which are so insensitive that there is very little probability of initiation or of transition from burning to detonation under normal conditions of transport, and which have passed Test Series 5.

TORPEDOES, LIQUID FUELLED with inert head: UN No. 0450

Articles consisting of a liquid explosive system to propel the torpedo through the water, with an inert head.

TORPEDOES, LIQUID FUELLED with or without bursting charge: UN No. 0449

Articles consisting of either a liquid explosive system to propel the torpedo through the water, with or without a warhead; or a liquid non-explosive system to propel the torpedo through the water, with a warhead.

TORPEDOES with bursting charge: UN No. 0451

Articles consisting of a non-explosive system to propel the torpedo through the water, and a warhead without means of initiation or with means of initiation containing two or more effective protective features.

TORPEDOES with bursting charge: UN No. 0329

Articles consisting of an explosive system to propel the torpedo through the water, and a warhead without means of initiation or with means of initiation containing two or more effective protective features.

TORPEDOES with bursting charge: UN No. 0330

Articles consisting of an explosive or non-explosive system to propel the torpedo through the water, and a warhead with means of initiation not containing two or more effective protective features.

TRACERS FOR AMMUNITION: UN Nos. 0212, 0306

Sealed articles containing pyrotechnic substances, designed to reveal the trajectory of a projectile.

TRITONAL: UN No. 0390

Substance consisting of trinitrotoluene (TNT) mixed with aluminium.

WARHEADS, ROCKET with burster or expelling charge: UN No. 0370

Articles consisting of an inert payload and a small charge of detonating or deflagrating explosive, without means of initiation or with means of initiation containing two or more effective protective features. They are designed to be fitted to a rocket motor to scatter inert material. The term includes warheads for guided missiles.

WARHEADS, ROCKET with burster or expelling charge: UN No. 0371

Articles consisting of an inert payload and a small charge of detonating or deflagrating explosive, with means of initiation not containing two or more effective protective features. They are designed to be fitted to a rocket motor to scatter inert material. The term includes warheads for guided missiles.

WARHEADS, ROCKET with bursting charge: UN Nos. 0286, 0287

Articles consisting of a detonating explosive, without means of initiation or with means of initiation containing two or more effective protective features. They are designed to be fitted to a rocket. The term includes warheads for guided missiles.

WARHEADS, ROCKET with bursting charge: UN No. 0369

Articles consisting of a detonating explosive, with means of initiation not containing two or more effective protective features. They are designed to be fitted to a rocket. The term includes warheads for guided missiles.

WARHEADS, TORPEDO with bursting charge: UN No. 0221

Articles consisting of a detonating explosive, without means of initiation or with means of initiation containing two or more effective protective features. They are designed to be fitted to a torpedo.

2.2.1.2 *Substances and articles not accepted for carriage*

2.2.1.2.1 Explosive substances which are unduly sensitive according to the criteria of the Manual of Tests and Criteria, Part I, or are liable to spontaneous reaction, as well as explosive substances and articles which cannot be assigned to a name or n.o.s. entry listed in Table A of Chapter 3.2, shall not be accepted for carriage.

2.2.1.2.2 Articles of compatibility group K shall not be accepted for carriage (1.2K, UN No. 0020 and 1.3K, UN No. 0021).

2.2.1.3 *List of collective entries*

Classification code (see 2.2.1.1.4)	UN No.	Name of the substance or article
1.1A	0473	SUBSTANCES, EXPLOSIVE, N.O.S.
1.1B	0461	COMPONENTS, EXPLOSIVE TRAIN, N.O.S.
1.1C	0474	SUBSTANCES, EXPLOSIVE, N.O.S.
	0497	PROPELLANT, LIQUID
	0498	PROPELLANT, SOLID
	0462	ARTICLES, EXPLOSIVE, N.O.S.
1.1D	0475	SUBSTANCES, EXPLOSIVE, N.O.S.
	0463	ARTICLES, EXPLOSIVE, N.O.S.
1.1E	0464	ARTICLES, EXPLOSIVE, N.O.S.
1.1F	0465	ARTICLES, EXPLOSIVE, N.O.S.
1.1G	0476	SUBSTANCES, EXPLOSIVE, N.O.S.
1.1L	0357	SUBSTANCES, EXPLOSIVE, N.O.S.
	0354	ARTICLES, EXPLOSIVE, N.O.S.
1.2B	0382	COMPONENTS, EXPLOSIVE TRAIN, N.O.S.
1.2C	0466	ARTICLES, EXPLOSIVE, N.O.S.
1.2D	0467	ARTICLES, EXPLOSIVE, N.O.S.
1.2E	0468	ARTICLES, EXPLOSIVE, N.O.S.
1.2F	0469	ARTICLES, EXPLOSIVE, N.O.S.
1.2L	0358	SUBSTANCES, EXPLOSIVE, N.O.S.
	0248	CONTRIVANCES, WATER-ACTIVATED with burster, expelling charge or propelling charge
	0355	ARTICLES, EXPLOSIVE, N.O.S.
1.3C	0132	DEFLAGRATING METAL SALTS OF AROMATIC NITRO-DERIVATIVES, N.O.S.
	0477	SUBSTANCES, EXPLOSIVE, N.O.S.
	0495	PROPELLANT, LIQUID
	0499	PROPELLANT, SOLID
	0470	ARTICLES, EXPLOSIVE, N.O.S.
1.3G	0478	SUBSTANCES, EXPLOSIVE, N.O.S.
1.3L	0359	SUBSTANCES, EXPLOSIVE, N.O.S.
	0249	CONTRIVANCES, WATER-ACTIVATED with burster, expelling charge or propelling charge
	0356	ARTICLES, EXPLOSIVE, N.O.S.
1.4B	0350	ARTICLES, EXPLOSIVE, N.O.S.
	0383	COMPONENTS, EXPLOSIVE TRAIN, N.O.S.
1.4C	0479	SUBSTANCES, EXPLOSIVE, N.O.S.
	0501	PROPELLANT, SOLID
	0351	ARTICLES, EXPLOSIVE, N.O.S.

Classification code (see 2.2.1.1.4)	UN No.	Name of the substance or article
1.4D	0480	SUBSTANCES, EXPLOSIVE, N.O.S.
	0352	ARTICLES, EXPLOSIVE, N.O.S.
1.4E	0471	ARTICLES, EXPLOSIVE, N.O.S.
1.4F	0472	ARTICLES, EXPLOSIVE, N.O.S.
1.4G	0485	SUBSTANCES, EXPLOSIVE, N.O.S.
	0353	ARTICLES, EXPLOSIVE, N.O.S.
1.4S	0481	SUBSTANCES, EXPLOSIVE, N.O.S.
	0349	ARTICLES, EXPLOSIVE, N.O.S.
	0384	COMPONENTS, EXPLOSIVE TRAIN, N.O.S.
1.5D	0482	SUBSTANCES, EXPLOSIVE, VERY INSENSITIVE (SUBSTANCES, EVI) N.O.S.
1.6N	0486	ARTICLES, EXPLOSIVE, EXTREMELY INSENSITIVE (ARTICLES, EEI)
	0190	SAMPLES, EXPLOSIVE other than initiating explosive <i>NOTE: Division and Compatibility Group shall be defined as directed by the competent authority and according to the principles in 2.2.1.1.4.</i>

2.2.2 Class 2 Gases

2.2.2.1 Criteria

2.2.2.1.1 The heading of Class 2 covers pure gases, mixtures of gases, mixtures of one or more gases with one or more other substances and articles containing such substances.

A gas is a substance which:

- (a) at 50 °C has a vapour pressure greater than 300 kPa (3 bar); or
- (b) is completely gaseous at 20 °C at the standard pressure of 101.3 kPa.

NOTE 1: *UN No. 1052 HYDROGEN FLUORIDE, ANHYDROUS is nevertheless classified in Class 8.*

NOTE 2: *A pure gas may contain other components deriving from its production process or added to preserve the stability of the product, provided that the level of these components does not change its classification or its conditions of carriage, such as filling ratio, filling pressure, test pressure.*

NOTE 3: *N.O.S. entries in 2.2.2.3 may cover pure gases as well as mixtures.*

2.2.2.1.2 The substances and articles of Class 2 are subdivided as follows:

1. *Compressed gas:* a gas which when packaged under pressure for carriage is entirely gaseous at -50 °C; this category includes all gases with a critical temperature less than or equal to -50 °C;
2. *Liquefied gas:* a gas which when packaged under pressure for carriage is partially liquid at temperatures above -50 °C. A distinction is made between:

High pressure liquefied gas: a gas with a critical temperature above -50 °C and equal to or below +65 °C; and

Low pressure liquefied gas: a gas with a critical temperature above +65 °C;

3. *Refrigerated liquefied gas:* a gas which when packaged for carriage is made partially liquid because of its low temperature;
4. *Dissolved gas:* a gas which when packaged under pressure for carriage is dissolved in a liquid phase solvent;
5. Aerosol dispensers and receptacles, small, containing gas (gas cartridges);
6. Other articles containing gas under pressure;
7. Non-pressurized gases subject to special requirements (gas samples).

2.2.2.1.3 Substances and articles (except aerosols) of Class 2 are assigned to one of the following groups according to their hazardous properties, as follows:

- A asphyxiant;
- O oxidizing;

- F flammable;
- T toxic;
- TF toxic, flammable;
- TC toxic, corrosive;
- TO toxic, oxidizing;
- TFC toxic, flammable, corrosive;
- TOC toxic, oxidizing, corrosive.

For gases and gas mixtures presenting hazardous properties associated with more than one group according to the criteria, the groups designated by letter T take precedence over all other groups. The groups designated by letter F take precedence over the groups designated by letters A or O.

NOTE 1: *In the UN Model Regulations, the IMDG Code and the ICAO Technical Instructions, gases are assigned to one of the following three divisions, based on the primary hazard:*

- Division 2.1: flammable gases (corresponding to the groups designated by the capital letter F);*
- Division 2.2: non-flammable, non-toxic gases (corresponding to the groups designated by the capital letters A or O);*
- Division 2.3: toxic gases (corresponding to the groups designated by the capital letter T i.e. T, TF, TC, TO, TFC and TOC).*

NOTE 2: *Receptacles, small containing gas (UN No. 2037) shall be assigned to the groups A to TOC according to the hazard of the contents. For aerosols (UN No. 1950), see 2.2.2.1.6.*

NOTE 3: *Corrosive gases are considered to be toxic, and are therefore assigned to the group TC, TFC or TOC.*

2.2.2.1.4 If a mixture of Class 2 mentioned by name in Table A of Chapter 3.2 meets different criteria as mentioned in 2.2.2.1.2 and 2.2.2.1.5, this mixture shall be classified according to the criteria and assigned to an appropriate N.O.S. entry.

2.2.2.1.5 Substances and articles (except aerosols) of Class 2 which are not mentioned by name in Table A of Chapter 3.2 shall be classified under a collective entry listed in 2.2.2.3 in accordance with 2.2.2.1.2 and 2.2.2.1.3. The following criteria shall apply:

Asphyxiant gases

Gases which are non-oxidizing, non-flammable and non-toxic and which dilute or replace oxygen normally in the atmosphere.

Flammable gases

Gases which at 20 °C and a standard pressure of 101.3 kPa:

- (a) are ignitable when in a mixture of 13% or less by volume with air; or

- (b) have a flammable range with air of at least 12 percentage points regardless of the lower flammable limit.

Flammability shall be determined by tests or by calculation, in accordance with methods adopted by ISO (see ISO 10156:1996).

Where insufficient data are available to use these methods, tests by a comparable method recognized by the competent authority of the country of origin may be used.

If the country of origin is not a Contracting Party to ADR these methods shall be recognized by the competent authority of the first country Contracting Party to ADR reached by the consignment.

Oxidizing gases

Gases, which may, generally by providing oxygen, cause or contribute to the combustion of other material more than air does. These are pure gases or gas mixtures with an oxidizing power greater than 23.5% as determined by a method specified in ISO 10156:1996 or ISO 10156-2:2005.

Toxic gases

NOTE: *Gases meeting the criteria for toxicity in part or completely owing to their corrosivity are to be classified as toxic. See also the criteria under the heading "Corrosive gases" for a possible subsidiary corrosivity risk.*

Gases which:

- (a) are known to be so toxic or corrosive to humans as to pose a hazard to health; or
- (b) are presumed to be toxic or corrosive to humans because they have a LC₅₀ value for acute toxicity equal to or less than 5 000 ml/m³ (ppm) when tested in accordance with 2.2.61.1.

In the case of gas mixtures (including vapours of substances from other classes) the following formula may be used:

$$LC_{50} \text{ Toxic (mixture)} = \frac{1}{\sum_{i=1}^n \frac{f_i}{T_i}}$$

where f_i = mole fraction of the i^{th} component substance of the mixture;
 T_i = toxicity index of the i^{th} component substance of the mixture.

The T_i equals the LC₅₀ value as found in packing instruction P200 of 4.1.4.1.

When no LC₅₀ value is listed in packing instruction P200 of 4.1.4.1, a LC₅₀ value available in scientific literature shall be used. When the LC₅₀ value is unknown, the toxicity index is determined by using the lowest LC₅₀ value of substances of similar physiological and chemical effects, or through testing if this is the only practical possibility.

Corrosive gases

Gases or gas mixtures meeting the criteria for toxicity completely owing to their corrosivity are to be classified as toxic with a subsidiary corrosivity risk.

A gas mixture that is considered to be toxic due to the combined effects of corrosivity and toxicity has a subsidiary risk of corrosivity when the mixture is known by human experience to be destructive to the skin, eyes or mucous membranes or when the LC₅₀ value of the corrosive components of the mixture is equal to or less than 5 000 ml/m³ (ppm) when the LC₅₀ is calculated by the formula:

$$LC_{50} \text{ Corrosive (mixture)} = \frac{1}{\sum_{i=1}^n \frac{f_{ci}}{T_{ci}}}$$

where f_{ci} = mole fraction of the i^{th} corrosive component substance of the mixture;

T_{ci} = toxicity index of the i^{th} corrosive component substance of the mixture.

The T_{ci} equals the LC₅₀ value as found in packing instruction P200 of 4.1.4.1.

When no LC₅₀ value is listed in packing instruction P200 of 4.1.4.1, a LC₅₀ value available in scientific literature shall be used.

When the LC₅₀ value is unknown the toxicity index is determined by using the lowest LC₅₀ value of substances of similar physiological and chemical effects, or through testing if this is the only practical possibility.

2.2.2.1.6 *Aerosols*

Aerosols (UN No. 1950) are assigned to one of the following groups according to their hazardous properties, as follows:

A	asphyxiant;
O	oxidizing;
F	flammable;
T	toxic;
C	corrosive;
CO	corrosive, oxidizing;
FC	flammable, corrosive;
TF	toxic, flammable;
TC	toxic, corrosive;
TO	toxic, oxidizing;
TFC	toxic, flammable, corrosive;

TOC toxic, oxidizing, corrosive.

The classification depends on the nature of the contents of the aerosol dispenser.

NOTE: *Gases, which meet the definition of toxic gases according to 2.2.2.1.5 or of pyrophoric gases according to packing instruction P200 in 4.1.4.1, shall not be used as a propellant in an aerosol dispenser. Aerosols with contents meeting the criteria for packing group I for toxicity or corrosivity shall not be accepted for carriage (see also 2.2.2.2.2).*

The following criteria shall apply:

- (a) Assignment to group A shall apply when the contents do not meet the criteria for any other group according to sub-paragraphs (b) to (f) below;
- (b) Assignment to group O shall apply when the aerosol contains an oxidizing gas according to 2.2.2.1.5;
- (c) Assignment to group F shall apply if the contents include 85% by mass or more flammable components and the chemical heat of combustion is 30 kJ/g or more.

It shall not apply if the contents contain 1% by mass or less flammable components and the heat of combustion is less than 20 kJ/g.

Otherwise the aerosol shall be tested for flammability in accordance with the tests described in the *Manual of Tests and Criteria*, Part III, section 31. Extremely flammable and flammable aerosols shall be assigned to group F;

NOTE: *Flammable components are flammable liquids, flammable solids or flammable gases and gas mixtures as defined in Notes 1 to 3 of sub-section 31.1.3 of Part III of the Manual of Tests and Criteria. This designation does not cover pyrophoric, self-heating or water-reactive substances. The chemical heat of combustion shall be determined by one of the following methods ASTM D 240, ISO/FDIS 13943:1999 (E/F) 86.1 to 86.3 or NFPA 30B.*

- (d) Assignment to group T shall apply when the contents, other than the propellant of aerosol dispensers to be ejected, are classified as Class 6.1, packing groups II or III;
- (e) Assignment to group C shall apply when the contents, other than the propellant of aerosol dispensers to be ejected, meet the criteria for Class 8, packing groups II or III;
- (f) When the criteria for more than one group amongst groups O, F, T, and C are met, assignment to groups CO, FC, TF, TC TO, TFC or TOC shall apply, as relevant.

2.2.2.2 Gases not accepted for carriage

2.2.2.2.1 Chemically unstable substances of Class 2 shall not be accepted for carriage, unless the necessary steps have been taken to prevent all possibility of a dangerous reaction e.g. decomposition, dismutation or polymerisation under normal conditions during transport. To this end particular care shall be taken to ensure that receptacles and tanks do not contain any substances liable to promote these reactions.

2.2.2.2.2 The following substances and mixtures shall not be accepted for carriage:

- UN No. 2186 HYDROGEN CHLORIDE, REFRIGERATED LIQUID;

- UN No. 2421 NITROGEN TRIOXIDE;
- UN No. 2455 METHYL NITRITE;
- Refrigerated liquefied gases which cannot be assigned to classification codes 3A, 3O or 3F;
- Dissolved gases which cannot be classified under UN Nos. 1001, 2073 or 3318;
- Aerosols where gases which are toxic according to 2.2.2.1.5 or pyrophoric according to packing instruction P200 in 4.1.4.1 are used as propellants;
- Aerosols with contents meeting the criteria for packing group I for toxicity or corrosivity (see 2.2.61 and 2.2.8);
- Receptacles, small, containing gases which are very toxic (LC₅₀ lower than 200 ppm) or pyrophoric according to packing instruction P200 in 4.1.4.1.

2.2.2.3 *List of collective entries*

Compressed gases		
Classification code	UN No.	Name of the substance or article
1 A	1956	COMPRESSED GAS, N.O.S.
1 O	3156	COMPRESSED GAS, OXIDIZING, N.O.S.
1 F	1964	HYDROCARBON GAS MIXTURE, COMPRESSED, N.O.S.
	1954	COMPRESSED GAS, FLAMMABLE, N.O.S.
1T	1955	COMPRESSED GAS, TOXIC, N.O.S.
1 TF	1953	COMPRESSED GAS, TOXIC, FLAMMABLE, N.O.S.
1 TC	3304	COMPRESSED GAS, TOXIC, CORROSIVE, N.O.S.
1 TO	3303	COMPRESSED GAS, TOXIC, OXIDIZING, N.O.S.
1 TFC	3305	COMPRESSED GAS, TOXIC, FLAMMABLE, CORROSIVE, N.O.S.
1 TOC	3306	COMPRESSED GAS, TOXIC, OXIDIZING, CORROSIVE, N.O.S.

Liquefied gases		
Classification code	UN No.	Name of the substance or article
2 A	1058 1078	LIQUEFIED GASES, non-flammable, charged with nitrogen, carbon dioxide or air REFRIGERANT GAS, N.O.S. such as mixtures of gases, indicated by the letter R..., which as: Mixture F1, have a vapour pressure at 70 °C not exceeding 1.3 MPa (13 bar) and a density at 50 °C not lower than that of dichlorofluoromethane (1.30 kg/l); Mixture F2, have a vapour pressure at 70 °C not exceeding 1.9 MPa (19 bar) and a density at 50 °C not lower than that of dichlorodifluoromethane (1.21 kg/l); Mixture F3, have a vapour pressure at 70 °C not exceeding 3 MPa (30 bar) and a density at 50 °C not lower than that of chlorodifluoromethane (1.09 kg/l). NOTE: Trichlorofluoromethane (Refrigerant R 11), 1,1,2-trichloro-1,2,2-trifluoroethane (Refrigerant R 113), 1,1,1-trichloro-2,2,2-trifluoroethane (Refrigerant R 113a), 1-chloro-1,2,2-trifluoroethane (Refrigerant R 133) and 1-chloro-1,1,2-trifluoroethane (Refrigerant R 133b) are not substances of Class 2. They may, however, enter into the composition of mixtures F1 to F3.
	1968	INSECTICIDE GAS, N.O.S.
	3163	LIQUEFIED GAS, N.O.S.
2 O	3157	LIQUEFIED GAS, OXIDIZING, N.O.S.
2 F	1010	BUTADIENES AND HYDROCARBON MIXTURE, STABILIZED, having a vapour pressure at 70 °C not exceeding 1.1 MPa (11 bar) and a density at 50 °C not lower than 0.525 kg/l. NOTE: Butadienes, stabilized are also classified under UN No. 1010, see Table A of Chapter 3.2.
	1060	METHYLACETYLENE AND PROPADIENE MIXTURE, STABILIZED such as mixtures of methylacetylene and propadiene with hydrocarbons, which as: Mixture P1, contain not more than 63% methylacetylene and propadiene by volume and not more than 24% propane and propylene by volume, the percentage of C ₄ - saturated hydrocarbons being not less than 14% by volume; and as Mixture P2, contain not more than 48% methylacetylene and propadiene by volume and not more than 50% propane and propylene by volume, the percentage of C ₄ - saturated hydrocarbons being not less than 5% by volume, as well as mixtures of propadiene with 1 to 4% methylacetylene.

Liquefied gases (cont'd)		
Classification code	UN No.	Name of the substance or article
2 F <i>(cont'd)</i>	1965	HYDROCARBON GAS MIXTURE, LIQUEFIED, N.O.S. such as mixtures, which as: Mixture A, have a vapour pressure at 70 °C not exceeding 1.1 MPa (11 bar) and a density at 50 °C not lower than 0.525 kg/l; Mixture A01, have a vapour pressure at 70 °C not exceeding 1.6 MPa (16 bar) and a relative density at 50 °C not lower than 0.516 kg/l; Mixture A02, have a vapour pressure at 70 °C not exceeding 1.6 MPa (16 bar) and a relative density at 50 °C not lower than 0.505 kg/l; Mixture A0, have a vapour pressure at 70 °C not exceeding 1.6 MPa (16 bar) and a density at 50 °C not lower than 0.495 kg/l; Mixture A1, have a vapour pressure at 70 °C not exceeding 2.1 MPa (21 bar) and a density at 50 °C not lower than 0.485 kg/l; Mixture B1 have a vapour pressure at 70 °C not exceeding 2.6 MPa (26 bar) and a relative density at 50 °C not lower than 0.474 kg/l; Mixture B2 have a vapour pressure at 70 °C not exceeding 2.6 MPa (26 bar) and a relative density at 50 °C not lower than 0.463 kg/l; Mixture B, have a vapour pressure at 70 °C not exceeding 2.6 MPa (26 bar) and a density at 50 °C not lower than 0.450 kg/l; Mixture C, have a vapour pressure at 70 °C not exceeding 3.1 MPa (31 bar) and a relative density at 50 °C not lower than 0.440 kg/l; NOTE 1: <i>In the case of the foregoing mixtures, the use of the following names customary in the trade is permitted for describing these substances: for mixtures A, A01, A02 and A0: BUTANE; for mixture C: PROPANE.</i> NOTE 2: <i>UN No. 1075 PETROLEUM GASES, LIQUEFIED may be used as an alternative entry for UN No. 1965 HYDROCARBON GAS MIXTURE LIQUEFIED, N.O.S. for carriage prior to or following maritime or air carriage.</i>
	3354	INSECTICIDE GAS, FLAMMABLE, N.O.S.
	3161	LIQUEFIED GAS, FLAMMABLE, N.O.S.
	2 T	1967
	3162	LIQUEFIED GAS, TOXIC, N.O.S.
2 TF	3355	INSECTICIDE GAS, TOXIC, FLAMMABLE, N.O.S.
	3160	LIQUEFIED GAS, TOXIC, FLAMMABLE, N.O.S.
2 TC	3308	LIQUEFIED GAS, TOXIC, CORROSIVE, N.O.S.
2 TO	3307	LIQUEFIED GAS, TOXIC, OXIDIZING, N.O.S.
2 TFC	3309	LIQUEFIED GAS, TOXIC, FLAMMABLE, CORROSIVE, N.O.S.
2 TOC	3310	LIQUEFIED GAS, TOXIC, OXIDIZING, CORROSIVE, N.O.S.

Refrigerated liquefied gases		
Classification code	UN No.	Name of the substance or article
3 A	3158	GAS, REFRIGERATED LIQUID, N.O.S.
3 O	3311	GAS, REFRIGERATED LIQUID, OXIDIZING, N.O.S.
3 F	3312	GAS, REFRIGERATED LIQUID, FLAMMABLE, N.O.S.

Dissolved gases		
Classification code	UN No.	Name of the substance or article
4		Only substances listed in Table A of Chapter 3.2 are to be accepted for carriage.

Aerosols and receptacles, small, containing gas		
Classification code	UN No.	Name of the substance or article
5	1950	AEROSOLS
	2037	RECEPTACLES, SMALL CONTAINING GAS (GAS CARTRIDGES) without a release device, non-refillable

Other articles containing gas under pressure		
Classification code	UN No.	Name of the substance or article
6A	2857	REFRIGERATING MACHINES containing non-flammable, non-toxic gases or ammonia solutions (UN 2672)
	3164	ARTICLES, PRESSURIZED, PNEUMATIC (containing non-flammable gas) or
	3164	ARTICLES, PRESSURIZED, HYDRAULIC (containing non-flammable gas)
6F	3150	DEVICES, SMALL, HYDROCARBON GAS POWERED or
	3150	HYDROCARBON GAS REFILLS FOR SMALL DEVICES, with release device
	3478	FUEL CELL CARTRIDGES, containing liquefied flammable gas or
	3478	FUEL CELL CARTRIDGES CONTAINED IN EQUIPMENT, containing liquefied flammable gas or
	3478	FUEL CELL CARTRIDGES PACKED WITH EQUIPMENT, containing liquefied flammable gas
	3479	FUEL CELL CARTRIDGES, containing hydrogen in metal hydride or
	3479	FUEL CELL CARTRIDGES CONTAINED IN EQUIPMENT, containing hydrogen in metal hydride or
3479	FUEL CELL CARTRIDGES PACKED WITH EQUIPMENT, containing hydrogen in metal hydride	

Gas samples		
Classification code	UN No.	Name of the substance or article
7 F	3167	GAS SAMPLE, NON-PRESSURIZED, FLAMMABLE, N.O.S., not refrigerated liquid
7 T	3169	GAS SAMPLE, NON-PRESSURIZED, TOXIC, N.O.S., not refrigerated liquid
7 TF	3168	GAS SAMPLE, NON-PRESSURIZED, TOXIC, FLAMMABLE, N.O.S., not refrigerated liquid

2.2.3 Class 3 Flammable liquids**2.2.3.1 Criteria**

2.2.3.1.1 The heading of Class 3 covers substances and articles containing substances of this Class which:

- are liquids according to subparagraph (a) of the definition for "liquid" in 1.2.1;
- have at 50 °C a vapour pressure of not more than 300 kPa (3 bar) and are not completely gaseous at 20 °C and at standard pressure of 101.3 kPa; and
- have a flash-point of not more than 60 °C (see 2.3.3.1 for the relevant test).

The heading of Class 3 also covers liquid substances and molten solid substances with a flash-point of more than 60°C and which are carried or handed over for carriage whilst heated at temperatures equal to or higher than their flash-point. These substances are assigned to UN No. 3256.

The heading of Class 3 also covers liquid desensitized explosives. Liquid desensitized explosives are explosive substances which are dissolved or suspended in water or other liquid substances, to form an homogeneous liquid mixture to suppress their explosive properties. Such entries in Table A of Chapter 3.2 are UN Nos. 1204, 2059, 3064, 3343, 3357 and 3379.

NOTE 1: *Substances having a flash-point above 35 °C, non-toxic and non-corrosive, which do not sustain combustion according to the criteria of sub-section 32.2.5 of Part III of the Manual of Tests and Criteria, are not substances of Class 3; if, however, these substances are handed over for carriage and carried whilst heated at temperatures equal to or higher than their flash-point, they are substances of Class 3.*

NOTE 2: *By derogation from paragraph 2.2.3.1.1 above, diesel fuel, gasoil, heating oil (light) having a flash-point above 60 °C and not more than 100 °C shall be deemed substances of Class 3, UN No. 1202.*

NOTE 3: *Liquids which are highly toxic on inhalation, having a flash-point below 23 °C and toxic substances, having a flash-point of 23 °C or above are substances of Class 6.1 (see 2.2.61.1).*

NOTE 4: *Flammable liquid substances and preparations used as pesticides, which are highly toxic, toxic or slightly toxic and have a flash-point of 23 °C or above are substances of Class 6.1 (see 2.2.61.1).*

2.2.3.1.2 The substances and articles of Class 3 are subdivided as follows:

F Flammable liquids, without subsidiary risk:

F1 Flammable liquids having a flash-point of or below 60 °C;

F2 Flammable liquids having a flash-point above 60 °C which are carried or handed over for carriage at or above their flash-point (elevated temperature substances);

FT Flammable liquids, toxic:

FT1 Flammable liquids, toxic;

FT2 Pesticides;

FC Flammable liquids, corrosive;

FTC Flammable liquids, toxic, corrosive;

D Liquid desensitized explosives.

2.2.3.1.3 Substances and articles classified in Class 3 are listed in Table A of Chapter 3.2. Substances not mentioned by name in Table A of Chapter 3.2 shall be assigned to the relevant entry of 2.2.3.3 and the relevant packing group in accordance with the provisions of this section. Flammable liquids shall be assigned to one of the following packing groups according to the degree of danger they present for carriage:

Packing group	Flash point (closed cup)	Initial boiling point
I	--	≤ 35°C
II ^a	< 23°C	> 35°C
III ^a	≥ 23°C ≤ 60°C	> 35°C

^a See also 2.2.3.1.4.

For a liquid with (a) subsidiary risk(s), the packing group determined in accordance with the table above and the packing group based on the severity of the subsidiary risk(s) shall be considered; the classification and packing group shall then be determined in accordance with the table of precedence of hazards in 2.1.3.10.

2.2.3.1.4 Liquid or viscous mixtures and preparations, including those containing no more than 20% nitrocellulose with a nitrogen content not exceeding 12.6% (by dry mass), shall be assigned to packing group III only if the following requirements are met:

- (a) the height of the separated layer of solvent is less than 3% of the total height of the sample in the solvent-separation test (see Manual of Tests and Criteria, Part III, sub-section 32.5.1); and
- (b) the viscosity² and flash-point are in accordance with the following table:

Kinematic viscosity (extrapolated) ν (at near-zero shear rate) mm ² /s at 23 °C	Flow time t in accordance with ISO 2431:1993		Flash-point in °C
	in s	Jet diameter in mm	
20 < ν ≤ 80	20 < t ≤ 60	4	above 17
80 < ν ≤ 135	60 < t ≤ 100	4	above 10
135 < ν ≤ 220	20 < t ≤ 32	6	above 5
220 < ν ≤ 300	32 < t ≤ 44	6	above -1
300 < ν ≤ 700	44 < t ≤ 100	6	above -5
700 < ν	100 < t	6	-5 and below

² *Viscosity determination: Where the substance concerned is non-Newtonian, or where a flow cup method of viscosity determination is otherwise unsuitable, a variable shear-rate viscometer shall be used to determine the dynamic viscosity coefficient of the substance, at 23 °C, at a number of shear rates. The values obtained are plotted against shear rate and then extrapolated to zero shear rate. The dynamic viscosity thus obtained, divided by the density, gives the apparent kinematic viscosity at near-zero shear rate.*

NOTE: *Mixtures containing more than 20% but not more than 55% nitrocellulose with a nitrogen content not exceeding 12.6% by dry mass are substances assigned to UN No. 2059.*

Mixtures having a flash-point below 23 °C and containing:

- *more than 55% nitrocellulose, whatever their nitrogen content; or*
- *not more than 55% nitrocellulose with a nitrogen content above 12.6% by dry mass,*

are substances of Class 1 (UN Nos. 0340 or 0342) or of Class 4.1 (UN Nos. 2555, 2556 or 2557).

2.2.3.1.5 Non-toxic, non-corrosive and non-environmentally hazardous solutions and homogeneous mixtures having a flash-point of 23 °C or above (viscous substances, such as paints or varnishes, excluding substances containing more than 20% nitrocellulose) packed in receptacles of less than 450 litres capacity, are not subject to ADR if, in the solvent-separation test (see Manual of Tests and Criteria, Part III, sub-section 32.5.1), the height of the separated layer of solvent is less than 3% of the total height, and if the substances at 23 °C have, in the flow cup conforming to ISO 2431:1993 having a jet 6 mm in diameter, a flow time of:

- (a) not less than 60 seconds; or
- (b) not less than 40 seconds and contain not more than 60% of substances of Class 3.

2.2.3.1.6 If substances of Class 3, as a result of admixtures, come into categories of risk different from those to which the substances mentioned by name in Table A of Chapter 3.2 belong, these mixtures or solutions shall be assigned to the entries to which they belong on the basis of their actual degree of danger.

NOTE: *For the classification of solutions and mixtures (such as preparations and wastes) see also 2.1.3.*

2.2.3.1.7 On the basis of the test procedures in accordance with 2.3.3.1 and 2.3.4, and the criteria set out in 2.2.3.1.1, it may also be determined whether the nature of a solution or a mixture mentioned by name or containing a substance mentioned by name is such that the solution or mixture is not subject to the provisions for this Class (see also 2.1.3).

2.2.3.2 Substances not accepted for carriage

2.2.3.2.1 Substances of Class 3 which are liable to form peroxides easily (as happens with ethers or with certain heterocyclic oxygenated substances) shall not be accepted for carriage if their peroxide content, calculated as hydrogen peroxide (H₂O₂), exceeds 0.3%. The peroxide content shall be determined as indicated in 2.3.3.3.

2.2.3.2.2 The chemically unstable substances of Class 3 shall not be accepted for carriage unless the necessary steps have been taken to prevent their dangerous decomposition or polymerization during carriage. To this end, it shall be ensured in particular that receptacles and tanks do not contain any substance liable to promote these reactions.

2.2.3.2.3 Liquid desensitized explosives other than those listed in Table A of Chapter 3.2 shall not be accepted for carriage as substances of Class 3.

2.2.3.3 *List of collective entries*

Flammable liquids	F1	1133 ADHESIVES containing flammable liquid
		1136 COAL TAR DISTILLATES, FLAMMABLE
Without subsidiary risk	F	1139 COATING SOLUTION (includes surface treatments or coatings used for industrial or other purposes such as vehicle undercoating, drum or barrel lining)
		1169 EXTRACTS, AROMATIC, LIQUID
F	F2 elevated temperature	1197 EXTRACTS, FLAVOURING, LIQUID
		1210 PRINTING INK, flammable or
F	F2 elevated temperature	1210 PRINTING INK RELATED MATERIAL (including printing ink thinning or reducing compound), flammable
		1263 PAINT (including paint, lacquer, enamel, stain, shellac, varnish, polish, liquid filler and liquid lacquer base) or
F	F2 elevated temperature	1263 PAINT RELATED MATERIAL (including paint thinning or reducing compound)
		1266 PERFUMERY PRODUCTS with flammable solvents
F	F2 elevated temperature	1293 TINCTURES, MEDICINAL
		1306 WOOD PRESERVATIVES, LIQUID
F	F2 elevated temperature	1866 RESIN SOLUTION, flammable
		1999 TARS, LIQUID, including road oils, and cutback bitumens
F	F2 elevated temperature	3065 ALCOHOLIC BEVERAGES
		3269 POLYESTER RESIN KITS
F	F2 elevated temperature	1224 KETONES, LIQUID, N.O.S.
		1268 PETROLEUM DISTILLATES, N.O.S. or
F	F2 elevated temperature	1268 PETROLEUM PRODUCTS, N.O.S.
		1987 ALCOHOLS, N.O.S.
F	F2 elevated temperature	1989 ALDEHYDES, N.O.S.
		2319 TERPENE HYDROCARBONS, N.O.S.
F	F2 elevated temperature	3271 ETHERS, N.O.S.
		3272 ESTERS, N.O.S.
F	F2 elevated temperature	3295 HYDROCARBONS, LIQUID, N.O.S.
		3336 MERCAPTANS, LIQUID, FLAMMABLE, N.O.S. or
F	F2 elevated temperature	3336 MERCAPTANS MIXTURE, LIQUID, FLAMMABLE, N.O.S.
		1993 FLAMMABLE LIQUID, N.O.S.
F	F2 elevated temperature	3256 ELEVATED TEMPERATURE LIQUID, FLAMMABLE, N.O.S., with flash-point above 60 °C, at or above its flash-point

(cont'd on next page)

2.2.3.3 List of collective entries (cont'd)

Toxic FT	FT1	1228 MERCAPTANS, LIQUID, FLAMMABLE, TOXIC, N.O.S. or 1228 MERCAPTAN MIXTURE, LIQUID, FLAMMABLE, TOXIC, N.O.S. 1986 ALCOHOLS, FLAMMABLE, TOXIC, N.O.S. 1988 ALDEHYDES, FLAMMABLE, TOXIC, N.O.S. 2478 ISOCYANATES, FLAMMABLE, TOXIC, N.O.S. or 2478 ISOCYANATE SOLUTION, FLAMMABLE, TOXIC, N.O.S. 3248 MEDICINE, LIQUID, FLAMMABLE, TOXIC, N.O.S. 3273 NITRILES, FLAMMABLE, TOXIC, N.O.S. 1992 FLAMMABLE LIQUID, TOXIC, N.O.S.
	FT2 pesticide (f.p.<23 °C)	2758 CARBAMATE PESTICIDE, LIQUID, FLAMMABLE, TOXIC 2760 ARSENICAL PESTICIDE, LIQUID, FLAMMABLE, TOXIC 2762 ORGANOCHLORINE PESTICIDE, LIQUID, FLAMMABLE, TOXIC 2764 TRIAZINE PESTICIDE, LIQUID, FLAMMABLE, TOXIC 2772 THIOCARBAMATE PESTICIDE, LIQUID, FLAMMABLE, TOXIC 2776 COPPER BASED PESTICIDE, LIQUID, FLAMMABLE, TOXIC 2778 MERCURY BASED PESTICIDE, LIQUID, FLAMMABLE, TOXIC 2780 SUBSTITUTED NITROPHENOL PESTICIDE, LIQUID, FLAMMABLE, TOXIC 2782 BIPYRIDILIUM PESTICIDE, LIQUID, FLAMMABLE, TOXIC 2784 ORGANOPHOSPHORUS PESTICIDE, LIQUID, FLAMMABLE, TOXIC 2787 ORGANOTIN PESTICIDE, LIQUID, FLAMMABLE, TOXIC 3024 COUMARIN DERIVATIVE PESTICIDE, LIQUID, FLAMMABLE, TOXIC 3346 PHENOXYACETIC ACID DERIVATIVE PESTICIDE, LIQUID, FLAMMABLE, TOXIC 3350 PYRETHROID PESTICIDE, LIQUID, FLAMMABLE TOXIC 3021 PESTICIDE, LIQUID, FLAMMABLE, TOXIC, N.O.S. <i>NOTE: The classification of a pesticide under an entry shall be effected on the basis of the active ingredient, of the physical state of the pesticide and any subsidiary risks it may exhibit.</i>
Corrosive	FC	3469 PAINT, FLAMMABLE, CORROSIVE (including paint, lacquer, enamel, stain, shellac, varnish, polish, liquid filler and liquid lacquer base) or 3469 PAINT RELATED MATERIAL, FLAMMABLE, CORROSIVE (including paint thinning or reducing compound) 2733 AMINES, FLAMMABLE, CORROSIVE, N.O.S. or 2733 POLYAMINES, FLAMMABLE, CORROSIVE, N.O.S. 2985 CHLOROSILANES, FLAMMABLE, CORROSIVE, N.O.S. 3274 ALCOHOLATES SOLUTION, N.O.S., in alcohol 2924 FLAMMABLE LIQUID, CORROSIVE, N.O.S.
Toxic, corrosive	FTC	3286 FLAMMABLE LIQUID, TOXIC, CORROSIVE, N.O.S.
Liquid desensitised explosive	D	3343 NITROGLYCERIN MIXTURE, DESENSITIZED, LIQUID, FLAMMABLE, N.O.S. with not more than 30% nitroglycerin by mass 3357 NITROGLYCERIN MIXTURE, DESENSITIZED, LIQUID, N.O.S. with not more than 30% nitroglycerin by mass 3379 DESENSITIZED EXPLOSIVE, LIQUID, N.O.S.

2.2.41 Class 4.1 Flammable solids, self-reactive substances and solid desensitized explosives

2.2.41.1 Criteria

2.2.41.1.1 The heading of Class 4.1 covers flammable substances and articles, desensitized explosives which are solids according to subparagraph (a) of the definition "solid" in 1.2.1 and self-reactive liquids or solids.

The following are assigned to Class 4.1:

- readily flammable solid substances and articles (see paragraphs 2.2.41.1.3 to 2.2.41.1.8);
- self-reactive solids or liquids (see paragraphs 2.2.41.1.9 to 2.2.41.1.17);
- solid desensitized explosives (see 2.2.41.1.18);
- substances related to self-reactive substances (see 2.2.41.1.19).

2.2.41.1.2 The substances and articles of Class 4.1 are subdivided as follows:

F Flammable solids, without subsidiary risk:

- F1 Organic;
- F2 Organic, molten;
- F3 Inorganic;

FO Flammable solids, oxidizing;

FT Flammable solids, toxic:

- FT1 Organic, toxic;
- FT2 Inorganic, toxic;

FC Flammable solids, corrosive:

- FC1 Organic, corrosive;
- FC2 Inorganic, corrosive;

D Solid desensitized explosives without subsidiary risk;

DT Solid desensitized explosives, toxic;

SR Self-reactive substances:

- SR1 Not requiring temperature control;
- SR2 Requiring temperature control.

Flammable solids

Definition and properties

- 2.2.41.1.3 *Flammable solids* are readily combustible solids and solids which may cause fire through friction.

Readily combustible solids are powdered, granular, or pasty substances which are dangerous if they can be easily ignited by brief contact with an ignition source, such as a burning match, and if the flame spreads rapidly. The danger may come not only from the fire but also from toxic combustion products. Metal powders are especially dangerous because of the difficulty of extinguishing a fire since normal extinguishing agents such as carbon dioxide or water can increase the hazard.

Classification

- 2.2.41.1.4 Substances and articles classified as flammable solids of Class 4.1 are listed in Table A of Chapter 3.2. The assignment of organic substances and articles not mentioned by name in Table A of Chapter 3.2 to the relevant entry of sub-section 2.2.41.3 in accordance with the provisions of Chapter 2.1 can be based on experience or on the results of the test procedures in accordance with Part III, sub-section 33.2.1 of the Manual of Tests and Criteria. The assignment of inorganic substances not mentioned by name shall be based on the results of the test procedures in accordance with Part III, sub-section 33.2.1 of the Manual of Tests and Criteria; experience shall also be taken into account when it leads to a more stringent assignment.

- 2.2.41.1.5 When substances not mentioned by name are assigned to one of the entries listed in 2.2.41.3 on the basis of the test procedures in accordance with the Manual of Tests and Criteria, Part III, sub-section 33.2.1, the following criteria apply:

- (a) With the exception of metal powders or powders of metal alloys, powdery, granular or pasty substances shall be classified as readily flammable substances of Class 4.1 if they can be easily ignited by brief contact with an ignition source (e.g. a burning match), or if, in the event of ignition, the flame spreads rapidly, the burning time is less than 45 seconds for a measured distance of 100 mm or the rate of burning is greater than 2.2 mm/s;
- (b) Metal powders or powders of metal alloys shall be assigned to Class 4.1 if they can be ignited by a flame and the reaction spreads over the whole length of the sample in 10 minutes or less.

Solids which may cause fire through friction shall be classified in Class 4.1 by analogy with existing entries (e.g. matches) or in accordance with any appropriate special provision.

- 2.2.41.1.6 On the basis of the test procedure in accordance with the Manual of Tests and Criteria, Part III, Section 33.2.1 and the criteria set out in 2.2.41.1.4 and 2.2.41.1.5, it may also be determined whether the nature of a substance mentioned by name is such that the substance is not subject to the provisions for this Class.

- 2.2.41.1.7 If substances of Class 4.1, as a result of admixtures, come into different categories of risk from those to which the substances mentioned by name in Table A of Chapter 3.2 belong, these mixtures shall be assigned to the entries to which they belong on the basis of their actual degree of danger.

NOTE: For the classification of solutions and mixtures (such as preparations and wastes), see also 2.1.3.

Assignment of packing groups

2.2.41.1.8 Flammable solids classified under the various entries in Table A of Chapter 3.2 shall be assigned to packing groups II or III on the basis of test procedures of the Manual of Tests and Criteria, Part III, sub-section 33.2.1, in accordance with the following criteria:

- (a) Readily flammable solids which, when tested, have a burning time of less than 45 seconds over a measured distance of 100 mm shall be assigned to:

Packing group II: if the flame passes the wetted zone;

Packing group III: if the wetted zone stops the flame for at least four minutes;

- (b) Metal powders or powders of metal alloys shall be assigned to:

Packing group II: if, when tested, the reaction spreads over the whole length of the sample in five minutes or less;

Packing group III: if, when tested, the reaction spreads over the whole length of the sample in more than five minutes.

For solids which may cause fire through friction, the packing group shall be assigned by analogy with existing entries or in accordance with any special provision.

Self-reactive substances

Definitions

2.2.41.1.9 For the purposes of ADR, *self-reactive substances* are thermally unstable substances liable to undergo a strongly exothermic decomposition even without participation of oxygen (air). Substances are not considered to be self-reactive substances of Class 4.1, if:

- (a) they are explosives according to the criteria of Class 1;
- (b) they are oxidizing substances according to the classification procedure for Class 5.1 (see 2.2.51.1) except that mixtures of oxidizing substances which contain 5% or more of combustible organic substances shall be subjected to the classification procedure defined in Note 2;
- (c) they are organic peroxides according to the criteria of Class 5.2 (see 2.2.52.1);
- (d) their heat of decomposition is less than 300 J/g; or
- (e) their self-accelerating decomposition temperature (SADT) (see Note 3 below) is greater than 75 °C for a 50 kg package.

NOTE 1: *The heat of decomposition can be determined using any internationally recognised method e.g. differential scanning calorimetry and adiabatic calorimetry.*

NOTE 2: *Mixtures of oxidizing substances meeting the criteria of Class 5.1 which contain 5% or more of combustible organic substances, which do not meet the criteria mentioned in (a), (c), (d) or (e) above, shall be subjected to the self-reactive substance classification procedure.*

A mixture showing the properties of a self-reactive substance, type B to F, shall be classified as a self-reactive substance of Class 4.1.

A mixture showing the properties of a self-reactive substance, type G, according to the principle given in sub-section 20.4.3 (g) of Part II of the Manual of Tests and Criteria shall be considered for classification as a substance of Class 5.1 (see 2.2.51.1).

NOTE 3: *The self-accelerating decomposition temperature (SADT) is the lowest temperature at which self-accelerating decomposition may occur with a substance in the packaging as used during carriage. Requirements for the determination of the SADT are given in the Manual of Tests and Criteria, Part II, Chapter 20 and section 28.4.*

NOTE 4: *Any substance which shows the properties of a self-reactive substance shall be classified as such, even if this substance gives a positive test result according to 2.2.42.1.5 for inclusion in Class 4.2.*

Properties

- 2.2.41.1.10 The decomposition of self-reactive substances can be initiated by heat, contact with catalytic impurities (e.g. acids, heavy-metal compounds, bases), friction or impact. The rate of decomposition increases with temperature and varies with the substance. Decomposition, particularly if no ignition occurs, may result in the evolution of toxic gases or vapours. For certain self-reactive substances, the temperature shall be controlled. Some self-reactive substances may decompose explosively, particularly if confined. This characteristic may be modified by the addition of diluents or by the use of appropriate packagings. Certain self-reactive substances burn vigorously. Self-reactive substances are, for example, some compounds of the types listed below:

aliphatic azo compounds (-C-N=N-C-);
organic azides (-C-N₃);
diazonium salts (-CN₂⁺ Z⁻);
N-nitroso compounds (-N-N=O); and
aromatic sulphohydrazides (-SO₂-NH-NH₂).

This list is not exhaustive and substances with other reactive groups and some mixtures of substances may have similar properties.

Classification

- 2.2.41.1.11 Self-reactive substances are classified into seven types according to the degree of danger they present. The types of self-reactive substances range from type A, which is not accepted for carriage in the packaging in which it is tested, to type G, which is not subject to the provisions for self-reactive substances of Class 4.1. The classification of types B to F is directly related to the maximum quantity allowed in one packaging. The principles to be applied for classification as well as the applicable classification procedures, test methods and criteria and an example of a suitable test report are given in Part II of the Manual of Tests and Criteria.
- 2.2.41.1.12 Self-reactive substances which have already been classified and are already permitted for carriage in packagings are listed in 2.2.41.4, those already permitted for carriage in IBCs are listed in 4.1.4.2, packing instruction IBC520 and those already permitted for carriage in tanks according to Chapter 4.2 are listed in 4.2.5.2, portable tank instruction T23. Each permitted substance listed is assigned to a generic entry of Table A of Chapter 3.2 (UN Nos. 3221 to 3240), and appropriate subsidiary risks and remarks providing relevant transport information are given.

The collective entries specify:

- self-reactive substances types B to F, see 2.2.41.1.11 above;

- physical state (liquid/solid); and
- temperature control (when required), see 2.2.41.1.17 below.

The classification of the self-reactive substances listed in 2.2.41.4 is based on the technically pure substance (except where a concentration of less than 100% is specified).

- 2.2.41.1.13 Classification of self-reactive substances not listed in 2.2.41.4, 4.1.4.2, packing instruction IBC520 or 4.2.5.2, portable tank instruction T23 and assignment to a collective entry shall be made by the competent authority of the country of origin on the basis of a test report. The statement of approval shall contain the classification and the relevant conditions of carriage. If the country of origin is not a Contracting Party to ADR, the classification and the conditions of carriage shall be recognized by the competent authority of the first country Contracting Party to ADR reached by the consignment.
- 2.2.41.1.14 Activators, such as zinc compounds, may be added to some self-reactive substances to change their reactivity. Depending on both the type and the concentration of the activator, this may result in a decrease in thermal stability and a change in explosive properties. If either of these properties is altered, the new formulation shall be assessed in accordance with the classification procedure.
- 2.2.41.1.15 Samples of self-reactive substances or formulations of self-reactive substances not listed in 2.2.41.4, for which a complete set of test results is not available and which are to be carried for further testing or evaluation, shall be assigned to one of the appropriate entries for self-reactive substances type C provided the following conditions are met:
- the available data indicate that the sample would be no more dangerous than self-reactive substances type B;
 - the sample is packaged in accordance with packing method OP2 and the quantity per transport unit is limited to 10 kg;
 - the available data indicate that the control temperature, if any, is sufficiently low to prevent any dangerous decomposition and sufficiently high to prevent any dangerous phase separation.

Desensitization

- 2.2.41.1.16 In order to ensure safety during carriage, self-reactive substances are in many cases desensitized by use of a diluent. Where a percentage of a substance is stipulated, this refers to the percentage by mass, rounded to the nearest whole number. If a diluent is used, the self-reactive substance shall be tested with the diluent present in the concentration and form used in carriage. Diluents which may allow a self-reactive substance to concentrate to a dangerous extent in the event of leakage from a packaging shall not be used. Any diluent shall be compatible with the self-reactive substance. In this regard, compatible diluents are those solids or liquids which have no detrimental influence on the thermal stability and hazard type of the self-reactive substance. Liquid diluents in formulations requiring temperature control (see 2.2.41.1.14) shall have a boiling point of at least 60 °C and a flash-point not less than 5 °C. The boiling point of the liquid shall be at least 50 °C higher than the control temperature of the self-reactive substance.

Temperature control requirements

- 2.2.41.1.17 Certain self-reactive substances may only be carried under temperature controlled conditions. The control temperature is the maximum temperature at which the self-reactive substance can be safely carried. It is assumed that the temperature of the immediate

surroundings of a package only exceeds 55 °C during carriage for a relatively short time in a 24 hour period. In the event of loss of temperature control, it may be necessary to implement emergency procedures. The emergency temperature is the temperature at which such procedures shall be implemented.

The control and emergency temperatures are derived from the SADT (see table 1). The SADT shall be determined in order to decide whether a substance shall be subjected to temperature control during carriage. Provisions for the determination of the SADT are given in the Manual of Tests and Criteria, Part II, Chapter 20 and Section 28.4.

Table 1: Derivation of control and emergency temperatures

Type of receptacle	SADT ^a	Control temperature	Emergency temperature
Single packagings and IBCs	20 °C or less	20 °C below SADT	10 °C below SADT
	over 20 °C to 35 °C	15 °C below SADT	10 °C below SADT
	over 35 °C	10 °C below SADT	5 °C below SADT
Tanks	not greater than 50 °C	10 °C below SADT	5 °C below SADT

^a *SADT of the substance as packaged for carriage.*

Self-reactive substances with an SADT not greater than 55 °C shall be subject to temperature control during carriage. Where applicable, control and emergency temperatures are listed in 2.2.41.4. The actual temperature during carriage may be lower than the control temperature but shall be selected so as to avoid dangerous separation of phases.

Solid desensitized explosives

- 2.2.41.1.18 Solid desensitized explosives are substances which are wetted with water or alcohols or are diluted with other substances to suppress their explosive properties. Such entries in Table A of Chapter 3.2 are: UN Nos. 1310, 1320, 1321, 1322, 1336, 1337, 1344, 1347, 1348, 1349, 1354, 1355, 1356, 1357, 1517, 1571, 2555, 2556, 2557, 2852, 2907, 3317, 3319, 3344, 3364, 3365, 3366, 3367, 3368, 3369, 3370, 3376, 3380 and 3474.

Substances related to self-reactive substances

- 2.2.41.1.19 Substances that:
- have been provisionally accepted into Class 1 according to Test Series 1 and 2 but exempted from Class 1 by Test Series 6;
 - are not self-reactive substances of Class 4.1; and
 - are not substances of Classes 5.1 or 5.2;

are also assigned to Class 4.1. UN Nos. 2956, 3241, 3242 and 3251 are such entries.

2.2.41.2 *Substances not accepted for carriage*

- 2.2.41.2.1 The chemically unstable substances of Class 4.1 shall not be accepted for carriage unless the necessary steps have been taken to prevent their dangerous decomposition or polymerization during carriage. To this end, it shall in particular be ensured that receptacles and tanks do not contain any substance liable to promote these reactions.

- 2.2.41.2.2 Flammable solids, oxidizing, assigned to UN No. 3097 shall not be accepted for carriage unless they meet the requirements for Class 1 (see also 2.1.3.7).
- 2.2.41.2.3 The following substances shall not be accepted for carriage:
- Self-reactive substances of type A (see Manual of Tests and Criteria, Part II, paragraph 20.4.2 (a));
 - Phosphorus sulphides which are not free from yellow and white phosphorus;
 - Solid sensitized explosives other than those listed in Table A of Chapter 3.2;
 - Inorganic flammable substances in the molten form other than UN No. 2448 SULPHUR, MOLTEN.

2.2.41.3 *List of collective entries*

Flammable solids	without subsidiary risk	organic	F1	3175 SOLIDS CONTAINING FLAMMABLE LIQUID, N.O.S. 1353 FIBRES IMPREGNATED WITH WEAKLY NITRATED NITROCELLULOSE, N.O.S. or 1353 FABRICS IMPREGNATED WITH WEAKLY NITRATED NITROCELLULOSE, N.O.S. 1325 FLAMMABLE SOLID, ORGANIC, N.O.S.																																								
		organic molten	F2	3176 FLAMMABLE SOLID, ORGANIC, MOLTEN, N.O.S.																																								
		inorganic	F3	3089 METAL POWDER, FLAMMABLE, N.O.S. ^{a b} 3181 METAL SALTS OF ORGANIC COMPOUNDS, FLAMMABLE, N.O.S. 3182 METAL HYDRIDES, FLAMMABLE, N.O.S. ^c 3178 FLAMMABLE SOLID, INORGANIC, N.O.S.																																								
		oxidizing	FO	3097 FLAMMABLE SOLID, OXIDIZING, N.O.S. (not allowed, see para. 2.2.41.2.2)																																								
Solid desensitized explosives	toxic FT	organic	FT1	2926 FLAMMABLE SOLID, TOXIC, ORGANIC, N.O.S.																																								
		inorganic	FT2	3179 FLAMMABLE SOLID, TOXIC, INORGANIC, N.O.S.																																								
	corrosive FC	organic	FC1	2925 FLAMMABLE SOLID, CORROSIVE, ORGANIC, N.O.S.																																								
		inorganic	FC2	3180 FLAMMABLE SOLID, CORROSIVE, INORGANIC, N.O.S.																																								
	without subsidiary risk		D	3319 NITROGLYCERIN MIXTURE, DESENSITIZED, SOLID, N.O.S. with more than 2% but not more than 10% nitroglycerin by mass 3344 PENTAERYTHRITOL TETRANITRATE (PENTAERYTHRITOL TETRANITRATE, PETN) MIXTURE, DESENSITIZED, SOLID, N.O.S. with more than 10% but not more than 20% PETN by mass 3380 DESENSITIZED EXPLOSIVE, SOLID, N.O.S.																																								
	toxic		DT	Only substances listed in Table A of Chapter 3.2 are to be accepted for carriage as substances of Class 4.1																																								
Self-reactive substances SR	not requiring temperature control		SR1	<table border="0"> <tbody> <tr> <td>3221 SELF-REACTIVE LIQUID TYPE B</td> <td rowspan="2">}</td> <td rowspan="2">Not accepted for carriage, see 2.2.41.2.3</td> </tr> <tr> <td>3222 SELF-REACTIVE SOLID TYPE B</td> </tr> <tr> <td>3223 SELF-REACTIVE LIQUID TYPE C</td> <td rowspan="2">}</td> <td rowspan="2">Not subject to the provisions applicable to Class 4.1, see 2.2.41.1.11</td> </tr> <tr> <td>3224 SELF-REACTIVE SOLID TYPE C</td> </tr> <tr> <td>3225 SELF-REACTIVE LIQUID TYPE D</td> <td rowspan="2">}</td> <td rowspan="2"></td> </tr> <tr> <td>3226 SELF-REACTIVE SOLID TYPE D</td> </tr> <tr> <td>3227 SELF-REACTIVE LIQUID TYPE E</td> <td rowspan="2">}</td> <td rowspan="2"></td> </tr> <tr> <td>3228 SELF-REACTIVE SOLID TYPE E</td> </tr> <tr> <td>3229 SELF-REACTIVE LIQUID TYPE F</td> <td rowspan="2">}</td> <td rowspan="2"></td> </tr> <tr> <td>3230 SELF-REACTIVE SOLID TYPE F</td> </tr> <tr> <td>3221 SELF-REACTIVE LIQUID TYPE A</td> <td rowspan="2">}</td> <td rowspan="2"></td> </tr> <tr> <td>3222 SELF-REACTIVE SOLID TYPE A</td> </tr> <tr> <td>3223 SELF-REACTIVE LIQUID TYPE C</td> <td rowspan="2">}</td> <td rowspan="2"></td> </tr> <tr> <td>3224 SELF-REACTIVE SOLID TYPE C</td> </tr> <tr> <td>3225 SELF-REACTIVE LIQUID TYPE D</td> <td rowspan="2">}</td> <td rowspan="2"></td> </tr> <tr> <td>3226 SELF-REACTIVE SOLID TYPE D</td> </tr> <tr> <td>3227 SELF-REACTIVE LIQUID TYPE E</td> <td rowspan="2">}</td> <td rowspan="2"></td> </tr> <tr> <td>3228 SELF-REACTIVE SOLID TYPE E</td> </tr> <tr> <td>3229 SELF-REACTIVE LIQUID TYPE F</td> <td rowspan="2">}</td> <td rowspan="2"></td> </tr> <tr> <td>3230 SELF-REACTIVE SOLID TYPE F</td> </tr> </tbody> </table>	3221 SELF-REACTIVE LIQUID TYPE B	}	Not accepted for carriage, see 2.2.41.2.3	3222 SELF-REACTIVE SOLID TYPE B	3223 SELF-REACTIVE LIQUID TYPE C	}	Not subject to the provisions applicable to Class 4.1, see 2.2.41.1.11	3224 SELF-REACTIVE SOLID TYPE C	3225 SELF-REACTIVE LIQUID TYPE D	}		3226 SELF-REACTIVE SOLID TYPE D	3227 SELF-REACTIVE LIQUID TYPE E	}		3228 SELF-REACTIVE SOLID TYPE E	3229 SELF-REACTIVE LIQUID TYPE F	}		3230 SELF-REACTIVE SOLID TYPE F	3221 SELF-REACTIVE LIQUID TYPE A	}		3222 SELF-REACTIVE SOLID TYPE A	3223 SELF-REACTIVE LIQUID TYPE C	}		3224 SELF-REACTIVE SOLID TYPE C	3225 SELF-REACTIVE LIQUID TYPE D	}		3226 SELF-REACTIVE SOLID TYPE D	3227 SELF-REACTIVE LIQUID TYPE E	}		3228 SELF-REACTIVE SOLID TYPE E	3229 SELF-REACTIVE LIQUID TYPE F	}		3230 SELF-REACTIVE SOLID TYPE F
	3221 SELF-REACTIVE LIQUID TYPE B	}	Not accepted for carriage, see 2.2.41.2.3																																									
3222 SELF-REACTIVE SOLID TYPE B																																												
3223 SELF-REACTIVE LIQUID TYPE C	}	Not subject to the provisions applicable to Class 4.1, see 2.2.41.1.11																																										
3224 SELF-REACTIVE SOLID TYPE C																																												
3225 SELF-REACTIVE LIQUID TYPE D	}																																											
3226 SELF-REACTIVE SOLID TYPE D																																												
3227 SELF-REACTIVE LIQUID TYPE E	}																																											
3228 SELF-REACTIVE SOLID TYPE E																																												
3229 SELF-REACTIVE LIQUID TYPE F	}																																											
3230 SELF-REACTIVE SOLID TYPE F																																												
3221 SELF-REACTIVE LIQUID TYPE A	}																																											
3222 SELF-REACTIVE SOLID TYPE A																																												
3223 SELF-REACTIVE LIQUID TYPE C	}																																											
3224 SELF-REACTIVE SOLID TYPE C																																												
3225 SELF-REACTIVE LIQUID TYPE D	}																																											
3226 SELF-REACTIVE SOLID TYPE D																																												
3227 SELF-REACTIVE LIQUID TYPE E	}																																											
3228 SELF-REACTIVE SOLID TYPE E																																												
3229 SELF-REACTIVE LIQUID TYPE F	}																																											
3230 SELF-REACTIVE SOLID TYPE F																																												
requiring temperature control		SR2	3231 SELF-REACTIVE LIQUID TYPE B, TEMPERATURE CONTROLLED 3232 SELF-REACTIVE SOLID TYPE B, TEMPERATURE CONTROLLED 3233 SELF-REACTIVE LIQUID TYPE C, TEMPERATURE CONTROLLED 3234 SELF-REACTIVE SOLID TYPE C, TEMPERATURE CONTROLLED 3235 SELF-REACTIVE LIQUID TYPE D, TEMPERATURE CONTROLLED 3236 SELF-REACTIVE SOLID TYPE D, TEMPERATURE CONTROLLED 3237 SELF-REACTIVE LIQUID TYPE E, TEMPERATURE CONTROLLED 3238 SELF-REACTIVE SOLID TYPE E, TEMPERATURE CONTROLLED 3239 SELF-REACTIVE LIQUID TYPE F, TEMPERATURE CONTROLLED 3240 SELF-REACTIVE SOLID TYPE F, TEMPERATURE CONTROLLED																																									

^a Metals and metal alloys in powdered or other flammable form, liable to spontaneous combustion, are substances of Class 4.2.

^b Metals and metal alloys in powdered or other flammable form, which in contact with water, emit flammable gases, are substances of Class 4.3.

^c Metals hydrides which, in contact with water, emit flammable gases, are substances of Class 4.3. Aluminium borohydride or aluminium borohydride in devices are substances of Class 4.2, UN No. 2870.

2.2.41.4 *List of currently assigned self-reactive substances in packagings*

In the column "Packing Method" codes "OP1" to "OP8" refer to packing methods in 4.1.4.1, packing instruction P520 (see also 4.1.7.1). Self-reactive substances to be carried shall fulfil the classification and the control and emergency temperatures (derived from the SADT) as listed. For substances permitted in IBCs, see 4.1.4.2, packing instruction IBC520 and, for those permitted in tanks according to Chapter 4.2, see 4.2.5.2, portable tank instruction T23.

NOTE: The classification given in this table is based on the technically pure substance (except where a concentration of less than 100% is specified). For other concentrations, the substance may be classified differently following the procedures given in Part II of the Manual of Tests and Criteria and in 2.2.41.1.17.

SELF-REACTIVE SUBSTANCE	Concentration (%)	Packing method	Control temperature (°C)	Emergency temperature (°C)	UN generic entry	Remarks
ACETONE-PYROGALLOL COPOLYMER 2-DIAZO-1-NAPHTHOL-5-SULPHONATE	100	OP8			3228	
AZODICARBONAMIDE FORMULATION TYPE B, TEMPERATURE CONTROLLED	< 100	OP5			3232	(1) (2)
AZODICARBONAMIDE FORMULATION TYPE C	< 100	OP6			3224	(3)
AZODICARBONAMIDE FORMULATION TYPE C, TEMPERATURE CONTROLLED	< 100	OP6			3234	(4)
AZODICARBONAMIDE FORMULATION TYPE D	< 100	OP7			3226	(5)
AZODICARBONAMIDE FORMULATION TYPE D, TEMPERATURE CONTROLLED	< 100	OP7			3236	(6)
2,2' -AZODI(2,4-DIMETHYL- 4-METHOXY- VALERONITRILE)	100	OP7	-5	+5	3236	
2,2' -AZODI(2,4-DIMETHYL- VALERONITRILE)	100	OP7	+10	+15	3236	
2,2' -AZODI(ETHYL- 2-METHYL-PROPIONATE)	100	OP7	+20	+25	3235	
1,1-AZODI(HEXAHYDROBENZONITRILE)	100	OP7			3226	
2,2' -AZODI(ISOBUTYRONITRILE	100	OP6	+40	+45	3234	
2,2' -AZODI(ISOBUTYRONITRILE) as a water based paste	≤ 50%	OP6			3224	
2,2' -AZODI(2-METHYLBUTYRONITRILE)	100	OP7	+35	+40	3236	
BENZENE-1,3-DISULPHONYL HYDRAZIDE, as a paste	52	OP7			3226	
BENZENE SULPHONYL HYDRAZIDE	100	OP7			3226	
4-(BENZYL(ETHYL)AMINO)-3-ETHOXY- BENZENEDIAZONIUM ZINC CHLORIDE	100	OP7			3226	
4-(BENZYL(METHYL)AMINO)-3-ETHOXY- BENZENEDIAZONIUM ZINC CHLORIDE	100	OP7	+40	+45	3236	
3-CHLORO-4-DIETHYLAMINO BENZENE- DIAZONIUM ZINC CHLORIDE	100	OP7			3226	
2-DIAZO-1-NAPHTHOL-4-SULPHONYL CHLORIDE	100	OP5			3222	(2)
2-DIAZO-1-NAPHTHOL-5-SULPHONYL CHLORIDE	100	OP5			3222	(2)
2-DIAZO-1-NAPHTHOL SULPHONIC ACID ESTER MIXTURE, TYPE D	< 100	OP7			3226	(9)
2,5-DIBUTOXY-4-(4-MORPHOLINYL)- BENZENEDIAZONIUM, TETRACHLOROZINCATE (2:1)	100	OP8			3228	
2,5-DIETHOXY-4-MORPHOLINO- BENZENEDIAZONIUM ZINC CHLORIDE	67-100	OP7	+35	+40	3236	
2,5-DIETHOXY-4-MORPHOLINO- BENZENEDIAZONIUM ZINC CHLORIDE	66	OP7	+40	+45	3236	
2,5-DIETHOXY-4-MORPHOLINO- BENZENEDIAZONIUM TETRAFLUOROBORATE	100	OP7	+30	+35	3236	

SELF-REACTIVE SUBSTANCE	Concentration (%)	Packing method	Control temperature (°C)	Emergency temperature (°C)	UN generic entry	Remarks
2,5-DIETHOXY-4-(4-MORPHOLINYL)-BENZENEDIAZONIUM SULPHATE	100	OP7			3226	
2,5-DIETHOXY-4-(PHENYLSULPHONYL)-BENZENEDIAZONIUM ZINC CHLORIDE	67	OP7	+40	+45	3236	
DIETHYLENEGLYCOL BIS (ALLYL CARBONATE) + DI- ISOPROPYL-PEROXYDICARBONATE	≥ 88+≤ 12	OP8	-10	0	3237	
2,5-DIMETHOXY-4-(4-METHYL-PHENYLSULPHONYL)BENZENE- DIAZONIUM ZINC CHLORIDE	79	OP7	+40	+45	3236	
4-(DIMETHYLAMINO)-BENZENE-DIAZONIUM TRICHLOROZINCATE (-1)	100	OP8			3228	
4-DIMETHYLAMINO-6-(2-DIMETHYL-AMINOETHOXY) TOLUENE- 2-DIAZONIUM ZINC CHLORIDE	100	OP7	+40	+45	3236	
N,N'-DINITROSO-N,N'- DIMETHYL TEREPHTHALAMIDE, as a paste	72	OP6			3224	
N,N'-DINITROSOPENTAMETHYLENE-TETRAMINE	82	OP6			3224	(7)
DIPHENYLOXIDE-4,4'-DISULPHONYL HYDRAZIDE	100	OP7			3226	
4-DIPROPYLAMINO BENZENE- DIAZONIUM ZINC CHLORIDE	100	OP7			3226	
2-(N,N-ETHOXYCARBONYL-PHENYLAMINO)-3-METHOXY-4-(N-METHYL-N-CYCLOHEXYLAMINO) BENZENEDIAZONIUM ZINC CHLORIDE	63-92	OP7	+ 40	+ 45	3236	
2-(N,N-ETHOXYCARBONYL-PHENYLAMINO)-3-METHOXY-4-(N-METHYL-N-CYCLOHEXYLAMINO) BENZENEDIAZONIUM ZINC CHLORIDE	62	OP7	+ 35	+ 40	3236	
N-FORMYL-2-(NITROMETHYLENE) -1,3-PERHYDROTHIAZINE	100	OP7	+45	+50	3236	
2-(2-HYDROXYETHOXY)-1-(PYRROLIDIN-1-YL)BENZENE-4- DIAZONIUM ZINC CHLORIDE	100	OP7	+ 45	+ 50	3236	
3-(2-HYDROXYETHOXY)-4- (PYRROLIDIN-1-YL) BENZENE DIAZONIUM ZINC CHLORIDE	100	OP7	+40	+45	3236	
2-(N,N-METHYLAMINOETHYLCARBONYL)-4-(3,4-DIMETHYLPHENYLSULPHONYL) BENZENEDIAZONIUM HYDROGEN SULPHATE	96	OP7	+45	+50	3236	
4-METHYLBENZENESULPHONYLHYDRAZIDE	100	OP7			3226	
3-METHYL-4-(PYRROLIDIN-1-YL) BENZENEDIAZONIUM TETRAFLUOROBORATE	95	OP6	+45	+50	3234	
4-NITROSOPHENOL	100	OP7	+35	+40	3236	
SELF-REACTIVE LIQUID, SAMPLE		OP2			3223	(8)
SELF-REACTIVE LIQUID, SAMPLE, TEMPERATURE CONTROLLED		OP2			3233	(8)
SELF-REACTIVE SOLID, SAMPLE		OP2			3224	(8)
SELF-REACTIVE SOLID, SAMPLE, TEMPERATURE CONTROLLED		OP2			3234	(8)
SODIUM 2-DIAZO-1-NAPHTHOL- 4-SULPHONATE	100	OP7			3226	
SODIUM 2-DIAZO-1-NAPHTHOL- 5-SULPHONATE	100	OP7			3226	
TETRAMINE PALLADIUM (II) NITRATE	100	OP6	+30	+35	3234	

Remarks

- (1) Azodicarbonamide formulations which fulfil the criteria of paragraph 20.4.2 (b) of the Manual of Tests and Criteria. The control and emergency temperatures shall be determined by the procedure given in 2.2.41.1.17.
- (2) "EXPLOSIVE" subsidiary risk label required (Model No. 1, see 5.2.2.2.2).
- (3) Azodicarbonamide formulations which fulfil the criteria of paragraph 20.4.2 (c) of the Manual of Tests and Criteria.
- (4) Azodicarbonamide formulations which fulfil the criteria of paragraph 20.4.2 (c) of the Manual of Tests and Criteria. The control and emergency temperatures shall be determined by the procedure given in 2.2.41.1.17.
- (5) Azodicarbonamide formulations which fulfil the criteria of paragraph 20.4.2 (d) of the Manual of Tests and Criteria.
- (6) Azodicarbonamide formulations which fulfil the criteria of paragraph 20.4.2 (d) of the Manual of Tests and Criteria. The control and emergency temperatures shall be determined by the procedure given in 2.2.41.1.17.
- (7) With a compatible diluent having a boiling point of not less than 150 °C.
- (8) See 2.2.41.1.15.
- (9) This entry applies to mixtures of esters of 2-diazo-1-naphthol-4-sulphonic acid and 2-diazo-1-naphthol-5-sulphonic acid which fulfil the criteria of paragraph 20.4.2 (d) of the *Manual of Test and Criteria*.

2.2.42 Class 4.2 Substances liable to spontaneous combustion

2.2.42.1 Criteria

2.2.42.1.1 The heading of Class 4.2 covers:

- *Pyrophoric substances* which are substances, including mixtures and solutions (liquid or solid), which even in small quantities ignite on contact with air within five minutes. These are the Class 4.2 substances the most liable to spontaneous combustion; and
- *Self-heating substances and articles* which are substances and articles, including mixtures and solutions, which, on contact with air, without energy supply, are liable to self-heating. These substances will ignite only in large amounts (kilograms) and after long periods of time (hours or days).

2.2.42.1.2 The substances and articles of Class 4.2 are subdivided as follows:

S Substances liable to spontaneous combustion, without subsidiary risk:

- S1 Organic, liquid;
- S2 Organic, solid;
- S3 Inorganic, liquid;
- S4 Inorganic, solid;
- S5 Organometallic;

SW Substances liable to spontaneous combustion, which, in contact with water, emit flammable gases;

SO Substances liable to spontaneous combustion, oxidizing;

ST Substances liable to spontaneous combustion, toxic:

- ST1 Organic, toxic, liquid;
- ST2 Organic, toxic, solid;
- ST3 Inorganic, toxic, liquid;
- ST4 Inorganic, toxic, solid;

SC Substances liable to spontaneous combustion, corrosive:

- SC1 Organic, corrosive, liquid;
- SC2 Organic, corrosive, solid;
- SC3 Inorganic, corrosive, liquid;
- SC4 Inorganic, corrosive, solid.

Properties

2.2.42.1.3 Self-heating of a substance is a process where the gradual reaction of that substance with oxygen (in air) generates heat. If the rate of heat production exceeds the rate of heat loss, then the temperature of the substance will rise which, after an induction time, may lead to self-ignition and combustion.

Classification

2.2.42.1.4 Substances and articles classified in Class 4.2 are listed in Table A of Chapter 3.2. The assignment of substances and articles not mentioned by name in Table A of Chapter 3.2 to the relevant specific N.O.S. entry of 2.2.42.3 in accordance with the provisions of Chapter 2.1 can be based on experience or the results of the test procedures in accordance with the Manual of Tests and Criteria, Part III, Section 33.3. Assignment to general N.O.S. entries of Class 4.2 shall be based on the results of the test procedures in accordance with the Manual of Tests and Criteria, Part III, section 33.3; experience shall also be taken into account when it leads to a more stringent assignment.

2.2.42.1.5 When substances or articles not mentioned by name are assigned to one of the entries listed in 2.2.42.3 on the basis of the test procedures in accordance with the Manual of Tests and Criteria, Part III, section 33.3, the following criteria shall apply:

- (a) Solids liable to spontaneous combustion (pyrophoric) shall be assigned to Class 4.2 when they ignite on falling from a height of 1 m or within five minutes;
- (b) Liquids liable to spontaneous combustion (pyrophoric) shall be assigned to Class 4.2 when:
 - (i) on being poured on an inert carrier, they ignite within five minutes, or
 - (ii) in the event of a negative result of the test according to (i), when poured on a dry, indented filter paper (Whatman No. 3 filter), they ignite or carbonize it within five minutes;
- (c) Substances in which, in a 10 cm sample cube, at 140 °C test temperature, spontaneous combustion or a rise in temperature to over 200 °C is observed within 24 hours shall be assigned to Class 4.2. This criterion is based on the temperature of the spontaneous combustion of charcoal, which is at 50 °C for a sample cube of 27 m³. Substances with a temperature of spontaneous combustion higher than 50 °C for a volume of 27 m³ are not to be assigned to Class 4.2.

NOTE 1: *Substances carried in packages with a volume of not more than 3 m³ are exempted from Class 4.2 if, tested with a 10 cm sample cube at 120 °C, no spontaneous combustion nor a rise in temperature to over 180 °C is observed within 24 hours.*

NOTE 2: *Substances carried in packages with a volume of not more than 450 litres are exempted from Class 4.2 if, tested with a 10 cm sample cube at 100 °C, no spontaneous combustion nor a rise in temperature to over 160 °C is observed within 24 hours.*

NOTE 3: *Since organometallic substances can be classified in Class 4.2 or 4.3 with additional subsidiary risks, depending on their properties, a specific classification flow chart for these substances is given in 2.3.5.*

2.2.42.1.6 If substances of Class 4.2, as a result of admixtures, come into different categories of risk from those to which the substances mentioned by name in Table A of Chapter 3.2 belong, these mixtures shall be assigned to the entries to which they belong on the basis of their actual degree of danger.

NOTE: *For the classification of solutions and mixtures (such as preparations and wastes), see also 2.1.3.*

- 2.2.42.1.7 On the basis of the test procedure in the Manual of Tests and Criteria, Part III, section 33.3 and the criteria set out in 2.2.42.1.5, it may also be determined whether the nature of a substance mentioned by name is such that the substance is not subject to the provisions for this Class.

Assignment of packing groups

- 2.2.42.1.8 Substances and articles classified under the various entries in Table A of Chapter 3.2 shall be assigned to packing groups I, II or III on the basis of test procedures of the Manual of Tests and Criteria, Part III, section 33.3, in accordance with the following criteria:

- (a) Substances liable to spontaneous combustion (pyrophoric) shall be assigned to packing group I;
- (b) Self-heating substances and articles in which, in a 2.5 cm sample cube, at 140 °C test temperature, spontaneous combustion or a rise in temperature to over 200 °C is observed within 24 hours, shall be assigned to packing group II;

Substances with a temperature of spontaneous combustion higher than 50 °C for a volume of 450 litres are not to be assigned to packing group II;

- (c) Slightly self-heating substances in which, in a 2.5 cm sample cube, the phenomena referred to under (b) are not observed, in the given conditions, but in which in a 10 cm sample cube at 140 °C test temperature spontaneous combustion or a rise in temperature to over 200 °C is observed within 24 hours, shall be assigned to packing group III.

2.2.42.2 *Substances not accepted for carriage*

The following substances shall not be accepted for carriage:

- UN No. 3255 tert-BUTYL HYPOCHLORITE; and
- Self-heating solids, oxidizing, assigned to UN No. 3127 unless they meet the requirements for Class 1 (see 2.1.3.7).

2.2.42.3 *List of collective entries*

Substances liable to spontaneous combustion	organic	liquid	S1	2845 PYROPHORIC LIQUID, ORGANIC, N.O.S. 3183 SELF-HEATING LIQUID, ORGANIC, N.O.S.
		S2	1373 FIBRES or FABRICS, ANIMAL or VEGETABLE or SYNTHETIC, N.O.S. with oil 2006 PLASTICS, NITROCELLULOSE-BASED, SELF-HEATING, N.O.S. 3313 ORGANIC PIGMENTS, SELF HEATING 2846 PYROPHORIC SOLID, ORGANIC, N.O.S. 3088 SELF-HEATING SOLID, ORGANIC, N.O.S.	
Without subsidiary risk	inorganic	liquid	S3	3194 PYROPHORIC LIQUID, INORGANIC, N.O.S. 3186 SELF-HEATING LIQUID, INORGANIC, N.O.S.
S		S4	1383 PYROPHORIC METAL, N.O.S. or 1383 PYROPHORIC ALLOY, N.O.S. 1378 METAL CATALYST, WETTED with a visible excess of liquid 2881 METAL CATALYST, DRY 3189 ^a METAL POWDER, SELF-HEATING, N.O.S. 3205 ALKALINE EARTH METAL ALCOHOLATES, N.O.S. 3200 PYROPHORIC SOLID, INORGANIC, N.O.S. 3190 SELF-HEATING SOLID, INORGANIC, N.O.S.	
		S5	3392 ORGANOMETALLIC SUBSTANCE, LIQUID, PYROPHORIC 3391 ORGANOMETALLIC SUBSTANCE, SOLID, PYROPHORIC 3400 ORGANOMETALLIC SUBSTANCE, SOLID, SELF-HEATING	
Water-reactive			SW	3394 ORGANOMETALLIC SUBSTANCE, LIQUID, PYROPHORIC, WATER-REACTIVE 3393 ORGANOMETALLIC SUBSTANCE, SOLID, PYROPHORIC, WATER-REACTIVE
Oxidizing			SO	3127 SELF-HEATING SOLID, OXIDIZING, N.O.S. (not allowed, see 2.2.42.2)
Toxic	organic	liquid	ST1	3184 SELF-HEATING LIQUID, TOXIC, ORGANIC, N.O.S.
		S2	3128 SELF-HEATING SOLID, TOXIC, ORGANIC, N.O.S.	
ST	inorganic	liquid	ST3	3187 SELF-HEATING LIQUID, TOXIC, INORGANIC, N.O.S.
		S4	3191 SELF-HEATING SOLID, TOXIC, INORGANIC, N.O.S.	
Corrosive	organic	liquid	SC1	3185 SELF-HEATING LIQUID, CORROSIVE, ORGANIC, N.O.S.
		S2	3126 SELF-HEATING SOLID, CORROSIVE, ORGANIC, N.O.S.	
SC	inorganic	liquid	SC3	3188 SELF-HEATING LIQUID, CORROSIVE, INORGANIC, N.O.S.
		S4	3206 ALKALI METAL ALCOHOLATES, SELF-HEATING, CORROSIVE, N.O.S. 3192 SELF-HEATING SOLID, CORROSIVE, INORGANIC, N.O.S.	

^a Dust and powder of metals, non toxic in a non-spontaneous combustible form which nevertheless, in contact with water, emit flammable gases, are substances of Class 4.3.

2.2.43 Class 4.3 Substances which, in contact with water, emit flammable gases

2.2.43.1 Criteria

2.2.43.1.1 The heading of Class 4.3 covers substances which react with water to emit flammable gases liable to form explosive mixtures with air, and articles containing such substances.

2.2.43.1.2 Substances and articles of Class 4.3 are subdivided as follows:

W Substances which, in contact with water, emit flammable gases, without subsidiary risk, and articles containing such substances:

- W1 Liquid;
- W2 Solid;
- W3 Articles;

WF1 Substances which, in contact with water, emit flammable gases, liquid, flammable;

WF2 Substances which, in contact with water, emit flammable gases, solid, flammable;

WS Substances which, in contact with water, emit flammable gases, solid, self-heating;

WO Substances which, in contact with water, emit flammable gases, oxidizing, solid;

WT Substances which, in contact with water, emit flammable gases, toxic:

- WT1 Liquid;
- WT2 Solid;

WC Substances which, in contact with water, emit flammable gases, corrosive:

- WC1 Liquid;
- WC2 Solid;

WFC Substances which, in contact with water, emit flammable gases, flammable, corrosive.

Properties

2.2.43.1.3 Certain substances in contact with water may emit flammable gases that can form explosive mixtures with air. Such mixtures are easily ignited by all ordinary sources of ignition, for example naked lights, sparking handtools or unprotected light bulbs. The resulting blast wave and flames may endanger people and the environment. The test method referred to in 2.2.43.1.4 below is used to determine whether the reaction of a substance with water leads to the development of a dangerous amount of gases which may be flammable. This test method shall not be applied to pyrophoric substances.

Classification

2.2.43.1.4 Substances and articles classified in Class 4.3 are listed in Table A of Chapter 3.2. The assignment of substances and articles not mentioned by name in Table A of Chapter 3.2 to the relevant entry of 2.2.43.3 in accordance with the provisions of Chapter 2.1 shall be based on the results of the test procedure in accordance with the Manual of Tests and Criteria, Part III, Section 33.4; experience shall also be taken into account when it leads to a more stringent assignment.

2.2.43.1.5 When substances not mentioned by name are assigned to one of the entries listed in 2.2.43.3 on the basis of the test procedure in accordance with the Manual of Tests and Criteria, Part III, Section 33.4, the following criteria shall apply:

A substance shall be assigned to Class 4.3 if:

- (a) spontaneous ignition of the gas emitted takes place in any step of the test procedure; or
- (b) there is an evolution of flammable gas at a rate greater than 1 litre per kilogram of the substance to be tested per hour.

NOTE: *Since organometallic substances can be classified in Class 4.2 or 4.3 with additional subsidiary risks, depending on their properties, a specific classification flow chart for these substances is given in 2.3.5.*

2.2.43.1.6 If substances of Class 4.3, as a result of admixtures, come into different categories of risk from those to which the substances mentioned by name in Table A of Chapter 3.2 belong, these mixtures shall be assigned to the entries to which they belong on the basis of their actual degree of danger.

NOTE: *For the classification of solutions and mixtures (such as preparations and wastes) see also 2.1.3.*

2.2.43.1.7 On the basis of the test procedures in accordance with the Manual of Tests and Criteria, Part III, Section 33.4, and the criteria set out in paragraph 2.2.43.1.5, it may also be determined whether the nature of a substance mentioned by name is such that the substance is not subject to the provisions for this Class.

Assignment of packing groups

2.2.43.1.8 Substances and articles classified under the various entries in Table A of Chapter 3.2 shall be assigned to packing groups I, II or III on the basis of test procedures of the Manual of Tests and Criteria, Part III, section 33.4, in accordance with the following criteria:

- (a) Packing group I shall be assigned to any substance which reacts vigorously with water at ambient temperature and generally demonstrates a tendency for the gas produced to ignite spontaneously, or one which reacts readily with water at ambient temperatures such that the rate of evolution of flammable gas is equal to or greater than 10 litres per kilogram of substance over any one minute period;
- (b) Packing group II shall be assigned to any substance which reacts readily with water at ambient temperature such that the maximum rate of evolution of flammable gas is equal to or greater than 20 litres per kilogram of substance per hour, and which does not meet the criteria of packing group I;
- (c) Packing group III shall be assigned to any substance which reacts slowly with water at ambient temperature such that the maximum rate of evolution of flammable gas is greater than 1 litre per kilogram of substance per hour, and which does not meet the criteria of packing groups I or II.

2.2.43.2 Substances not accepted for carriage

Water-reactive solids, oxidizing, assigned to UN No. 3133 shall not be accepted for carriage unless they meet the requirements for Class 1 (see also 2.1.3.7).

2.2.43.3 *List of collective entries*

Substances which, in contact with water, emit flammable gases	liquid	W1	1389 ALKALI METAL AMALGAM, LIQUID 1391 ALKALI METAL DISPERSION or 1391 ALKALINE EARTH METAL DISPERSION 1392 ALKALINE EARTH METAL AMALGAM, LIQUID 1420 POTASSIUM METAL ALLOYS, LIQUID 1421 ALKALI METAL ALLOY, LIQUID, N.O.S. 1422 POTASSIUM SODIUM ALLOYS, LIQUID 3398 ORGANOMETALLIC SUBSTANCE, LIQUID, WATER-REACTIVE 3148 WATER-REACTIVE LIQUID, N.O.S.
	solid	W2^a	1390 ALKALI METAL AMIDES 3401 ALKALI METAL AMALGAM, SOLID 3402 ALKALINE EARTH METAL AMALGAM, SOLID 3170 ALUMINIUM SMELTING BY-PRODUCTS or 3170 ALUMINIUM REMELTING BY-PRODUCTS 3403 POTASSIUM METAL ALLOYS, SOLID 3404 POTASSIUM SODIUM ALLOYS, SOLID 1393 ALKALINE EARTH METAL ALLOY, N.O.S. 1409 METAL HYDRIDES, WATER-REACTIVE, N.O.S. 3208 METALLIC SUBSTANCE, WATER-REACTIVE, N.O.S. 3395 ORGANOMETALLIC SUBSTANCE, SOLID, WATER-REACTIVE 2813 WATER-REACTIVE SOLID, N.O.S.
Without subsidiary risk	articles	W3	3292 BATTERIES, CONTAINING SODIUM or 3292 CELLS, CONTAINING SODIUM
Liquid, flammable		WF1	3399 ORGANOMETALLIC SUBSTANCE, LIQUID, WATER-REACTIVE, FLAMMABLE 3482 ALKALI METAL DISPERSION, FLAMMABLE or 3482 ALKALINE EARTH METAL DISPERSION, FLAMMABLE
Solid, flammable		WF2	3396 ORGANOMETALLIC SUBSTANCE, SOLID, WATER-REACTIVE, FLAMMABLE 3132 WATER-REACTIVE SOLID, FLAMMABLE, N.O.S.
Solid, self-heating		WS^b	3397 ORGANOMETALLIC SUBSTANCE, SOLID, WATER-REACTIVE, SELF-HEATING 3209 METALLIC SUBSTANCE, WATER-REACTIVE, SELF-HEATING, N.O.S. 3135 WATER-REACTIVE SOLID, SELF-HEATING, N.O.S.
Solid, oxidizing		WO	3133 WATER-REACTIVE SOLID, OXIDIZING, N.O.S. (not allowed, see 2.2.43.2)
Toxic	liquid	WT1	3130 WATER-REACTIVE LIQUID, TOXIC, N.O.S.
WT	solid	WT2	3134 WATER-REACTIVE SOLID, TOXIC, N.O.S.
Corrosive	liquid	WC1	3129 WATER-REACTIVE LIQUID, CORROSIVE, N.O.S.
WC	solid	WC2	3131 WATER-REACTIVE SOLID, CORROSIVE, N.O.S.
Flammable, corrosive		WFC^c	2988 CHLOROSILANES, WATER-REACTIVE, FLAMMABLE, CORROSIVE, NO.S. (No other collective entry with this classification code available, if need be, classification under a collective entry with a classification code to be determined according to the table of precedence of hazard in 2.1.3.10.)

^a *Metals and metal alloys which, in contact with water, do not emit flammable gases and are not pyrophoric or self-heating, but which are readily flammable, are substances of Class 4.1. Alkaline-earth metals and alkaline-earth metal alloys in pyrophoric form are substances of Class 4.2. Dust and powders of metals in pyrophoric form are substances of Class 4.2. Metals and metal alloys in pyrophoric form are substances of Class 4.2. Compounds of phosphorus with heavy metals such as iron, copper, etc. are not subject to the provisions of ADR.*

^b *Metals and metal alloys in pyrophoric form are substances of Class 4.2.*

^c *Chlorosilanes, having a flash-point of less than 23 °C and which, in contact with water, do not emit flammable gases, are substances of Class 3. Chlorosilanes, having a flash-point equal to or greater than 23 °C and which, in contact with water, do not emit flammable gases, are substances of Class 8.*

2.2.51 Class 5.1 Oxidizing substances

2.2.51.1 Criteria

2.2.51.1.1 The heading of Class 5.1 covers substances which, while in themselves not necessarily combustible, may, generally by yielding oxygen, cause or contribute to the combustion of other material, and articles containing such substances.

2.2.51.1.2 The substances of Class 5.1 and articles containing such substances are subdivided as follows:

O Oxidizing substances without subsidiary risk or articles containing such substances:

- O1 Liquid;
- O2 Solid;
- O3 Articles;

OF Oxidizing substances, solid, flammable;

OS Oxidizing substances, solid, self-heating;

OW Oxidizing substances, solid which, in contact with water, emit flammable gases;

OT Oxidizing substances, toxic:

- OT1 Liquid;
- OT2 Solid;

OC Oxidizing substances, corrosive:

- OC1 Liquid;
- OC2 Solid;

OTC Oxidizing substances, toxic, corrosive.

2.2.51.1.3 Substances and articles classified in Class 5.1 are listed in Table A of Chapter 3.2. The assignment of substances and articles not mentioned by name in Table A of Chapter 3.2 to the relevant entry of 2.2.51.3 in accordance with the provisions of Chapter 2.1 can be based on the tests, methods and criteria in paragraphs 2.2.51.1.6-2.2.51.1.9 below and the Manual of Tests and Criteria, Part III, Section 34.4. In the event of divergence between test results and known experience, judgement based on known experience shall take precedence over test results.

2.2.51.1.4 If substances of Class 5.1, as a result of admixtures, come into different categories of risk from those to which the substances mentioned by name in Table A of Chapter 3.2 belong, these mixtures or solutions shall be assigned to the entries to which they belong on the basis of their actual degree of danger.

NOTE: For the classification of solutions and mixtures (such as preparations and wastes), see also Section 2.1.3.

2.2.51.1.5 On the basis of the test procedures in the Manual of Tests and Criteria, Part III, Section 34.4 and the criteria set out in 2.2.51.1.6 to 2.2.51.1.9 it may also be determined whether the nature of a substance mentioned by name in Table A of Chapter 3.2 is such that the substance is not subject to the provisions for this class.

Oxidizing solids

Classification

- 2.2.51.1.6 When oxidizing solid substances not mentioned by name in Table A of Chapter 3.2 are assigned to one of the entries listed in 2.2.51.3 on the basis of the test procedure in accordance with the Manual of Tests and Criteria, Part III, sub-section 34.4.1, the following criteria shall apply:

A solid substance shall be assigned to Class 5.1 if, in the 4:1 or the 1:1 sample-to-cellulose ratio (by mass) tested, it ignites or burns or exhibits mean burning times equal to or less than that of a 3:7 mixture (by mass) of potassium bromate and cellulose.

Assignment of packing groups

- 2.2.51.1.7 Oxidizing solids classified under the various entries in Table A of Chapter 3.2 shall be assigned to packing groups I, II or III on the basis of test procedures of the Manual of Tests and Criteria, Part III, sub-section 34.4.1, in accordance with the following criteria:

- (a) Packing group I: any substance which, in the 4:1 or 1:1 sample-to-cellulose ratio (by mass) tested, exhibits a mean burning time less than the mean burning time of a 3:2 mixture, by mass, of potassium bromate and cellulose;
- (b) Packing group II: any substance which, in the 4:1 or 1:1 sample-to-cellulose ratio (by mass) tested, exhibits a mean burning time equal to or less than the mean burning time of a 2:3 mixture (by mass) of potassium bromate and cellulose and the criteria for packing group I are not met;
- (c) Packing group III: any substance which, in the 4:1 or 1:1 sample-to-cellulose ratio (by mass) tested, exhibits a mean burning time equal to or less than the mean burning time of a 3:7 mixture (by mass) of potassium bromate and cellulose and the criteria for packing groups I and II are not met.

Oxidizing liquids

Classification

- 2.2.51.1.8 When oxidizing liquid substances not mentioned by name in Table A of Chapter 3.2 are assigned to one of the entries listed in sub-section 2.2.51.3 on the basis of the test procedure in accordance with the Manual of Tests and Criteria, Part III, sub-section 34.4.2, the following criteria shall apply:

A liquid substance shall be assigned to Class 5.1 if, in the 1:1 mixture, by mass, of substance and cellulose tested, it exhibits a pressure rise of 2070 kPa gauge or more and a mean pressure rise time equal to or less than the mean pressure rise time of a 1:1 mixture, by mass, of 65% aqueous nitric acid and cellulose.

Assignment of packing groups

- 2.2.51.1.9 Oxidizing liquids classified under the various entries in Table A of Chapter 3.2 shall be assigned to packing groups I, II or III on the basis of test procedures of the Manual of Tests and Criteria, Part III, section 34.4.2, in accordance with the following criteria:

- (a) Packing group I: any substance which, in the 1:1 mixture, by mass, of substance and cellulose tested, spontaneously ignites; or the mean pressure rise time of a 1:1 mixture, by mass, of substance and cellulose is less than that of a 1:1 mixture, by mass, of 50% perchloric acid and cellulose;
- (b) Packing group II: any substance which, in the 1:1 mixture, by mass, of substance and cellulose tested, exhibits a mean pressure rise time less than or equal to the mean pressure rise time of a 1:1 mixture, by mass, of 40% aqueous sodium chlorate solution and cellulose; and the criteria for packing group I are not met;
- (c) Packing group III: any substance which, in the 1:1 mixture, by mass, of substance and cellulose tested, exhibits a mean pressure rise time less than or equal to the mean pressure rise time of a 1:1 mixture, by mass, of 65% aqueous nitric acid and cellulose; and the criteria for packing groups I and II are not met.

2.2.51.2 *Substances not accepted for carriage*

2.2.51.2.1 The chemically unstable substances of Class 5.1 shall not be accepted for carriage unless the necessary steps have been taken to prevent their dangerous decomposition or polymerization during carriage. To this end it shall in particular be ensured that receptacles and tanks do not contain any material liable to promote these reactions.

2.2.51.2.2 The following substances and mixtures shall not be accepted for carriage:

- oxidizing solids, self-heating, assigned to UN No. 3100, oxidizing solids, water-reactive, assigned to UN No. 3121 and oxidizing solids, flammable, assigned to UN No. 3137, unless they meet the requirements for Class 1 (see also 2.1.3.7);
- hydrogen peroxide, not stabilized or hydrogen peroxide, aqueous solutions, not stabilized containing more than 60% hydrogen peroxide;
- tetranitromethane not free from combustible impurities;
- perchloric acid solutions containing more than 72% (mass) acid, or mixtures of perchloric acid with any liquid other than water;
- chloric acid solution containing more than 10% chloric acid or mixtures of chloric acid with any liquid other than water;
- halogenated fluor compounds other than UN Nos. 1745 BROMINE PENTAFLUORIDE; 1746 BROMINE TRIFLUORIDE and 2495 IODINE PENTAFLUORIDE of Class 5.1 as well as UN Nos. 1749 CHLORINE TRIFLUORIDE and 2548 CHLORINE PENTAFLUORIDE of Class 2;
- ammonium chlorate and its aqueous solutions and mixtures of a chlorate with an ammonium salt;
- ammonium chlorite and its aqueous solutions and mixtures of a chlorite with an ammonium salt;
- mixtures of a hypochlorite with an ammonium salt;
- ammonium bromate and its aqueous solutions and mixtures of a bromate with an ammonium salt;

- ammonium permanganate and its aqueous solutions and mixtures of a permanganate with an ammonium salt;
- ammonium nitrate containing more than 0.2% combustible substances (including any organic substance calculated as carbon) unless it is a constituent of a substance or article of Class 1;
- fertilizers having an ammonium nitrate content (in determining the ammonium nitrate content, all nitrate ions for which a molecular equivalent of ammonium ions is present in the mixture shall be calculated as ammonium nitrate) or a content in combustible substances exceeding the values specified in special provision 307 except under the conditions applicable to Class 1;
- ammonium nitrite and its aqueous solutions and mixtures of an inorganic nitrite with an ammonium salt;
- mixtures of potassium nitrate, sodium nitrite and an ammonium salt.

2.2.51.3 *List of collective entries*

Oxidizing substances	liquid	O1	3210 CHLORATES, INORGANIC, AQUEOUS SOLUTION, N.O.S. 3211 PERCHLORATES, INORGANIC, AQUEOUS SOLUTION, N.O.S. 3213 BROMATES, INORGANIC, AQUEOUS SOLUTION, N.O.S. 3214 PERMANGANATES, INORGANIC, AQUEOUS SOLUTION, N.O.S. 3216 PERSULPHATES, INORGANIC, AQUEOUS SOLUTION, N.O.S. 3218 NITRATES, INORGANIC, AQUEOUS SOLUTION, N.O.S. 3219 NITRITES, INORGANIC, AQUEOUS SOLUTION, N.O.S. 3139 OXIDIZING LIQUID, N.O.S.
			1450 BROMATES, INORGANIC, N.O.S 1461 CHLORATES, INORGANIC, N.O.S. 1462 CHLORITES, INORGANIC, N.O.S. 1477 NITRATES, INORGANIC, N.O.S 1481 PERCHLORATES, INORGANIC, N.O.S. 1482 PERMANGANATES, INORGANIC, N.O.S. 1483 PEROXIDES, INORGANIC, N.O.S 2627 NITRITES, INORGANIC, N.O.S. 3212 HYPOCHLORITES, INORGANIC, N.O.S. 3215 PERSULPHATES, INORGANIC, N.O.S. 1479 OXIDIZING SOLID, N.O.S.
Without subsidiary risk	solid	O2	3356 OXYGEN GENERATOR, CHEMICAL
O	articles	O3	3356 OXYGEN GENERATOR, CHEMICAL
Solid, flammable		OF	3137 OXIDIZING SOLID, FLAMMABLE, N.O.S. (not allowed, see 2.2.51.2)
Solid, self-heating		OS	3100 OXIDIZING SOLID, SELF-HEATING, N.O.S. (not allowed, see 2.2.51.2)
Solid, water reactive		OW	3121 OXIDIZING SOLID, WATER REACTIVE, N.O.S. (not allowed, see 2.2.51.2)
Toxic	liquid	OT1	3099 OXIDIZING LIQUID, TOXIC, N.O.S.
	OT	solid	OT2
Corrosive	liquid	OC1	3098 OXIDIZING LIQUID, CORROSIVE, N.O.S.
	OC	solid	OC2
Toxic, corrosive		OTC	(No collective entry with this classification code available; if need be, classification under a collective entry with a classification code to be determined according to the table of precedence of hazard in 2.1.3.10.)

2.2.52 Class 5.2 Organic peroxides**2.2.52.1 Criteria**

2.2.52.1.1 The heading of Class 5.2 covers organic peroxides and formulations of organic peroxides.

2.2.52.1.2 The substances of Class 5.2 are subdivided as follows:

- P1 Organic peroxides, not requiring temperature control;
 P2 Organic peroxides, requiring temperature control.

Definition

2.2.52.1.3 *Organic peroxides* are organic substances which contain the bivalent -O-O- structure and may be considered derivatives of hydrogen peroxide, where one or both of the hydrogen atoms have been replaced by organic radicals.

Properties

2.2.52.1.4 Organic peroxides are liable to exothermic decomposition at normal or elevated temperatures. The decomposition can be initiated by heat, contact with impurities (e.g. acids, heavy-metal compounds, amines), friction or impact. The rate of decomposition increases with temperature and varies with the organic peroxide formulation. Decomposition may result in the evolution of harmful, or flammable, gases or vapours. For certain organic peroxides the temperature shall be controlled during carriage. Some organic peroxides may decompose explosively, particularly if confined. This characteristic may be modified by the addition of diluents or by the use of appropriate packagings. Many organic peroxides burn vigorously. Contact of organic peroxides with the eyes is to be avoided. Some organic peroxides will cause serious injury to the cornea, even after brief contact, or will be corrosive to the skin.

NOTE: Test methods for determining the flammability of organic peroxides are set out in the *Manual of Tests and Criteria, Part III, sub-section 32.4*. Because organic peroxides may react vigorously when heated, it is recommended to determine their flash-point using small sample sizes such as described in *ISO 3679:1983*.

Classification

2.2.52.1.5 Any organic peroxide shall be considered for classification in Class 5.2 unless the organic peroxide formulation contains:

- (a) Not more than 1.0% available oxygen from the organic peroxides when containing not more than 1.0% hydrogen peroxide;
- (b) Not more than 0.5% available oxygen from the organic peroxides when containing more than 1.0% but not more than 7.0% hydrogen peroxide.

NOTE: The available oxygen content (%) of an organic peroxide formulation is given by the formula

$$16 \times \sum (n_i \times c_i / m_i)$$

where:

- n_i = number of peroxygen groups per molecule of organic peroxide i ;
 c_i = concentration (mass %) of organic peroxide i ; and
 m_i = molecular mass of organic peroxide i .

2.2.52.1.6 Organic peroxides are classified into seven types according to the degree of danger they present. The types of organic peroxide range from type A, which is not accepted for carriage in the packaging in which it is tested, to type G, which is not subject to the provisions of Class 5.2. The classification of types B to F is directly related to the maximum quantity allowed in one packaging. The principles to be applied to the classification of substances not listed in 2.2.52.4 are set out in the Manual of Tests and Criteria, Part II.

2.2.52.1.7 Organic peroxides which have already been classified and are already permitted for carriage in packagings are listed in 2.2.52.4, those already permitted for carriage in IBCs are listed in 4.1.4.2, packing instruction IBC520 and those already permitted for carriage in tanks in accordance with Chapters 4.2 and 4.3 are listed in 4.2.5.2, portable tank instruction T23. Each permitted substance listed is assigned to a generic entry of Table A of Chapter 3.2 (UN Nos. 3101 to 3120) and appropriate subsidiary risks and remarks providing relevant transport information are given.

These generic entries specify:

- the type (B to F) of organic peroxide (see 2.2.52.1.6 above);
- physical state (liquid/solid); and
- temperature control (when required), see 2.2.52.1.15 to 2.2.52.1.18.

Mixtures of these formulations may be classified as the same type of organic peroxide as that of the most dangerous component and be carried under the conditions of carriage given for this type. However, as two stable components can form a thermally less stable mixture, the self-accelerating decomposition temperature (SADT) of the mixture shall be determined and, if necessary, the control and emergency temperatures derived from the SADT in accordance with 2.2.52.1.16.

2.2.52.1.8 Classification of organic peroxides, formulations or mixtures of organic peroxides not listed in 2.2.52.4, 4.1.4.2 packing instruction IBC520 or 4.2.5.2, portable tank instruction T23, and assignment to a collective entry shall be made by the competent authority of the country of origin. The statement of approval shall contain the classification and the relevant conditions of carriage. If the country of origin is not a Contracting Party to ADR, the classification and conditions of carriage shall be recognized by the competent authority of the first country Contracting Party to ADR reached by the consignment.

2.2.52.1.9 Samples of organic peroxides or formulations of organic peroxides not listed in 2.2.52.4, for which a complete set of test results is not available and which are to be carried for further testing or evaluation, shall be assigned to one of the appropriate entries for organic peroxides type C provided the following conditions are met:

- the available data indicate that the sample would be no more dangerous than organic peroxides type B;
- the sample is packaged in accordance with packing method OP2 and the quantity per transport unit is limited to 10 kg;
- the available data indicate that the control temperature, if any, is sufficiently low to prevent any dangerous decomposition and sufficiently high to prevent any dangerous phase separation.

Desensitization of organic peroxides

- 2.2.52.1.10 In order to ensure safety during carriage, organic peroxides are in many cases desensitized by organic liquids or solids, inorganic solids or water. Where a percentage of a substance is stipulated, this refers to the percentage by mass, rounded to the nearest whole number. In general, desensitization shall be such that, in case of spillage, the organic peroxide will not concentrate to a dangerous extent.
- 2.2.52.1.11 Unless otherwise stated for the individual organic peroxide formulation, the following definition(s) shall apply to diluents used for desensitization:
- diluents type A are organic liquids which are compatible with the organic peroxide and which have a boiling point of not less than 150 °C. Type A diluents may be used for desensitizing all organic peroxides;
 - diluents type B are organic liquids which are compatible with the organic peroxide and which have a boiling point of less than 150 °C but not less than 60 °C and a flash-point of not less than 5 °C.
- Type B diluents may be used for desensitization of all organic peroxides provided that the boiling point of the liquid is at least 60 °C higher than the SADT in a 50 kg package.
- 2.2.52.1.12 Diluents, other than type A or type B, may be added to organic peroxide formulations as listed in 2.2.52.4 provided that they are compatible. However, replacement of all or part of a type A or type B diluent by another diluent with differing properties requires that the organic peroxide formulation be re-assessed in accordance with the normal acceptance procedure for Class 5.2.
- 2.2.52.1.13 Water may only be used for the desensitization of organic peroxides which are listed in 2.2.52.4 or in the competent authority decision according to 2.2.52.1.8 as being "with water" or "as a stable dispersion in water". Samples of organic peroxides or formulations of organic peroxides not listed in 2.2.52.4 may also be desensitized with water provided the requirements of 2.2.52.1.9 are met.
- 2.2.52.1.14 Organic and inorganic solids may be used for desensitization of organic peroxides provided that they are compatible. Compatible liquids and solids are those which have no detrimental influence on the thermal stability and hazard type of the organic peroxide formulation.

Temperature control requirements

- 2.2.52.1.15 Certain organic peroxides may only be carried under temperature-controlled conditions. The control temperature is the maximum temperature at which the organic peroxide can be safely carried. It is assumed that the temperature of the immediate surroundings of a package only exceeds 55 °C during carriage for a relatively short time in a 24 hour period. In the event of loss of temperature control, it may be necessary to implement emergency procedures. The emergency temperature is the temperature at which such procedures shall be implemented.
- 2.2.52.1.16 The control and emergency temperatures are derived from the SADT which is defined as the lowest temperature at which self-accelerating decomposition may occur with a substance in the packaging as used during carriage (see Table 1). The SADT shall be determined in order to decide whether a substance shall be subjected to temperature control during carriage. Provisions for the determination of the SADT are given in the Manual of Tests and Criteria, Part II, Sections 20 and 28.4.

Table 1: Derivation of control and emergency temperatures

Type of receptacle	SADT ^a	Control temperature	Emergency temperature
Single packagings and IBCs	20 °C or less	20 °C below SADT	10 °C below SADT
	over 20 °C to 35 °C	15 °C below SADT	10 °C below SADT
	over 35 °C	10 °C below SADT	5 °C below SADT
Tanks	not greater than 50 °C	10 °C below SADT	5 °C below SADT

^a *SADT of the substance as packaged for carriage*

2.2.52.1.17 The following organic peroxides shall be subject to temperature control during carriage:

- organic peroxides types B and C with an SADT ≤ 50 °C;
- organic peroxides type D showing a medium effect when heated under confinement with an SADT ≤ 50 °C or showing a low or no effect when heated under confinement with an SADT ≤ 45 °C; and
- organic peroxides types E and F with an SADT ≤ 45 °C.

NOTE: Provisions for the determination of the effects of heating under confinement are given in the Manual of Tests and Criteria, Part II, Section 20 and Sub-section 28.4.

2.2.52.1.18 Where applicable, control and emergency temperatures are listed in 2.2.52.4. The actual temperature during carriage may be lower than the control temperature but shall be selected so as to avoid dangerous separation of phases.

2.2.52.2 Substances not accepted for carriage

Organic peroxides, type A, shall not be accepted for carriage under the provisions of Class 5.2 (see Manual of Tests and Criteria, Part II, paragraph 20.4.3 (a)).

2.2.52.3 *List of collective entries*

Organic peroxides		ORGANIC PEROXIDE TYPE A, LIQUID	} Not accepted for carriage, see 2.2.52.2		
		ORGANIC PEROXIDE TYPE A, SOLID			
	3101	ORGANIC PEROXIDE TYPE B, LIQUID			
	3102	ORGANIC PEROXIDE TYPE B, SOLID			
	3103	ORGANIC PEROXIDE TYPE C, LIQUID			
	3104	ORGANIC PEROXIDE TYPE C, SOLID			
	Not requiring temperature control	P1	3105	ORGANIC PEROXIDE TYPE D, LIQUID	
			3106	ORGANIC PEROXIDE TYPE D, SOLID	
			3107	ORGANIC PEROXIDE TYPE E, LIQUID	
			3108	ORGANIC PEROXIDE TYPE E, SOLID	
			3109	ORGANIC PEROXIDE TYPE F, LIQUID	
		3110	ORGANIC PEROXIDE TYPE F, SOLID		
		ORGANIC PEROXIDE TYPE G, LIQUID	} Not subject to the provisions applicable to Class 5.2, see 2.2.52.1.6		
		ORGANIC PEROXIDE TYPE G, SOLID			
Requiring temperature control	P2	3111	ORGANIC PEROXIDE TYPE B, LIQUID, TEMPERATURE CONTROLLED		
		3112	ORGANIC PEROXIDE TYPE B, SOLID, TEMPERATURE CONTROLLED		
		3113	ORGANIC PEROXIDE TYPE C, LIQUID, TEMPERATURE CONTROLLED		
		3114	ORGANIC PEROXIDE TYPE C, SOLID, TEMPERATURE CONTROLLED		
		3115	ORGANIC PEROXIDE TYPE D, LIQUID, TEMPERATURE CONTROLLED		
		3116	ORGANIC PEROXIDE TYPE D, SOLID, TEMPERATURE CONTROLLED		
		3117	ORGANIC PEROXIDE TYPE E, LIQUID, TEMPERATURE CONTROLLED		
		3118	ORGANIC PEROXIDE TYPE E, SOLID, TEMPERATURE CONTROLLED		
		3119	ORGANIC PEROXIDE TYPE F, LIQUID, TEMPERATURE CONTROLLED		
		3120	ORGANIC PEROXIDE TYPE F, SOLID, TEMPERATURE CONTROLLED		

2.2.52.4 *List of currently assigned organic peroxides in packagings*

In the column "Packing Method", codes "OP1" to "OP8" refer to packing methods in 4.1.4.1, packing instruction P520 (see also 4.1.7.1). Organic peroxides to be carried shall fulfil the classification and the control and emergency temperatures (derived from the SADT) as listed. For substances permitted in IBCs, see 4.1.4.2, packing instruction IBC520 and, for those permitted in tanks according to Chapters 4.2 and 4.3, see 4.2.5.2, portable tank instruction T23.

ORGANIC PEROXIDE	Concentration (%)	Diluent type A (%)	Diluent type B (%) 1)	Inert solid (%)	Water	Packing Method	Control temperature (°C)	Emergency temperature (°C)	Number (Generic entry)	Subsidiary risks and remarks
ACETYL ACETONE PEROXIDE	≤ 42	≥ 48			≥ 8	OP7			3105	2)
"	≤ 32 as a paste					OP7			3106	20)
ACETYL CYCLOHEXANESULPHONYL PEROXIDE	≤ 82				≥ 12	OP4	-10	0	3112	3)
"	≤ 32		≥ 68			OP7	-10	0	3115	
tert-AMYL HYDROPEROXIDE	≤ 88	≥ 6			≥ 6	OP8			3107	
tert-AMYL PEROXYACETATE	≤ 62	≥ 38				OP7			3105	
tert-AMYL PEROXYBENZOATE	≤ 100					OP5			3103	
tert-AMYL PEROXY-2-ETHYLHEXANOATE	≤ 100					OP7	+20	+25	3115	
tert-AMYL PEROXY-2-ETHYLHEXYL CARBONATE	≤ 100					OP7			3105	
tert-AMYL PEROXY ISOPROPYL CARBONATE	≤ 77	≥ 23				OP5			3103	
tert-AMYL PEROXYNEODECANOATE	≤ 77		≥ 23			OP7	0	+10	3115	
"	≤ 47	≥ 53				OP8	0	+10	3119	
tert-AMYL PEROXYPIVALATE	≤ 77		≥ 23			OP5	+10	+15	3113	
tert-AMYLPEROXY-3,5,5-TRIMETHYLHEXANOATE	≤ 100					OP7			3105	
tert-BUTYL CUMYL PEROXIDE	> 42 - 100					OP8			3107	
"	≤ 52			≥ 48		OP8			3108	
n-BUTYL-4,4-DI-(tert-BUTYLPEROXY)VALERATE	> 52 - 100					OP5			3103	
"	≤ 52			≥ 48		OP8			3108	
tert-BUTYL HYDROPEROXIDE	>79 - 90				≥ 10	OP5			3103	13)
"	≤ 80	≥ 20				OP7			3105	4) 13)
"	≤ 79				> 14	OP8			3107	13) 23)
"	≤ 72				≥ 28	OP8			3109	13)
tert-BUTYL HYDROPEROXIDE + DI-tert-BUTYLPEROXIDE	< 82 + >9				≥ 7	OP5			3103	13)

ORGANIC PEROXIDE	Concentration (%)	Diluent type A (%)	Diluent type B (%) 1)	Inert solid (%)	Water	Packing Method	Control temperature (°C)	Emergency temperature (°C)	Number (Generic entry)	Subsidiary risks and remarks
tert-BUTYL MONOPEROXYMALEATE	> 52 - 100					OP5			3102	3)
"	≤ 52	≥ 48				OP6			3103	
"	≤ 52			≥ 48		OP8			3108	
"	≤ 52 as a paste					OP8			3108	
tert-BUTYL PEROXYACETATE	> 52 - 77	≥ 23				OP5			3101	3)
"	> 32 - 52	≥ 48				OP6			3103	
"	≤ 32		≥ 68			OP8			3109	
tert-BUTYL PEROXYBENZOATE	> 77 - 100					OP5			3103	
"	> 52 - 77	≥ 23				OP7			3105	
"	≤ 52			≥ 48		OP7			3106	
tert-BUTYL PEROXYBUTYL FUMARATE	≤ 52	≥ 48				OP7			3105	
tert-BUTYL PEROXYCROTONATE	≤ 77	≥ 23				OP7			3105	
tert-BUTYL PEROXYDIETHYLACETATE	≤ 100					OP5	+20	+25	3113	
tert-BUTYL PEROXY-2-ETHYLHEXANOATE	> 52 - 100					OP6	+20	+25	3113	
"	> 32 - 52		≥ 48			OP8	+30	+35	3117	
"	≤ 52			≥ 48		OP8	+20	+25	3118	
"	≤ 32		≥ 68			OP8	+40	+45	3119	
tert-BUTYL PEROXY-2-ETHYLHEXANOATE + 2,2-DI-(tert-BUTYLPEROXY)BUTANE	≤ 12 + ≤ 14	≥ 14		≥ 60		OP7			3106	
"	≤ 31 + ≤ 36		≥ 33			OP7	+35	+40	3115	
tert-BUTYL PEROXY-2-ETHYLHEXYLCARBONATE	≤ 100					OP7			3105	
tert-BUTYL PEROXYISOBUTYRATE	> 52 - 77		≥ 23			OP5	+15	+20	3111	3)
"	≤ 52		≥ 48			OP7	+15	+20	3115	
tert-BUTYLPEROXY ISOPROPYLCARBONATE	≤ 77	≥ 23				OP5			3103	

ORGANIC PEROXIDE	Concentration (%)	Diluent type A (%)	Diluent type B (%) 1)	Inert solid (%)	Water	Packing Method	Control temperature (°C)	Emergency temperature (°C)	Number (Generic entry)	Subsidiary risks and remarks
1-(2-tert-BUTYLPEROXY ISOPROPYL)-3-ISOPROPENYL BENZENE	≤ 77	≥ 23				OP7			3105	
"	≤ 42			≥ 58		OP8			3108	
tert-BUTYL PEROXY-2-METHYLBENZOATE	≤ 100					OP5			3103	
tert-BUTYL PEROXYNEODECANOATE	> 77 - 100					OP7	-5	+5	3115	
"	≤ 77		≥ 23			OP7	0	+10	3115	
"	≤ 52 as a stable dispersion in water					OP8	0	+10	3119	
"	≤ 42 as a stable dispersion in water (frozen)					OP8	0	+10	3118	
"	≤ 32	≥ 68				OP8	0	+10	3119	
tert-BUTYL PEROXYNEOHEPTANOATE	≤ 77	≥ 23				OP7	0	+10	3115	
"	≤ 42 as a stable dispersion in water					OP8	0	+10	3117	
tert-BUTYL PEROXYPIVALATE	> 67 - 77	≥ 23				OP5	0	+10	3113	
"	> 27 - 67		≥ 33			OP7	0	+10	3115	
"	≤ 27		≥ 73			OP8	+30	+35	3119	
tert-BUTYLPEROXY STEARYLCARBONATE	≤ 100					OP7			3106	
tert-BUTYL PEROXY-3,5,5-TRIMETHYLHEXANOATE	> 32 - 100					OP7			3105	
"	≤ 42			≥ 58		OP7			3106	
"	≤ 32		≥ 68			OP8			3109	
3-CHLOROPEROXYBENZOIC ACID	> 57 - 86			≥ 14		OP1			3102	3)
"	≤ 57			≥ 3	≥ 40	OP7			3106	
"	≤ 77			≥ 6	≥ 17	OP7			3106	
CUMYL HYDROPEROXIDE	> 90 - 98	≤ 10				OP8			3107	13)
"	≤ 90	≥ 10				OP8			3109	13) 18)

ORGANIC PEROXIDE	Concentration (%)	Diluent type A (%)	Diluent type B (%) 1)	Inert solid (%)	Water	Packing Method	Control temperature (°C)	Emergency temperature (°C)	Number (Generic entry)	Subsidiary risks and remarks
CUMYL PEROXYNEODECANOATE	≤ 87	≥ 13				OP7	- 10	0	3115	
"	≤ 77		≥ 23			OP7	-10	0	3115	
"	≤ 52 as a stable dispersion in water					OP8	-10	0	3119	
CUMYL PEROXYNEOHEPTANOATE	≤ 77	≥ 23				OP7	-10	0	3115	
CUMYL PEROXYPIVALATE	≤ 77		≥ 23			OP7	-5	+5	3115	
CYCLOHEXANONE PEROXIDE(S)	≤ 91				≥ 9	OP6			3104	13)
"	≤ 72	≥ 28				OP7			3105	5)
"	≤ 72 as a paste					OP7			3106	5) 20)
"	≤ 32			≥ 68					Exempt	29)
DIACETONE ALCOHOL PEROXIDES	≤ 57		≥ 26		≥ 8	OP7	+40	+45	3115	6)
DIACETYL PEROXIDE	≤ 27		≥ 73			OP7	+20	+25	3115	7) 13)
DI-tert-AMYL PEROXIDE	≤ 100					OP8			3107	
2,2-DI-(tert-AMYLPEROXY)BUTANE	≤ 57	≥ 43				OP7			3105	
1,1-DI-(tert-AMYLPEROXY)CYCLOHEXANE	≤ 82	≥ 18				OP6			3103	
DIBENZOYL PEROXIDE	> 51 - 100			≤ 48		OP2			3102	3)
"	> 77 - 94				≥ 6	OP4			3102	3)
"	≤ 77				≥ 23	OP6			3104	
"	≤ 62			≥ 28	≥ 10	OP7			3106	
"	> 52 – 62 as a paste					OP7			3106	20)
"	> 35 - 52			≥ 48		OP7			3106	
"	> 36 - 42	≥ 18			≤ 40	OP8			3107	
"	≤ 56.5 as a paste				≥ 15	OP8			3108	
"	≤ 52 as a paste					OP8			3108	20)
"	≤ 42 as a stable dispersion in water					OP8			3109	
"	≤ 35			≥ 65					Exempt	29)

ORGANIC PEROXIDE	Concentration (%)	Diluent type A (%)	Diluent type B (%) 1)	Inert solid (%)	Water	Packing Method	Control temperature (°C)	Emergency temperature (°C)	Number (Generic entry)	Subsidiary risks and remarks
DI-(4-tert-BUTYLCYCLOHEXYL) PEROXYDICARBONATE	≤ 100					OP6	+30	+35	3114	
"	≤ 42 as a stable dispersion in water					OP8	+30	+35	3119	
DI-tert-BUTYL PEROXIDE	> 52 - 100					OP8			3107	
"	≤ 52		≥ 48			OP8			3109	25)
DI-tert-BUTYL PEROXYAZELATE	≤ 52	≥ 48				OP7			3105	
2,2-DI-(tert-BUTYLPEROXY)BUTANE	≤ 52	≥ 48				OP6			3103	
1,6-DI-(tert-BUTYLPEROXYCARBONYLOXY) HEXANE	≤ 72	≥ 28				OP5			3103	
1,1-DI-(tert-BUTYLPEROXY) CYCLOHEXANE	> 80 - 100					OP5			3101	3)
"	≤ 72		≥ 28			OP5			3103	30)
"	> 52 - 80	≥ 20				OP5			3103	
"	> 42 - 52	≥ 48				OP7			3105	
"	≤ 42	≥ 13		≥ 45		OP7			3106	
"	≤ 42	≥ 58				OP8			3109	
"	≤ 27	≥ 25				OP8			3107	21)
"	≤ 13	≥ 13	≥ 74			OP8			3109	
1,1-DI-(tert-BUTYLPEROXY) CYCLOHEXANE + tert-BUTYL PEROXY-2-ETHYLHEXANOATE	≤ 43 + ≤ 16	≥ 41				OP 7			3105	
DI-n-BUTYL PEROXYDICARBONATE	> 27 - 52		≥ 48			OP7	-15	-5	3115	
"	≤ 27		≥ 73			OP8	-10	0	3117	
"	≤ 42 as a stable dispersion in water (frozen)					OP8	-15	-5	3118	
DI-sec-BUTYL PEROXYDICARBONATE	> 52 - 100					OP4	-20	-10	3113	
"	≤ 52		≥ 48			OP7	-15	-5	3115	

ORGANIC PEROXIDE	Concentration (%)	Diluent type A (%)	Diluent type B (%) 1)	Inert solid (%)	Water	Packing Method	Control temperature (°C)	Emergency temperature (°C)	Number (Generic entry)	Subsidiary risks and remarks
DI-(tert-BUTYLPEROXYISOPROPYL)BENZENE(S)	> 42 - 100			≤ 57		OP7			3106	
"	≤ 42			≥ 58					Exempt	29)
DI-(tert-BUTYLPEROXY) PHTHALATE	> 42 - 52	≥ 48				OP7			3105	
"	≤ 52 as a paste					OP7			3106	20)
"	≤ 42	≥ 58				OP8			3107	
2,2-DI-(tert-BUTYLPEROXY)PROPANE	≤ 52	≥ 48				OP7			3105	
"	≤ 42	≥ 13		≥ 45		OP7			3106	
1,1-DI-(tert-BUTYLPEROXY)-3,3,5-TRIMETHYLCYCLOHEXANE	> 90 - 100					OP5			3101	3)
"	≤ 90		≥ 10			OP5			3103	30)
"	> 57 - 90	≥ 10				OP5			3103	
"	≤ 77		≥ 23			OP5			3103	
"	≤ 57			≥ 43		OP8			3110	
"	≤ 57	≥ 43				OP8			3107	
"	≤ 32	≥ 26	≥ 42			OP8			3107	
DICETYL PEROXYDICARBONATE	≤ 100					OP7	+30	+35	3116	
"	≤ 42 as a stable dispersion in water					OP8	+30	+35	3119	
DI-4-CHLOROBENZOYL PEROXIDE	≤ 77				≥ 23	OP5			3102	3)
"	≤ 52 as a paste					OP7			3106	20)
"	≤ 32			≥ 68					Exempt	29)
DICUMYL PEROXIDE	> 52 - 100					OP8			3110	12)
"	≤ 52			≥ 48					Exempt	29)
DICYCLOHEXYL PEROXYDICARBONATE	> 91 - 100					OP3	+10	+15	3112	3)
"	≤ 91				≥ 9	OP5	+10	+15	3114	
"	≤ 42 as a stable dispersion in water					OP8	+15	+20	3119	

ORGANIC PEROXIDE	Concentration (%)	Diluent type A (%)	Diluent type B (%) 1)	Inert solid (%)	Water	Packing Method	Control temperature (°C)	Emergency temperature (°C)	Number (Generic entry)	Subsidiary risks and remarks
DIDECANOYL PEROXIDE	≤ 100					OP6	+30	+35	3114	
2,2-DI-(4,4-DI (tert-BUTYLPEROXY) CYCLOHEXYL) PROPANE	≤ 42			≥ 58		OP7			3106	
"	≤ 22		≥ 78			OP8			3107	
DI-2,4-DICHLOROBENZOYL PEROXIDE	≤ 77				≥ 23	OP5			3102	3)
"	≤ 52 as a paste					OP8	+ 20	+ 25	3118	
"	≤ 52 as a paste with silicon oil					OP7			3106	
DI-(2-ETHOXYETHYL) PEROXYDICARBONATE	≤ 52		≥ 48			OP7	-10	0	3115	
DI-(2-ETHYLHEXYL) PEROXYDICARBONATE	> 77 – 100					OP5	-20	-10	3113	
"	≤ 77		≥ 23			OP7	-15	-5	3115	
"	≤ 62 as a stable dispersion in water					OP8	-15	-5	3119	
"	≤ 52 as a stable dispersion in water (frozen)					OP8	-15	-5	3120	
2,2-DIHYDROPEROXYPROPANE	≤ 27			≥ 73		OP5			3102	3)
DI-(1-HYDROXYCYCLOHEXYL) PEROXIDE	≤ 100					OP7			3106	
DIISOBUTYRYL PEROXIDE	> 32 – 52		≥ 48			OP5	-20	-10	3111	3)
"	≤ 32		≥ 68			OP7	-20	-10	3115	
DIISOPROPYLBENZENE DIHYDROPEROXIDE	≤ 82	≥ 5			≥ 5	OP7			3106	24)
DIISOPROPYL PEROXYDICARBONATE	> 52-100					OP2	-15	-5	3112	3)
"	≤ 52		≥ 48			OP7	-20	-10	3115	
"	≤ 28	≥ 72				OP7	-15	-5	3115	
DILAUROYL PEROXIDE	≤ 100					OP7			3106	
"	≤ 42 as a stable dispersion in water					OP8			3109	
DI-(3-METHOXYBUTYL) PEROXYDICARBONATE	≤ 52		≥ 48			OP7	-5	+5	3115	

ORGANIC PEROXIDE	Concentration (%)	Diluent type A (%)	Diluent type B (%) 1)	Inert solid (%)	Water	Packing Method	Control temperature (°C)	Emergency temperature (°C)	Number (Generic entry)	Subsidiary risks and remarks
DI-(2-METHYLBENZOYL) PEROXIDE	≤ 87				≥ 13	OP5	+30	+35	3112	3)
DI-(3-METHYLBENZOYL) PEROXIDE + BENZOYL (3-METHYLBENZOYL) PEROXIDE + DIBENZOYL PEROXIDE	≤ 20 + ≤ 18 + ≤ 4		≥ 58			OP7	+35	+40	3115	
DI-(4-METHYLBENZOYL) PEROXIDE	≤ 52 as a paste with silicon oil					OP7			3106	
2,5-DIMETHYL-2,5-DI-(BENZOYLPEROXY)HEXANE	> 82-100					OP5			3102	3)
"	≤ 82			≥ 18		OP7			3106	
"	≤ 82				≥ 18	OP5			3104	
2,5-DIMETHYL-2,5-DI-(tert-BUTYLPEROXY)HEXANE	> 90 - 100					OP5			3103	
"	> 52 - 90	≥ 10				OP7			3105	
"	≤ 77			≥ 23		OP8			3108	
"	≤ 52	≥ 48				OP8			3109	
"	≤ 47 as a paste					OP8			3108	
2,5-DIMETHYL-2,5-DI-(tert-BUTYLPEROXY)HEXYNE-3	> 86-100					OP5			3101	3)
"	>52-86	≥ 14				OP5			3103	26)
"	≤ 52			≥ 48		OP7			3106	
2,5-DIMETHYL-2,5-DI-(2-ETHYLHEXANOYLPEROXY)HEXANE	≤ 100					OP5	+20	+25	3113	
2,5-DIMETHYL-2,5-DIHYDROPEROXYHEXANE	≤ 82				≥ 18	OP6			3104	
2,5-DIMETHYL-2,5-DI-(3,5,5-TRIMETHYLHEXANOYLPEROXY)HEXANE	≤ 77	≥ 23				OP7			3105	
1,1-DIMETHYL-3-HYDROXYBUTYL PEROXYNEOHEPTANOATE	≤ 52	≥ 48				OP8	0	+10	3117	
DIMYRISTYL PEROXYDICARBONATE	≤ 100					OP7	+20	+25	3116	
"	≤ 42 as a stable dispersion in water					OP8	+20	+25	3119	

ORGANIC PEROXIDE	Concentration (%)	Diluent type A (%)	Diluent type B (%) 1)	Inert solid (%)	Water	Packing Method	Control temperature (°C)	Emergency temperature (°C)	Number (Generic entry)	Subsidiary risks and remarks
DI-(2-NEODECANOYLPEROXYISOPROPYL) BENZENE	≤ 52	≥ 48				OP7	-10	0	3115	
DI-n-NONANOYL PEROXIDE	≤ 100					OP7	0	+10	3116	
DI-n-OCTANOYL PEROXIDE	≤ 100					OP5	+10	+15	3114	
DI-(2-PHENOXYETHYL) PEROXYDICARBONATE	>85-100					OP5			3102	3)
"	≤ 85				≥ 15	OP7			3106	
DIPROPIONYL PEROXIDE	≤ 27		≥ 73			OP8	+15	+20	3117	
DI-n-PROPYL PEROXYDICARBONATE	≤ 100					OP3	-25	-15	3113	
"	≤ 77		≥ 23			OP5	-20	-10	3113	
DISUCCINIC ACID PEROXIDE	> 72-100					OP4			3102	3) 17)
"	≤ 72				≥ 28	OP7	+10	+15	3116	
DI-(3,5,5-TRIMETHYLHEXANOYL) PEROXIDE	> 38-82	≥ 18				OP7	0	+10	3115	
"	≤ 52 as a stable dispersion in water					OP8	+10	+15	3119	
"	≤ 38	≥ 62				OP8	+20	+25	3119	
ETHYL 3,3-DI-(tert-AMYLPEROXY)BUTYRATE	≤ 67	≥ 33				OP7			3105	
ETHYL 3,3-DI-(tert-BUTYLPEROXY)BUTYRATE	> 77 - 100					OP5			3103	
"	≤ 77	≥ 23				OP7			3105	
"	≤ 52			≥ 48		OP7			3106	
1-(2-ETHYLHEXANOYLPEROXY)-1,3-DIMETHYLBUTYL PEROXYPIVALATE	≤ 52	≥ 45	≥ 10			OP7	-20	-10	3115	
tert-HEXYL PEROXYNEODECANOATE	≤ 71	≥ 29				OP7	0	+10	3115	
tert-HEXYL PEROXYPIVALATE	≤ 72		≥ 28			OP7	+10	+15	3115	
3-HYDROXY-1,1-DIMETHYLBUTYL PEROXYNEODECANOATE	≤ 77	≥ 23				OP 7	- 5	+ 5	3115	
"	≤ 52	≥ 48				OP 8	- 5	+ 5	3117	
"	≤ 52 as a stable dispersion in water					OP 8	- 5	+ 5	3119	

ORGANIC PEROXIDE	Concentration (%)	Diluent type A (%)	Diluent type B (%) 1)	Inert solid (%)	Water	Packing Method	Control temperature (°C)	Emergency temperature (°C)	Number (Generic entry)	Subsidiary risks and remarks
ISOPROPYL sec-BUTYL PEROXYDICARBONATE +DI-sec-BUTYL PEROXYDICARBONATE +DI-ISOPROPYL PEROXYDICARBONATE	$\leq 32 + \leq 15 - 18$ $\leq 12 - 15$	≥ 38				OP7	-20	-10	3115	
"	$\leq 52 + \leq 28 + \leq 22$					OP5	-20	-10	3111	3)
ISOPROPYLCUMYL HYDROPEROXIDE	≤ 72	≥ 28				OP8			3109	13)
p-MENTHYL HYDROPEROXIDE	$> 72 - 100$					OP7			3105	13)
"	≤ 72	≥ 28				OP8			3109	27)
METHYLCYCLOHEXANONE PEROXIDE(S)	≤ 67		≥ 33			OP7	+35	+40	3115	
METHYL ETHYL KETONE PEROXIDE(S)	see remark 8)	≥ 48				OP5			3101	3) 8) 13)
"	see remark 9)	≥ 55				OP7			3105	9)
"	see remark 10)	≥ 60				OP8			3107	10)
METHYL ISOBUTYL KETONE PEROXIDE(S)	≤ 62	≥ 19				OP7			3105	22)
METHYL ISOPROPYL KETONE PEROXIDE(S)	see remark 31)	≥ 70				OP8			3109	31)
ORGANIC PEROXIDE, LIQUID, SAMPLE						OP2			3103	11)
ORGANIC PEROXIDE, LIQUID, SAMPLE, TEMPERATURE CONTROLLED						OP2			3113	11)
ORGANIC PEROXIDE, SOLID, SAMPLE						OP2			3104	11)
ORGANIC PEROXIDE, SOLID, SAMPLE, TEMPERATURE CONTROLLED						OP2			3114	11)
3,3,5,7,7-PENTAMETHYL-1,2,4-TRIOXEPANE	≤ 100					OP8			3107	
PEROXYACETIC ACID, TYPE D, stabilized	≤ 43					OP7			3105	13) 14) 19)
PEROXYACETIC ACID, TYPE E, stabilized	≤ 43					OP8			3107	13) 15) 19)
PEROXYACETIC ACID, TYPE F, stabilized	≤ 43					OP8			3109	13) 16) 19)
PEROXYLAURIC ACID	≤ 100					OP8	+35	+40	3118	
PINANYL HYDROPEROXIDE	$> 56 - 100$					OP7			3105	13)
"	≤ 56	≥ 44				OP8			3109	
POLYETHER POLY-tert-BUTYLPEROXY-CARBONATE	≤ 52		≥ 48			OP8			3107	

ORGANIC PEROXIDE	Concentration (%)	Diluent type A (%)	Diluent type B (%) 1)	Inert solid (%)	Water	Packing Method	Control temperature (°C)	Emergency temperature (°C)	Number (Generic entry)	Subsidiary risks and remarks
1,1,3,3-TETRAMETHYLBUTYL HYDROPEROXIDE	≤ 100					OP7			3105	
1,1,3,3-TETRAMETHYLBUTYL PEROXY-2-ETHYLHEXANOATE	≤ 100					OP7	+15	+20	3115	
1,1,3,3- TETRAMETHYLBUTYL PEROXYNEODECANOATE	≤ 72		≥ 28			OP7	-5	+5	3115	
"	≤ 52 as a stable dispersion in water					OP8	-5	+5	3119	
1,1,3,3-TETRAMETHYLBUTYL PEROXYPIVALATE	≤ 77	≥ 23				OP7	0	+10	3115	
3,6,9-TRIETHYL-3,6,9-TRIMETHYL-1,4,7 TRIPEROXONANE	≤ 42	≥ 58				OP7			3105	28)

Remarks (refer to the last column of the Table in 2.2.52.4):

- 1) Diluent type B may always be replaced by diluent type A. The boiling point of diluent type B shall be at least 60°C higher than the SADT of the organic peroxide.
- 2) Available oxygen $\leq 4.7\%$.
- 3) "EXPLOSIVE" subsidiary risk label required (Model No.1, see 5.2.2.2.2).
- 4) Diluent may be replaced by di-tert-butyl peroxide.
- 5) Available oxygen $\leq 9\%$.
- 6) With $\leq 9\%$ hydrogen peroxide; available oxygen $\leq 10\%$.
- 7) Only non-metallic packagings allowed.
- 8) Available oxygen $> 10\%$ and $\leq 10.7\%$, with or without water.
- 9) Available oxygen $\leq 10\%$, with or without water.
- 10) Available oxygen $\leq 8.2\%$, with or without water.
- 11) See 2.2.52.1.9.
- 12) Up to 2000 kg per receptacle assigned to ORGANIC PEROXIDE TYPE F on the basis of large scale trials.
- 13) "CORROSIVE" subsidiary risk label required (Model No.8, see 5.2.2.2.2).
- 14) Peroxyacetic acid formulations which fulfil the criteria of the Manual of Tests and Criteria, paragraph 20.4.3 (d).
- 15) Peroxyacetic acid formulations which fulfil the criteria of the Manual of Tests and Criteria, paragraph 20.4.3 (e).
- 16) Peroxyacetic acid formulations which fulfil the criteria of the Manual of Tests and Criteria, paragraph 20.4.3 (f).
- 17) Addition of water to this organic peroxide will decrease its thermal stability.
- 18) No "CORROSIVE" subsidiary risk label (Model No.8, see 5.2.2.2.2) required for concentrations below 80%.
- 19) Mixtures with hydrogen peroxide, water and acid(s).
- 20) With diluent type A, with or without water.
- 21) With $\geq 25\%$ diluent type A by mass, and in addition ethylbenzene.
- 22) With $\geq 19\%$, diluent type A by mass, and in addition methyl isobutyl ketone.
- 23) With $< 6\%$ di-tert-butyl peroxide.
- 24) With $\leq 8\%$ 1-isopropylhydroperoxy-4-isopropylhydroxybenzene.
- 25) Diluent type B with boiling point > 110 °C.
- 26) With $< 0.5\%$ hydroperoxides content.
- 27) For concentrations more than 56%, "CORROSIVE" subsidiary risk label required (Model No.8, see 5.2.2.2.2).
- 28) Available active oxygen $\leq 7.6\%$ in diluent type A having a 95% boil-off point in the range of 200 - 260 °C.
- 29) Not subject to the requirements of ADR for Class 5.2.
- 30) Diluent type B with boiling point > 130 °C.
- 31) Active oxygen $\leq 6.7\%$.

2.2.61 Class 6.1 Toxic substances

2.2.61.1 Criteria

2.2.61.1.1 The heading of Class 6.1 covers substances of which it is known by experience or regarding which it is presumed from experiments on animals that in relatively small quantities they are able by a single action or by action of short duration to cause damage to human health, or death, by inhalation, by cutaneous absorption or by ingestion.

***NOTE:** Genetically modified microorganisms and organisms shall be assigned to this Class if they meet the conditions for this Class.*

2.2.61.1.2 Substances of Class 6.1 are subdivided as follows:

T Toxic substances without subsidiary risk:

- T1 Organic, liquid;
- T2 Organic, solid;
- T3 Organometallic substances;
- T4 Inorganic, liquid;
- T5 Inorganic, solid;
- T6 Liquid, used as pesticides;
- T7 Solid, used as pesticides;
- T8 Samples;
- T9 Other toxic substances;

TF Toxic substances, flammable:

- TF1 Liquid;
- TF2 Liquid, used as pesticides;
- TF3 Solid;

TS Toxic substances, self-heating, solid;

TW Toxic substances, which, in contact with water, emit flammable gases:

- TW1 Liquid;
- TW2 Solid;

TO Toxic substances, oxidizing:

- TO1 Liquid;
- TO2 Solid;

TC Toxic substances, corrosive:

- TC1 Organic, liquid;
- TC2 Organic, solid;
- TC3 Inorganic, liquid;
- TC4 Inorganic, solid;

TFC Toxic substances, flammable, corrosive;

TFW Toxic substances, flammable, which, in contact with water, emit flammable gases.

Definitions

2.2.61.1.3 For the purposes of ADR:

LD₅₀ (median lethal dose) for acute oral toxicity is the statistically derived single dose of a substance that can be expected to cause death within 14 days in 50 per cent of young adult albino rats when administered by the oral route. The LD₅₀ value is expressed in terms of mass of test substance per mass of test animal (mg/kg);

LD₅₀ for acute dermal toxicity is that dose of the substance which, administered by continuous contact for 24 hours with the bare skin of albino rabbits, is most likely to cause death within 14 days in one half of the animals tested. The number of animals tested shall be sufficient to give a statistically significant result and be in conformity with good pharmacological practice. The result is expressed in milligrams per kg body mass;

LC₅₀ for acute toxicity on inhalation is that concentration of vapour, mist or dust which, administered by continuous inhalation to both male and female young adult albino rats for one hour, is most likely to cause death within 14 days in one half of the animals tested. A solid substance shall be tested if at least 10% (by mass) of its total mass is likely to be dust in a respirable range, e.g. the aerodynamic diameter of that particle-fraction is 10 µm or less. A liquid substance shall be tested if a mist is likely to be generated in a leakage of the transport containment. Both for solid and liquid substances more than 90% (by mass) of a specimen prepared for inhalation toxicity shall be in the respirable range as defined above. The result is expressed in milligrams per litre of air for dusts and mists or in millilitres per cubic metre of air (parts per million) for vapours.

Classification and assignment of packing groups

2.2.61.1.4 Substances of Class 6.1 shall be classified in three packing groups according to the degree of danger they present for carriage, as follows:

Packing group I:	highly toxic substances
Packing group II:	toxic substances
Packing group III:	slightly toxic substances.

2.2.61.1.5 Substances, mixtures, solutions and articles classified in Class 6.1 are listed in Table A of Chapter 3.2. The assignment of substances, mixtures and solutions not mentioned by name in Table A of Chapter 3.2 to the relevant entry of sub-section 2.2.61.3 and to the relevant packing group in accordance with the provisions of Chapter 2.1, shall be made according to the following criteria in 2.2.61.1.6 to 2.2.61.1.11.

2.2.61.1.6 To assess the degree of toxicity, account shall be taken of human experience of instances of accidental poisoning, as well as special properties possessed by any individual substances: liquid state, high volatility, any special likelihood of cutaneous absorption, and special biological effects.

2.2.61.1.7 In the absence of observations on humans, the degree of toxicity shall be assessed using the available data from animal experiments in accordance with the table below:

	Packing group	Oral toxicity LD ₅₀ (mg/kg)	Dermal toxicity LD ₅₀ (mg/kg)	Inhalation toxicity by dusts and mists LC ₅₀ (mg/l)
Highly toxic	I	≤ 5	≤ 50	≤ 0.2
Toxic	II	> 5 and ≤ 50	> 50 and ≤ 200	> 0.2 and ≤ 2
Slightly toxic	III ^a	> 50 and ≤ 300	> 200 and ≤ 1 000	> 2 and ≤ 4

^a *Tear gas substances shall be included in packing group II even if data concerning their toxicity correspond to packing group III criteria.*

2.2.61.1.7.1 Where a substance exhibits different degrees of toxicity for two or more kinds of exposure, it shall be classified under the highest such degree of toxicity.

2.2.61.1.7.2 Substances meeting the criteria of Class 8 and with an inhalation toxicity of dusts and mists (LC₅₀) leading to packing group I shall only be accepted for an allocation to Class 6.1 if the toxicity through oral ingestion or dermal contact is at least in the range of packing groups I or II. Otherwise an assignment to Class 8 shall be made if appropriate (see 2.2.8.1.5).

2.2.61.1.7.3 The criteria for inhalation toxicity of dusts and mists are based on LC₅₀ data relating to 1-hour exposure, and where such information is available it shall be used. However, where only LC₅₀ data relating to 4-hour exposure are available, such figures can be multiplied by four and the product substituted in the above criteria, i.e. LC₅₀ value multiplied by four (4 hour) is considered the equivalent of LC₅₀ (1 hour).

Inhalation toxicity of vapours

2.2.61.1.8 Liquids giving off toxic vapours shall be classified into the following groups where "V" is the saturated vapour concentration (in ml/m³ of air) (volatility) at 20 °C and standard atmospheric pressure:

	Packing group	
Highly toxic	I	Where $V \geq 10 LC_{50}$ and $LC_{50} \leq 1\ 000\ \text{ml/m}^3$
Toxic	II	Where $V \geq LC_{50}$ and $LC_{50} \leq 3\ 000\ \text{ml/m}^3$ and the criteria for packing group I are not met
Slightly toxic	III ^a	Where $V \geq 1/5 LC_{50}$ and $LC_{50} \leq 5\ 000\ \text{ml/m}^3$ and the criteria for packing groups I and II are not met

^a *Tear gas substances shall be included in packing group II even if data concerning their toxicity correspond to packing group III criteria.*

These criteria for inhalation toxicity of vapours are based on LC₅₀ data relating to 1-hour exposure, and where such information is available, it shall be used.

However, where only LC₅₀ data relating to 4-hour exposure to the vapours are available, such figures can be multiplied by two and the product substituted in the above criteria, i.e. LC₅₀ (4 hour) × 2 is considered the equivalent of LC₅₀ (1 hour).

In this figure, the criteria are expressed in graphical form, as an aid to easy classification. However, due to approximations inherent in the use of graphs, substances falling on or near group borderlines shall be checked using numerical criteria.

GROUP BORDERLINES INHALATION TOXICITY OF VAPOURS

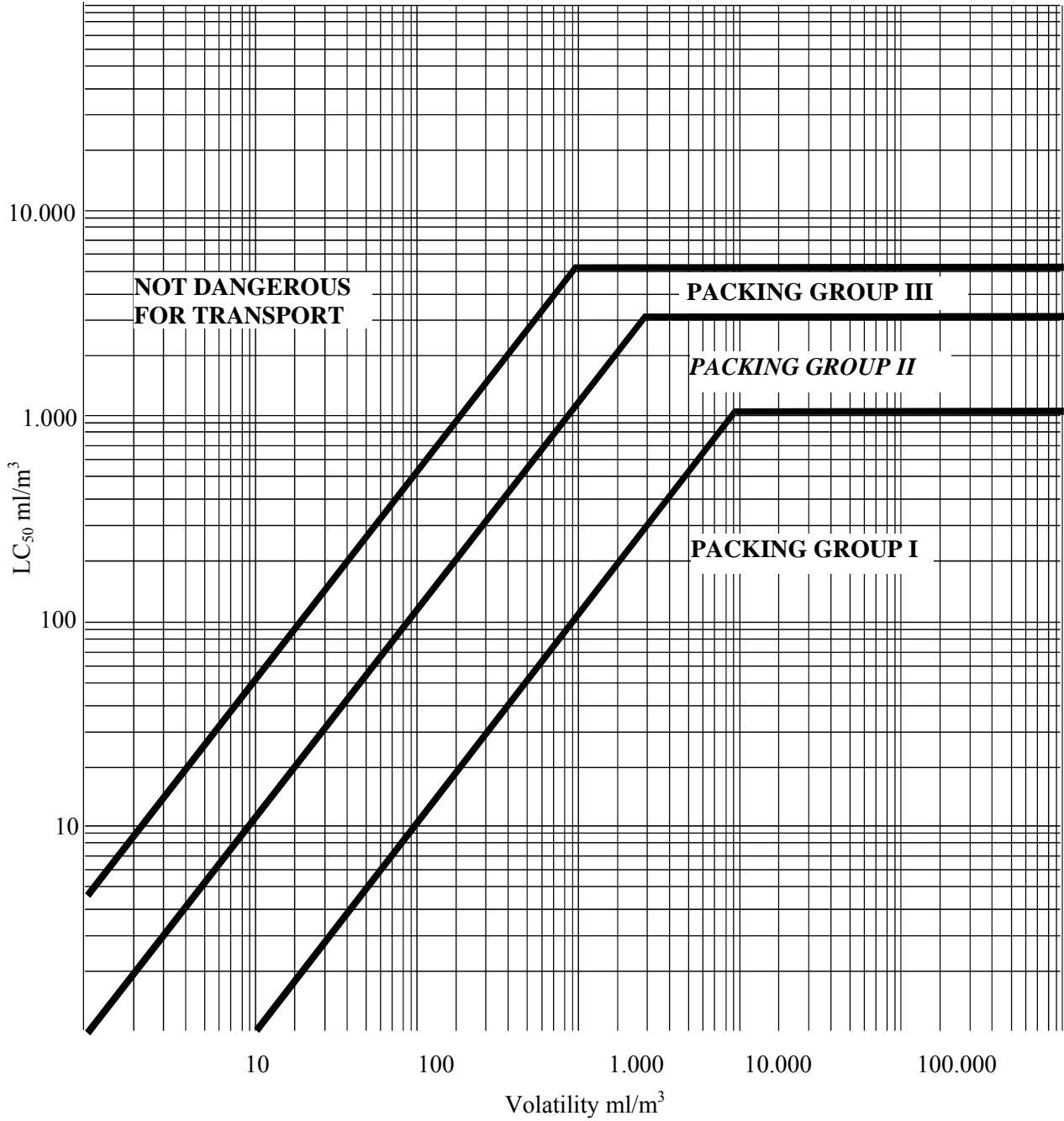

Mixtures of liquids

2.2.61.1.9 Mixtures of liquids which are toxic on inhalation shall be assigned to packing groups according to the following criteria:

2.2.61.1.9.1 If LC_{50} is known for each of the toxic substances constituting the mixture, the packing group may be determined as follows:

(a) calculation of the LC_{50} of the mixture:

$$LC_{50} (\text{mixture}) = \frac{1}{\sum_{i=1}^n \frac{f_i}{LC_{50i}}}$$

where f_i = molar fraction of constituent i of the mixture;

LC_{50i} = average lethal concentration of constituent i in ml/m^3 .

(b) calculation of volatility of each mixture constituent:

$$V_i = P_i \times \frac{10^6}{101.3} (\text{ml/m}^3)$$

where P_i = partial pressure of constituent i in kPa at 20 °C and at standard atmospheric pressure.

(c) calculation of the ratio of volatility to LC_{50} :

$$R = \sum_{i=1}^n \frac{V_i}{LC_{50i}}$$

(d) the values calculated for LC_{50} (mixture) and R are then used to determine the packing group of the mixture:

Packing group I $R \geq 10$ and LC_{50} (mixture) $\leq 1\,000 \text{ ml/m}^3$;

Packing group II $R \geq 1$ and LC_{50} (mixture) $\leq 3\,000 \text{ ml/m}^3$, if the mixture does not meet the criteria for packing group I;

Packing group III $R \geq 1/5$ and LC_{50} (mixture) $\leq 5\,000 \text{ ml/m}^3$, if the mixture does not meet the criteria of packing groups I or II.

2.2.61.1.9.2 In the absence of LC_{50} data on the toxic constituent substances, the mixture may be assigned to a group based on the following simplified threshold toxicity tests. When these threshold tests are used, the most restrictive group shall be determined and used for carrying the mixture.

- 2.2.61.1.9.3 A mixture is assigned to packing group I only if it meets both of the following criteria:
- A sample of the liquid mixture is vaporized and diluted with air to create a test atmosphere of 1 000 ml/m³ vaporized mixture in air. Ten albino rats (5 male and 5 female) are exposed to the test atmosphere for 1 hour and observed for 14 days. If five or more of the animals die within the 14-day observation period, the mixture is presumed to have an LC₅₀ equal to or less than 1 000 ml/m³;
 - A sample of vapour in equilibrium with the liquid mixture is diluted with 9 equal volumes of air to form a test atmosphere. Ten albino rats (5 male and 5 female) are exposed to the test atmosphere for 1 hour and observed for 14 days. If five or more of the animals die within the 14-day observation period, the mixture is presumed to have a volatility equal to or greater than 10 times the mixture LC₅₀.
- 2.2.61.1.9.4 A mixture is assigned to packing group II only if it meets both of the following criteria, and does not meet the criteria for packing group I:
- A sample of the liquid mixture is vaporized and diluted with air to create a test atmosphere of 3 000 ml/m³ vaporized mixture in air. Ten albino rats (5 male and 5 female) are exposed to the test atmosphere for 1 hour and observed for 14 days. If five or more of the animals die within the 14-day observation period, the mixture is presumed to have an LC₅₀ equal to or less than 3 000 ml/m³;
 - A sample of the vapour in equilibrium with the liquid mixture is used to form a test atmosphere. Ten albino rats (5 male and 5 female) are exposed to the test atmosphere for 1 hour and observed for 14 days. If five or more of the animals die within the 14-day observation period, the mixture is presumed to have a volatility equal to or greater than the mixture LC₅₀.
- 2.2.61.1.9.5 A mixture is assigned to packing group III only if it meets both of the following criteria, and does not meet the criteria for packing groups I or II:
- A sample of the liquid mixture is vaporized and diluted with air to create a test atmosphere of 5 000 ml/m³ vaporized mixture in air. Ten albino rats (5 male and 5 female) are exposed to the test atmosphere for 1 hour and observed for 14 days. If five or more of the animals die within the 14-day observation period, the mixture is presumed to have an LC₅₀ equal to or less than 5 000 ml/m³;
 - The vapour concentration (volatility) of the liquid mixture is measured and if the vapour concentration is equal to or greater than 1 000 ml/m³, the mixture is presumed to have a volatility equal to or greater than 1/5 the mixture LC₅₀.

Methods for determining oral and dermal toxicity of mixtures

- 2.2.61.1.10 When classifying and assigning the appropriate packing group to mixtures in Class 6.1 in accordance with the oral and dermal toxicity criteria (see 2.2.61.1.3), it is necessary to determine the acute LD₅₀ of the mixture.
- 2.2.61.1.10.1 If a mixture contains only one active substance, and the LD₅₀ of that constituent is known, in the absence of reliable acute oral and dermal toxicity data on the actual mixture to be carried, the oral or dermal LD₅₀ may be obtained by the following method:

$$\text{LD}_{50} \text{ value of preparation} = \frac{\text{LD}_{50} \text{ value of active substance} \times 100}{\text{percentage of active substance by mass}}$$

2.2.61.1.10.2 If a mixture contains more than one active constituent, there are three possible approaches that may be used to determine the oral or dermal LD₅₀ of the mixture. The preferred method is to obtain reliable acute oral and dermal toxicity data on the actual mixture to be carried. If reliable, accurate data are not available, then either of the following methods may be performed:

- (a) Classify the formulation according to the most hazardous constituent of the mixture as if that constituent were present in the same concentration as the total concentration of all active constituents; or
- (b) Apply the formula:

$$\frac{C_A}{T_A} + \frac{C_B}{T_B} + \dots + \frac{C_Z}{T_Z} = \frac{100}{T_M}$$

where:

C = the percentage concentration of constituent A, B, ..., Z in the mixture;

T = the oral LD₅₀ values of constituent A, B, ... Z;

T_M = the oral LD₅₀ value of the mixture.

NOTE: This formula can also be used for dermal toxicities provided that this information is available on the same species for all constituents. The use of this formula does not take into account any potentiation or protective phenomena.

Classification of pesticides

2.2.61.1.11 All active pesticide substances and their preparations for which the LC₅₀ and/or LD₅₀ values are known and which are classified in Class 6.1 shall be classified under appropriate packing groups in accordance with the criteria given in 2.2.61.1.6 to 2.2.61.1.9. Substances and preparations which are characterized by subsidiary risks shall be classified according to the precedence of hazard Table in 2.1.3.10 with the assignment of appropriate packing groups.

2.2.61.1.11.1 If the oral or dermal LD₅₀ value for a pesticide preparation is not known, but the LD₅₀ value of its active substance(s) is known, the LD₅₀ value for the preparation may be obtained by applying the procedures in 2.2.61.1.10.

NOTE: LD₅₀ toxicity data for a number of common pesticides may be obtained from the most current edition of the document "The WHO Recommended Classification of Pesticides by Hazard and Guidelines to Classification" available from the International Programme on Chemical Safety, World Health Organisation (WHO), 1211 Geneva 27, Switzerland. While that document may be used as a source of LD₅₀ data for pesticides, its classification system shall not be used for purposes of transport classification of, or assignment of packing groups to, pesticides, which shall be in accordance with the requirements of ADR.

2.2.61.1.11.2 The proper shipping name used in the carriage of the pesticide shall be selected on the basis of the active ingredient, of the physical state of the pesticide and any subsidiary risks it may exhibit (see 3.1.2).

2.2.61.1.12 If substances of Class 6.1, as a result of admixtures, come into categories of risk different from those to which the substances mentioned by name in Table A of Chapter 3.2 belong, these mixtures or solutions shall be assigned to the entries to which they belong on the basis of their actual degree of danger.

NOTE: For the classification of solutions and mixtures (such as preparations and wastes), see also 2.1.3.

2.2.61.1.13 On the basis of the criteria of 2.2.61.1.6 to 2.2.61.1.11, it may also be determined whether the nature of a solution or mixture mentioned by name or containing a substance mentioned by name is such that the solution or mixture is not subject to the requirements for this Class.

2.2.61.1.14 Substances, solutions and mixtures, with the exception of substances and preparations used as pesticides, which do not meet the criteria of Directives 67/548/EEC³ or 1999/45/EC⁴ as amended and which are not therefore classified as highly toxic, toxic or harmful according to these directives, as amended, may be considered as substances not belonging to Class 6.1.

2.2.61.2 Substances not accepted for carriage

2.2.61.2.1 Chemically unstable substances of Class 6.1 shall not be accepted for carriage unless the necessary steps have been taken to prevent their dangerous decomposition or polymerization during carriage. To this end, it shall in particular be ensured that receptacles and tanks do not contain any substance(s) likely to cause such a reaction.

2.2.61.2.2 The following substances and mixtures shall not be accepted for carriage:

- Hydrogen cyanide, anhydrous or in solution, which do not meet the descriptions of UN Nos. 1051, 1613, 1614 and 3294;
- metal carbonyls, having a flash-point below 23 °C, other than UN Nos. 1259 NICKEL CARBONYL and 1994 IRON PENTACARBONYL;
- 2,3,7,8-TETRACHLORODIBENZO-P-DIOXINE (TCDD) in concentrations considered highly toxic in accordance with the criteria in 2.2.61.1.7;
- UN No. 2249 DICHLORODIMETHYL ETHER, SYMMETRICAL;
- preparations of phosphides without additives inhibiting the emission of toxic flammable gases.

³ Council Directive 67/548/EEC of 27 June 1967 on the approximation of laws, regulations and administrative provisions relating to the classification, packaging and labelling of dangerous substances (Official Journal of the European Communities No. L 196 of 16.08.1967).

⁴ Directive 1999/45/EC of the European Parliament and of the Council of 31 May 1999 on the approximation of laws, regulations and administrative provisions of the Member States relating to the classification, packaging and labelling of dangerous preparations (Official Journal of the European Communities No. L 200 of 30 July 1999).

2.2.61.3 *List of collective entries***Toxic substances without subsidiary risk(s)**

Organic	liquid^a	T1	1583 CHLOROPICRIN MIXTURE, N.O.S. 1602 DYE, LIQUID, TOXIC, N.O.S., or 1602 DYE INTERMEDIATE, LIQUID, TOXIC, N.O.S. 1693 TEAR GAS SUBSTANCE, LIQUID, N.O.S. 1851 MEDICINE, LIQUID, TOXIC, N.O.S. 2206 ISOCYANATES, TOXIC, N.O.S. or 2206 ISOCYANATE SOLUTION, TOXIC, N.O.S. 3140 ALKALOIDS, LIQUID, N.O.S. or 3140 ALKALOID SALTS, LIQUID, N.O.S. 3142 DISINFECTANT, LIQUID, TOXIC, N.O.S. 3144 NICOTINE COMPOUND, LIQUID, N.O.S. or 3144 NICOTINE PREPARATION, LIQUID, N.O.S. 3172 TOXINS, EXTRACTED FROM LIVING SOURCES, LIQUID, N.O.S. 3276 NITRILES, TOXIC, LIQUID, N.O.S. 3278 ORGANOPHOSPHORUS COMPOUND, TOXIC, LIQUID, N.O.S. 3381 TOXIC BY INHALATION LIQUID, N.O.S. with an inhalation toxicity lower than or equal to 200 ml/m ³ and saturated vapour concentration greater than or equal to 500 LC ₅₀ 3382 TOXIC BY INHALATION LIQUID, N.O.S. with an inhalation toxicity lower than or equal to 1000 ml/m ³ and saturated vapour concentration greater than or equal to 10 LC ₅₀ 2810 TOXIC LIQUID, ORGANIC, N.O.S.
	solid^{a, b}	T2	1544 ALKALOIDS, SOLID, N.O.S. or 1544 ALKALOID SALTS, SOLID, N.O.S. 1601 DISINFECTANT, SOLID, TOXIC, N.O.S. 1655 NICOTINE COMPOUND, SOLID, N.O.S., or 1655 NICOTINE PREPARATION, SOLID, N.O.S. 3448 TEAR GAS SUBSTANCE, SOLID, N.O.S. 3143 DYE, SOLID, TOXIC, N.O.S. or 3143 DYE INTERMEDIATE, SOLID, TOXIC, N.O.S. 3462 TOXINS, EXTRACTED FROM LIVING SOURCES, SOLID, N.O.S. 3249 MEDICINE, SOLID, TOXIC, N.O.S. 3464 ORGANOPHOSPHORUS COMPOUND, TOXIC, SOLID, N.O.S. 3439 NITRILES, TOXIC, SOLID, N.O.S. 2811 TOXIC SOLID, ORGANIC, N.O.S.
Organometallic^{c, d}		T3	2026 PHENYLMERCURIC COMPOUND, N.O.S. 2788 ORGANOTIN COMPOUND, LIQUID, N.O.S. 3146 ORGANOTIN COMPOUND, SOLID, N.O.S. 3280 ORGANOARSENIC COMPOUND, LIQUID, N.O.S. 3465 ORGANOARSENIC COMPOUND, SOLID, N.O.S. 3281 METAL CARBONYLS, LIQUID, N.O.S. 3466 METAL CARBONYLS, SOLID, N.O.S. 3282 ORGANOMETALLIC COMPOUND, TOXIC, LIQUID, N.O.S. 3467 ORGANOMETALLIC COMPOUND, TOXIC, SOLID, N.O.S.

(cont'd on next page)

^a Substances and preparations containing alkaloids or nicotine used as pesticides shall be classified under UN No. 2588 PESTICIDES, SOLID, TOXIC, N.O.S., UN No. 2902 PESTICIDES, LIQUID, TOXIC, N.O.S. or UN No. 2903 PESTICIDES, LIQUID, TOXIC, FLAMMABLE, N.O.S.

^b Active substances and triturations or mixtures of substances intended for laboratories and experiments and for the manufacture of pharmaceutical products with other substances shall be classified according to their toxicity (see 2.2.61.1.7 to 2.2.61.1.11).

^c Self-heating substances, slightly toxic and spontaneously combustible organometallic compounds, are substances of Class 4.2.

^d Water-reactive substances, slightly toxic, and water-reactive organometallic compounds, are substances of Class 4.3.

2.2.61.3 *List of collective entries (cont'd)***Toxic substances without subsidiary risk(s) (cont'd)**

Inorganic	liquid^e T4	1556 ARSENIC COMPOUND, LIQUID, N.O.S., inorganic including: Arsenates, n.o.s., Arsenites, n.o.s.; and Arsenic sulphides, n.o.s. 1935 CYANIDE SOLUTION, N.O.S. 2024 MERCURY COMPOUND, LIQUID, N.O.S. 3141 ANTIMONY COMPOUND, INORGANIC, LIQUID, N.O.S. 3440 SELENIUM COMPOUND, LIQUID, N.O.S. 3381 TOXIC BY INHALATION LIQUID, N.O.S. with an inhalation toxicity lower than or equal to 200 ml/m ³ and saturated vapour concentration greater than or equal to 500 LC ₅₀ 3382 TOXIC BY INHALATION LIQUID, N.O.S. with an inhalation toxicity lower than or equal to 1000 ml/m ³ and saturated vapour concentration greater than or equal to 10 LC ₅₀ 3287 TOXIC LIQUID, INORGANIC, N.O.S.
	solids^{f,g} T5	1549 ANTIMONY COMPOUND, INORGANIC, SOLID, N.O.S. 1557 ARSENIC COMPOUND, SOLID, N.O.S., including: Arsenates, n.o.s.; Arsenites, n.o.s.; and Arsenic sulphides, n.o.s. 1564 BARIUM COMPOUND, N.O.S. 1566 BERYLLIUM COMPOUND, N.O.S. 1588 CYANIDES, INORGANIC, SOLID, N.O.S. 1707 THALLIUM COMPOUND, N.O.S. 2025 MERCURY COMPOUND, SOLID, N.O.S. 2291 LEAD COMPOUND, SOLUBLE, N.O.S. 2570 CADMIUM COMPOUND 2630 SELENATES or 2630 SELENITES 2856 FLUOROSILICATES, N.O.S. 3283 SELENIUM COMPOUND, SOLID, N.O.S. 3284 TELLURIUM COMPOUND, N.O.S. 3285 VANADIUM COMPOUND, N.O.S. 3288 TOXIC SOLID, INORGANIC, N.O.S.
	liquid^h T6	2992 CARBAMATE PESTICIDE, LIQUID, TOXIC 2994 ARSENICAL PESTICIDE, LIQUID, TOXIC 2996 ORGANOCHLORINE PESTICIDE, LIQUID, TOXIC 2998 TRIAZINE PESTICIDE, LIQUID, TOXIC 3006 THIOCARBAMATE PESTICIDE, LIQUID, TOXIC 3010 COPPER BASED PESTICIDE, LIQUID, TOXIC 3012 MERCURY BASED PESTICIDE, LIQUID, TOXIC 3014 SUBSTITUTED NITROPHENOL PESTICIDE, LIQUID, TOXIC 3016 BIPYRIDILIUM PESTICIDE, LIQUID, TOXIC 3018 ORGANOPHOSPHORUS PESTICIDE, LIQUID, TOXIC 3020 ORGANOTIN PESTICIDE, LIQUID, TOXIC 3026 COUMARIN DERIVATIVE PESTICIDE, LIQUID, TOXIC 3348 PHENOXYACETIC ACID DERIVATIVE PESTICIDE, LIQUID, TOXIC 3352 PYRETHROID PESTICIDE, LIQUID, TOXIC 2902 PESTICIDE, LIQUID, TOXIC, N.O.S.
Pesticides		
<i>(cont'd on next page)</i>		

^e Mercury fulminate, wetted with not less than 20% water, or mixture of alcohol and water by mass is a substance of Class 1, UN No. 0135.

^f Ferricyanides, ferrocyanides, alkaline thiocyanates and ammonium thiocyanates are not subject to the provisions of ADR.

^g Lead salts and lead pigments which, when mixed in a ratio of 1:1,000 with 0.07M hydrochloric acid and stirred for one hour at a temperature of 23 °C ± 2 °C, exhibit a solubility of 5% or less, are not subject to the provisions of ADR.

^h Articles impregnated with this pesticide, such as fibreboard plates, paper strips, cotton-wool balls, sheets of plastics material, in hermetically closed wrappings, are not subject to the provisions of ADR.

2.2.61.3 List of collective entries (cont'd)**Toxic substances without subsidiary risk(s) (cont'd)**

Pesticides (cont'd)		
Solid^h	T7	2757 CARBAMATE PESTICIDE, SOLID, TOXIC
		2759 ARSENICAL PESTICIDE, SOLID, TOXIC
		2761 ORGANOCHLORINE PESTICIDE, SOLID, TOXIC
		2763 TRIAZINE PESTICIDE, SOLID, TOXIC
		2771 THIOCARBAMATE PESTICIDE, SOLID, TOXIC
		2775 COPPER BASED PESTICIDE, SOLID, TOXIC
		2777 MERCURY BASED PESTICIDE, SOLID, TOXIC
		2779 SUBSTITUTED NITROPHENOL PESTICIDE, SOLID, TOXIC
		2781 BIPYRIDILIUM PESTICIDE, SOLID, TOXIC
		2783 ORGANOPHOSPHORUS PESTICIDE, SOLID, TOXIC
		2786 ORGANOTIN PESTICIDE, SOLID, TOXIC
		3027 COUMARIN DERIVATIVE PESTICIDE, SOLID, TOXIC
		3048 ALUMINIUM PHOSPHIDE PESTICIDE
		3345 PHENOXYACETIC ACID DERIVATIVE PESTICIDE, SOLID, TOXIC
		3349 PYRETHROID PESTICIDE, SOLID, TOXIC
	2588 PESTICIDE, SOLID, TOXIC, N.O.S.	
Samples		
	T8	3315 CHEMICAL SAMPLE, TOXIC
Other toxic substancesⁱ		
	T9	3243 SOLIDS CONTAINING TOXIC LIQUID, N.O.S.

Toxic substances with subsidiary risk(s)

Flammable	Liquid^{j,k}	TF1	3071 MERCAPTANS, LIQUID, TOXIC, FLAMMABLE, N.O.S. or
			3071 MERCAPTAN MIXTURE, LIQUID, TOXIC, FLAMMABLE, N.O.S.
			3080 ISOCYANATES, TOXIC, FLAMMABLE, N.O.S. or
			3080 ISOCYANATE SOLUTION, TOXIC, FLAMMABLE, N.O.S.
			3275 NITRILES, TOXIC, FLAMMABLE, N.O.S.
			3279 ORGANOPHOSPHORUS COMPOUND, TOXIC, FLAMMABLE, N.O.S.
			3383 TOXIC BY INHALATION LIQUID, FLAMMABLE, N.O.S. with an inhalation toxicity lower than or equal to 200 ml/m ³ and saturated vapour concentration greater than or equal to 500 LC ₅₀
			3384 TOXIC BY INHALATION LIQUID, FLAMMABLE, N.O.S. with an inhalation toxicity lower than or equal to 1000 ml/m ³ and saturated vapour concentration greater than or equal to 10 LC ₅₀
			2929 TOXIC LIQUID, FLAMMABLE, ORGANIC, N.O.S.

(cont'd on next page)

^h Articles impregnated with this pesticide, such as fibreboard plates, paper strips, cotton-wool balls, sheets of plastics material, in hermetically closed wrappings, are not subject to the provisions of ADR.

ⁱ Mixtures of solids which are not subject to the provisions of ADR and of toxic liquids may be carried under UN No. 3243 without first applying the classification criteria of Class 6.1, provided there is no free liquid visible at the time the substance is loaded or at the time the packaging, container or transport unit is closed. Each packaging shall correspond to a design type that has passed a leakproofness test at the packing group II level. This entry shall not be used for solids containing a packing group I liquid.

^j Highly toxic or toxic, flammable liquids having a flash-point below 23 °C excluding substances which are highly toxic on inhalation, i.e. UN Nos. 1051, 1092, 1098, 1143, 1163, 1182, 1185, 1238, 1239, 1244, 1251, 1259, 1613, 1614, 1695, 1994, 2334, 2382, 2407, 2438, 2480, 2482, 2484, 2485, 2606, 2929, 3279 and 3294 are substances of Class 3.

^k Flammable liquids, slightly toxic, with the exception of substances and preparations used as pesticides, having a flash-point between 23 °C and 60 °C inclusive, are substances of Class 3.

2.2.61.3 *List of collective entries (cont'd)**Toxic substances with subsidiary risk(s) (cont'd)*

Flammable TF (cont'd)	pesticides, liquid (flash-point not less than 23 °C)	TF2	2991 CARBAMATE PESTICIDE, LIQUID, TOXIC, FLAMMABLE
			2993 ARSENICAL PESTICIDE, LIQUID, TOXIC, FLAMMABLE
			2995 ORGANOCHLORINE PESTICIDE, LIQUID, TOXIC, FLAMMABLE
			2997 TRIAZINE PESTICIDE, LIQUID, TOXIC, FLAMMABLE
			3005 THIOCARBAMATE PESTICIDE, LIQUID, TOXIC, FLAMMABLE
			3009 COPPER BASED PESTICIDE, LIQUID, TOXIC, FLAMMABLE
			3011 MERCURY BASED PESTICIDE, LIQUID, TOXIC, FLAMMABLE
			3013 SUBSTITUTED NITROPHENOL PESTICIDE, LIQUID, TOXIC, FLAMMABLE
			3015 BIPYRIDILIUM PESTICIDE, LIQUID, TOXIC, FLAMMABLE
			3017 ORGANOPHOSPHORUS PESTICIDE, LIQUID, TOXIC, FLAMMABLE
			3019 ORGANOTIN PESTICIDE, LIQUID, TOXIC, FLAMMABLE
			3025 COUMARIN DERIVATIVE PESTICIDE, LIQUID, TOXIC, FLAMMABLE
			3347 PHENOXYACETIC ACID DERIVATIVE PESTICIDE, LIQUID, TOXIC, FLAMMABLE
			3351 PYRETHROID PESTICIDE, LIQUID, TOXIC, FLAMMABLE
			2903 PESTICIDE, LIQUID, TOXIC, FLAMMABLE, N.O.S.
	solid	TF3	1700 TEAR GAS CANDLES
			2930 TOXIC SOLID, FLAMMABLE, ORGANIC, N.O.S.
Solid, self-heating^c			3124 TOXIC SOLID, SELF-HEATING, N.O.S.
TS			
	liquid	TW1	3385 TOXIC BY INHALATION LIQUID, WATER-REACTIVE, N.O.S. with an inhalation toxicity lower than or equal to 200 ml/m ³ and saturated vapour concentration greater than or equal to 500 LC ₅₀
			3386 TOXIC BY INHALATION LIQUID, WATER-REACTIVE, N.O.S. with an inhalation toxicity lower than or equal to 1000 ml/m ³ and saturated vapour concentration greater than or equal to 10 LC ₅₀
			3123 TOXIC LIQUID, WATER-REACTIVE, N.O.S.
Water-reactive^d			
TW	solidⁿ	TW2	3125 TOXIC SOLID, WATER-REACTIVE, N.O.S.
	liquid	TO1	3387 TOXIC BY INHALATION LIQUID, OXIDIZING, N.O.S. with an inhalation toxicity lower than or equal to 200 ml/m ³ and saturated vapour concentration greater than or equal to 500 LC ₅₀
			3388 TOXIC BY INHALATION LIQUID, OXIDIZING, N.O.S. with an inhalation toxicity lower than or equal to 1000 ml/m ³ and saturated vapour concentration greater than or equal to 10 LC ₅₀
			3122 TOXIC LIQUID, OXIDIZING, N.O.S.
Oxidizing^l			
TO	solid	TO2	3086 TOXIC SOLID, OXIDIZING, N.O.S.
	liquid	TC1	3277 CHLOROFORMATES, TOXIC, CORROSIVE, N.O.S.
			3361 CHLOROSILANES, TOXIC, CORROSIVE, N.O.S.
			3389 TOXIC BY INHALATION LIQUID, CORROSIVE, N.O.S. with an inhalation toxicity lower than or equal to 200 ml/m ³ and saturated vapour concentration greater than or equal to 500 LC ₅₀
			3390 TOXIC BY INHALATION LIQUID, CORROSIVE, N.O.S. with an inhalation toxicity lower than or equal to 1000 ml/m ³ and saturated vapour concentration greater than or equal to 10 LC ₅₀
			2927 TOXIC LIQUID, CORROSIVE, ORGANIC, N.O.S.
Corrosive^m	organic		
TC	solid	TC2	2928 TOXIC SOLID, CORROSIVE, ORGANIC, N.O.S.

(cont'd on next page)

^c Self-heating substances, slightly toxic and spontaneously combustible organometallic compounds, are substances of Class 4.2.

^d Water-reactive substances, slightly toxic, and water-reactive organometallic compounds, are substances of Class 4.3.

^l Oxidizing substances, slightly toxic, are substances of Class 5.1.

^m Substances slightly toxic and slightly corrosive, are substances of Class 8.

ⁿ Metal phosphides assigned to UN Nos. 1360, 1397, 1432, 1714, 2011 and 2013 are substances of Class 4.3.

2.2.61.3 *List of collective entries (cont'd)***Toxic substances with subsidiary risk(s) (cont'd)**

Corrosive^m			
TC (cont'd)	inorganic	liquid	TC3
			3389 TOXIC BY INHALATION LIQUID, CORROSIVE, N.O.S. with an inhalation toxicity lower than or equal to 200 ml/m ³ and saturated vapour concentration greater than or equal to 500 LC ₅₀
			3390 TOXIC BY INHALATION LIQUID, CORROSIVE, N.O.S. with an inhalation toxicity lower than or equal to 1000 ml/m ³ and saturated vapour concentration greater than or equal to 10 LC ₅₀
		3289 TOXIC LIQUID, CORROSIVE, INORGANIC, N.O.S.	
	solid	TC4	3290 TOXIC SOLID, CORROSIVE, INORGANIC, N.O.S.
Flammable, corrosive			
TFC			2742 CHLOROFORMATES, TOXIC, CORROSIVE, FLAMMABLE, N.O.S.
			3362 CHLOROSILANES, TOXIC, CORROSIVE, FLAMMABLE, N.O.S.
			3488 TOXIC BY INHALATION LIQUID, FLAMMABLE, CORROSIVE, N.O.S. with an inhalation toxicity lower than or equal to 200 ml/m ³ and saturated vapour concentration greater than or equal to 500 LC ₅₀
			3489 TOXIC BY INHALATION LIQUID, FLAMMABLE, CORROSIVE, N.O.S. with an inhalation toxicity lower than or equal to 1000 ml/m ³ and saturated vapour concentration greater than or equal to 10 LC ₅₀
			3492 TOXIC BY INHALATION LIQUID, CORROSIVE, FLAMMABLE, N.O.S. with an inhalation toxicity lower than or equal to 200 ml/m ³ and saturated vapour concentration greater than or equal to 500 LC ₅₀
			3493 TOXIC BY INHALATION LIQUID, CORROSIVE, FLAMMABLE, N.O.S. with an inhalation toxicity lower than or equal to 1000 ml/m ³ and saturated vapour concentration greater than or equal to 10 LC ₅₀
Flammable, water-reactive			
TFW			3490 TOXIC BY INHALATION LIQUID, WATER-REACTIVE, FLAMMABLE, N.O.S. with an inhalation toxicity lower than or equal to 200 ml/m ³ and saturated vapour concentration greater than or equal to 500 LC ₅₀
			3491 TOXIC BY INHALATION LIQUID, WATER-REACTIVE, FLAMMABLE, N.O.S. with an inhalation toxicity lower than or equal to 1000 ml/m ³ and saturated vapour concentration greater than or equal to 10 LC ₅₀

^m Substances slightly toxic and slightly corrosive, are substances of Class 8.

2.2.62 Class 6.2 Infectious substances

2.2.62.1 Criteria

2.2.62.1.1 The heading of Class 6.2 covers infectious substances. For the purposes of ADR, infectious substances are substances which are known or are reasonably expected to contain pathogens. Pathogens are defined as microorganisms (including bacteria, viruses, rickettsiae, parasites, fungi) and other agents such as prions, which can cause disease in humans or animals.

NOTE 1: Genetically modified microorganisms and organisms, biological products, diagnostic specimens and infected live animals shall be assigned to this Class if they meet the conditions for this class.

NOTE 2: Toxins from plant, animal or bacterial sources which do not contain any infectious substances or organisms or which are not contained in them are substances of Class 6.1, UN Nos. 3172 or 3462.

2.2.62.1.2 Substances of Class 6.2 are subdivided as follows:

- I1 Infectious substances affecting humans;
- I2 Infectious substances affecting animals only;
- I3 Clinical waste;
- I4 Biological substances.

Definitions

2.2.62.1.3 For the purposes of ADR,

"Biological products" are those products derived from living organisms which are manufactured and distributed in accordance with the requirements of appropriate national authorities, which may have special licensing requirements, and are used either for prevention, treatment, or diagnosis of disease in humans or animals, or for development, experimental or investigational purposes related thereto. They include, but are not limited to, finished or unfinished products such as vaccines;

"Cultures" are the result of a process by which pathogens are intentionally propagated. This definition does not include human or animal patient specimens as defined in this paragraph;

"Medical or clinical wastes" are wastes derived from the medical treatment of animals or humans or from bio-research;

"Patient specimens" are human or animal materials, collected directly from humans or animals, including, but not limited to, excreta, secreta, blood and its components, tissue and tissue fluid swabs, and body parts being carried for purposes such as research, diagnosis, investigational activities, disease treatment and prevention.

Classification

2.2.62.1.4 Infectious substances shall be classified in Class 6.2 and assigned to UN Nos. 2814, 2900, 3291 or 3373, as appropriate.

Infectious substances are divided into the following categories:

2.2.62.1.4.1 Category A: An infectious substance which is carried in a form that, when exposure to it occurs, is capable of causing permanent disability, life-threatening or fatal disease in otherwise healthy humans or animals. Indicative examples of substances that meet these criteria are given in the table in this paragraph.

NOTE: An exposure occurs when an infectious substance is released outside of the protective packaging, resulting in physical contact with humans or animals.

- (a) Infectious substances meeting these criteria which cause disease in humans or both in humans and animals shall be assigned to UN No. 2814. Infectious substances which cause disease only in animals shall be assigned to UN No. 2900;
- (b) Assignment to UN No. 2814 or UN No. 2900 shall be based on the known medical history and symptoms of the source human or animal, endemic local conditions, or professional judgement concerning individual circumstances of the source human or animal.

NOTE 1: The proper shipping name for UN No. 2814 is "INFECTIOUS SUBSTANCE, AFFECTING HUMANS". The proper shipping name for UN No. 2900 is "INFECTIOUS SUBSTANCE, AFFECTING ANIMALS only".

NOTE 2: The following table is not exhaustive. Infectious substances, including new or emerging pathogens, which do not appear in the table but which meet the same criteria shall be assigned to Category A. In addition, if there is doubt as to whether or not a substance meets the criteria it shall be included in Category A.

NOTE 3: In the following table, the microorganisms written in italics are bacteria, mycoplasmas, rickettsia or fungi.

**INDICATIVE EXAMPLES OF INFECTIOUS SUBSTANCES INCLUDED IN CATEGORY A
IN ANY FORM UNLESS OTHERWISE INDICATED**

(2.2.62.1.4.1)

UN Number and name	Microorganism
UN No. 2814 Infectious substances affecting humans	<i>Bacillus anthracis (cultures only)</i> <i>Brucella abortus (cultures only)</i> <i>Brucella melitensis (cultures only)</i> <i>Brucella suis (cultures only)</i> <i>Burkholderia mallei - Pseudomonas mallei – Glanders (cultures only)</i> <i>Burkholderia pseudomallei – Pseudomonas pseudomallei (cultures only)</i> <i>Chlamydia psittaci - avian strains (cultures only)</i> <i>Clostridium botulinum (cultures only)</i> <i>Coccidioides immitis (cultures only)</i> <i>Coxiella burnetii (cultures only)</i> Crimean-Congo haemorrhagic fever virus Dengue virus (cultures only) Eastern equine encephalitis virus (cultures only) <i>Escherichia coli, verotoxigenic (cultures only)</i> ^a Ebola virus Flexal virus <i>Francisella tularensis (cultures only)</i> Guanarito virus Hantaan virus Hantavirus causing haemorrhagic fever with renal syndrome Hendra virus Hepatitis B virus (cultures only) Herpes B virus (cultures only) Human immunodeficiency virus (cultures only) Highly pathogenic avian influenza virus (cultures only) Japanese Encephalitis virus (cultures only) Junin virus Kysanur Forest disease virus Lassa virus Machupo virus Marburg virus Monkeypox virus <i>Mycobacterium tuberculosis (cultures only)</i> ^a Nipah virus Omsk haemorrhagic fever virus Poliovirus (cultures only) Rabies virus (cultures only) <i>Rickettsia prowazekii (cultures only)</i> <i>Rickettsia rickettsii (cultures only)</i> Rift Valley fever virus (cultures only) Russian spring-summer encephalitis virus (cultures only) Sabia virus <i>Shigella dysenteriae type 1 (cultures only)</i> ^a Tick-borne encephalitis virus (cultures only) Variola virus Venezuelan equine encephalitis virus (cultures only) West Nile virus (cultures only) Yellow fever virus (cultures only) <i>Yersinia pestis (cultures only)</i>

^a Nevertheless, when the cultures are intended for diagnostic or clinical purposes, they may be classified as infectious substances of Category B.

**INDICATIVE EXAMPLES OF INFECTIOUS SUBSTANCES INCLUDED IN CATEGORY A
IN ANY FORM UNLESS OTHERWISE INDICATED
(2.2.62.1.4.1)**

UN Number and name	Microorganism
UN No. 2900 Infectious substances affecting animals only	African swine fever virus (cultures only) Avian paramyxovirus Type 1 - Velogenic Newcastle disease virus (cultures only) Classical swine fever virus (cultures only) Foot and mouth disease virus (cultures only) Lumpy skin disease virus (cultures only) <i>Mycoplasma mycoides</i> - Contagious bovine pleuropneumonia (cultures only) Peste des petits ruminants virus (cultures only) Rinderpest virus (cultures only) Sheep-pox virus (cultures only) Goatpox virus (cultures only) Swine vesicular disease virus (cultures only) Vesicular stomatitis virus (cultures only)

2.2.62.1.4.2 Category B: An infectious substance which does not meet the criteria for inclusion in Category A. Infectious substances in Category B shall be assigned to UN No. 3373.

NOTE: The proper shipping name of UN No. 3373 is "BIOLOGICAL SUBSTANCE, CATEGORY B".

2.2.62.1.5 *Exemptions*

2.2.62.1.5.1 Substances which do not contain infectious substances or substances which are unlikely to cause disease in humans or animals are not subject to the provisions of ADR unless they meet the criteria for inclusion in another class.

2.2.62.1.5.2 Substances containing microorganisms which are non-pathogenic to humans or animals are not subject to ADR unless they meet the criteria for inclusion in another class.

2.2.62.1.5.3 Substances in a form that any present pathogens have been neutralized or inactivated such that they no longer pose a health risk are not subject to ADR unless they meet the criteria for inclusion in another class.

2.2.62.1.5.4 Substances where the concentration of pathogens is at a level naturally encountered (including foodstuff and water samples) and which are not considered to pose a significant risk of infection are not subject to ADR unless they meet the criteria for inclusion in another class.

2.2.62.1.5.5 Dried blood spots, collected by applying a drop of blood onto absorbent material, or faecal occult blood screening tests and blood or blood components which have been collected for the purposes of transfusion or for the preparation of blood products to be used for transfusion or transplantation and any tissues or organs intended for use in transplantation are not subject to the provisions of ADR.

2.2.62.1.5.6 Human or animal specimens for which there is minimal likelihood that pathogens are present are not subject to ADR if the specimen is carried in a packaging which will prevent any leakage and which is marked with the words "Exempt human specimen" or "Exempt animal specimen", as appropriate.

The packaging is deemed to comply with the above requirements if it meets the following conditions:

- (a) The packaging consists of three components:
 - (i) a leak-proof primary receptacle(s);
 - (ii) a leak-proof secondary packaging; and
 - (iii) an outer packaging of adequate strength for its capacity, mass and intended use, and with at least one surface having minimum dimensions of 100 mm × 100 mm;
- (b) For liquids, absorbent material in sufficient quantity to absorb the entire contents is placed between the primary receptacle(s) and the secondary packaging so that, during carriage, any release or leak of a liquid substance will not reach the outer packaging and will not compromise the integrity of the cushioning material;
- (c) When multiple fragile primary receptacles are placed in a single secondary packaging, they are either individually wrapped or separated to prevent contact between them.

NOTE 1: *An element of professional judgment is required to determine if a substance is exempt under this paragraph. That judgment should be based on the known medical history, symptoms and individual circumstances of the source, human or animal, and endemic local conditions. Examples of specimens which may be carried under this paragraph include the blood or urine tests to monitor cholesterol levels, blood glucose levels, hormone levels, or prostate specific antibodies (PSA); those required to monitor organ function such as heart, liver or kidney function for humans or animals with non-infectious diseases, or for therapeutic drug monitoring; those conducted for insurance or employment purposes and are intended to determine the presence of drugs or alcohol; pregnancy test; biopsies to detect cancer; and antibody detection in humans or animals in the absence of any concern for infection (e.g. evaluation of vaccine induced immunity, diagnosis of autoimmune disease, etc.).*

NOTE 2: *For air transport, packagings for specimens exempted under this paragraph shall meet the conditions in (a) to (c).*

2.2.62.1.6 to 2.2.62.1.8 (Reserved)

2.2.62.1.9 *Biological products*

For the purposes of ADR, biological products are divided into the following groups:

- (a) those which are manufactured and packaged in accordance with the requirements of appropriate national authorities and carried for the purposes of final packaging or distribution, and use for personal health care by medical professionals or individuals. Substances in this group are not subject to the provisions of ADR;
- (b) those which do not fall under paragraph (a) and are known or reasonably believed to contain infectious substances and which meet the criteria for inclusion in Category A or Category B. Substances in this group shall be assigned to UN Nos. 2814, 2900 or 3373, as appropriate.

NOTE: *Some licensed biological products may present a biohazard only in certain parts of the world. In that case, competent authorities may require these biological products to be in compliance with local requirements for infectious substances or may impose other restrictions.*

2.2.62.1.10 *Genetically modified microorganisms and organisms*

Genetically modified microorganisms not meeting the definition of infectious substance shall be classified according to section 2.2.9.

2.2.62.1.11 *Medical or clinical wastes*

- 2.2.62.1.11.1 Medical or clinical wastes containing Category A infectious substances shall be assigned to UN No. 2814 or UN No. 2900 as appropriate. Medical or clinical wastes containing infectious substances in Category B shall be assigned to UN No. 3291.

NOTE: *Medical or clinical wastes assigned to number 18 01 03 (Wastes from human or animal health care and/or related research – wastes from natal care, diagnosis, treatment or prevention of disease in humans – wastes whose collection and disposal is subject to special requirements in order to prevent infection) or 18 02 02 (Wastes from human or animal health care and/or related research – wastes from research, diagnosis, treatment or prevention of disease involving animals – wastes whose collection and disposal is subject to special requirements in order to prevent infection) according to the list of wastes annexed to the Commission Decision 2000/532/EC⁵ as amended, shall be classified according to the provisions set out in this paragraph, based on the medical or veterinary diagnosis concerning the patient or the animal.*

- 2.2.62.1.11.2 Medical or clinical wastes which are reasonably believed to have a low probability of containing infectious substances shall be assigned to UN No. 3291. For the assignment, international, regional or national waste catalogues may be taken into account.

NOTE 1: *The proper shipping name for UN No. 3291 is "CLINICAL WASTE, UNSPECIFIED, N.O.S." or "(BIO) MEDICAL WASTE, N.O.S". or "REGULATED MEDICAL WASTE, N.O.S".*

NOTE 2: *Notwithstanding the classification criteria set out above, medical or clinical wastes assigned to number 18 01 04 (Wastes from human or animal health care and/or related research – wastes from natal care, diagnosis, treatment or prevention of disease in humans – wastes whose collection and disposal is not subject to special requirements in order to prevent infection) or 18 02 03 (Wastes from human or animal health care and/or related research – wastes from research, diagnosis, treatment or prevention of disease involving animals – wastes whose collection and disposal is not subject to special requirements in order to prevent infection) according to the list of wastes annexed to the Commission Decision 2000/532/EC⁵ as amended, are not subject to the provisions of ADR.*

- 2.2.62.1.11.3 Decontaminated medical or clinical wastes which previously contained infectious substances are not subject to the provisions of ADR unless they meet the criteria for inclusion in another class.

- 2.2.62.1.11.4 Medical or clinical wastes assigned to UN No. 3291 are assigned to packing group II.

⁵ *Commission Decision 2000/532/EC of 3 May 2000 replacing Decision 94/3/EC establishing a list of wastes pursuant to Article 1(a) of Council Directive 75/442/EEC on waste (replaced by the Directive 2006/12/EC of the European Parliament and of the Council (Official Journal of the European Union No. L 114 of 27 April 2006, page 9)) and Council Decision 94/904/EC establishing a list of hazardous waste pursuant to Article 1(4) of Council Directive 91/689/EEC on hazardous waste (Official Journal of the European Communities No. L 226 of 6 September 2000, page 3).*

2.2.62.1.12 *Infected animals*

2.2.62.1.12.1 Unless an infectious substance cannot be consigned by any other means, live animals shall not be used to consign such a substance. A live animal which has been intentionally infected and is known or suspected to contain an infectious substance shall only be carried under terms and conditions approved by the competent authority ⁶.

2.2.62.1.12.2 Animal material affected by pathogens of Category A or by pathogens which would be assigned to Category A in cultures only, shall be assigned to UN 2814 or UN 2900 as appropriate. Animal material affected by pathogens of Category B, other than those which would be assigned to Category A if they were in cultures, shall be assigned to UN 3373.

2.2.62.2 *Substances not accepted for carriage*

Live vertebrate or invertebrate animals shall not be used to carry an infectious agent unless the agent cannot be carried by other means or unless this carriage has been approved by the competent authority (see 2.2.62.1.12.1).

2.2.62.3 *List of collective entries*

Effects on humans	I1	2814 INFECTIOUS SUBSTANCE, AFFECTING HUMANS
Effects on animals only	I2	2900 INFECTIOUS SUBSTANCE, AFFECTING ANIMALS only
Clinical waste	I3	3291 CLINICAL WASTE, UNSPECIFIED, N.O.S. or 3291 (BIO) MEDICAL WASTE, N.O.S. or 3291 REGULATED MEDICAL WASTE, N.O.S.
Biological substances	I4	3373 BIOLOGICAL SUBSTANCE, CATEGORY B

⁶ Regulations governing the carriage of live animals are contained in, e.g. Directive 91/628/EEC of 19 November 1991 on the protection of animals during transport (Official Journal of the European Communities No. L 340 of 11.12.1991, p.17) and in the Recommendations of the Council of Europe (Ministerial Committee) on the carriage of certain animal species.

2.2.7 **Class 7 Radioactive material**

2.2.7.1 **Definitions**

2.2.7.1.1 *Radioactive material* means any material containing radionuclides where both the activity concentration and the total activity in the consignment exceed the values specified in 2.2.7.2.2.1 to 2.2.7.2.2.6.

2.2.7.1.2 *Contamination*

Contamination means the presence of a radioactive substance on a surface in quantities in excess of 0.4 Bq/cm² for beta and gamma emitters and low toxicity alpha emitters, or 0.04 Bq/cm² for all other alpha emitters.

Non-fixed contamination means contamination that can be removed from a surface during routine conditions of carriage.

Fixed contamination means contamination other than non-fixed contamination.

2.2.7.1.3 *Definitions of specific terms*

A_1 and A_2

A_1 means the activity value of special form radioactive material which is listed in the Table in 2.2.7.2.2.1 or derived in 2.2.7.2.2.2 and is used to determine the activity limits for the requirements of ADR.

A_2 means the activity value of radioactive material, other than special form radioactive material, which is listed in the Table in 2.2.7.2.2.1 or derived in 2.2.7.2.2.2 and is used to determine the activity limits for the requirements of ADR.

Fissile nuclides means uranium-233, uranium-235, plutonium-239 and plutonium-241. *Fissile material* means a material containing any of the fissile nuclides. Excluded from the definition of fissile material are:

- (a) Natural uranium or depleted uranium which is unirradiated; and
- (b) Natural uranium or depleted uranium which has been irradiated in thermal reactors only.

Low dispersible radioactive material means either a solid radioactive material or a solid radioactive material in a sealed capsule, that has limited dispersibility and is not in powder form.

Low specific activity (LSA) material means radioactive material which by its nature has a limited specific activity, or radioactive material for which limits of estimated average specific activity apply. External shielding materials surrounding the LSA material shall not be considered in determining the estimated average specific activity.

Low toxicity alpha emitters are: natural uranium; depleted uranium; natural thorium; uranium-235 or uranium-238; thorium-232; thorium-228 and thorium-230 when contained in ores or physical and chemical concentrates; or alpha emitters with a half-life of less than 10 days.

Special form radioactive material means either:

- (a) An indispersible solid radioactive material; or
- (b) A sealed capsule containing radioactive material.

Specific activity of a radionuclide means the activity per unit mass of that nuclide. The specific activity of a material shall mean the activity per unit mass of the material in which the radionuclides are essentially uniformly distributed.

Surface contaminated object (SCO) means a solid object which is not itself radioactive but which has radioactive material distributed on its surfaces.

Unirradiated thorium means thorium containing not more than 10^{-7} g of uranium-233 per gram of thorium-232.

Unirradiated uranium means uranium containing not more than 2×10^3 Bq of plutonium per gram of uranium-235, not more than 9×10^6 Bq of fission products per gram of uranium-235 and not more than 5×10^{-3} g of uranium-236 per gram of uranium-235.

Uranium - natural, depleted, enriched means the following:

Natural uranium means uranium (which may be chemically separated) containing the naturally occurring distribution of uranium isotopes (approximately 99.28% uranium-238, and 0.72% uranium-235 by mass).

Depleted uranium means uranium containing a lesser mass percentage of uranium-235 than in natural uranium.

Enriched uranium means uranium containing a greater mass percentage of uranium-235 than 0.72%.

In all cases, a very small mass percentage of uranium-234 is present.

2.2.7.2 Classification

2.2.7.2.1 General provisions

- 2.2.7.2.1.1 Radioactive material shall be assigned to one of the UN number specified in Table 2.2.7.2.1.1 depending on the activity level of the radionuclides contained in a package, the fissile or non fissile properties of these radionuclides, the type of package to be presented for carriage, and the nature or form of the contents of the package, or special arrangements governing the carriage operation, in accordance with the provisions laid down in 2.2.7.2.2 to 2.2.7.2.5.

Table 2.2.7.2.1.1 Assignment of UN numbers

Excepted packages (1.7.1.5)	
UN 2908	RADIOACTIVE MATERIAL, EXCEPTED PACKAGE - EMPTY PACKAGING
UN 2909	RADIOACTIVE MATERIAL, EXCEPTED PACKAGE - ARTICLES MANUFACTURED FROM NATURAL URANIUM or DEPLETED URANIUM or NATURAL THORIUM
UN 2910	RADIOACTIVE MATERIAL, EXCEPTED PACKAGE - LIMITED QUANTITY OF MATERIAL
UN 2911	RADIOACTIVE MATERIAL, EXCEPTED PACKAGE - INSTRUMENTS or ARTICLES
Low specific activity radioactive material (2.2.7.2.3.1)	
UN 2912	RADIOACTIVE MATERIAL, LOW SPECIFIC ACTIVITY (LSA-I), non fissile or fissile-excepted
UN 3321	RADIOACTIVE MATERIAL, LOW SPECIFIC ACTIVITY (LSA-II), non fissile or fissile-excepted
UN 3322	RADIOACTIVE MATERIAL, LOW SPECIFIC ACTIVITY (LSA-III), non fissile or fissile-excepted
UN 3324	RADIOACTIVE MATERIAL, LOW SPECIFIC ACTIVITY (LSA-II), FISSILE
UN 3325	RADIOACTIVE MATERIAL, LOW SPECIFIC ACTIVITY, (LSA-III), FISSILE
Surface contaminated objects (2.2.7.2.3.2)	
UN 2913	RADIOACTIVE MATERIAL, SURFACE CONTAMINATED OBJECTS (SCO-I or SCO-II), non fissile or fissile-excepted
UN 3326	RADIOACTIVE MATERIAL, SURFACE CONTAMINATED OBJECTS (SCO-I or SCO-II), FISSILE
Type A packages (2.2.7.2.4.4)	
UN 2915	RADIOACTIVE MATERIAL, TYPE A PACKAGE, non-special form, non fissile or fissile-excepted
UN 3327	RADIOACTIVE MATERIAL, TYPE A PACKAGE, FISSILE, non-special form
UN 3332	RADIOACTIVE MATERIAL, TYPE A PACKAGE, SPECIAL FORM, non fissile or fissile-excepted
UN 3333	RADIOACTIVE MATERIAL, TYPE A PACKAGE, SPECIAL FORM, FISSILE
Type B(U) packages (2.2.7.2.4.6)	
UN 2916	RADIOACTIVE MATERIAL, TYPE B(U) PACKAGE, non fissile or fissile-excepted
UN 3328	RADIOACTIVE MATERIAL, TYPE B(U) PACKAGE, FISSILE
Type B(M) packages (2.2.7.2.4.6)	
UN 2917	RADIOACTIVE MATERIAL, TYPE B(M) PACKAGE, non fissile or fissile-excepted
UN 3329	RADIOACTIVE MATERIAL, TYPE B(M) PACKAGE, FISSILE
Type C packages (2.2.7.2.4.6)	
UN 3323	RADIOACTIVE MATERIAL, TYPE C PACKAGE, non fissile or fissile-excepted
UN 3330	RADIOACTIVE MATERIAL, TYPE C PACKAGE, FISSILE
Special arrangement (2.2.7.2.5)	
UN 2919	RADIOACTIVE MATERIAL, TRANSPORTED UNDER SPECIAL ARRANGEMENT, non fissile or fissile-excepted
UN 3331	RADIOACTIVE MATERIAL, TRANSPORTED UNDER SPECIAL ARRANGEMENT, FISSILE
Uranium hexafluoride (2.2.7.2.4.5)	
UN 2977	RADIOACTIVE MATERIAL, URANIUM HEXAFLUORIDE, FISSILE
UN 2978	RADIOACTIVE MATERIAL, URANIUM HEXAFLUORIDE, non fissile or fissile- excepted

2.2.7.2.2 *Determination of activity level*

2.2.7.2.2.1 The following basic values for individual radionuclides are given in Table 2.2.7.2.2.1:

- (a) A_1 and A_2 in TBq;
- (b) Activity concentration for exempt material in Bq/g; and
- (c) Activity limits for exempt consignments in Bq.

Table 2.2.7.2.2.1: Basic radionuclides values for individual radionuclides

Radionuclide (atomic number)	A_1 (TBq)	A_2 (TBq)	Activity concentration for exempt material (Bq/g)	Activity limit for an exempt consignment (Bq)
Actinium (89)				
Ac-225 (a)	8×10^{-1}	6×10^{-3}	1×10^1	1×10^4
Ac-227 (a)	9×10^{-1}	9×10^{-5}	1×10^{-1}	1×10^3
Ac-228	6×10^{-1}	5×10^{-1}	1×10^1	1×10^6
Silver (47)				
Ag-105	2×10^0	2×10^0	1×10^2	1×10^6
Ag-108m (a)	7×10^{-1}	7×10^{-1}	1×10^1 (b)	1×10^6 (b)
Ag-110m (a)	4×10^{-1}	4×10^{-1}	1×10^1	1×10^6
Ag-111	2×10^0	6×10^{-1}	1×10^3	1×10^6
Aluminium (13)				
Al-26	1×10^{-1}	1×10^{-1}	1×10^1	1×10^5
Americium (95)				
Am-241	1×10^1	1×10^{-3}	1×10^0	1×10^4
Am-242m (a)	1×10^1	1×10^{-3}	1×10^0 (b)	1×10^4 (b)
Am-243 (a)	5×10^0	1×10^{-3}	1×10^0 (b)	1×10^3 (b)
Argon (18)				
Ar-37	4×10^1	4×10^1	1×10^6	1×10^8
Ar-39	4×10^1	2×10^1	1×10^7	1×10^4
Ar-41	3×10^{-1}	3×10^{-1}	1×10^2	1×10^9
Arsenic (33)				
As-72	3×10^{-1}	3×10^{-1}	1×10^1	1×10^5
As-73	4×10^1	4×10^1	1×10^3	1×10^7
As-74	1×10^0	9×10^{-1}	1×10^1	1×10^6

Radionuclide (atomic number)	A₁ (TBq)	A₂ (TBq)	Activity concentration for exempt material (Bq/g)	Activity limit for an exempt consignment (Bq)
As-76	3×10^{-1}	3×10^{-1}	1×10^2	1×10^5
As-77	2×10^1	7×10^{-1}	1×10^3	1×10^6
Astatine (85)				
At-211 (a)	2×10^1	5×10^{-1}	1×10^3	1×10^7
Gold (79)				
Au-193	7×10^0	2×10^0	1×10^2	1×10^7
Au-194	1×10^0	1×10^0	1×10^1	1×10^6
Au-195	1×10^1	6×10^0	1×10^2	1×10^7
Au-198	1×10^0	6×10^{-1}	1×10^2	1×10^6
Au-199	1×10^1	6×10^{-1}	1×10^2	1×10^6
Barium (56)				
Ba-131 (a)	2×10^0	2×10^0	1×10^2	1×10^6
Ba-133	3×10^0	3×10^0	1×10^2	1×10^6
Ba-133m	2×10^1	6×10^{-1}	1×10^2	1×10^6
Ba-140 (a)	5×10^{-1}	3×10^{-1}	1×10^1 (b)	1×10^5 (b)
Beryllium (4)				
Be-7	2×10^1	2×10^1	1×10^3	1×10^7
Be-10	4×10^1	6×10^{-1}	1×10^4	1×10^6
Bismuth (83)				
Bi-205	7×10^{-1}	7×10^{-1}	1×10^1	1×10^6
Bi-206	3×10^{-1}	3×10^{-1}	1×10^1	1×10^5
Bi-207	7×10^{-1}	7×10^{-1}	1×10^1	1×10^6
Bi-210	1×10^0	6×10^{-1}	1×10^3	1×10^6
Bi-210m (a)	6×10^{-1}	2×10^{-2}	1×10^1	1×10^5
Bi-212 (a)	7×10^{-1}	6×10^{-1}	1×10^1 (b)	1×10^5 (b)
Berkelium (97)				
Bk-247	8×10^0	8×10^{-4}	1×10^0	1×10^4
Bk-249 (a)	4×10^1	3×10^{-1}	1×10^3	1×10^6
Bromine (35)				
Br-76	4×10^{-1}	4×10^{-1}	1×10^1	1×10^5
Br-77	3×10^0	3×10^0	1×10^2	1×10^6

Radionuclide (atomic number)	A₁ (TBq)	A₂ (TBq)	Activity concentration for exempt material (Bq/g)	Activity limit for an exempt consignment (Bq)
Br-82	4×10^{-1}	4×10^{-1}	1×10^1	1×10^6
Carbon (6)				
C-11	1×10^0	6×10^{-1}	1×10^1	1×10^6
C-14	4×10^1	3×10^0	1×10^4	1×10^7
Calcium (20)				
Ca-41	Unlimited	Unlimited	1×10^5	1×10^7
Ca-45	4×10^1	1×10^0	1×10^4	1×10^7
Ca-47 (a)	3×10^0	3×10^{-1}	1×10^1	1×10^6
Cadmium (48)				
Cd-109	3×10^1	2×10^0	1×10^4	1×10^6
Cd-113m	4×10^1	5×10^{-1}	1×10^3	1×10^6
Cd-115 (a)	3×10^0	4×10^{-1}	1×10^2	1×10^6
Cd-115m	5×10^{-1}	5×10^{-1}	1×10^3	1×10^6
Cerium (58)				
Ce-139	7×10^0	2×10^0	1×10^2	1×10^6
Ce-141	2×10^1	6×10^{-1}	1×10^2	1×10^7
Ce-143	9×10^{-1}	6×10^{-1}	1×10^2	1×10^6
Ce-144 (a)	2×10^{-1}	2×10^{-1}	1×10^2 (b)	1×10^5 (b)
Californium (98)				
Cf-248	4×10^1	6×10^{-3}	1×10^1	1×10^4
Cf-249	3×10^0	8×10^{-4}	1×10^0	1×10^3
Cf-250	2×10^1	2×10^{-3}	1×10^1	1×10^4
Cf-251	7×10^0	7×10^{-4}	1×10^0	1×10^3
Cf-252	1×10^{-1}	3×10^{-3}	1×10^1	1×10^4
Cf-253 (a)	4×10^1	4×10^{-2}	1×10^2	1×10^5
Cf-254	1×10^{-3}	1×10^{-3}	1×10^0	1×10^3
Chlorine (17)				
Cl-36	1×10^1	6×10^{-1}	1×10^4	1×10^6
Cl-38	2×10^{-1}	2×10^{-1}	1×10^1	1×10^5

Radionuclide (atomic number)	A₁ (TBq)	A₂ (TBq)	Activity concentration for exempt material (Bq/g)	Activity limit for an exempt consignment (Bq)
Curium (96)				
Cm-240	4×10^1	2×10^{-2}	1×10^2	1×10^5
Cm-241	2×10^0	1×10^0	1×10^2	1×10^6
Cm-242	4×10^1	1×10^{-2}	1×10^2	1×10^5
Cm-243	9×10^0	1×10^{-3}	1×10^0	1×10^4
Cm-244	2×10^1	2×10^{-3}	1×10^1	1×10^4
Cm-245	9×10^0	9×10^{-4}	1×10^0	1×10^3
Cm-246	9×10^0	9×10^{-4}	1×10^0	1×10^3
Cm-247 (a)	3×10^0	1×10^{-3}	1×10^0	1×10^4
Cm-248	2×10^{-2}	3×10^{-4}	1×10^0	1×10^3
Cobalt (27)				
Co-55	5×10^{-1}	5×10^{-1}	1×10^1	1×10^6
Co-56	3×10^{-1}	3×10^{-1}	1×10^1	1×10^5
Co-57	1×10^1	1×10^1	1×10^2	1×10^6
Co-58	1×10^0	1×10^0	1×10^1	1×10^6
Co-58m	4×10^1	4×10^1	1×10^4	1×10^7
Co-60	4×10^{-1}	4×10^{-1}	1×10^1	1×10^5
Chromium (24)				
Cr-51	3×10^1	3×10^1	1×10^3	1×10^7
Caesium (55)				
Cs-129	4×10^0	4×10^0	1×10^2	1×10^5
Cs-131	3×10^1	3×10^1	1×10^3	1×10^6
Cs-132	1×10^0	1×10^0	1×10^1	1×10^5
Cs-134	7×10^{-1}	7×10^{-1}	1×10^1	1×10^4
Cs-134m	4×10^1	6×10^{-1}	1×10^3	1×10^5
Cs-135	4×10^1	1×10^0	1×10^4	1×10^7
Cs-136	5×10^{-1}	5×10^{-1}	1×10^1	1×10^5
Cs-137 (a)	2×10^0	6×10^{-1}	1×10^1 (b)	1×10^4 (b)

Radionuclide (atomic number)	A₁ (TBq)	A₂ (TBq)	Activity concentration for exempt material (Bq/g)	Activity limit for an exempt consignment (Bq)
Copper (29)				
Cu-64	6×10^0	1×10^0	1×10^2	1×10^6
Cu-67	1×10^1	7×10^{-1}	1×10^2	1×10^6
Dysprosium (66)				
Dy-159	2×10^1	2×10^1	1×10^3	1×10^7
Dy-165	9×10^{-1}	6×10^{-1}	1×10^3	1×10^6
Dy-166 (a)	9×10^{-1}	3×10^{-1}	1×10^3	1×10^6
Erbium (68)				
Er-169	4×10^1	1×10^0	1×10^4	1×10^7
Er-171	8×10^{-1}	5×10^{-1}	1×10^2	1×10^6
Europium (63)				
Eu-147	2×10^0	2×10^0	1×10^2	1×10^6
Eu-148	5×10^{-1}	5×10^{-1}	1×10^1	1×10^6
Eu-149	2×10^1	2×10^1	1×10^2	1×10^7
Eu-150(short lived)	2×10^0	7×10^{-1}	1×10^3	1×10^6
Eu-150(long lived)	7×10^{-1}	7×10^{-1}	1×10^1	1×10^6
Eu-152	1×10^0	1×10^0	1×10^1	1×10^6
Eu-152m	8×10^{-1}	8×10^{-1}	1×10^2	1×10^6
Eu-154	9×10^{-1}	6×10^{-1}	1×10^1	1×10^6
Eu-155	2×10^1	3×10^0	1×10^2	1×10^7
Eu-156	7×10^{-1}	7×10^{-1}	1×10^1	1×10^6
Fluorine (9)				
F-18	1×10^0	6×10^{-1}	1×10^1	1×10^6
Iron (26)				
Fe-52 (a)	3×10^{-1}	3×10^{-1}	1×10^1	1×10^6
Fe-55	4×10^1	4×10^1	1×10^4	1×10^6
Fe-59	9×10^{-1}	9×10^{-1}	1×10^1	1×10^6
Fe-60 (a)	4×10^1	2×10^{-1}	1×10^2	1×10^5
Gallium (31)				
Ga-67	7×10^0	3×10^0	1×10^2	1×10^6
Ga-68	5×10^{-1}	5×10^{-1}	1×10^1	1×10^5

Radionuclide (atomic number)	A₁ (TBq)	A₂ (TBq)	Activity concentration for exempt material (Bq/g)	Activity limit for an exempt consignment (Bq)
Ga-72	4×10^{-1}	4×10^{-1}	1×10^1	1×10^5
Gadolinium (64)				
Gd-146 (a)	5×10^{-1}	5×10^{-1}	1×10^1	1×10^6
Gd-148	2×10^1	2×10^{-3}	1×10^1	1×10^4
Gd-153	1×10^1	9×10^0	1×10^2	1×10^7
Gd-159	3×10^0	6×10^{-1}	1×10^3	1×10^6
Germanium (32)				
Ge-68 (a)	5×10^{-1}	5×10^{-1}	1×10^1	1×10^5
Ge-71	4×10^1	4×10^1	1×10^4	1×10^8
Ge-77	3×10^{-1}	3×10^{-1}	1×10^1	1×10^5
Hafnium (72)				
Hf-172 (a)	6×10^{-1}	6×10^{-1}	1×10^1	1×10^6
Hf-175	3×10^0	3×10^0	1×10^2	1×10^6
Hf-181	2×10^0	5×10^{-1}	1×10^1	1×10^6
Hf-182	Unlimited	Unlimited	1×10^2	1×10^6
Mercury (80)				
Hg-194 (a)	1×10^0	1×10^0	1×10^1	1×10^6
Hg-195m (a)	3×10^0	7×10^{-1}	1×10^2	1×10^6
Hg-197	2×10^1	1×10^1	1×10^2	1×10^7
Hg-197m	1×10^1	4×10^{-1}	1×10^2	1×10^6
Hg-203	5×10^0	1×10^0	1×10^2	1×10^5
Holmium (67)				
Ho-166	4×10^{-1}	4×10^{-1}	1×10^3	1×10^5
Ho-166m	6×10^{-1}	5×10^{-1}	1×10^1	1×10^6
Iodine (53)				
I-123	6×10^0	3×10^0	1×10^2	1×10^7
I-124	1×10^0	1×10^0	1×10^1	1×10^6
I-125	2×10^1	3×10^0	1×10^3	1×10^6
I-126	2×10^0	1×10^0	1×10^2	1×10^6
I-129	Unlimited	Unlimited	1×10^2	1×10^5
I-131	3×10^0	7×10^{-1}	1×10^2	1×10^6

Radionuclide (atomic number)	A₁ (TBq)	A₂ (TBq)	Activity concentration for exempt material (Bq/g)	Activity limit for an exempt consignment (Bq)
I-132	4×10^{-1}	4×10^{-1}	1×10^1	1×10^5
I-133	7×10^{-1}	6×10^{-1}	1×10^1	1×10^6
I-134	3×10^{-1}	3×10^{-1}	1×10^1	1×10^5
I-135 (a)	6×10^{-1}	6×10^{-1}	1×10^1	1×10^6
Indium (49)				
In-111	3×10^0	3×10^0	1×10^2	1×10^6
In-113m	4×10^0	2×10^0	1×10^2	1×10^6
In-114m (a)	1×10^1	5×10^{-1}	1×10^2	1×10^6
In-115m	7×10^0	1×10^0	1×10^2	1×10^6
Iridium (77)				
Ir-189 (a)	1×10^1	1×10^1	1×10^2	1×10^7
Ir-190	7×10^{-1}	7×10^{-1}	1×10^1	1×10^6
Ir-192	1×10^0 (c)	6×10^{-1}	1×10^1	1×10^4
Ir-194	3×10^{-1}	3×10^{-1}	1×10^2	1×10^5
Potassium (19)				
K-40	9×10^{-1}	9×10^{-1}	1×10^2	1×10^6
K-42	2×10^{-1}	2×10^{-1}	1×10^2	1×10^6
K-43	7×10^{-1}	6×10^{-1}	1×10^1	1×10^6
Krypton (36)				
Kr-79	4×10^0	2×10^0	1×10^3	1×10^5
Kr-81	4×10^1	4×10^1	1×10^4	1×10^7
Kr-85	1×10^1	1×10^1	1×10^5	1×10^4
Kr-85m	8×10^0	3×10^0	1×10^3	1×10^{10}
Kr-87	2×10^{-1}	2×10^{-1}	1×10^2	1×10^9
Lanthanum (57)				
La-137	3×10^1	6×10^0	1×10^3	1×10^7
La-140	4×10^{-1}	4×10^{-1}	1×10^1	1×10^5
Lutetium (71)				
Lu-172	6×10^{-1}	6×10^{-1}	1×10^1	1×10^6
Lu-173	8×10^0	8×10^0	1×10^2	1×10^7
Lu-174	9×10^0	9×10^0	1×10^2	1×10^7

Radionuclide (atomic number)	A₁ (TBq)	A₂ (TBq)	Activity concentration for exempt material (Bq/g)	Activity limit for an exempt consignment (Bq)
Lu-174m	2×10^1	1×10^1	1×10^2	1×10^7
Lu-177	3×10^1	7×10^{-1}	1×10^3	1×10^7
Magnesium (12)				
Mg-28 (a)	3×10^{-1}	3×10^{-1}	1×10^1	1×10^5
Manganese (25)				
Mn-52	3×10^{-1}	3×10^{-1}	1×10^1	1×10^5
Mn-53	Unlimited	Unlimited	1×10^4	1×10^9
Mn-54	1×10^0	1×10^0	1×10^1	1×10^6
Mn-56	3×10^{-1}	3×10^{-1}	1×10^1	1×10^5
Molybdenum (42)				
Mo-93	4×10^1	2×10^1	1×10^3	1×10^8
Mo-99 (a)	1×10^0	6×10^{-1}	1×10^2	1×10^6
Nitrogen (7)				
N-13	9×10^{-1}	6×10^{-1}	1×10^2	1×10^9
Sodium (11)				
Na-22	5×10^{-1}	5×10^{-1}	1×10^1	1×10^6
Na-24	2×10^{-1}	2×10^{-1}	1×10^1	1×10^5
Niobium (41)				
Nb-93m	4×10^1	3×10^1	1×10^4	1×10^7
Nb-94	7×10^{-1}	7×10^{-1}	1×10^1	1×10^6
Nb-95	1×10^0	1×10^0	1×10^1	1×10^6
Nb-97	9×10^{-1}	6×10^{-1}	1×10^1	1×10^6
Neodymium (60)				
Nd-147	6×10^0	6×10^{-1}	1×10^2	1×10^6
Nd-149	6×10^{-1}	5×10^{-1}	1×10^2	1×10^6
Nickel (28)				
Ni-59	Unlimited	Unlimited	1×10^4	1×10^8
Ni-63	4×10^1	3×10^1	1×10^5	1×10^8
Ni-65	4×10^{-1}	4×10^{-1}	1×10^1	1×10^6
Neptunium (93)				
Np-235	4×10^1	4×10^1	1×10^3	1×10^7

Radionuclide (atomic number)	A₁ (TBq)	A₂ (TBq)	Activity concentration for exempt material (Bq/g)	Activity limit for an exempt consignment (Bq)
Np-236(short-lived)	2×10^1	2×10^0	1×10^3	1×10^7
Np-236(long-lived)	9×10^0	2×10^{-2}	1×10^2	1×10^5
Np-237	2×10^1	2×10^{-3}	1×10^0 (b)	1×10^3 (b)
Np-239	7×10^0	4×10^{-1}	1×10^2	1×10^7
Osmium (76)				
Os-185	1×10^0	1×10^0	1×10^1	1×10^6
Os-191	1×10^1	2×10^0	1×10^2	1×10^7
Os-191m	4×10^1	3×10^1	1×10^3	1×10^7
Os-193	2×10^0	6×10^{-1}	1×10^2	1×10^6
Os-194 (a)	3×10^{-1}	3×10^{-1}	1×10^2	1×10^5
Phosphorus (15)				
P-32	5×10^{-1}	5×10^{-1}	1×10^3	1×10^5
P-33	4×10^1	1×10^0	1×10^5	1×10^8
Protactinium (91)				
Pa-230 (a)	2×10^0	7×10^{-2}	1×10^1	1×10^6
Pa-231	4×10^0	4×10^{-4}	1×10^0	1×10^3
Pa-233	5×10^0	7×10^{-1}	1×10^2	1×10^7
Lead (82)				
Pb-201	1×10^0	1×10^0	1×10^1	1×10^6
Pb-202	4×10^1	2×10^1	1×10^3	1×10^6
Pb-203	4×10^0	3×10^0	1×10^2	1×10^6
Pb-205	Unlimited	Unlimited	1×10^4	1×10^7
Pb-210 (a)	1×10^0	5×10^{-2}	1×10^1 (b)	1×10^4 (b)
Pb-212 (a)	7×10^{-1}	2×10^{-1}	1×10^1 (b)	1×10^5 (b)
Palladium (46)				
Pd-103 (a)	4×10^1	4×10^1	1×10^3	1×10^8
Pd-107	Unlimited	Unlimited	1×10^5	1×10^8
Pd-109	2×10^0	5×10^{-1}	1×10^3	1×10^6
Promethium (61)				
Pm-143	3×10^0	3×10^0	1×10^2	1×10^6
Pm-144	7×10^{-1}	7×10^{-1}	1×10^1	1×10^6

Radionuclide (atomic number)	A₁ (TBq)	A₂ (TBq)	Activity concentration for exempt material (Bq/g)	Activity limit for an exempt consignment (Bq)
Pm-145	3×10^1	1×10^1	1×10^3	1×10^7
Pm-147	4×10^1	2×10^0	1×10^4	1×10^7
Pm-148m (a)	8×10^{-1}	7×10^{-1}	1×10^1	1×10^6
Pm-149	2×10^0	6×10^{-1}	1×10^3	1×10^6
Pm-151	2×10^0	6×10^{-1}	1×10^2	1×10^6
Polonium (84)				
Po-210	4×10^1	2×10^{-2}	1×10^1	1×10^4
Praseodymium (59)				
Pr-142	4×10^{-1}	4×10^{-1}	1×10^2	1×10^5
Pr-143	3×10^0	6×10^{-1}	1×10^4	1×10^6
Platinum (78)				
Pt-188 (a)	1×10^0	8×10^{-1}	1×10^1	1×10^6
Pt-191	4×10^0	3×10^0	1×10^2	1×10^6
Pt-193	4×10^1	4×10^1	1×10^4	1×10^7
Pt-193m	4×10^1	5×10^{-1}	1×10^3	1×10^7
Pt-195m	1×10^1	5×10^{-1}	1×10^2	1×10^6
Pt-197	2×10^1	6×10^{-1}	1×10^3	1×10^6
Pt-197m	1×10^1	6×10^{-1}	1×10^2	1×10^6
Plutonium (94)				
Pu-236	3×10^1	3×10^{-3}	1×10^1	1×10^4
Pu-237	2×10^1	2×10^1	1×10^3	1×10^7
Pu-238	1×10^1	1×10^{-3}	1×10^0	1×10^4
Pu-239	1×10^1	1×10^{-3}	1×10^0	1×10^4
Pu-240	1×10^1	1×10^{-3}	1×10^0	1×10^3
Pu-241 (a)	4×10^1	6×10^{-2}	1×10^2	1×10^5
Pu-242	1×10^1	1×10^{-3}	1×10^0	1×10^4
Pu-244 (a)	4×10^{-1}	1×10^{-3}	1×10^0	1×10^4
Radium (88)				
Ra-223 (a)	4×10^{-1}	7×10^{-3}	1×10^2 (b)	1×10^5 (b)
Ra-224 (a)	4×10^{-1}	2×10^{-2}	1×10^1 (b)	1×10^5 (b)
Ra-225 (a)	2×10^{-1}	4×10^{-3}	1×10^2	1×10^5

Radionuclide (atomic number)	A₁ (TBq)	A₂ (TBq)	Activity concentration for exempt material (Bq/g)	Activity limit for an exempt consignment (Bq)
Ra-226 (a)	2×10^{-1}	3×10^{-3}	1×10^1 (b)	1×10^4 (b)
Ra-228 (a)	6×10^{-1}	2×10^{-2}	1×10^1 (b)	1×10^5 (b)
Rubidium (37)				
Rb-81	2×10^0	8×10^{-1}	1×10^1	1×10^6
Rb-83 (a)	2×10^0	2×10^0	1×10^2	1×10^6
Rb-84	1×10^0	1×10^0	1×10^1	1×10^6
Rb-86	5×10^{-1}	5×10^{-1}	1×10^2	1×10^5
Rb-87	Unlimited	Unlimited	1×10^4	1×10^7
Rb(nat)	Unlimited	Unlimited	1×10^4	1×10^7
Rhenium (75)				
Re-184	1×10^0	1×10^0	1×10^1	1×10^6
Re-184m	3×10^0	1×10^0	1×10^2	1×10^6
Re-186	2×10^0	6×10^{-1}	1×10^3	1×10^6
Re-187	Unlimited	Unlimited	1×10^6	1×10^9
Re-188	4×10^{-1}	4×10^{-1}	1×10^2	1×10^5
Re-189 (a)	3×10^0	6×10^{-1}	1×10^2	1×10^6
Re(nat)	Unlimited	Unlimited	1×10^6	1×10^9
Rhodium (45)				
Rh-99	2×10^0	2×10^0	1×10^1	1×10^6
Rh-101	4×10^0	3×10^0	1×10^2	1×10^7
Rh-102	5×10^{-1}	5×10^{-1}	1×10^1	1×10^6
Rh-102m	2×10^0	2×10^0	1×10^2	1×10^6
Rh-103m	4×10^1	4×10^1	1×10^4	1×10^8
Rh-105	1×10^1	8×10^{-1}	1×10^2	1×10^7
Radon (86)				
Rn-222 (a)	3×10^{-1}	4×10^{-3}	1×10^1 (b)	1×10^8 (b)
Ruthenium (44)				
Ru-97	5×10^0	5×10^0	1×10^2	1×10^7
Ru-103 (a)	2×10^0	2×10^0	1×10^2	1×10^6
Ru-105	1×10^0	6×10^{-1}	1×10^1	1×10^6
Ru-106 (a)	2×10^{-1}	2×10^{-1}	1×10^2 (b)	1×10^5 (b)

Radionuclide (atomic number)	A₁ (TBq)	A₂ (TBq)	Activity concentration for exempt material (Bq/g)	Activity limit for an exempt consignment (Bq)
Sulphur (16)				
S-35	4×10^1	3×10^0	1×10^5	1×10^8
Antimony (51)				
Sb-122	4×10^{-1}	4×10^{-1}	1×10^2	1×10^4
Sb-124	6×10^{-1}	6×10^{-1}	1×10^1	1×10^6
Sb-125	2×10^0	1×10^0	1×10^2	1×10^6
Sb-126	4×10^{-1}	4×10^{-1}	1×10^1	1×10^5
Scandium (21)				
Sc-44	5×10^{-1}	5×10^{-1}	1×10^1	1×10^5
Sc-46	5×10^{-1}	5×10^{-1}	1×10^1	1×10^6
Sc-47	1×10^1	7×10^{-1}	1×10^2	1×10^6
Sc-48	3×10^{-1}	3×10^{-1}	1×10^1	1×10^5
Selenium (34)				
Se-75	3×10^0	3×10^0	1×10^2	1×10^6
Se-79	4×10^1	2×10^0	1×10^4	1×10^7
Silicon (14)				
Si-31	6×10^{-1}	6×10^{-1}	1×10^3	1×10^6
Si-32	4×10^1	5×10^{-1}	1×10^3	1×10^6
Samarium (62)				
Sm-145	1×10^1	1×10^1	1×10^2	1×10^7
Sm-147	Unlimited	Unlimited	1×10^1	1×10^4
Sm-151	4×10^1	1×10^1	1×10^4	1×10^8
Sm-153	9×10^0	6×10^{-1}	1×10^2	1×10^6
Tin (50)				
Sn-113 (a)	4×10^0	2×10^0	1×10^3	1×10^7
Sn-117m	7×10^0	4×10^{-1}	1×10^2	1×10^6
Sn-119m	4×10^1	3×10^1	1×10^3	1×10^7
Sn-121m (a)	4×10^1	9×10^{-1}	1×10^3	1×10^7
Sn-123	8×10^{-1}	6×10^{-1}	1×10^3	1×10^6
Sn-125	4×10^{-1}	4×10^{-1}	1×10^2	1×10^5
Sn-126 (a)	6×10^{-1}	4×10^{-1}	1×10^1	1×10^5

Radionuclide (atomic number)	A₁ (TBq)	A₂ (TBq)	Activity concentration for exempt material (Bq/g)	Activity limit for an exempt consignment (Bq)
Strontium (38)				
Sr-82 (a)	2×10^{-1}	2×10^{-1}	1×10^1	1×10^5
Sr-85	2×10^0	2×10^0	1×10^2	1×10^6
Sr-85m	5×10^0	5×10^0	1×10^2	1×10^7
Sr-87m	3×10^0	3×10^0	1×10^2	1×10^6
Sr-89	6×10^{-1}	6×10^{-1}	1×10^3	1×10^6
Sr-90 (a)	3×10^{-1}	3×10^{-1}	1×10^2 (b)	1×10^4 (b)
Sr-91 (a)	3×10^{-1}	3×10^{-1}	1×10^1	1×10^5
Sr-92 (a)	1×10^0	3×10^{-1}	1×10^1	1×10^6
Tritium (1)				
T(H-3)	4×10^1	4×10^1	1×10^6	1×10^9
Tantalum (73)				
Ta-178(long-lived)	1×10^0	8×10^{-1}	1×10^1	1×10^6
Ta-179	3×10^1	3×10^1	1×10^3	1×10^7
Ta-182	9×10^{-1}	5×10^{-1}	1×10^1	1×10^4
Terbium (65)				
Tb-157	4×10^1	4×10^1	1×10^4	1×10^7
Tb-158	1×10^0	1×10^0	1×10^1	1×10^6
Tb-160	1×10^0	6×10^{-1}	1×10^1	1×10^6
Technetium (43)				
Tc-95m (a)	2×10^0	2×10^0	1×10^1	1×10^6
Tc-96	4×10^{-1}	4×10^{-1}	1×10^1	1×10^6
Tc-96m (a)	4×10^{-1}	4×10^{-1}	1×10^3	1×10^7
Tc-97	Unlimited	Unlimited	1×10^3	1×10^8
Tc-97m	4×10^1	1×10^0	1×10^3	1×10^7
Tc-98	8×10^{-1}	7×10^{-1}	1×10^1	1×10^6
Tc-99	4×10^1	9×10^{-1}	1×10^4	1×10^7
Tc-99m	1×10^1	4×10^0	1×10^2	1×10^7
Tellurium (52)				
Te-121	2×10^0	2×10^0	1×10^1	1×10^6
Te-121m	5×10^0	3×10^0	1×10^2	1×10^6

Radionuclide (atomic number)	A₁ (TBq)	A₂ (TBq)	Activity concentration for exempt material (Bq/g)	Activity limit for an exempt consignment (Bq)
Te-123m	8×10^0	1×10^0	1×10^2	1×10^7
Te-125m	2×10^1	9×10^{-1}	1×10^3	1×10^7
Te-127	2×10^1	7×10^{-1}	1×10^3	1×10^6
Te-127m (a)	2×10^1	5×10^{-1}	1×10^3	1×10^7
Te-129	7×10^{-1}	6×10^{-1}	1×10^2	1×10^6
Te-129m (a)	8×10^{-1}	4×10^{-1}	1×10^3	1×10^6
Te-131m (a)	7×10^{-1}	5×10^{-1}	1×10^1	1×10^6
Te-132 (a)	5×10^{-1}	4×10^{-1}	1×10^2	1×10^7
Thorium (90)				
Th-227	1×10^1	5×10^{-3}	1×10^1	1×10^4
Th-228 (a)	5×10^{-1}	1×10^{-3}	1×10^0 (b)	1×10^4 (b)
Th-229	5×10^0	5×10^{-4}	1×10^0 (b)	1×10^3 (b)
Th-230	1×10^1	1×10^{-3}	1×10^0	1×10^4
Th-231	4×10^1	2×10^{-2}	1×10^3	1×10^7
Th-232	Unlimited	Unlimited	1×10^1	1×10^4
Th-234 (a)	3×10^{-1}	3×10^{-1}	1×10^3 (b)	1×10^5 (b)
Th(nat)	Unlimited	Unlimited	1×10^0 (b)	1×10^3 (b)
Titanium (22)				
Ti-44 (a)	5×10^{-1}	4×10^{-1}	1×10^1	1×10^5
Thallium (81)				
Tl-200	9×10^{-1}	9×10^{-1}	1×10^1	1×10^6
Tl-201	1×10^1	4×10^0	1×10^2	1×10^6
Tl-202	2×10^0	2×10^0	1×10^2	1×10^6
Tl-204	1×10^1	7×10^{-1}	1×10^4	1×10^4
Thulium (69)				
Tm-167	7×10^0	8×10^{-1}	1×10^2	1×10^6
Tm-170	3×10^0	6×10^{-1}	1×10^3	1×10^6
Tm-171	4×10^1	4×10^1	1×10^4	1×10^8
Uranium (92)				
U-230 (fast lung absorption) (a)(d)	4×10^1	1×10^{-1}	1×10^1 (b)	1×10^5 (b)
U-230 (medium lung absorption) (a)(e)	4×10^1	4×10^{-3}	1×10^1	1×10^4

Radionuclide (atomic number)	A₁ (TBq)	A₂ (TBq)	Activity concentration for exempt material (Bq/g)	Activity limit for an exempt consignment (Bq)
U-230 (slow lung absorption) (a)(f)	3×10^1	3×10^{-3}	1×10^1	1×10^4
U-232 (fast lung absorption) (d)	4×10^1	1×10^{-2}	1×10^0 (b)	1×10^3 (b)
U-232 (medium lung absorption) (e)	4×10^1	7×10^{-3}	1×10^1	1×10^4
U-232 (slow lung absorption) (f)	1×10^1	1×10^{-3}	1×10^1	1×10^4
U-233 (fast lung absorption) (d)	4×10^1	9×10^{-2}	1×10^1	1×10^4
U-233 (medium lung absorption) (e)	4×10^1	2×10^{-2}	1×10^2	1×10^5
U-233 (slow lung absorption) (f)	4×10^1	6×10^{-3}	1×10^1	1×10^5
U-234 (fast lung absorption) (d)	4×10^1	9×10^{-2}	1×10^1	1×10^4
U-234 (medium lung absorption) (e)	4×10^1	2×10^{-2}	1×10^2	1×10^5
U-234 (slow lung absorption) (f)	4×10^1	6×10^{-3}	1×10^1	1×10^5
U-235 (all lung absorption types) (a)(d)(e)(f)	Unlimited	Unlimited	1×10^1 (b)	1×10^4 (b)
U-236 (fast lung absorption) (d)	Unlimited	Unlimited	1×10^1	1×10^4
U-236 (medium lung absorption) (e)	4×10^1	2×10^{-2}	1×10^2	1×10^5
U-236 (slow lung absorption) (f)	4×10^1	6×10^{-3}	1×10^1	1×10^4
U-238 (all lung absorption types) (d)(e)(f)	Unlimited	Unlimited	1×10^1 (b)	1×10^4 (b)
U (nat)	Unlimited	Unlimited	1×10^0 (b)	1×10^3 (b)
U (enriched to 20% or less) (g)	Unlimited	Unlimited	1×10^0	1×10^3
U (dep)	Unlimited	Unlimited	1×10^0	1×10^3
Vanadium (23)				
V-48	4×10^{-1}	4×10^{-1}	1×10^1	1×10^5
V-49	4×10^1	4×10^1	1×10^4	1×10^7
Tungsten (74)				
W-178 (a)	9×10^0	5×10^0	1×10^1	1×10^6
W-181	3×10^1	3×10^1	1×10^3	1×10^7
W-185	4×10^1	8×10^{-1}	1×10^4	1×10^7
W-187	2×10^0	6×10^{-1}	1×10^2	1×10^6
W-188 (a)	4×10^{-1}	3×10^{-1}	1×10^2	1×10^5

Radionuclide (atomic number)	A₁ (TBq)	A₂ (TBq)	Activity concentration for exempt material (Bq/g)	Activity limit for an exempt consignment (Bq)
Xenon (54)				
Xe-122 (a)	4×10^{-1}	4×10^{-1}	1×10^2	1×10^9
Xe-123	2×10^0	7×10^{-1}	1×10^2	1×10^9
Xe-127	4×10^0	2×10^0	1×10^3	1×10^5
Xe-131m	4×10^1	4×10^1	1×10^4	1×10^4
Xe-133	2×10^1	1×10^1	1×10^3	1×10^4
Xe-135	3×10^0	2×10^0	1×10^3	1×10^{10}
Yttrium (39)				
Y-87 (a)	1×10^0	1×10^0	1×10^1	1×10^6
Y-88	4×10^{-1}	4×10^{-1}	1×10^1	1×10^6
Y-90	3×10^{-1}	3×10^{-1}	1×10^3	1×10^5
Y-91	6×10^{-1}	6×10^{-1}	1×10^3	1×10^6
Y-91m	2×10^0	2×10^0	1×10^2	1×10^6
Y-92	2×10^{-1}	2×10^{-1}	1×10^2	1×10^5
Y-93	3×10^{-1}	3×10^{-1}	1×10^2	1×10^5
Ytterbium (70)				
Yb-169	4×10^0	1×10^0	1×10^2	1×10^7
Yb-175	3×10^1	9×10^{-1}	1×10^3	1×10^7
Zinc (30)				
Zn-65	2×10^0	2×10^0	1×10^1	1×10^6
Zn-69	3×10^0	6×10^{-1}	1×10^4	1×10^6
Zn-69m (a)	3×10^0	6×10^{-1}	1×10^2	1×10^6
Zirconium (40)				
Zr-88	3×10^0	3×10^0	1×10^2	1×10^6
Zr-93	Unlimited	Unlimited	1×10^3 (b)	1×10^7 (b)
Zr-95 (a)	2×10^0	8×10^{-1}	1×10^1	1×10^6
Zr-97 (a)	4×10^{-1}	4×10^{-1}	1×10^1 (b)	1×10^5 (b)

- (a) A_1 and/or A_2 values for these parent radionuclides include contributions from daughter radionuclides with half-lives less than 10 days, as listed in the following:

Mg-28	Al-28
Ar-42	K-42
Ca-47	Sc-47
Ti-44	Sc-44
Fe-52	Mn-52m
Fe-60	Co-60m
Zn-69m	Zn-69
Ge-68	Ga-68
Rb-83	Kr-83m
Sr-82	Rb-82
Sr-90	Y-90
Sr-91	Y-91m
Sr-92	Y-92
Y-87	Sr-87m
Zr-95	Nb-95m
Zr-97	Nb-97m, Nb-97
Mo-99	Tc-99m
Tc-95m	Tc-95
Tc-96m	Tc-96
Ru-103	Rh-103m
Ru-106	Rh-106
Pd-103	Rh-103m
Ag-108m	Ag-108
Ag-110m	Ag-110
Cd-115	In-115m
In-114m	In-114
Sn-113	In-113m
Sn-121m	Sn-121
Sn-126	Sb-126m
Te-118	Sb-118
Te-127m	Te-127
Te-129m	Te-129
Te-131m	Te-131
Te-132	I-132
I-135	Xe-135m
Xe-122	I-122
Cs-137	Ba-137m
Ba-131	Cs-131
Ba-140	La-140
Ce-144	Pr-144m, Pr-144
Pm-148m	Pm-148
Gd-146	Eu-146
Dy-166	Ho-166
Hf-172	Lu-172
W-178	Ta-178
W-188	Re-188
Re-189	Os-189m
Os-194	Ir-194
Ir-189	Os-189m
Pt-188	Ir-188
Hg-194	Au-194
Hg-195m	Hg-195
Pb-210	Bi-210
Pb-212	Bi-212, Tl-208, Po-212
Bi-210m	Tl-206

Bi-212	Tl-208, Po-212
At-211	Po-211
Rn-222	Po-218, Pb-214, At-218, Bi-214, Po-214
Ra-223	Rn-219, Po-215, Pb-211, Bi-211, Po-211, Tl-207
Ra-224	Rn-220, Po-216, Pb-212, Bi-212, Tl-208, Po-212
Ra-225	Ac-225, Fr-221, At-217, Bi-213, Tl-209, Po-213, Pb-209
Ra-226	Rn-222, Po-218, Pb-214, At-218, Bi-214, Po-214
Ra-228	Ac-228
Ac-225	Fr-221, At-217, Bi-213, Tl-209, Po-213, Pb-209
Ac-227	Fr-223
Th-228	Ra-224, Rn-220, Po-216, Pb-212, Bi-212, Tl-208, Po-212
Th-234	Pa-234m, Pa-234
Pa-230	Ac-226, Th-226, Fr-222, Ra-222, Rn-218, Po-214
U-230	Th-226, Ra-222, Rn-218, Po-214
U-235	Th-231
Pu-241	U-237
Pu-244	U-240, Np-240m
Am-242m	Am-242, Np-238
Am-243	Np-239
Cm-247	Pu-243
Bk-249	Am-245
Cf-253	Cm-249

- (b) Parent nuclides and their progeny included in secular equilibrium are listed in the following:

Sr-90	Y-90
Zr-93	Nb-93m
Zr-97	Nb-97
Ru-106	Rh-106
Ag-108m	Ag-108
Cs-137	Ba-137m
Ce-144	Pr-144
Ba-140	La-140
Bi-212	Tl-208 (0.36), Po-212 (0.64)
Pb-210	Bi-210, Po-210
Pb-212	Bi-212, Tl-208 (0.36), Po-212 (0.64)
Rn-222	Po-218, Pb-214, Bi-214, Po-214
Ra-223	Rn-219, Po-215, Pb-211, Bi-211, Tl-207
Ra-224	Rn-220, Po-216, Pb-212, Bi-212, Tl-208 (0.36), Po-212 (0.64)
Ra-226	Rn-222, Po-218, Pb-214, Bi-214, Po-214, Pb-210, Bi-210, Po-210
Ra-228	Ac-228
Th-228	Ra-224, Rn-220, Po-216, Pb-212, Bi-212, Tl-208 (0.36), Po-212 (0.64)
Th-229	Ra-225, Ac-225, Fr-221, At-217, Bi-213, Po-213, Pb-209
Th-nat	Ra-228, Ac-228, Th-228, Ra-224, Rn-220, Po-216, Pb-212, Bi-212, Tl-208 (0.36), Po-212 (0.64)
Th-234	Pa-234m
U-230	Th-226, Ra-222, Rn-218, Po-214
U-232	Th-228, Ra-224, Rn-220, Po-216, Pb-212, Bi-212, Tl-208 (0.36), Po-212 (0.64)
U-235	Th-231
U-238	Th-234, Pa-234m
U-nat	Th-234, Pa-234m, U-234, Th-230, Ra-226, Rn-222, Po-218, Pb-214, Bi-214, Po-214, Pb-210, Bi-210, Po-210
Np-237	Pa-233
Am-242m	Am-242
Am-243	Np-239

- (c) The quantity may be determined from a measurement of the rate of decay or a measurement of the radiation level at a prescribed distance from the source.
- (d) These values apply only to compounds of uranium that take the chemical form of UF_6 , UO_2F_2 and $UO_2(NO_3)_2$ in both normal and accident conditions of carriage.
- (e) These values apply only to compounds of uranium that take the chemical form of UO_3 , UF_4 , UCl_4 and hexavalent compounds in both normal and accident conditions of carriage.
- (f) These values apply to all compounds of uranium other than those specified in (d) and (e) above.
- (g) These values apply to unirradiated uranium only.

2.2.7.2.2.2 For individual radionuclides which are not listed in Table 2.2.7.2.2.1 the determination of the basic radionuclide values referred to in 2.2.7.2.2.1 shall require multilateral approval. It is permissible to use an A_2 value calculated using a dose coefficient for the appropriate lung absorption type as recommended by the International Commission on Radiological Protection, if the chemical forms of each radionuclide under both normal and accident conditions of carriage are taken into consideration. Alternatively, the radionuclide values in Table 2.2.7.2.2.2 may be used without obtaining competent authority approval.

Table 2.2.7.2.2.2: Basic radionuclide values for unknown radionuclides or mixtures

Radioactive contents	A_1	A_2	Activity concentration for exempt material	Activity limit for exempt consignments
	(TBq)	(TBq)	(Bq/g)	(Bq)
Only beta or gamma emitting nuclides are known to be present	0.1	0.02	1×10^1	1×10^4
Alpha emitting nuclides but no neutron emitters are known to be present	0.2	9×10^{-5}	1×10^{-1}	1×10^3
Neutron emitting nuclides are known to be present or no relevant data are available	0.001	9×10^{-5}	1×10^{-1}	1×10^3

2.2.7.2.2.3 In the calculations of A_1 and A_2 for a radionuclide not in Table 2.2.7.2.2.1, a single radioactive decay chain in which the radionuclides are present in their naturally occurring proportions, and in which no daughter nuclide has a half-life either longer than 10 days or longer than that of the parent nuclide, shall be considered as a single radionuclide; and the activity to be taken into account and the A_1 or A_2 value to be applied shall be those corresponding to the parent nuclide of that chain. In the case of radioactive decay chains in which any daughter nuclide has a half-life either longer than 10 days or greater than that of the parent nuclide, the parent and such daughter nuclides shall be considered as mixtures of different nuclides.

2.2.7.2.2.4 For mixtures of radionuclides, the determination of the basic radionuclide values referred to in 2.2.7.2.2.1 may be determined as follows:

$$X_m = \frac{1}{\sum_i \frac{f(i)}{X(i)}}$$

where,

f(i) is the fraction of activity or activity concentration of radionuclide i in the mixture;

X(i) is the appropriate value of A₁ or A₂, or the activity concentration for exempt material or the activity limit for an exempt consignment as appropriate for the radionuclide i; and

X_m is the derived value of A₁ or A₂, or the activity concentration for exempt material or the activity limit for an exempt consignment in the case of a mixture.

2.2.7.2.2.5 When the identity of each radionuclide is known but the individual activities of some of the radionuclides are not known, the radionuclides may be grouped and the lowest radionuclide value, as appropriate, for the radionuclides in each group may be used in applying the formulas in 2.2.7.2.2.4 and 2.2.7.2.4.4. Groups may be based on the total alpha activity and the total beta/gamma activity when these are known, using the lowest radionuclide values for the alpha emitters or beta/gamma emitters, respectively.

2.2.7.2.2.6 For individual radionuclides or for mixtures of radionuclides for which relevant data are not available, the values shown in Table 2.2.7.2.2.2 shall be used.

2.2.7.2.3 *Determination of other material characteristics*

2.2.7.2.3.1 Low specific activity (LSA) material

2.2.7.2.3.1.1 *(Reserved)*

2.2.7.2.3.1.2 LSA material shall be in one of three groups:

(a) LSA-I

- (i) uranium and thorium ores and concentrates of such ores, and other ores containing naturally occurring radionuclides which are intended to be processed for the use of these radionuclides;
- (ii) natural uranium, depleted uranium, natural thorium or their compounds or mixtures, that are unirradiated and in solid or liquid form;
- (iii) radioactive material for which the A₂ value is unlimited, excluding fissile material not excepted under 2.2.7.2.3.5; or
- (iv) other radioactive material in which the activity is distributed throughout and the estimated average specific activity does not exceed 30 times the values for activity concentration specified in 2.2.7.2.2.1 to 2.2.7.2.2.6, excluding fissile material not excepted under 2.2.7.2.3.5;

- (b) LSA-II
 - (i) water with tritium concentration up to 0.8 TBq/l; or
 - (ii) other material in which the activity is distributed throughout and the estimated average specific activity does not exceed 10^{-4} A₂/g for solids and gases, and 10^{-5} A₂/g for liquids;
- (c) LSA-III - Solids (e.g. consolidated wastes, activated materials), excluding powders, meeting the requirements of 2.2.7.2.3.1.3, in which:
 - (i) the radioactive material is distributed throughout a solid or a collection of solid objects, or is essentially uniformly distributed in a solid compact binding agent (such as concrete, bitumen, ceramic, etc.);
 - (ii) the radioactive material is relatively insoluble, or it is intrinsically contained in a relatively insoluble matrix, so that, even under loss of packaging, the loss of radioactive material per package by leaching when placed in water for seven days would not exceed 0.1 A₂; and
 - (iii) the estimated average specific activity of the solid, excluding any shielding material, does not exceed 2×10^{-3} A₂/g.

2.2.7.2.3.1.3 LSA-III material shall be a solid of such a nature that if the entire contents of a package were subjected to the test specified in 2.2.7.2.3.1.4 the activity in the water would not exceed 0.1 A₂.

2.2.7.2.3.1.4 LSA-III material shall be tested as follows:

A solid material sample representing the entire contents of the package shall be immersed for 7 days in water at ambient temperature. The volume of water to be used in the test shall be sufficient to ensure that at the end of the 7 day test period the free volume of the unabsorbed and unreacted water remaining shall be at least 10% of the volume of the solid test sample itself. The water shall have an initial pH of 6-8 and a maximum conductivity of 1 mS/m at 20 °C. The total activity of the free volume of water shall be measured following the 7 day immersion of the test sample.

2.2.7.2.3.1.5 Demonstration of compliance with the performance standards in 2.2.7.2.3.1.4 shall be in accordance with 6.4.12.1 and 6.4.12.2.

2.2.7.2.3.2 Surface contaminated object (SCO)

SCO is classified in one of two groups:

- (a) SCO-I: A solid object on which:
 - (i) the non-fixed contamination on the accessible surface averaged over 300 cm² (or the area of the surface if less than 300 cm²) does not exceed 4 Bq/cm² for beta and gamma emitters and low toxicity alpha emitters, or 0.4 Bq/cm² for all other alpha emitters; and
 - (ii) the fixed contamination on the accessible surface averaged over 300 cm² (or the area of the surface if less than 300 cm²) does not exceed 4×10^4 Bq/cm² for beta and gamma emitters and low toxicity alpha emitters, or 4×10^3 Bq/cm² for all other alpha emitters; and

- (iii) the non-fixed contamination plus the fixed contamination on the inaccessible surface averaged over 300 cm^2 (or the area of the surface if less than 300 cm^2) does not exceed $4 \times 10^4 \text{ Bq/cm}^2$ for beta and gamma emitters and low toxicity alpha emitters, or $4 \times 10^3 \text{ Bq/cm}^2$ for all other alpha emitters;
- (b) SCO-II: A solid object on which either the fixed or non-fixed contamination on the surface exceeds the applicable limits specified for SCO-I in (a) above and on which:
- (i) the non-fixed contamination on the accessible surface averaged over 300 cm^2 (or the area of the surface if less than 300 cm^2) does not exceed 400 Bq/cm^2 for beta and gamma emitters and low toxicity alpha emitters, or 40 Bq/cm^2 for all other alpha emitters; and
 - (ii) the fixed contamination on the accessible surface, averaged over 300 cm^2 (or the area of the surface if less than 300 cm^2) does not exceed $8 \times 10^5 \text{ Bq/cm}^2$ for beta and gamma emitters and low toxicity alpha emitters, or $8 \times 10^4 \text{ Bq/cm}^2$ for all other alpha emitters; and
 - (iii) the non-fixed contamination plus the fixed contamination on the inaccessible surface averaged over 300 cm^2 (or the area of the surface if less than 300 cm^2) does not exceed $8 \times 10^5 \text{ Bq/cm}^2$ for beta and gamma emitters and low toxicity alpha emitters, or $8 \times 10^4 \text{ Bq/cm}^2$ for all other alpha emitters.

2.2.7.2.3.3 Special form radioactive material

2.2.7.2.3.3.1 Special form radioactive material shall have at least one dimension not less than 5 mm. When a sealed capsule constitutes part of the special form radioactive material, the capsule shall be so manufactured that it can be opened only by destroying it. The design for special form radioactive material requires unilateral approval.

2.2.7.2.3.3.2 Special form radioactive material shall be of such a nature or shall be so designed that if it is subjected to the tests specified in 2.2.7.2.3.3.4 to 2.2.7.2.3.3.8, it shall meet the following requirements:

- (a) It would not break or shatter under the impact, percussion and bending tests 2.2.7.2.3.3.5 (a), (b), (c) and 2.2.7.2.3.3.6 (a) as applicable;
- (b) It would not melt or disperse in the applicable heat test 2.2.7.2.3.3.5 (d) or 2.2.7.2.3.3.6 (b) as applicable; and
- (c) The activity in the water from the leaching tests specified in 2.2.7.2.3.3.7 and 2.2.7.2.3.3.8 would not exceed 2 kBq; or alternatively for sealed sources, the leakage rate for the volumetric leakage assessment test specified in ISO 9978:1992 "Radiation Protection - Sealed Radioactive Sources - Leakage Test Methods", would not exceed the applicable acceptance threshold acceptable to the competent authority.

2.2.7.2.3.3.3 Demonstration of compliance with the performance standards in 2.2.7.2.3.3.2 shall be in accordance with 6.4.12.1 and 6.4.12.2.

2.2.7.2.3.3.4 Specimens that comprise or simulate special form radioactive material shall be subjected to the impact test, the percussion test, the bending test, and the heat test specified in 2.2.7.2.3.3.5 or alternative tests as authorized in 2.2.7.2.3.3.6. A different specimen may be used for each of the tests. Following each test, a leaching assessment or volumetric leakage test shall be performed on the specimen by a method no less sensitive than the methods given in 2.2.7.2.3.3.7 for indispersible solid material or 2.2.7.2.3.3.8 for encapsulated material.

2.2.7.2.3.3.5 The relevant test methods are:

- (a) Impact test: The specimen shall drop onto the target from a height of 9 m. The target shall be as defined in 6.4.14;
- (b) Percussion test: The specimen shall be placed on a sheet of lead which is supported by a smooth solid surface and struck by the flat face of a mild steel bar so as to cause an impact equivalent to that resulting from a free drop of 1.4 kg through 1 m. The lower part of the bar shall be 25 mm in diameter with the edges rounded off to a radius of (3.0 ± 0.3) mm. The lead, of hardness number 3.5 to 4.5 on the Vickers scale and not more than 25 mm thick, shall cover an area greater than that covered by the specimen. A fresh surface of lead shall be used for each impact. The bar shall strike the specimen so as to cause maximum damage;
- (c) Bending test: The test shall apply only to long, slender sources with both a minimum length of 10 cm and a length to minimum width ratio of not less than 10. The specimen shall be rigidly clamped in a horizontal position so that one half of its length protrudes from the face of the clamp. The orientation of the specimen shall be such that the specimen will suffer maximum damage when its free end is struck by the flat face of a steel bar. The bar shall strike the specimen so as to cause an impact equivalent to that resulting from a free vertical drop of 1.4 kg through 1 m. The lower part of the bar shall be 25 mm in diameter with the edges rounded off to a radius of (3.0 ± 0.3) mm;
- (d) Heat test: The specimen shall be heated in air to a temperature of 800 °C and held at that temperature for a period of 10 minutes and shall then be allowed to cool.

2.2.7.2.3.3.6 Specimens that comprise or simulate radioactive material enclosed in a sealed capsule may be excepted from:

- (a) The tests prescribed in 2.2.7.2.3.3.5 (a) and (b) provided the mass of the special form radioactive material:
 - (i) is less than 200 g and they are alternatively subjected to the Class 4 impact test prescribed in ISO 2919:1999 "Radiation protection - Sealed radioactive sources - General requirements and classification"; or
 - (ii) is less than 500 g and they are alternatively subjected to the Class 5 impact test prescribed in ISO 2919:1999 "Radiation protection - Sealed radioactive sources - General requirements and classification"; and
- (b) The test prescribed in 2.2.7.2.3.3.5 (d) provided they are alternatively subjected to the Class 6 temperature test specified in ISO 2919:1999 "Radiation protection - Sealed radioactive sources - General requirements and classification".

2.2.7.2.3.3.7 For specimens which comprise or simulate indispersible solid material, a leaching assessment shall be performed as follows:

- (a) The specimen shall be immersed for 7 days in water at ambient temperature. The volume of water to be used in the test shall be sufficient to ensure that at the end of the 7 day test period the free volume of the unabsorbed and unreacted water remaining shall be at least 10% of the volume of the solid test sample itself. The water shall have an initial pH of 6-8 and a maximum conductivity of 1 mS/m at 20 °C;
- (b) The water with specimen shall then be heated to a temperature of (50 ± 5) °C and maintained at this temperature for 4 hours;

- (c) The activity of the water shall then be determined;
- (d) The specimen shall then be kept for at least 7 days in still air at not less than 30 °C and relative humidity not less than 90%;
- (e) The specimen shall then be immersed in water of the same specification as in (a) above and the water with the specimen heated to (50 ± 5) °C and maintained at this temperature for 4 hours;
- (f) The activity of the water shall then be determined.

2.2.7.2.3.3.8 For specimens which comprise or simulate radioactive material enclosed in a sealed capsule, either a leaching assessment or a volumetric leakage assessment shall be performed as follows:

- (a) The leaching assessment shall consist of the following steps:
 - (i) the specimen shall be immersed in water at ambient temperature. The water shall have an initial pH of 6-8 with a maximum conductivity of 1 mS/m at 20 °C;
 - (ii) the water and specimen shall be heated to a temperature of (50 ± 5) °C and maintained at this temperature for 4 hours;
 - (iii) the activity of the water shall then be determined;
 - (iv) the specimen shall then be kept for at least 7 days in still air at not less than 30 °C and relative humidity of not less than 90%;
 - (v) the process in (i), (ii) and (iii) shall be repeated;
- (b) The alternative volumetric leakage assessment shall comprise any of the tests prescribed in ISO 9978:1992 "Radiation Protection - Sealed radioactive sources - Leakage test methods", which are acceptable to the competent authority.

2.2.7.2.3.4 Low dispersible radioactive material

2.2.7.2.3.4.1 The design for low dispersible radioactive material shall require multilateral approval. Low dispersible radioactive material shall be such that the total amount of this radioactive material in a package, taking into account the provisions of 6.4.8.14, shall meet the following requirements:

- (a) The radiation level at 3 m from the unshielded radioactive material does not exceed 10 mSv/h;
- (b) If subjected to the tests specified in 6.4.20.3 and 6.4.20.4, the airborne release in gaseous and particulate forms of up to 100 µm aerodynamic equivalent diameter would not exceed 100 A₂. A separate specimen may be used for each test; and
- (c) If subjected to the test specified in 2.2.7.2.3.1.4 the activity in the water would not exceed 100 A₂. In the application of this test, the damaging effects of the tests specified in (b) above shall be taken into account.

2.2.7.2.3.4.2 Low dispersible radioactive material shall be tested as follows:

A specimen that comprises or simulates low dispersible radioactive material shall be subjected to the enhanced thermal test specified in 6.4.20.3 and the impact test specified in 6.4.20.4. A different specimen may be used for each of the tests. Following each test, the specimen shall be subjected to the leach test specified in 2.2.7.2.3.1.4. After each test it shall be determined if the applicable requirements of 2.2.7.2.3.4.1 have been met.

2.2.7.2.3.4.3 Demonstration of compliance with the performance standards in 2.2.7.2.3.4.1 and 2.2.7.2.3.4.2 shall be in accordance with 6.4.12.1 and 6.4.12.2.

2.2.7.2.3.5 Fissile material

Packages containing fissile material shall be classified under the relevant entry of Table 2.2.7.2.1.1, the description of which includes the words "FISSILE" or "fissile-excepted". Classification as "fissile-excepted" is allowed only if one of the conditions (a) to (d) of this paragraph is met. Only one type of exception is allowed per consignment (see also 6.4.7.2).

- (a) A mass limit per consignment, provided that the smallest external dimension of each package is not less than 10 cm, such that:

$$\frac{\text{mass of uranium-235 (g)}}{X} + \frac{\text{mass of other fissile material (g)}}{Y} < 1$$

where X and Y are the mass limits defined in Table 2.2.7.2.3.5, provided that either:

- (i) each individual package contains not more than 15 g of fissile nuclides; for unpackaged material, this quantity limitation shall apply to the consignment being carried in or on the vehicle; or
- (ii) the fissile material is a homogeneous hydrogenous solution or mixture where the ratio of fissile nuclides to hydrogen is less than 5% by mass; or
- (iii) there are not more than 5 g of fissile nuclides in any 10 litre volume of material.

Beryllium shall not be present in quantities exceeding 1% of the applicable consignment mass limits provided in Table 2.2.7.2.3.5 except where the concentration of beryllium in the material does not exceed 1 gram beryllium in any 1 000 grams.

Deuterium shall also not be present in quantities exceeding 1% of the applicable consignment mass limits provided in Table 2.2.7.2.3.5 except where deuterium occurs up to natural concentration in hydrogen.

- (b) Uranium enriched in uranium-235 to a maximum of 1% by mass, and with a total plutonium and uranium-233 content not exceeding 1% of the mass of uranium-235, provided that the fissile nuclides are distributed essentially homogeneously throughout the material. In addition, if uranium-235 is present in metallic, oxide or carbide forms, it shall not form a lattice arrangement;
- (c) Liquid solutions of uranyl nitrate enriched in uranium-235 to a maximum of 2% by mass, with a total plutonium and uranium-233 content not exceeding 0.002% of the mass of uranium, and with a minimum nitrogen to uranium atomic ratio (N/U) of 2;
- (d) Plutonium containing not more than 20% of fissile nuclides by mass up to a maximum of 1 kg of plutonium per consignment. Shipments under this exception shall be under exclusive use.

Table 2.2.7.2.3.5: Consignment mass limits for exceptions from the requirements for packages containing fissile material

Fissile material	Fissile material mass (g) mixed with substances having an average hydrogen density less than or equal to water	Fissile material mass (g) mixed with substances having an average hydrogen density greater than water
Uranium-235 (X)	400	290
Other fissile material (Y)	250	180

2.2.7.2.4 *Classification of packages or unpacked material*

The quantity of radioactive material in a package shall not exceed the relevant limits for the package type as specified below.

2.2.7.2.4.1 Classification as excepted package

2.2.7.2.4.1.1 Packages may be classified as excepted packages if:

- (a) They are empty packagings having contained radioactive material;
- (b) They contain instruments or articles in limited quantities as specified in Table 2.2.7.2.4.1.2;
- (c) They contain articles manufactured of natural uranium, depleted uranium or natural thorium; or
- (d) They contain radioactive material in limited quantities as specified in Table 2.2.7.2.4.1.2.

2.2.7.2.4.1.2 A package containing radioactive material may be classified as an excepted package provided that the radiation level at any point on its external surface does not exceed 5 µSv/h.

Table 2.2.7.2.4.1.2: Activity limits for excepted packages

Physical state of contents	Instruments or articles		Materials Package limits^a
	Item limits^a	Package limits^a	
(1)	(2)	(3)	(4)
Solids			
special form	$10^{-2} A_1$	A_1	$10^{-3} A_1$
other form	$10^{-2} A_2$	A_2	$10^{-3} A_2$
Liquids	$10^{-3} A_2$	$10^{-1} A_2$	$10^{-4} A_2$
Gases			
tritium	$2 \times 10^{-2} A_2$	$2 \times 10^{-1} A_2$	$2 \times 10^{-2} A_2$
special form	$10^{-3} A_1$	$10^{-2} A_1$	$10^{-3} A_1$
other forms	$10^{-3} A_2$	$10^{-2} A_2$	$10^{-3} A_2$

^a For mixtures of radionuclides, see 2.2.7.2.2.4 to 2.2.7.2.2.6.

2.2.7.2.4.1.3 Radioactive material which is enclosed in or is included as a component part of an instrument or other manufactured article may be classified under UN No. 2911 RADIOACTIVE MATERIAL, EXCEPTED PACKAGE - INSTRUMENTS or ARTICLES only if:

- (a) The radiation level at 10 cm from any point on the external surface of any unpackaged instrument or article is not greater than 0.1 mSv/h; and
- (b) Each instrument or manufactured article bears the marking "RADIOACTIVE" except:
 - (i) radioluminescent time-pieces or devices;
 - (ii) consumer products that either have received regulatory approval according to 1.7.1.4 (d) or do not individually exceed the activity limit for an exempt consignment in Table 2.2.7.2.2.1 (column 5), provided such products are carried in a package that bears the marking "RADIOACTIVE" on an internal surface in such a manner that warning of the presence of radioactive material is visible on opening the package; and
- (c) The active material is completely enclosed by non-active components (a device performing the sole function of containing radioactive material shall not be considered to be an instrument or manufactured article); and
- (d) The limits specified in columns 2 and 3 of Table 2.2.7.2.4.1.2 are met for each individual item and each package, respectively.

2.2.7.2.4.1.4 Radioactive material in forms other than as specified in 2.2.7.2.4.1.3 and with an activity not exceeding the limits specified in column 4 of Table 2.2.7.2.4.1.2, may be classified under UN No. 2910 RADIOACTIVE MATERIAL, EXCEPTED PACKAGE - LIMITED QUANTITY OF MATERIAL provided that:

- (a) The package retains its radioactive contents under routine conditions of carriage; and
- (b) The package bears the marking "RADIOACTIVE" on an internal surface in such a manner that a warning of the presence of radioactive material is visible on opening the package.

2.2.7.2.4.1.5 An empty packaging which had previously contained radioactive material may be classified under UN No. 2908 RADIOACTIVE MATERIAL, EXCEPTED PACKAGE - EMPTY PACKAGING, only if:

- (a) It is in a well-maintained condition and securely closed;
- (b) The outer surface of any uranium or thorium in its structure is covered with an inactive sheath made of metal or some other substantial material;
- (c) The level of internal non-fixed contamination, when averaged over any 300 cm², does not exceed:
 - (i) 400 Bq/cm² for beta and gamma emitters and low toxicity alpha emitters; and
 - (ii) 40 Bq/cm² for all other alpha emitters; and
- (d) Any labels which may have been displayed on it in conformity with 5.2.2.1.11.1 are no longer visible.

2.2.7.2.4.1.6 Articles manufactured of natural uranium, depleted uranium or natural thorium and articles in which the sole radioactive material is unirradiated natural uranium, unirradiated depleted uranium or unirradiated natural thorium may be classified under UN No. 2909 RADIOACTIVE MATERIAL, EXCEPTED PACKAGE - ARTICLES MANUFACTURED FROM NATURAL URANIUM or DEPLETED URANIUM or NATURAL THORIUM,

only if the outer surface of the uranium or thorium is enclosed in an inactive sheath made of metal or some other substantial material.

2.2.7.2.4.2 Classification as Low specific activity (LSA) material

Radioactive material may only be classified as LSA material if the definition of LSA in 2.2.7.1.3 and the conditions of 2.2.7.2.3.1, 4.1.9.2 and 7.5.11 CV33 (2) are met.

2.2.7.2.4.3 Classification as Surface contaminated object (SCO)

Radioactive material may be classified as SCO if the definition of SCO in 2.2.7.1.3 and the conditions of 2.2.7.2.3.2, 4.1.9.2 and 7.5.11 CV33 (2) are met.

2.2.7.2.4.4 Classification as Type A package

Packages containing radioactive material may be classified as Type A packages provided that the following conditions are met:

Type A packages shall not contain activities greater than the following:

- (a) For special form radioactive material - A_1 ; or
- (b) For all other radioactive material - A_2 .

For mixtures of radionuclides whose identities and respective activities are known, the following condition shall apply to the radioactive contents of a Type A package:

$$\sum_i \frac{B(i)}{A_1(i)} + \sum_j \frac{C(j)}{A_2(j)} \leq 1$$

where $B(i)$ is the activity of radionuclide i as special form radioactive material;

$A_1(i)$ is the A_1 value for radionuclide i ;

$C(j)$ is the activity of radionuclide j as other than special form radioactive material; and

$A_2(j)$ is the A_2 value for radionuclide j .

2.2.7.2.4.5 Classification of Uranium hexafluoride

Uranium hexafluoride shall only be assigned to UN Nos. 2977 RADIOACTIVE MATERIAL, URANIUM HEXAFLUORIDE, FISSILE, or 2978 RADIOACTIVE MATERIAL, URANIUM HEXAFLUORIDE, non fissile or fissile-excepted.

2.2.7.2.4.5.1 Packages containing uranium hexafluoride shall not contain:

- (a) A mass of uranium hexafluoride different from that authorized for the package design;
- (b) A mass of uranium hexafluoride greater than a value that would lead to an ullage smaller than 5% at the maximum temperature of the package as specified for the plant systems where the package shall be used; or
- (c) Uranium hexafluoride other than in solid form or at an internal pressure above atmospheric pressure when presented for carriage.

2.2.7.2.4.6 Classification as Type B(U), Type B(M) or Type C packages

2.2.7.2.4.6.1 Packages not otherwise classified in 2.2.7.2.4 (2.2.7.2.4.1 to 2.2.7.2.4.5) shall be classified in accordance with the competent authority approval certificate for the package issued by the country of origin of design.

2.2.7.2.4.6.2 A package may only be classified as a Type B(U) if it does not contain:

- (a) Activities greater than those authorized for the package design;
- (b) Radionuclides different from those authorized for the package design; or
- (c) Contents in a form, or a physical or chemical state different from those authorized for the package design;

as specified in the certificate of approval.

2.2.7.2.4.6.3 A package may only be classified as a Type B(M) if it does not contain:

- (a) Activities greater than those authorized for the package design;
- (b) Radionuclides different from those authorized for the package design; or
- (c) Contents in a form, or a physical or chemical state different from those authorized for the package design;

as specified in the certificate of approval.

2.2.7.2.4.6.4 A package may only be classified as a Type C if it does not contain:

- (a) Activities greater than those authorized for the package design;
- (b) Radionuclides different from those authorized for the package design; or
- (c) Contents in a form, or physical or chemical state different from those authorized for the package design;

as specified in the certificate of approval.

2.2.7.2.5 *Special arrangements*

Radioactive material shall be classified as transported under special arrangement when it is intended to be carried in accordance with 1.7.4.

2.2.8 Class 8 Corrosive substances**2.2.8.1 Criteria**

2.2.8.1.1 The heading of Class 8 covers substances and articles containing substances of this class which by chemical action attack epithelial tissue - of skin or mucous membranes - with which they are in contact, or which in the event of leakage are capable of damaging or destroying other goods, or means of transport. The heading of this class also covers other substances which form a corrosive liquid only in the presence of water, or which produce corrosive vapour or mist in the presence of natural moisture of the air.

2.2.8.1.2 Substances and articles of Class 8 are subdivided as follows:

C1-C10 Corrosive substances without subsidiary risk:

C1-C4 Acid substances:

- C1 Inorganic, liquid;
- C2 Inorganic, solid;
- C3 Organic, liquid;
- C4 Organic, solid;

C5-C8 Basic substances:

- C5 Inorganic, liquid;
- C6 Inorganic, solid;
- C7 Organic, liquid;
- C8 Organic, solid;

C9-C10 Other corrosive substances:

- C9 Liquid;
- C10 Solid;

C11 Articles;

CF Corrosive substances, flammable:

- CF1 Liquid;
- CF2 Solid;

CS Corrosive substances, self-heating:

- CS1 Liquid;
- CS2 Solid;

CW Corrosive substances which, in contact with water, emit flammable gases:

- CW1 Liquid;
- CW2 Solid;

CO Corrosive substances, oxidizing:

- CO1 Liquid;
- CO2 Solid;

CT Corrosive substances, toxic:

- CT1 Liquid;
- CT2 Solid;

CFT Corrosive substances, flammable, liquid, toxic;

COT Corrosive substances, oxidizing, toxic.

Classification and assignment of packing groups

2.2.8.1.3 Substances of Class 8 shall be classified in three packing groups according to the degree of danger they present for carriage, as follows:

Packing group I:	highly corrosive substances
Packing group II:	corrosive substances
Packing group III:	slightly corrosive substances.

2.2.8.1.4 Substances and articles classified in Class 8 are listed in Table A of Chapter 3.2. Allocation of substances to packing groups I, II and III has been made on the basis of experience taking into account such additional factors as inhalation risk (see 2.2.8.1.5) and reactivity with water (including the formation of dangerous decomposition products).

2.2.8.1.5 A substance or preparation meeting the criteria of Class 8 having an inhalation toxicity of dusts and mists (LC₅₀) in the range of packing group I, but toxicity through oral ingestion or dermal contact only in the range of packing group III or less, shall be allocated to Class 8.

2.2.8.1.6 Substances, including mixtures, not mentioned by name in Table A of Chapter 3.2 can be assigned to the relevant entry of sub-section 2.2.8.3, and to the relevant packing group on the basis of the length of time of contact necessary to produce full thickness destruction of human skin in accordance with the criteria of (a) to (c) below.

Liquids, and solids which may become liquid during carriage, which are judged not to cause full thickness destruction of human skin shall still be considered for their potential to cause corrosion to certain metal surfaces. In assigning the packing group, account shall be taken of human experience in instances of accidental exposure. In the absence of human experience, the grouping shall be based on data obtained from experiments in accordance with OECD Test Guideline 404⁷ or 435⁸. A substance which is determined not to be corrosive in accordance with OECD Test Guideline 430⁹ or 431¹⁰ may be considered not to be corrosive to skin for the purposes of ADR without further testing..

- (a) Packing group I is assigned to substances that cause full thickness destruction of intact skin tissue within an observation period up to 60 minutes starting after the exposure time of 3 minutes or less;
- (b) Packing group II is assigned to substances that cause full thickness destruction of intact skin tissue within an observation period up to 14 days starting after the exposure time of more than 3 minutes but not more than 60 minutes;
- (c) Packing group III is assigned to substances that:
 - cause full thickness destruction of intact skin tissue within an observation period up to 14 days starting after the exposure time of more than 60 minutes but not more than 4 hours; or
 - are judged not to cause full thickness destruction of intact skin tissue, but which exhibit a corrosion rate on either steel or aluminium surfaces exceeding 6.25 mm a year at a test temperature of 55 °C when tested on both materials. For the purposes of testing steel, type S235JR+CR (1.0037 resp. St 37-2),

⁷ OECD Guideline for the testing of chemicals No. 404 "Acute Dermal Irritation/Corrosion" 2002.

⁸ OECD Guideline for the testing of chemicals No. 435 "In Vitro Membrane Barrier Test Method for Skin Corrosion" 2006.

⁹ OECD Guideline for the testing of chemicals No. 430 "In Vitro Skin Corrosion: Transcutaneous Electrical Resistance Test (TER)" 2004.

¹⁰ OECD Guideline for the testing of chemicals No. 431 "In Vitro Skin Corrosion: Human Skin Model Test" 2004.

S275J2G3+CR (1.0144 resp. St 44-3), ISO 3574, Unified Numbering System (UNS) G10200 or SAE 1020, and for testing aluminium, non-clad, types 7075-T6 or AZ5GU-T6 shall be used. An acceptable test is prescribed in the Manual of Tests and Criteria, Part III, Section 37.

NOTE: Where an initial test on either steel or aluminium indicates the substance being tested is corrosive the follow up test on the other metal is not required.

2.2.8.1.7 If substances of Class 8, as a result of admixtures, come into categories of risk different from those to which the substances mentioned by name in Table A of Chapter 3.2 belong, these mixtures or solutions shall be assigned to the entries to which they belong, on the basis of their actual degree of danger.

NOTE: For the classification of solutions and mixtures (such as preparations and wastes), see also 2.1.3.

2.2.8.1.8 On the basis of the criteria set out in paragraph 2.2.8.1.6, it may also be determined whether the nature of a solution or mixture mentioned by name or containing a substance mentioned by name is such that the solution or mixture is not subject to the provisions for this class.

2.2.8.1.9 Substances, solutions and mixtures, which

- do not meet the criteria of Directives 67/548/EEC³ or 1999/45/EC⁴ as amended and therefore are not classified as corrosive according to these directives, as amended; and
- do not exhibit a corrosive effect on steel or aluminium;

may be considered as substances not belonging to Class 8.

NOTE: UN No. 1910 calcium oxide and UN No. 2812 sodium aluminate, listed in the UN Model Regulations, are not subject to the provisions of ADR.

2.2.8.2 Substances not accepted for carriage

2.2.8.2.1 The chemically unstable substances of Class 8 shall not be accepted for carriage unless the necessary steps have been taken to prevent their dangerous decomposition or polymerization during carriage. To this end it shall in particular be ensured that receptacles and tanks do not contain any substance liable to promote these reactions.

2.2.8.2.2 The following substances shall not be accepted for carriage:

- UN No. 1798 NITROHYDROCHLORIC ACID;
- chemically unstable mixtures of spent sulphuric acid;
- chemically unstable mixtures of nitrating acid or mixtures of residual sulphuric and nitric acids, not denitrated;
- perchloric acid aqueous solution with more than 72% pure acid, by mass, or mixtures of perchloric acid with any liquid other than water.

³ Council Directive 67/548/EEC of 27 June 1967 on the approximation of laws, regulations and administrative provisions relating to the classification, packaging and labelling of dangerous substances (Official Journal of the European Communities No. L 196 of 16.08.1967).

⁴ Directive 1999/45/EC of the European Parliament and of the Council of 31 May 1999 on the approximation of laws, regulations and administrative provisions of the Member States relating to the classification, packaging and labelling of dangerous preparations (Official Journal of the European Communities No. L 200 of 30 July 1999).

2.2.8.3 *List of collective entries***Corrosive substances without subsidiary risk**

Acid	inorganic	liquid C1	2584 ALKYL SULPHONIC ACIDS, LIQUID with more than 5% free sulphuric acid or 2584 ARYL SULPHONIC ACIDS, LIQUID with more than 5% free sulphuric acid 2693 BISULPHITES, AQUEOUS SOLUTION, N.O.S. 2837 BISULPHATES, AQUEOUS SOLUTION 3264 CORROSIVE LIQUID, ACIDIC, INORGANIC, N.O.S.
		solid C2	1740 HYDROGEN DIFLUORIDES, SOLID, N.O.S. 2583 ALKYL SULPHONIC ACIDS, SOLID with more than 5% free sulphuric acid or 2583 ARYL SULPHONIC ACIDS, SOLID with more than 5% free sulphuric acid 3260 CORROSIVE SOLID, ACIDIC, INORGANIC, N.O.S.
C1-C4	organic	liquid C3	2586 ALKYL SULPHONIC ACIDS, LIQUID with not more than 5% free sulphuric acid or 2586 ARYL SULPHONIC ACIDS, LIQUID with not more than 5% free sulphuric acid 2987 CHLOROSILANES, CORROSIVE, N.O.S. 3145 ALKYL PHENOLS, LIQUID, N.O.S. (including C ₂ -C ₁₂ homologues) 3265 CORROSIVE LIQUID, ACIDIC, ORGANIC, N.O.S.
		solid C4	2430 ALKYL PHENOLS, SOLID, N.O.S. (including C ₂ -C ₁₂ homologues) 2585 ALKYL SULPHONIC ACIDS, SOLID with not more than 5% free sulphuric acid or 2585 ARYL SULPHONIC ACIDS, SOLID with not more than 5% free sulphuric acid 3261 CORROSIVE SOLID, ACIDIC, ORGANIC, N.O.S.
Basic	inorganic	liquid C5	1719 CAUSTIC ALKALI LIQUID, N.O.S. 2797 BATTERY FLUID, ALKALI 3266 CORROSIVE LIQUID, BASIC, INORGANIC, N.O.S.
		solid C6	3262 CORROSIVE SOLID, BASIC, INORGANIC, N.O.S.
C5-C8	organic	liquid C7	2735 AMINES, LIQUID, CORROSIVE, N.O.S. or 2735 POLYAMINES, LIQUID, CORROSIVE, N.O.S. 3267 CORROSIVE LIQUID, BASIC, ORGANIC, N.O.S.
		solid C8	3259 AMINES, SOLID, CORROSIVE, N.O.S., or 3259 POLYAMINES, SOLID, CORROSIVE, N.O.S. 3263 CORROSIVE SOLID, BASIC, ORGANIC, N.O.S.
Other corrosive substances	C9-C10	liquid C9	1903 DISINFECTANT, LIQUID, CORROSIVE, N.O.S. 2801 DYE, LIQUID, CORROSIVE, N.O.S. or 2801 DYE INTERMEDIATE, LIQUID, CORROSIVE, N.O.S. 3066 PAINT (including paint, enamel, stain, shellac, varnish, polish, liquid filler and lacquer base) or 3066 PAINT RELATED MATERIAL (including paint thinning or reducing compound) 1760 CORROSIVE LIQUID, N.O.S.
		solid^a C10	3147 DYE, SOLID, CORROSIVE, N.O.S. or 3147 DYE INTERMEDIATE, SOLID, CORROSIVE, N.O.S. 3244 SOLIDS CONTAINING CORROSIVE LIQUID, N.O.S. 1759 CORROSIVE SOLID, N.O.S.
Articles		C11	2794 BATTERIES, WET, FILLED WITH ACID, electric storage 2795 BATTERIES, WET, FILLED WITH ALKALI, electric storage 2800 BATTERIES, WET, NON-SPILLABLE, electric storage 3028 BATTERIES, DRY, CONTAINING POTASSIUM HYDROXIDE SOLID, electric storage

(cont'd on next page)

^a Mixtures of solids which are not subject to the provisions of ADR and of corrosive liquids may be carried under UN No. 3244 without being subject to the classification criteria of Class 8, provided there is no free liquid visible at the time the substance is loaded or at the time the packaging, container or transport unit is closed. Each packaging shall correspond to a design type which has passed the leakproofness test for Packing group II level.

Corrosive substances with subsidiary risk(s)

<i>(cont'd)</i> Flammable^b	liquid	CF1	3470 PAINT, CORROSIVE, FLAMMABLE (including paint, enamel, stain, shellac, varnish, polish, liquid filler and lacquer base) or
			3470 PAINT RELATED MATERIAL, CORROSIVE, FLAMMABLE (including paint thinning or reducing compound)
			2734 AMINES, LIQUID, CORROSIVE, FLAMMABLE, N.O.S. or
			2734 POLYAMINES, LIQUID, CORROSIVE, FLAMMABLE, N.O.S.
			2986 CHLOROSILANES, CORROSIVE, FLAMMABLE, N.O.S. 2920 CORROSIVE LIQUID, FLAMMABLE, N.O.S.
CF	solid	CF2	2921 CORROSIVE SOLID, FLAMMABLE, N.O.S.
Self-heating			liquid
CS	solid	CS2	3095 CORROSIVE SOLID, SELF-HEATING, N.O.S.
Water-reactive			liquid^b
CW	solid	CW2	3096 CORROSIVE SOLID, WATER-REACTIVE, N.O.S.
Oxidizing			liquid
CO	solid	CO2	3084 CORROSIVE SOLID, OXIDIZING, N.O.S.
Toxic^d			liquid^c
	CT	solid^c	
Flammable, liquid, toxic^d	CFT		No collective entry with this classification code available; if need be, classification under a collective entry with a classification code to be determined according to table of precedence of hazard in 2.1.3.10.
Oxidizing, toxic^{d,e}	COT		No collective entry with this classification code available; if need be, classification under a collective entry with a classification code to be determined according to table of precedence of hazard in 2.1.3.10.

^b Chlorosilanes which, in contact with water or moist air, emit flammable gases, are substances of Class 4.3.

^c Chloroformates having predominantly toxic properties are substances of Class 6.1.

^d Corrosive substances which are highly toxic by inhalation, as defined in 2.2.61.1.4 to 2.2.61.1.9 are substances of Class 6.1.

^e UN No. 2505 AMMONIUM FLUORIDE, UN No. 1812 POTASSIUM FLUORIDE, SOLID, UN No. 1690 SODIUM FLUORIDE, SOLID, UN No. 2674 SODIUM FLUOROSILICATE, UN No. 2856 FLUOROSILICATES, N.O.S., UN No. 3415 SODIUM FLUORIDE SOLUTION and UN No. 3422 POTASSIUM FLUORIDE SOLUTION are substances of Class 6.1.

2.2.9 Class 9 Miscellaneous dangerous substances and articles

2.2.9.1 Criteria

2.2.9.1.1 The heading of Class 9 covers substances and articles which, during carriage, present a danger not covered by the heading of other classes.

2.2.9.1.2 The substances and articles of Class 9 are subdivided as follows:

M1 Substances which, on inhalation as fine dust, may endanger health;

M2 Substances and apparatus which, in the event of fire, may form dioxins;

M3 Substances evolving flammable vapour;

M4 Lithium batteries;

M5 Life-saving appliances;

M6-M8 Environmentally hazardous substances:

M6 Pollutant to the aquatic environment, liquid;

M7 Pollutant to the aquatic environment, solid;

M8 Genetically modified microorganisms and organisms;

M9-M10 Elevated temperature substances:

M9 Liquid;

M10 Solid;

M11 Other substances presenting a danger during carriage, but not meeting the definitions of another class.

Definitions and classification

2.2.9.1.3 Substances and articles classified in Class 9 are listed in Table A of Chapter 3.2. The assignment of substances and articles not mentioned by name in Table A of Chapter 3.2 to the relevant entry of that Table or of sub-section 2.2.9.3 shall be done in accordance with 2.2.9.1.4 to 2.2.9.1.14 below.

Substances which, on inhalation as fine dust, may endanger health

2.2.9.1.4 Substances which, on inhalation as fine dust, may endanger health include asbestos and mixtures containing asbestos.

Substances and apparatus which, in the event of fire, may form dioxins

2.2.9.1.5 Substances and apparatus which, in the event of fire, may form dioxins include polychlorinated biphenyls (PCBs) and terphenyls (PCTs) and polyhalogenated biphenyls and terphenyls and mixtures containing these substances, as well as apparatus such as transformers, condensers and apparatus containing those substances or mixtures.

NOTE: *Mixtures with a PCB or PCT content of not more than 50 mg/kg are not subject to the provisions of ADR.*

Substances evolving flammable vapour

- 2.2.9.1.6 Substances evolving flammable vapour include polymers containing flammable liquids with a flash-point not exceeding 55 °C.

Lithium batteries

- 2.2.9.1.7 The term "lithium battery" covers all cells and batteries containing lithium in any form. They may be assigned to Class 9 if they meet the requirements of special provision 230 of Chapter 3.3. They are not subject to the provisions of ADR if they meet the requirements of special provision 188 of Chapter 3.3. They shall be classified in accordance with the procedures of Section 38.3 of the Manual of Tests and Criteria.

Life-saving appliances

- 2.2.9.1.8 Life-saving appliances include life-saving appliances and motor vehicle components which meet the descriptions of special provisions 235 or 296 of Chapter 3.3.

Environmentally hazardous substances

- 2.2.9.1.9 *(Deleted)*

Pollutants to the aquatic environment

- 2.2.9.1.10 *Environmentally hazardous substances (aquatic environment)*

- 2.2.9.1.10.1 General definitions

- 2.2.9.1.10.1.1 Environmentally hazardous substances include, inter alia, liquid or solid substances pollutant to the aquatic environment and solutions and mixtures of such substances (such as preparations and wastes).

For the purposes of 2.2.9.1.10, "*substance*" means chemical elements and their compounds in the natural state or obtained by any production process, including any additive necessary to preserve the stability of the product and any impurities deriving from the process used, but excluding any solvent which may be separated without affecting the stability of the substance or changing its composition.

- 2.2.9.1.10.1.2 The aquatic environment may be considered in terms of the aquatic organisms that live in the water, and the aquatic ecosystem of which they are part¹¹. The basis, therefore, of the identification of hazard is the aquatic toxicity of the substance or mixture, although this may be modified by further information on the degradation and bioaccumulation behaviour.

- 2.2.9.1.10.1.3 While the following classification procedure is intended to apply to all substances and mixtures, it is recognised that in some cases, e.g. metals or poorly soluble inorganic compounds, special guidance will be necessary¹².

- 2.2.9.1.10.1.4 The following definitions apply for acronyms or terms used in this section:

- BCF: Bioconcentration Factor;
- BOD: Biochemical Oxygen Demand;
- COD: Chemical Oxygen Demand;

¹¹ This does not address aquatic pollutants for which there may be a need to consider effects beyond the aquatic environment such as the impacts on human health etc.

¹² This can be found in Annex 10 of the GHS.

- GLP: Good Laboratory Practices;
- EC_x : the concentration associated with x% response;
- EC_{50} : the effective concentration of substance that causes 50% of the maximum response;
- ErC_{50} : EC_{50} in terms of reduction of growth;
- Kow : octanol/water partition coefficient;
- LC_{50} (50% lethal concentration): the concentration of a substance in water which causes the death of 50% (one half) in a group of test animals;
- $L(E)C_{50}$: LC_{50} or EC_{50} ;
- NOEC (No Observed Effect Concentration): the test concentration immediately below the lowest tested concentration with statistically significant adverse effect. The NOEC has no statistically significant adverse effect compared to the control;
- OECD Test Guidelines: Test guidelines published by the Organization for Economic Cooperation and Development (OECD).

2.2.9.1.10.2 Definitions and data requirements

2.2.9.1.10.2.1 The basic elements for classification of environmentally hazardous substances (aquatic environment) are:

- (a) Acute aquatic toxicity;
- (b) Chronic aquatic toxicity;
- (c) Potential for or actual bioaccumulation; and
- (d) Degradation (biotic or abiotic) for organic chemicals.

2.2.9.1.10.2.2 While data from internationally harmonised test methods are preferred, in practice, data from national methods may also be used where they are considered as equivalent. In general, it has been agreed that freshwater and marine species toxicity data can be considered as equivalent data and are preferably to be derived using OECD Test Guidelines or equivalent according to the principles of Good Laboratory Practices (GLP). Where such data are not available, classification shall be based on the best available data.

2.2.9.1.10.2.3 *Acute aquatic toxicity* means the intrinsic property of a substance to be injurious to an organism in a short-term aquatic exposure to that substance.

Acute (short-term) hazard, for classification purposes, means the hazard of a chemical caused by its acute toxicity to an organism during short-term aquatic exposure to that chemical.

Acute aquatic toxicity shall normally be determined using a fish 96 hour LC_{50} (OECD Test Guideline 203 or equivalent), a crustacea species 48 hour EC_{50} (OECD Test Guideline 202 or equivalent) and/or an algal species 72 or 96 hour EC_{50} (OECD Test Guideline 201 or equivalent). These species are considered as surrogate for all aquatic organisms and data on other species such as Lemna may also be considered if the test methodology is suitable.

2.2.9.1.10.2.4 *Chronic aquatic toxicity* means the intrinsic property of a substance to cause adverse effects to aquatic organisms during aquatic exposures which are determined in relation to the life-cycle of the organism.

Long-term hazard, for classification purposes, means the hazard of a chemical caused by its chronic toxicity following long-term exposure in the aquatic environment.

Chronic toxicity data are less available than acute data and the range of testing procedures less standardised. Data generated according to the OECD Test Guidelines 210 (Fish Early Life Stage) or 211 (Daphnia Reproduction) and 201 (Algal Growth Inhibition) may be accepted. Other validated and internationally accepted tests may also be used. The NOECs or other equivalent EC_x shall be used.

2.2.9.1.10.2.5 *Bioaccumulation* means net result of uptake, transformation and elimination of a substance in an organism due to all routes of exposure (i.e. air, water, sediment/soil and food).

The potential for bioaccumulation shall normally be determined by using the octanol/water partition coefficient, usually reported as a log K_{ow} determined according to OECD Test Guideline 107 or 117. While this represents a potential to bioaccumulate, an experimentally determined Bioconcentration Factor (BCF) provides a better measure and shall be used in preference when available. A BCF shall be determined according to OECD Test Guideline 305.

2.2.9.1.10.2.6 *Degradation* means the decomposition of organic molecules to smaller molecules and eventually to carbon dioxide, water and salts.

Environmental degradation may be biotic or abiotic (e.g. hydrolysis) and the criteria used reflect this fact. Ready biodegradation is most easily defined using the biodegradability tests (A-F) of OECD Test Guideline 301. A pass level in these tests may be considered as indicative of rapid degradation in most environments. These are freshwater tests and thus the use of the results from OECD Test Guideline 306, which is more suitable for marine environments, has also been included. Where such data are not available, a BOD(5 days)/COD ratio ≥ 0.5 is considered as indicative of rapid degradation.

Abiotic degradation such as hydrolysis, primary degradation, both abiotic and biotic, degradation in non-aquatic media and proven rapid degradation in the environment may all be considered in defining rapid degradability¹³.

Substances are considered rapidly degradable in the environment if the following criteria are met:

- (a) In 28-day ready biodegradation studies, the following levels of degradation are achieved:
 - (i) Tests based on dissolved organic carbon: 70%;
 - (ii) Tests based on oxygen depletion or carbon dioxide generation: 60% of theoretical maxima;

These levels of biodegradation shall be achieved within 10 days of the start of degradation which point is taken as the time when 10% of the substance has been degraded", unless the substance is identified as a complex, multi-component substance with structurally similar constituents. In this case, and where there is sufficient justification, the 10-day window condition may be waived and the pass level applied at 28 days¹⁴; or

- (b) In those cases where only BOD and COD data are available, when the ratio of BOD5/COD is ≥ 0.5 ; or
- (c) If other convincing scientific evidence is available to demonstrate that the substance or mixture can be degraded (biotically and/or abiotically) in the aquatic environment to a level above 70% within a 28 day period.

¹³ Special guidance on data interpretation is provided in Chapter 4.1 and Annex 9 of the GHS.

¹⁴ See Chapter 4.1 and Annex 9, paragraph A9.4.2.2.3 of the GHS.

2.2.9.1.10.3 Substance classification categories and criteria

2.2.9.1.10.3.1 Substances shall be classified as "environmentally hazardous substances (aquatic environment)", if they satisfy the criteria for Acute 1, Chronic 1 or Chronic 2, according to Table 2.2.9.1.10.3.1. These criteria describe in detail the classification categories. They are diagrammatically summarized in Table 2.2.9.1.10.3.2.

Table 2.2.9.1.10.3.1: Categories for substances hazardous to the aquatic environment (see Note 1)

(a) Acute (short-term) aquatic hazard

Category Acute 1: (see Note 2)	
96 hr LC ₅₀ (for fish)	≤ 1 mg/l and/or
48 hr EC ₅₀ (for crustacea)	≤ 1 mg/l and/or
72 or 96hr ErC ₅₀ (for algae or other aquatic plants)	≤ 1 mg/l (see Note 3)

(b) Long-term aquatic hazard (see also Figure 2.2.9.1.10.3.1)

(i) Non-rapidly degradable substances (see Note 4) for which there are adequate chronic toxicity data available

Category Chronic 1: (see Note 2)	
Chronic NOEC or EC _x (for fish)	≤ 0.1 mg/l and/or
Chronic NOEC or EC _x (for crustacea)	≤ 0.1 mg/l and/or
Chronic NOEC or EC _x (for algae or other aquatic plants)	≤ 0.1 mg/l
Category Chronic 2:	
Chronic NOEC or EC _x (for fish)	≤ 1 mg/l and/or
Chronic NOEC or EC _x (for crustacea)	≤ 1 mg/l and/or
Chronic NOEC or EC _x (for algae or other aquatic plants)	≤ 1 mg/l

(ii) Rapidly degradable substances for which there are adequate chronic toxicity data available

Category Chronic 1: (see Note 2)	
Chronic NOEC or EC _x (for fish)	≤ 0.01 mg/l and/or
Chronic NOEC or EC _x (for crustacea)	≤ 0.01 mg/l and/or
Chronic NOEC or EC _x (for algae or other aquatic plants)	≤ 0.01 mg/l
Category Chronic 2:	
Chronic NOEC or EC _x (for fish)	≤ 0.1 mg/l and/or
Chronic NOEC or EC _x (for crustacea)	≤ 0.1 mg/l and/or
Chronic NOEC or EC _x (for algae or other aquatic plants)	≤ 0.1 mg/l

(iii) Substances for which adequate chronic toxicity data are not available

Category Chronic 1: (see Note 2)	
96 hr LC ₅₀ (for fish)	≤ 1 mg/l and/or
48 hr EC ₅₀ (for crustacea)	≤ 1 mg/l and/or
72 or 96hr ErC ₅₀ (for algae or other aquatic plants)	≤ 1 mg/l (see Note 3)
and the substance is not rapidly degradable and/or the experimentally determined BCF is ≥ 500 (or, if absent the log K _{ow} ≥ 4) (see Notes 4 and 5).	
Category Chronic 2:	
96 hr LC ₅₀ (for fish)	>1 but ≤ 10 mg/l and/or
48 hr EC ₅₀ (for crustacea)	>1 but ≤ 10 mg/l and/or
72 or 96hr ErC ₅₀ (for algae or other aquatic plants)	>1 but ≤ 10 mg/l (see Note 3)
and the substance is not rapidly degradable and/or the experimentally determined BCF is ≥ 500 (or, if absent the log K _{ow} ≥ 4) (see Notes 4 and 5).	

NOTE 1: The organisms fish, crustacea and algae are tested as surrogate species covering a range of trophic levels and taxa, and the test methods are highly standardized. Data on other organisms may also be considered, however, provided they represent equivalent species and test endpoints.

NOTE 2: When classifying substances as Acute 1 and/or Chronic 1 it is necessary at the same time to indicate an appropriate M factor (see 2.2.9.1.10.4.6.4) to apply the summation method.

NOTE 3: Where the algal toxicity ErC_{50} (= EC_{50} (growth rate)) falls more than 100 times below the next most sensitive species and results in a classification based solely on this effect, consideration shall be given to whether this toxicity is representative of the toxicity to aquatic plants. Where it can be shown that this is not the case, professional judgment shall be used in deciding if classification shall be applied. Classification shall be based on the ErC_{50} . In circumstances where the basis of the EC_{50} is not specified and no ErC_{50} is recorded, classification shall be based on the lowest EC_{50} available.

NOTE 4: Lack of rapid degradability is based on either a lack of ready biodegradability or other evidence of lack of rapid degradation. When no useful data on degradability are available, either experimentally determined or estimated data, the substance shall be regarded as not rapidly degradable.

NOTE 5: Potential to bioaccumulate, based on an experimentally derived $BCF \geq 500$ or, if absent, a $\log K_{ow} \geq 4$ provided $\log K_{ow}$ is an appropriate descriptor for the bioaccumulation potential of the substance. Measured $\log K_{ow}$ values take precedence over estimated values and measured BCF values take precedence over $\log K_{ow}$ values.

Figure 2.2.9.1.10.3.1: Categories for substances long-term hazardous to the aquatic environment

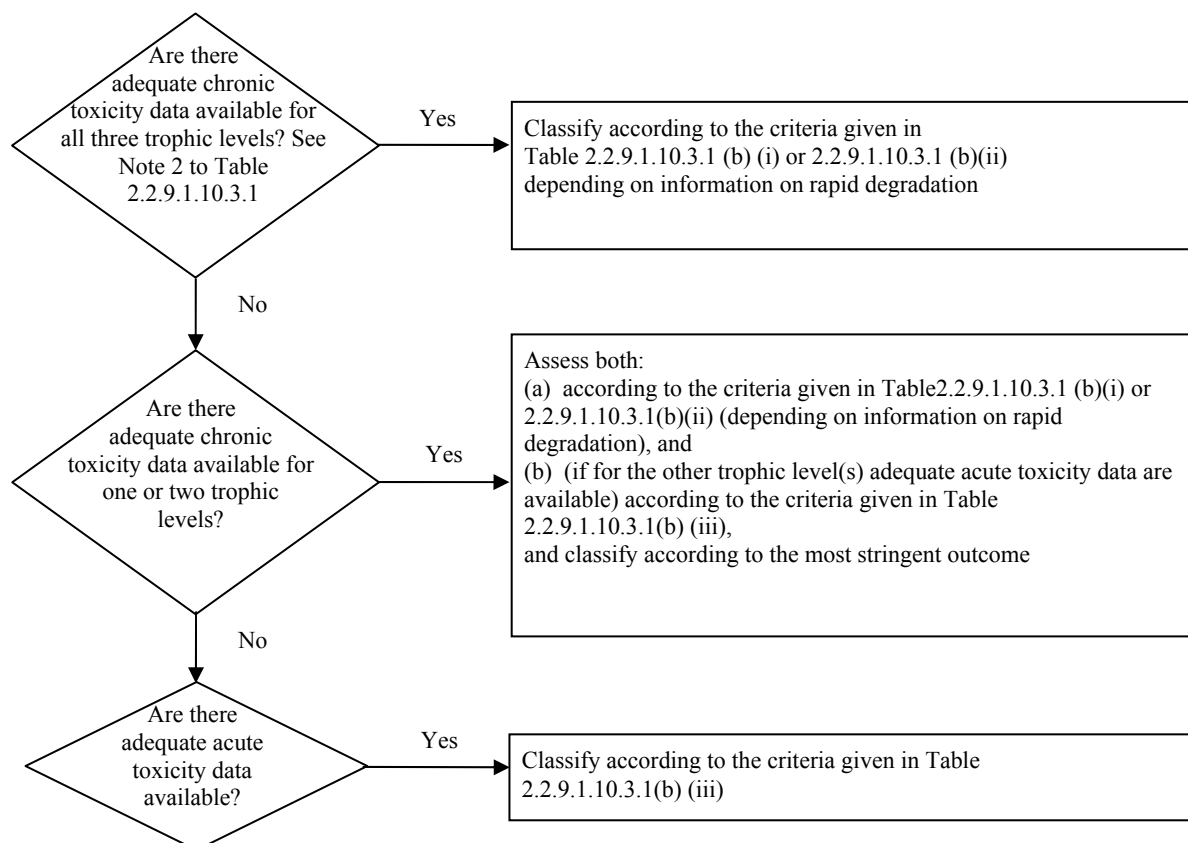

2.2.9.1.10.3.2 The classification scheme in Table 2.2.9.1.10.3.2 below summarizes the classification criteria for substances.

Table 2.2.9.1.10.3.2: Classification scheme for substances hazardous to the aquatic environment

Classification categories			
Acute hazard (see Note 1)	Long-term hazard (see Note 2)		
	Adequate chronic toxicity data available		Adequate chronic toxicity data not available (see Note 1)
	Non-rapidly degradable substances (see Note 3)	Rapidly degradable substances (see Note 3)	
Category: Acute 1	Category: Chronic 1	Category: Chronic 1	Category: Chronic 1
$L(E)C_{50} \leq 1.00$	$NOEC \text{ or } EC_x \leq 0.1$	$NOEC \text{ or } EC_x \leq 0.01$	$L(E)C_{50} \leq 1.00$ and lack of rapid degradability and/or $BCF \geq 500$ or, if absent $\log K_{ow} \geq 4$
	Category: Chronic 2	Category: Chronic 2	Category: Chronic 2
	$0.1 < NOEC \text{ or } EC_x \leq 1$	$0.01 < NOEC \text{ or } EC_x \leq 0.1$	$1.00 < L(E)C_{50} \leq 10.0$ and lack of rapid degradability and/or $BCF \geq 500$ or, if absent $\log K_{ow} \geq 4$

NOTE 1: Acute toxicity band based on $L(E)C_{50}$ values in mg/l for fish, crustacea and/or algae or other aquatic plants (or Quantitative Structure Activity Relationships (QSAR) estimation if no experimental data¹⁵).

NOTE 2: Substances are classified in the various chronic categories unless there are adequate chronic toxicity data available for all three trophic levels above the water solubility or above 1 mg/l. ("Adequate" means that the data sufficiently cover the endpoint of concern. Generally this would mean measured test data, but in order to avoid unnecessary testing it can on a case by case basis also be estimated data, e.g. (Q)SAR, or for obvious cases expert judgment).

NOTE 3: Chronic toxicity band based on $NOEC$ or equivalent EC_x values in mg/l for fish or crustacea or other recognized measures for chronic toxicity.

2.2.9.1.10.4 Mixtures classification categories and criteria

2.2.9.1.10.4.1 The classification system for mixtures covers the classification categories which are used for substances, meaning categories Acute 1 and Chronic 1 and 2. In order to make use of all available data for purposes of classifying the aquatic environmental hazards of the mixture, the following assumption is made and is applied where appropriate:

The "relevant ingredients" of a mixture are those which are present in a concentration equal to or greater than 0.1% (by mass) for ingredients classified as Acute and/or Chronic 1 and equal to or greater than 1% for other ingredients, unless there is a presumption (e.g. in the case of highly toxic ingredients) that an ingredient present at less than 0.1% can still be relevant for classifying the mixture for aquatic environmental hazards.

2.2.9.1.10.4.2 The approach for classification of aquatic environmental hazards is tiered, and is dependent upon the type of information available for the mixture itself and for its ingredients. Elements of the tiered approach include:

¹⁵ Special guidance is provided in Chapter 4.1, paragraph 4.1.2.13 and Annex 9, Section A9.6 of the GHS.

- (a) Classification based on tested mixtures;
- (b) Classification based on bridging principles;
- (c) The use of "summation of classified ingredients" and/or an "additivity formula".

Figure 2.2.9.1.10.4.2 below outlines the process to be followed.

Figure 2.2.9.1.10.4.2: Tiered approach to classification of mixtures for acute and long-term aquatic environmental hazards

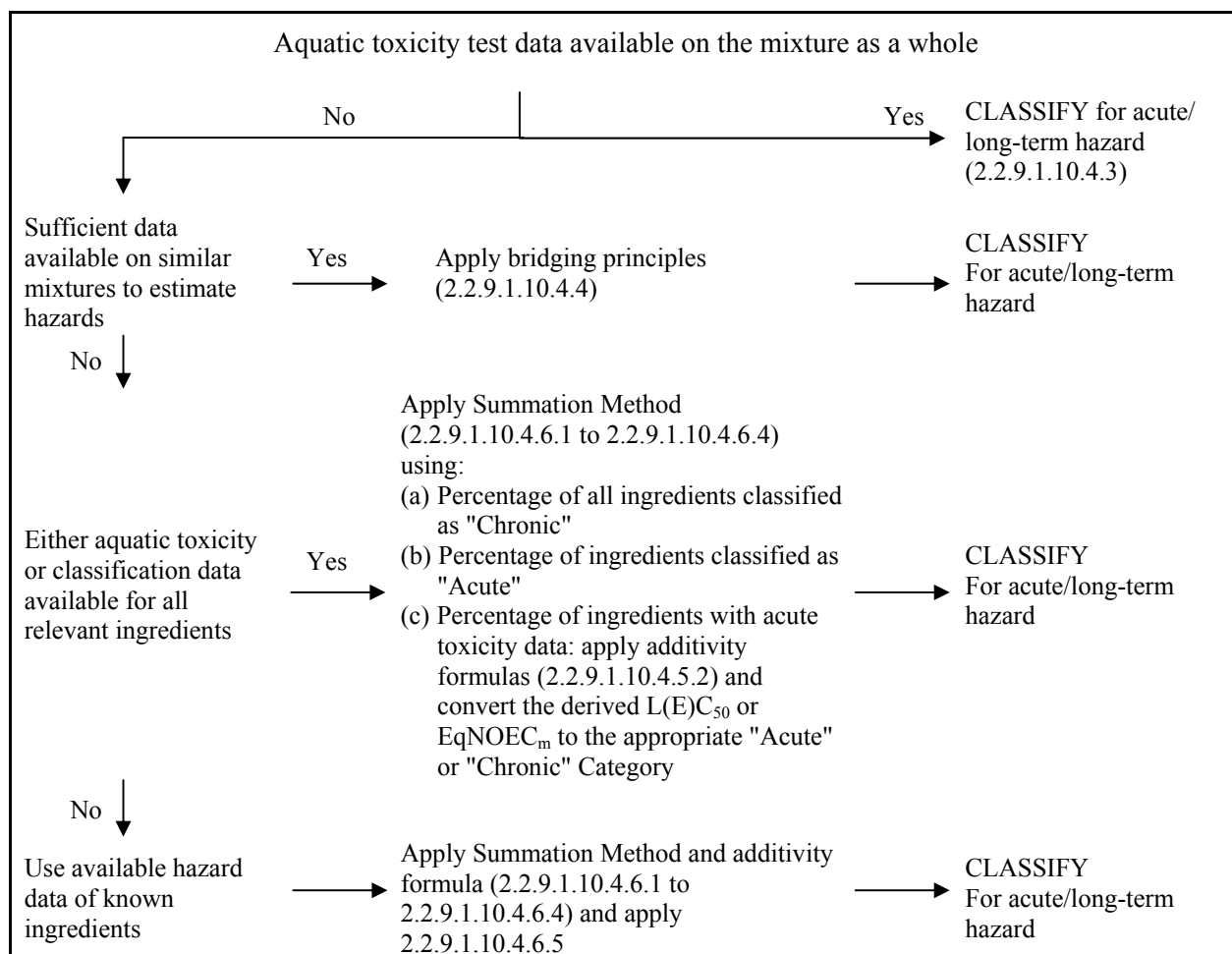

2.2.9.1.10.4.3 Classification of mixtures when toxicity data are available for the complete mixture

2.2.9.1.10.4.3.1 When the mixture as a whole has been tested to determine its aquatic toxicity, this information shall be used for classifying the mixture according to the criteria that have been agreed for substances. The classification is normally based on the data for fish, crustacea and algae/plants (see 2.2.9.1.10.2.3 and 2.2.9.1.10.2.4). When adequate acute or chronic data for the mixture as a whole are lacking, "bridging principles" or "summation method" shall be applied (see 2.2.9.1.10.4.4 to 2.2.9.1.10.4.6).

2.2.9.1.10.4.3.2 The long-term hazard classification of mixtures requires additional information on degradability and in certain cases bioaccumulation. There are no degradability and bioaccumulation data for mixtures as a whole. Degradability and bioaccumulation tests for mixtures are not used as they are usually difficult to interpret, and such tests may be meaningful only for single substances.

2.2.9.1.10.4.3.3 Classification for category Acute 1

- (a) When there are adequate acute toxicity test data (LC_{50} or EC_{50}) available for the mixture as a whole showing $L(E)C_{50} \leq 1$ mg/l:

Classify the mixture as Acute 1 in accordance with Table 2.2.9.1.10.3.1 (a);

- (b) When there are acute toxicity test data ($LC_{50}(s)$ or $EC_{50}(s)$) available for the mixture as a whole showing $L(E)C_{50}(s) > 1$ mg/l, or above the water solubility:

No need to classify for acute hazard under ADR.

2.2.9.1.10.4.3.4 Classification for categories Chronic 1 and 2

- (a) When there are adequate chronic toxicity data (EC_x or NOEC) available for the mixture as a whole showing EC_x or NOEC of the tested mixture ≤ 1 mg/l:

(i) classify the mixture as Chronic 1 or 2 in accordance with Table 2.2.9.1.10.3.1 (b) (ii) (rapidly degradable) if the available information allows the conclusion that all relevant ingredients of the mixture are rapidly degradable;

(ii) classify the mixture as Chronic 1 or 2 in all other cases in accordance with Table 2.2.9.1.10.3.1 (b) (i) (non-rapidly degradable);

- (b) When there are adequate chronic toxicity data (EC_x or NOEC) available for the mixture as a whole showing $EC_x(s)$ or NOEC(s) of the tested mixture > 1 mg/l or above the water solubility:

No need to classify for long-term hazard under ADR.

2.2.9.1.10.4.4 Classification of mixtures when toxicity data are not available for the complete mixture: bridging principles

2.2.9.1.10.4.4.1 Where the mixture itself has not been tested to determine its aquatic environmental hazard, but there are sufficient data on the individual ingredients and similar tested mixtures to adequately characterise the hazards of the mixture, these data shall be used in accordance with the following agreed bridging rules. This ensures that the classification process uses the available data to the greatest extent possible in characterising the hazards of the mixture without the necessity for additional testing in animals.

2.2.9.1.10.4.4.2 Dilution

Where a new mixture is formed by diluting a tested mixture or a substance with a diluent which has an equivalent or lower aquatic hazard classification than the least toxic original ingredient and which is not expected to affect the aquatic hazards of other ingredients, then the resulting mixture shall be classified as equivalent to the original tested mixture or substance. Alternatively, the method explained in 2.2.9.1.10.4.5 may be applied.

2.2.9.1.10.4.4.3 Batching

The aquatic hazard classification of a tested production batch of a mixture shall be assumed to be substantially equivalent to that of another untested production batch of the same commercial product when produced by or under the control of the same manufacturer, unless there is reason to believe there is significant variation such that the aquatic hazard classification of the untested batch has changed. If the latter occurs, new classification is necessary.

2.2.9.1.10.4.4.4 Concentration of mixtures which are classified with the most severe classification categories (Chronic 1 and Acute 1)

If a tested mixture is classified as Chronic 1 and/or Acute 1, and the ingredients of the mixture which are classified as Chronic 1 and/or Acute 1 are further concentrated, the more concentrated untested mixture shall be classified with the same classification category as the original tested mixture without additional testing.

2.2.9.1.10.4.4.5 Interpolation within one toxicity category

For three mixtures (A, B and C) with identical ingredients, where mixtures A and B have been tested and are in the same toxicity category, and where untested mixture C has the same toxicologically active ingredients as mixtures A and B but has concentrations of toxicologically active ingredients intermediate to the concentrations in mixtures A and B, then mixture C is assumed to be in the same category as A and B.

2.2.9.1.10.4.4.6 Substantially similar mixtures

Given the following:

- (a) Two mixtures:
 - (i) A + B;
 - (ii) C + B;
- (b) The concentration of ingredient B is essentially the same in both mixtures;
- (c) The concentration of ingredient A in mixture (i) equals that of ingredient C in mixture (ii);
- (d) Data on aquatic hazards for A and C are available and are substantially equivalent, i.e. they are in the same hazard category and are not expected to affect the aquatic toxicity of B.

If mixture (i) or (ii) is already classified based on test data, then the other mixture can be assigned the same hazard category.

2.2.9.1.10.4.5 Classification of mixtures when toxicity data are available for all ingredients or only for some ingredients of the mixture

2.2.9.1.10.4.5.1 The classification of a mixture shall be based on summation of the concentrations of its classified ingredients. The percentage of ingredients classified as "Acute" or "Chronic" will feed straight into the summation method. Details of the summation method are described in 2.2.9.1.10.4.6.1 to 2.2.9.1.10.4.6.4.

2.2.9.1.10.4.5.2 Mixtures may be made of a combination of both ingredients that are classified (as Acute 1 and/or Chronic 1, 2) and those for which adequate toxicity test data are available. When adequate toxicity data are available for more than one ingredient in the mixture, the combined toxicity of those ingredients shall be calculated using the following additivity formulas (a) or (b), depending on the nature of the toxicity data:

- (a) Based on acute aquatic toxicity:

$$\frac{\sum C_i}{L(E)C_{50m}} = \sum_n \frac{C_i}{L(E)C_{50i}}$$

where:

- C_i = concentration of ingredient i (mass percentage);
 $L(E)C_{50i}$ = LC_{50} or EC_{50} for ingredient i (mg/l);
 n = number of ingredients, and i is running from 1 to n;
 $L(E)C_{50m}$ = $L(E)C_{50}$ of the part of the mixture with test data;

The calculated toxicity shall be used to assign that portion of the mixture an acute hazard category which is then subsequently used in applying the summation method;

- (b) Based on chronic aquatic toxicity:

$$\frac{\sum C_i + \sum C_j}{EqNOEC_m} = \sum_n \frac{C_i}{NOEC_i} + \sum_n \frac{C_j}{0.1 \cdot NOEC_j}$$

where:

- C_i = concentration of ingredient i (mass percentage) covering the rapidly degradable ingredients;
 C_j = concentration of ingredient j (mass percentage) covering the non rapidly degradable ingredients;
 $NOEC_i$ = NOEC (or other recognized measures for chronic toxicity) for ingredient i covering the rapidly degradable ingredients, in mg/l;
 $NOEC_j$ = NOEC (or other recognized measures for chronic toxicity) for ingredient j covering the non-rapidly degradable ingredients, in mg/l;
 n = number of ingredients, and i and j are running from 1 to n;
 $EqNOEC_m$ = equivalent NOEC of the part of the mixture with test data;

The equivalent toxicity thus reflects the fact that non-rapidly degrading substances are classified one hazard category level more "severe" than rapidly degrading substances.

The calculated equivalent toxicity shall be used to assign that portion of the mixture a long-term hazard category, in accordance with the criteria for rapidly degradable substances (Table 2.2.9.1.10.3.1 (b) (ii)), which is then subsequently used in applying the summation method.

2.2.9.1.10.4.5.3 When applying the additivity formula for part of the mixture, it is preferable to calculate the toxicity of this part of the mixture using for each ingredient toxicity values that relate to the same taxonomic group (i.e. fish, crustacea or algae) and then to use the highest toxicity (lowest value) obtained (i.e. use the most sensitive of the three groups). However, when toxicity data for each ingredient are not available in the same taxonomic group, the toxicity value of each ingredient shall be selected in the same manner that toxicity values are selected for the classification of substances, i.e. the higher toxicity (from the most sensitive test organism) is used. The calculated acute and chronic toxicity shall then be used to classify this part of the mixture as Acute 1 and/or Chronic 1 or 2 using the same criteria described for substances.

2.2.9.1.10.4.5.4 If a mixture is classified in more than one way, the method yielding the more conservative result shall be used.

2.2.9.1.10.4.6 Summation method

2.2.9.1.10.4.6.1 Classification procedure

In general a more severe classification for mixtures overrides a less severe classification, e.g. a classification with Chronic 1 overrides a classification with Chronic 2. As a consequence the classification procedure is already completed if the results of the classification is Chronic 1. A more severe classification than Chronic 1 is not possible; therefore, it is not necessary to pursue the classification procedure further.

2.2.9.1.10.4.6.2 Classification for category Acute 1

2.2.9.1.10.4.6.2.1 First, all ingredients classified as Acute 1 are considered. If the sum of the concentrations (in %) of these ingredients is greater than or equal to 25% the whole mixture shall be classified as Acute 1. If the result of the calculation is a classification of the mixture as Acute 1, the classification process is completed.

2.2.9.1.10.4.6.2.2 The classification of mixtures for acute hazards based on this summation of the concentrations of classified ingredients is summarized in Table 2.2.9.1.10.4.6.2.2 below.

Table 2.2.9.1.10.4.6.2.2: Classification of a mixture for acute hazards based on summation of the concentrations of classified ingredients

Sum of the concentrations (in %) of ingredients classified as:	Mixture classified as:
Acute 1 \times M ^a \geq 25%	Acute 1

^a For explanation of the M factor, see 2.2.9.1.10.4.6.4.

2.2.9.1.10.4.6.3 Classification for categories Chronic 1 and 2

2.2.9.1.10.4.6.3.1 First, all ingredients classified as Chronic 1 are considered. If the sum of the concentrations (in %) of these ingredients is greater than or equal to 25% the mixture shall be classified as Chronic 1. If the result of the calculation is a classification of the mixture as Chronic 1 the classification procedure is completed.

2.2.9.1.10.4.6.3.2 In cases where the mixture is not classified as Chronic 1, classification of the mixture as Chronic 2 is considered. A mixture shall be classified as Chronic 2 if 10 times the sum of the concentrations (in %) of all ingredients classified as Chronic 1 plus the sum of the concentrations (in %) of all ingredients classified as Chronic 2 is greater than or equal to 25%. If the result of the calculation is classification of the mixture as Chronic 2, the classification process is completed.

2.2.9.1.10.4.6.3.3 The classification of mixtures for long-term hazards based on this summation of the concentrations of classified ingredients is summarized in Table 2.2.9.1.10.4.6.3.3 below.

Table 2.2.9.1.10.4.6.3.3: Classification of a mixture for long-term hazards based on summation of the concentrations of classified ingredients

Sum of the concentrations (in %) of ingredients classified as:	Mixture classified as:
Chronic 1 \times M ^a \geq 25%	Chronic 1
(M \times 10 \times Chronic 1) + Chronic 2 \geq 25%	Chronic 2

^a For explanation of the M factor, see 2.2.9.1.10.4.6.4.

2.2.9.1.10.4.6.4 Mixtures with highly toxic ingredients

Acute 1 or Chronic 1 ingredients with acute toxicities well below 1 mg/l and/or chronic toxicities well below 0.1 mg/l (if non-rapidly degradable) and 0.01 mg/l (if rapidly degradable) may influence the toxicity of the mixture and are given increased weight in applying the summation method. When a mixture contains ingredients classified as acute or Chronic 1, the tiered approach described in 2.2.9.1.10.4.6.2 and 2.2.9.1.10.4.6.3 shall be applied using a weighted sum by multiplying the concentrations of Acute 1 and Chronic 1 ingredients by a factor, instead of merely adding up the percentages. This means that the concentration of "Acute 1" in the left column of Table 2.2.9.1.10.4.6.2.2 and the concentration of "Chronic 1" in the left column of Table 2.2.9.1.10.4.6.3.3 are multiplied by the appropriate multiplying factor. The multiplying factors to be applied to these ingredients are defined using the toxicity value, as summarised in Table 2.2.9.1.10.4.6.4 below. Therefore, in order to classify a mixture containing Acute 1 and/or Chronic 1 ingredients, the classifier needs to be informed of the value of the M factor in order to apply the summation method. Alternatively, the additivity formula (see 2.2.9.1.10.4.5.2) may be used when toxicity data are available for all highly toxic ingredients in the mixture and there is convincing evidence that all other ingredients, including those for which specific acute and/or chronic toxicity data are not available, are of low or no toxicity and do not significantly contribute to the environmental hazard of the mixture.

Table 2.2.9.1.10.4.6.4: Multiplying factors for highly toxic ingredients of mixtures

Acute toxicity L(E)C ₅₀ value	M factor	Chronic toxicity NOEC value	M factor	
			NRD ^a ingredients	RD ^b ingredients
0.1 < L(E)C ₅₀ ≤ 1	1	0.01 < NOEC ≤ 0.1	1	–
0.01 < L(E)C ₅₀ ≤ 0.1	10	0.001 < NOEC ≤ 0.01	10	1
0.001 < L(E)C ₅₀ ≤ 0.01	100	0.0001 < NOEC ≤ 0.001	100	10
0.0001 < L(E)C ₅₀ ≤ 0.001	1 000	0.00001 < NOEC ≤ 0.0001	1 000	100
0.00001 < L(E)C ₅₀ ≤ 0.0001	10 000	0.000001 < NOEC ≤ 0.00001	10 000	1 000
(continue in factor 10 intervals)		(continue in factor 10 intervals)		

^a *Non-rapidly degradable.*

^b *Rapidly degradable.*

2.2.9.1.10.4.6.5 Classification of mixtures with ingredients without any useable information

In the event that no useable information on acute and/or chronic aquatic toxicity is available for one or more relevant ingredients, it is concluded that the mixture cannot be attributed (a) definitive hazard category(ies). In this situation the mixture shall be classified based on the known ingredients only with the additional statement that: "x percent of the mixture consists of ingredient(s) of unknown hazard to the aquatic environment.

2.2.9.1.10.5 Substances or mixtures classified as environmentally hazardous substances (aquatic environment) on the basis of Regulation 1272/2008/EC¹⁶

If data for classification according to the criteria of 2.2.9.1.10.3 and 2.2.9.1.10.4 are not available, a substance or mixture:

- (a) Shall be classified as an environmentally hazardous substance (aquatic environment) if it has to be assigned category(ies) Aquatic Acute 1, Aquatic Chronic 1 or Aquatic Chronic 2 according to Regulation 1272/2008/EC¹⁶ or, if still relevant according to the said Regulation, risk phrase(s) R50, R50/53 or R51/53 according to the Directives 67/548/EEC³ or 1999/45/EC⁴;
- (b) May be regarded as not being an environmentally hazardous substance (aquatic environment) if it does not have to be assigned such a risk phrase or category according to the said Directives or Regulation.

2.2.9.1.10.6 Assignment of substances or mixtures classified as environmentally hazardous substances (aquatic environment) according to the provisions in 2.2.9.1.10.3, 2.2.9.1.10.4 or 2.2.9.1.10.5

Substances or mixtures classified as environmentally hazardous substances (aquatic environment), not otherwise classified under ADR shall be designated:

UN No. 3077 ENVIRONMENTALLY HAZARDOUS SUBSTANCE, SOLID, N.O.S.; or

UN No. 3082 ENVIRONMENTALLY HAZARDOUS SUBSTANCE, LIQUID, N.O.S.

They shall be assigned to packing group III.

Genetically modified microorganisms or organisms

2.2.9.1.11 Genetically modified microorganisms (GMMOs) and genetically modified organisms (GMOs) are microorganisms and organisms in which genetic material has been purposely altered through genetic engineering in a way that does not occur naturally. They are assigned to Class 9 (UN No. 3245) if they do not meet the definition of toxic substances or of infectious substances, but are capable of altering animals, plants or microbiological substances in a way not normally the result of natural reproduction.

NOTE 1: *GMMOs and GMOs which are infectious are substances of Class 6.2, UN Nos. 2814, 2900 or 3373.*

¹⁶ Regulation 1272/2008/EC of the European Parliament and of the Council of 16 December 2008 on classification, labelling and packaging of substances and mixtures (Official Journal of the European Union No. L 353 of 30 December 2008).

³ Council Directive 67/548/EEC of 27 June 1967 on the approximation of laws, regulations and administrative provisions relating to the classification, packaging and labelling of dangerous substances (Official Journal of the European Communities No. L 196 of 16 August 1967).

⁴ Directive 1999/45/EC of the European Parliament and of the Council of 31 May 1999 concerning the approximation of the laws, regulations and administrative provisions of the Member States relating to the classification, packaging and labelling of dangerous preparations (Official Journal of the European Communities No. L 200 of 30 July 1999).

NOTE 2: *GMMOs or GMOs are not subject to the provisions of ADR when authorized for use by the competent authorities of the countries of origin, transit and destination*¹⁷.

NOTE 3: *Live animals shall not be used to carry genetically modified microorganisms classified in Class 9 unless the substance can be carried no other way. Genetically modified live animals shall be carried under terms and conditions of the competent authorities of the countries of origin and destination.*

2.2.9.1.12 (Deleted)

Elevated temperature substances

2.2.9.1.13 Elevated temperature substances include substances which are carried or handed over for carriage in the liquid state at or above 100 °C and, in the case of those with a flash-point, below their flash-point. They also include solids which are carried or handed over for carriage at or above 240 °C.

NOTE: *Elevated temperature substances may be assigned to Class 9 only if they do not meet the criteria of any other class.*

Other substances presenting a danger during carriage but not meeting the definitions of another class.

2.2.9.1.14 The following other miscellaneous substances not meeting the definitions of another class are assigned to Class 9:

Solid ammonia compounds having a flash-point below 60 °C;
Low hazard dithionites;
Highly volatile liquids;
Substances emitting noxious fumes;
Substances containing allergens;
Chemical kits and first aid kits;

NOTE: *UN No. 1845 carbon dioxide, solid (dry ice), UN No. 2071 ammonium nitrate fertilizers, UN No. 2216 fish meal (fish scrap), stabilized, UN No. 2807 magnetized material, UN No. 3166 engine, internal combustion or 3166 vehicle, flammable gas powered or 3166 vehicle, flammable liquid powered or 3166 engine, fuel cell, flammable gas powered or 3166 engine, fuel cell, flammable liquid powered or 3166 vehicle, fuel cell, flammable gas powered or 3166 vehicle, fuel cell, flammable liquid powered, UN No. 3171 battery-powered vehicle or 3171 battery-powered equipment (wet battery), UN No. 3334 aviation regulated liquid, n.o.s., UN No. 3335 aviation regulated solid, n.o.s. and UN No. 3363 dangerous goods in machinery or dangerous goods in apparatus listed in the UN Model Regulations, are not subject to the provisions of ADR.*

Assignment of the packing groups

2.2.9.1.15 When indicated in column (4) of Table A of Chapter 3.2, substances and articles of Class 9 are assigned to one of the following packing groups according to their degree of danger:

Packing group II: substances presenting medium danger;
Packing group III: substances presenting low danger.

¹⁷ See in particular Part C of Directive 2001/18/EC of the European Parliament and of the Council on the deliberate release into the environment of genetically modified organisms and repealing Council Directive 90/220/EEC (Official Journal of the European Communities, No. L 106, of 17 April 2001, pp. 8-14), which sets out the authorization procedures for the European Community.

2.2.9.2 ***Substances and articles not accepted for carriage***

The following substances and articles shall not be accepted for carriage:

- Lithium batteries which do not meet the relevant conditions of special provisions 188, 230 or 636 of Chapter 3.3;

- Uncleaned empty containment vessels for apparatus such as transformers, condensers and hydraulic apparatus containing substances assigned to UN Nos. 2315, 3151, 3152 or 3432.

2.2.9.3 *List of entries*

Substances which, on inhalation as fine dust, may endanger health		M1	2212 BLUE ASBESTOS (crocidolite) or 2212 BROWN ASBESTOS (amosite, mysorite) 2590 WHITE ASBESTOS (chrysotile, actinolite, anthophyllite, tremolite)
Substances and apparatus which, in the event of fire, may form dioxins		M2	2315 POLYCHLORINATED BIPHENYLS, LIQUID 3432 POLYCHLORINATED BIPHENYLS, SOLID 3151 POLYHALOGENATED BIPHENYLS, LIQUID or 3151 POLYHALOGENATED TERPHENYLS, LIQUID 3152 POLYHALOGENATED BIPHENYLS, SOLID or 3152 POLYHALOGENATED TERPHENYLS, SOLID
Substances evolving flammable vapour		M3	2211 POLYMERIC BEADS, EXPANDABLE, evolving flammable vapour 3314 PLASTICS MOULDING COMPOUND in dough, sheet or extruded rope form evolving flammable vapour
Lithium batteries		M4	3090 LITHIUM METAL BATTERIES (including lithium alloy batteries) 3091 LITHIUM METAL BATTERIES CONTAINED IN EQUIPMENT (including lithium alloy batteries) or 3091 LITHIUM METAL BATTERIES PACKED WITH EQUIPMENT (including lithium alloy batteries) 3480 LITHIUM ION BATTERIES (including lithium ion polymer batteries) 3481 LITHIUM ION BATTERIES CONTAINED IN EQUIPMENT (including lithium ion polymer batteries) or 3481 LITHIUM ION BATTERIES PACKED WITH EQUIPMENT (including lithium ion polymer batteries)
Live-saving appliances		M5	2990 LIFE-SAVING APPLIANCES, SELF-INFLATING 3072 LIFE-SAVING APPLIANCES NOT SELF-INFLATING containing dangerous goods as equipment 3268 AIR BAG INFLATORS or 3268 AIR BAG MODULES or 3268 SEAT-BELT PRETENSIONERS
Environmentally hazardous substances	pollutant to the aquatic environment, liquid	M6	3082 ENVIRONMENTALLY HAZARDOUS SUBSTANCE, LIQUID, N.O.S.
	pollutant to the aquatic environment, solid	M7	3077 ENVIRONMENTALLY HAZARDOUS SUBSTANCE, SOLID, N.O.S.
Elevated temperature substances	genetically modified micro-organisms and organisms	M8	3245 GENETICALLY MODIFIED MICROORGANISMS or 3245 GENETICALLY MODIFIED ORGANISMS
	liquid	M9	3257 ELEVATED TEMPERATURE LIQUID, N.O.S., at or above 100 °C and below its flash-point (including molten metal, molten salts, etc.)
	solid	M10	3258 ELEVATED TEMPERATURE SOLID, N.O.S., at or above 240 °C
Other substances or articles presenting a danger during carriage, but not meeting the definitions of another class		M11	No collective entry available. Only substances listed in Table A of Chapter 3.2 are subject to the provisions for Class 9 under this classification code, as follows: 1841 ACETALDEHYDE AMMONIA 1931 ZINC DITHIONITE (ZINC HYDROSULPHITE) 1941 DIBROMODIFLUOROMETHANE 1990 BENZALDEHYDE 2969 CASTOR BEANS, or 2969 CASTOR MEAL, or 2969 CASTOR POMACE, or 2969 CASTOR FLAKE 3316 CHEMICAL KIT, or 3316 FIRST AID KIT 3359 FUMIGATED UNIT

CHAPTER 2.3

TEST METHODS

2.3.0 General

Unless otherwise provided for in Chapter 2.2 or in this Chapter, the test methods to be used for the classification of dangerous goods are those described in the Manual of Tests and Criteria.

2.3.1 Exudation test for blasting explosives of Type A

2.3.1.1 Blasting explosives of type A (UN No. 0081) shall, if they contain more than 40% liquid nitric ester, in addition to the testing specified in the Manual of Tests and Criteria, satisfy the following exudation test.

2.3.1.2 The apparatus for testing blasting explosive for exudation (figs. 1 to 3) consists of a hollow bronze cylinder. This cylinder, which is closed at one end by a plate of the same metal, has an internal diameter of 15.7 mm and a depth of 40 mm. It is pierced by 20 holes 0.5 mm in diameter (four sets of five holes) on the circumference. A bronze piston, cylindrically fashioned over a length of 48 mm and having a total length of 52 mm, slides into the vertically placed cylinder. The piston, whose diameter is 15.6 mm, is loaded with a mass of 220 g so that a pressure of 120 kPa (1.20 bar) is exerted on the base of the cylinder.

2.3.1.3 A small plug of blasting explosive weighing 5 to 8 g, 30 mm long and 15 mm in diameter, is wrapped in very fine gauze and placed in the cylinder; the piston and its loading mass are then placed on it so that the blasting explosive is subjected to a pressure of 120 kPa (1.20 bar). The time taken for the appearance of the first signs of oily droplets (nitroglycerine) at the outer orifices of the cylinder holes is noted.

2.3.1.4 The blasting explosive is considered satisfactory if the time elapsing before the appearance of the liquid exudations is more than five minutes, the test having been carried out at a temperature of 15 °C to 25 °C.

Test of blasting explosive for exudation

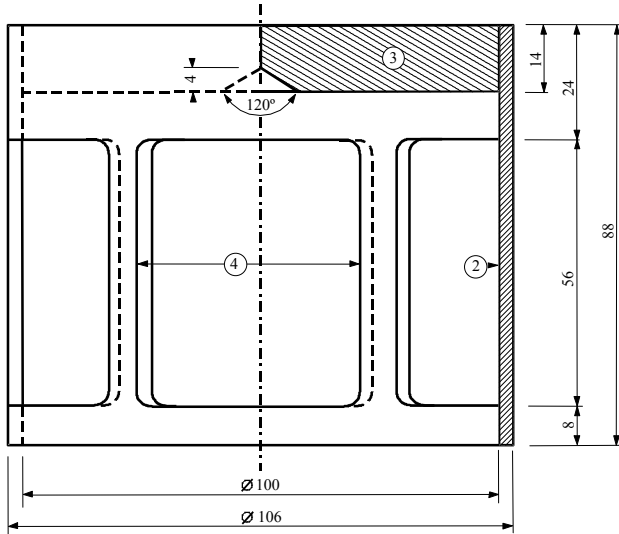

Fig.1: Bell-form charge, mass 2220 g, capable of being suspended from a bronze piston

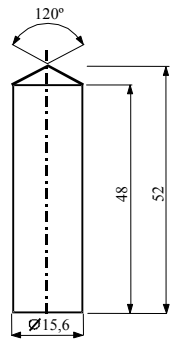

Fig.2: Cylindrical bronze piston, dimensions in mm

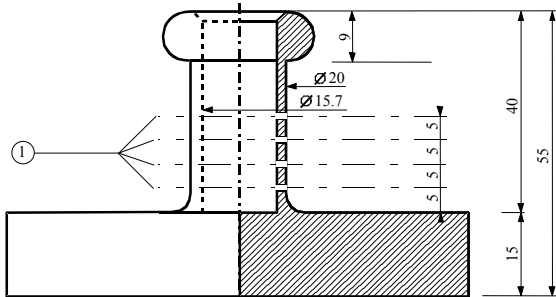

Fig.3: Hollow bronze cylinder, closed at one end; Plan and cut dimensions in mm

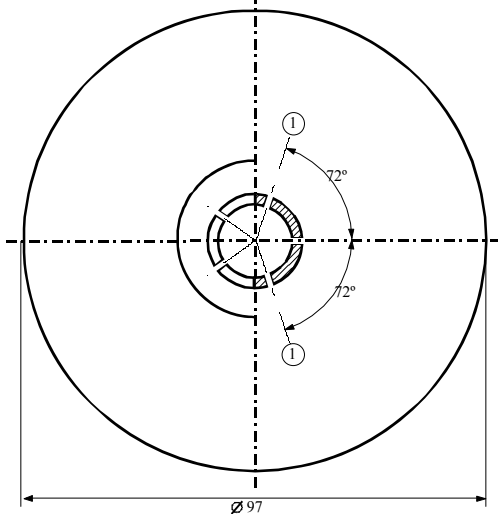

Fig. 1 to 3

- (1) 4 series of 5 holes at 0.5 N
- (2) copper
- (3) iron plate with centre cone at the inferior face
- (4) 4 openings, approximately 46x56, set at even intervals on the periphery

2.3.2 Tests relating to nitrated cellulose mixtures of Class 4.1

- 2.3.2.1 Nitrocellulose heated for half an hour at 132 °C shall not give off visible yellowish-brown nitrous fumes (nitrous gases). The ignition temperature shall be above 180 °C. See 2.3.2.3 to 2.3.2.8, 2.3.2.9 (a) and 2.3.2.10 below.
- 2.3.2.2 3 g of plasticized nitrocellulose, heated for one hour at 132 °C, shall not give off visible yellowish-brown nitrous fumes (nitrous gases). The ignition temperature shall be above 170 °C. See 2.3.2.3 to 2.3.2.8, 2.3.2.9 (b) and 2.3.2.10 below.
- 2.3.2.3 The test procedures set out below are to be applied when differences of opinion arise as to the acceptability of substances for carriage by road.
- 2.3.2.4 If other methods or test procedures are used to verify the conditions of stability prescribed above in this section, those methods shall lead to the same findings as could be reached by the methods specified below.
- 2.3.2.5 In carrying out the stability tests by heating described below, the temperature of the oven containing the sample under test shall not deviate by more than 2 °C from the prescribed temperature; the prescribed duration of a 30-minute or 60-minute test shall be observed to within two minutes. The oven shall be such that the required temperature is restored not more than five minutes after insertion of the sample.
- 2.3.2.6 Before undergoing the tests in 2.3.2.9 and 2.3.2.10, the samples shall be dried for not less than 15 hours at the ambient temperature in a vacuum desiccator containing fused and granulated calcium chloride, the sample substance being spread in a thin layer; for this purpose, substances which are neither in powder form nor fibrous shall be ground, or grated, or cut into small pieces. The pressure in the desiccator shall be brought below 6.5 kPa (0.065 bar).
- 2.3.2.7 Before being dried as prescribed in 2.3.2.6 above, substances conforming to 2.3.2.2 shall undergo preliminary drying in a well-ventilated oven, with its temperature set at 70 °C, until the loss of mass per quarter-hour is less than 0.3% of the original mass.
- 2.3.2.8 Weakly nitrated nitrocellulose conforming to 2.3.2.1 shall first undergo preliminary drying as prescribed in 2.3.2.7 above; drying shall then be completed by keeping the nitrocellulose for at least 15 hours over concentrated sulphuric acid in a desiccator.

2.3.2.9 Test of chemical stability under heat

(a) *Test of the substance listed in paragraph 2.3.2.1 above.*

(i) In each of two glass test tubes having the following dimensions:

length	350 mm
internal diameter	16 mm
thickness of wall	1.5 mm

is placed 1 g of substance dried over calcium chloride (if necessary the drying shall be carried out after reducing the substance to pieces weighing not more than 0.05 g each).

Both test tubes, completely covered with loose-fitting closures, are then so placed in an oven that at least four-fifths of their length is visible, and are kept at a constant temperature of 132 °C for 30 minutes. It is observed whether nitrous gases in the form of yellowish-brown fumes clearly visible against a white background are given off during this time;

(ii) In the absence of such fumes the substance is deemed to be stable;

- (b) *Test of plasticized nitrocellulose (see 2.3.2.2)*
- (i) 3 g of plasticized nitrocellulose are placed in glass test tubes, similar to those referred to in (a), which are then placed in an oven kept at a constant temperature of 132 °C;
 - (ii) The test tubes containing the plasticized nitrocellulose are kept in the oven for one hour. During this time no yellowish-brown nitrous fumes (nitrous gases) shall be visible. Observation and appraisal as in (a).

2.3.2.10 Ignition temperature (see 2.3.2.1 and 2.3.2.2)

- (a) The ignition temperature is determined by heating 0.2 g of substance enclosed in a glass test tube immersed in a Wood's alloy bath. The test tube is placed in the bath when the latter has reached 100 °C. The temperature of the bath is then progressively increased by 5 °C per minute;
- (b) The test tubes must have the following dimensions:

length	125 mm
internal diameter	15 mm
thickness of wall	0.5 mm

and shall be immersed to a depth of 20 mm;
- (c) The test shall be repeated three times, the temperature at which ignition of the substance occurs, i.e., slow or rapid combustion, deflagration or detonation, being noted each time;
- (d) The lowest temperature recorded in the three tests is the ignition temperature.

2.3.3 Tests relating to flammable liquids of Classes 3, 6.1 and 8

2.3.3.1 Determination of flash-point

2.3.3.1.1 The following methods for determining the flash-point of flammable liquids may be used:

International standards:

ISO 1516 (Determination of flash/no flash – Closed cup equilibrium method)
ISO 1523 (Determination of flash point – Closed cup equilibrium method)
ISO 2719 (Determination of flash point – Pensky-Martens closed cup method)
ISO 13736 (Determination of flash point – Abel closed-cup method)
ISO 3679 (Determination of flash point – Rapid equilibrium closed cup method)
ISO 3680 (Determination of flash/no flash – Rapid equilibrium closed cup method)

National standards:

American Society for Testing Materials International, 100 Barr Harbor Drive, PO Box C700, West Conshohocken, Pennsylvania, USA 19428-2959:

ASTM D3828-07a, Standard Test Methods for Flash Point by Small Scale Closed-Cup Tester
ASTM D56-05, Standard Test Method for Flash Point by Tag Closed-Cup Tester
ASTM D3278-96(2004)e1, Standard Test Methods for Flash Point of Liquids by Small Scale Closed-Cup Apparatus
ASTM D93-08, Standard Test Methods for Flash Point by Pensky-Martens Closed-Cup Tester

Association française de normalisation, AFNOR, 11, rue de Pressensé, F-93571 La Plaine Saint-Denis Cedex:

French standard NF M 07 - 019
French standards NF M 07 - 011 / NF T 30 - 050 / NF T 66 - 009
French standard NF M 07 - 036

Deutsches Institut für Normung, Burggrafenstr. 6, D-10787 Berlin:

Standard DIN 51755 (flash-points below 65 °C)

State Committee of the Council of Ministers for Standardization, RUS-113813, GSP, Moscow, M-49 Leninsky Prospect, 9:

GOST 12.1.044-84

2.3.3.1.2 To determine the flash-point of paints, gums and similar viscous products containing solvents, only apparatus and test methods suitable for determining the flash-point for viscous liquids shall be used, in accordance with the following standards:

- (a) International Standard ISO 3679: 1983;
- (b) International Standard ISO 3680: 1983;
- (c) International Standard ISO 1523: 1983;
- (d) International standards EN ISO 13736 and EN ISO 2719, Method B.

2.3.3.1.3 The standards listed in 2.3.3.1.1 shall only be used for flash-point ranges which are specified therein. The possibility of chemical reactions between the substance and the sample holder shall be considered when selecting the standard to be used. The apparatus shall, as far as is consistent with safety, be placed in a draught-free position. For safety, a method utilizing a small sample size, around 2 ml, shall be used for organic peroxides and self-reactive substances (also known as "energetic" substances), or for toxic substances.

2.3.3.1.4 When the flash-point, determined by a non-equilibrium method is found to be 23 ± 2 °C or 60 ± 2 °C, it shall be confirmed for each temperature range by an equilibrium method.

2.3.3.1.5 In the event of a dispute as to the classification of a flammable liquid, the classification proposed by the consignor shall be accepted if a check-test of the flash-point, yields a result not differing by more than 2 °C from the limits (23 °C and 60 °C respectively) stated in 2.2.3.1. If the difference is more than 2 °C, a second check-test shall be carried out, and the lowest figure of the flash-points obtained in either check-test shall be adopted.

2.3.3.2 *Determination of initial boiling point*

The following methods for determining the initial boiling point of flammable liquids may be used:

International standards:

ISO 3924 (Petroleum products – Determination of boiling range distribution – Gas chromatography method)

ISO 4626 (Volatile organic liquids – Determination of boiling range of organic solvents used as raw materials)

ISO 3405 (Petroleum products – Determination of distillation characteristics at atmospheric pressure)

National standards:

American Society for Testing Materials International, 100 Barr Harbor Drive, PO Box C700, West Conshohocken, Pennsylvania, USA 19428-2959:

ASTM D86-07a, Standard Test Method for Distillation of Petroleum Products at Atmospheric Pressure

ASTM D1078-05, Standard Test Method for Distillation Range of Volatile Organic Liquids

Further acceptable methods:

Method A.2 as described in Part A of the Annex to Commission Regulation (EC) No 440/2008¹.

2.3.3.3 ***Test for determining peroxide content***

To determine the peroxide content of a liquid, the procedure is as follows:

A quantity p (about 5 g, weighed to the nearest 0.01 g) of the liquid to be titrated is placed in an Erlenmeyer flask; 20 cm³ of acetic anhydride and about 1 g of powdered solid potassium iodide are added; the flask is shaken and, after 10 minutes, heated for 3 minutes to about 60 °C. When it has been left to cool for 5 minutes, 25 cm³ of water are added. After this, it is left standing for half an hour, then the liberated iodine is titrated with a decinormal solution of sodium thiosulphate, no indicator being added; complete discoloration indicates the end of the reaction. If n is the number of cm³ of thiosulphate solution required, the percentage of peroxide (calculated as H₂O₂) present in the sample is obtained by the formula:

$$\frac{17n}{100p}$$

2.3.4 **Test for determining fluidity**

To determine the fluidity of liquid, viscous or pasty substances and mixtures, the following test method shall be used.

2.3.4.1 ***Test apparatus***

Commercial penetrometer conforming to ISO 2137:1985, with a guide rod of 47.5 g ± 0.05 g; sieve disc of duralumin with conical bores and a mass of 102.5 g ± 0.05 g (see Figure 1); penetration vessel with an inside diameter of 72 mm to 80 mm for reception of the sample.

2.3.4.2 ***Test procedure***

The sample is poured into the penetration vessel not less than half an hour before the measurement. The vessel is then hermetically closed and left standing until the measurement. The sample in the hermetically closed penetration vessel is heated to 35 °C ± 0.5 °C and is placed on the penetrometer table immediately prior to measurement (not more than two minutes). The point S of the sieve disc is then brought into contact with the surface of the liquid and the rate of penetration is measured.

¹ *Commission Regulation (EC) No 440/2008 of 30 May 2008 laying down test methods pursuant to Regulation (EC) No 1907/2006 of the European Parliament and of the Council on the Registration, Evaluation, Authorisation and Restriction of Chemicals (REACH) (Official Journal of the European Union, No. L 142 of 31.05.2008, p.1-739 and No. L 143 of 03.06.2008, p.55).*

2.3.4.3 *Evaluation of test results*

A substance is pasty if, after the centre S has been brought into contact with the surface of the sample, the penetration indicated by the dial gauge:

- (a) after a loading time of $5 \text{ s} \pm 0.1 \text{ s}$, is less than $15.0 \text{ mm} \pm 0.3 \text{ mm}$; or
- (b) after a loading time of $5 \text{ s} \pm 0.1 \text{ s}$, is greater than $15.0 \text{ mm} \pm 0.3 \text{ mm}$, but the additional penetration after another $55 \text{ s} \pm 0.5 \text{ s}$ is less than $5.0 \text{ mm} \pm 0.5 \text{ mm}$.

***NOTE:** In the case of samples having a flow point, it is often impossible to produce a steady level surface in the penetration vessel and, hence, to establish satisfactory initial measuring conditions for the contact of the point S. Furthermore, with some samples, the impact of the sieve disc can cause an elastic deformation of the surface and, in the first few seconds, simulate a deeper penetration. In all these cases, it may be appropriate to make the evaluation in paragraph (b) above.*

Figure 1 – Penetrometer

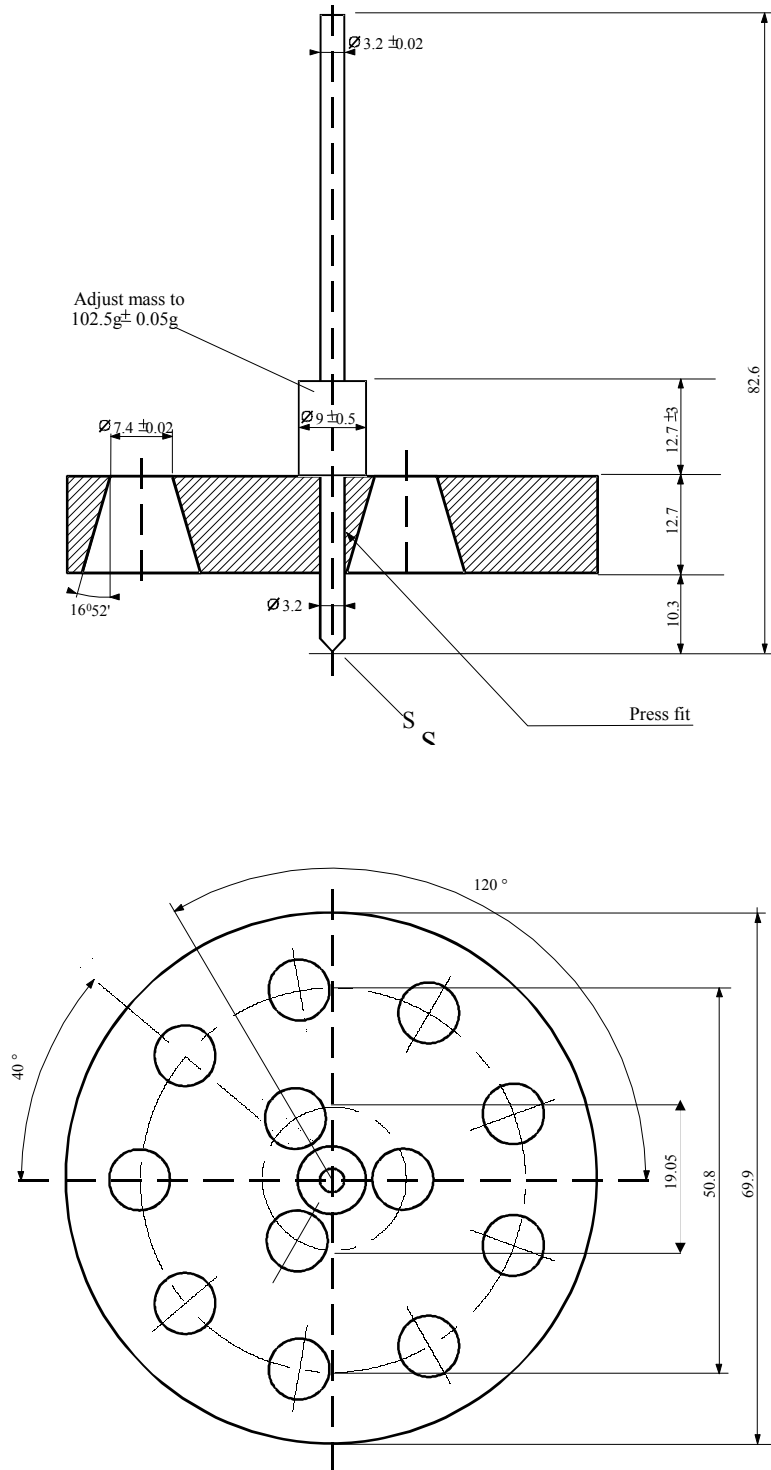

Tolerances not specified are ± 0.1 mm.

2.3.5 Classification of organometallic substances in Classes 4.2 and 4.3

Depending on their properties as determined in accordance with tests N.1 to N.5 of the Manual of Tests and Criteria, Part III, section 33, organometallic substances may be classified in Class 4.2 or 4.3, as appropriate, in accordance with the flowchart scheme given in Figure 2.3.5.

NOTE 1: *Depending on their other properties and on the precedence of hazard table (see 2.1.3.10), organometallic substances may have to be classified in other classes as appropriate.*

NOTE 2: *Flammable solutions with organometallic compounds in concentrations which are not liable to spontaneous combustion or, in contact with water, do not emit flammable gases in dangerous quantities, are substances of Class 3.*

Figure 2.3.5: Flowchart scheme for the classification of organometallic substances in Classes 4.2 and 4.3^b

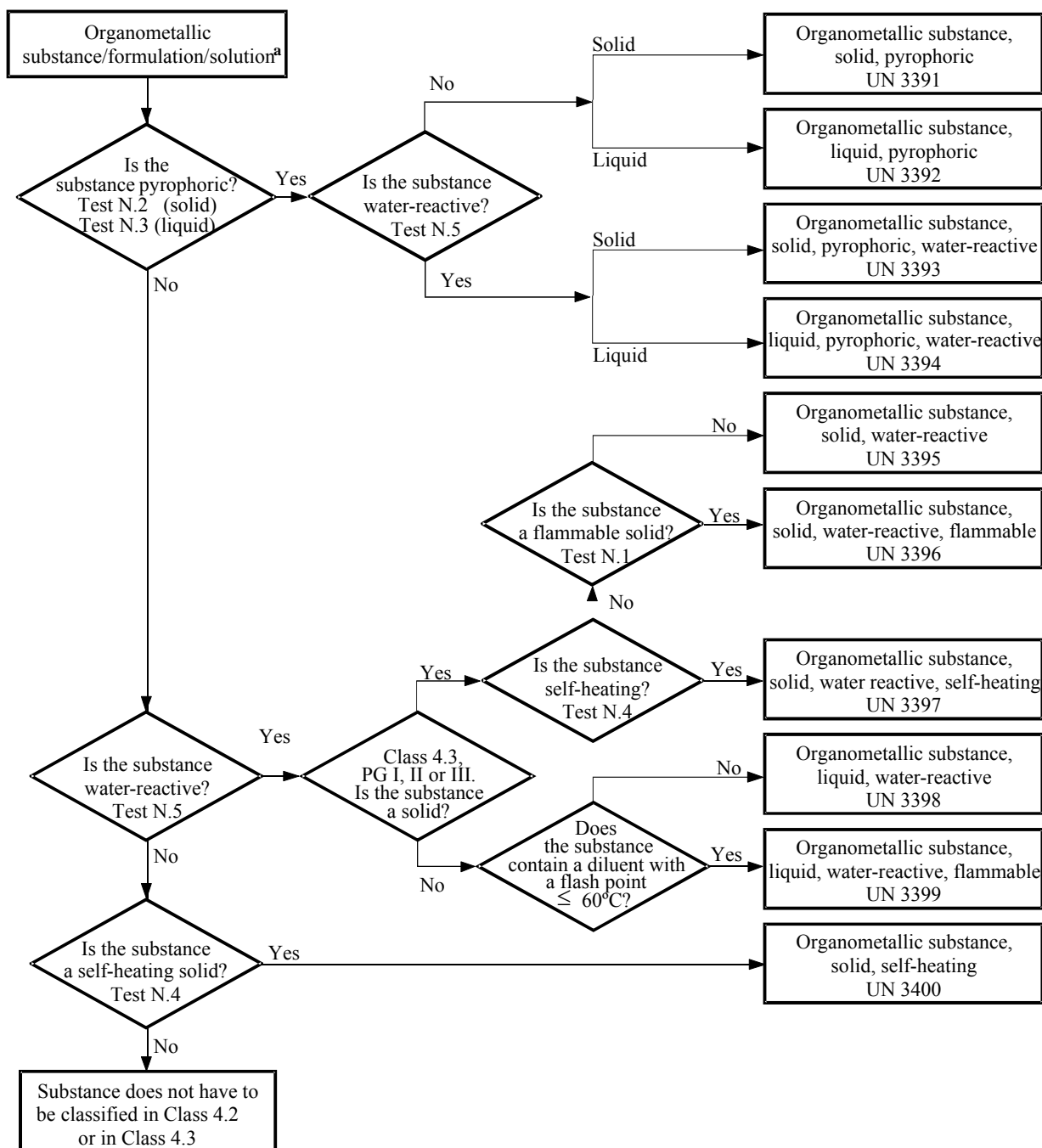

^a If applicable and testing is relevant, taking into account reactivity properties, class 6.1 and 8 properties should be considered according to the precedence of hazard table of 2.1.3.10.

^b Test methods N.1 to N.5 can be found in the Manual of Tests and Criteria, Part III, Section 33.