

*Review and Revision of UN-ECE Regulation 66.  
Consolidated Document presenting the work to date of the  
ad hoc Expert Group*

*This informal document is offered to the GRSG Group of WP29 of the UN-ECE as a summary of the work of the ad hoc Expert Group set up by the 73rd GRSG meeting 27-30 October 1997 to review UN-ECE Reg 66 and to offer proposals for its revision.*

*This informal document incorporates the following documents*

*TRANS/WP29/GRSG/2001/5*

*TRANS/WP29/GRSG/2001/6*

*TRANS/WP29/GRSG/2001/14*

*TRANS/WP29/GRSG/2001/18*

*and includes the results of the meeting of the ad hoc Expert Group in Frankfurt, Germany 22-24 November 2001.*

*Original text from Reg66 and Amendment 1 Supplement 1 is shown, together with proposed new text. This is shown by means of two different fonts*

*Four main areas remain to be agreed*

*Annex 8 – Calculation method based on quasi/static tests.*

*Annex 9 – Computer simulation of rollover test on complete vehicle.*

*The effect of fitment and use of seat-belts.*

*The extent to which one type approval can be applied to a family of existing and projected vehicle designs.*

*A further meeting of the ad hoc Expert Group is scheduled for 13/14 May 2002*

**AGREEMENT**

**CONCERNING THE ADOPTION OF UNIFORM CONDITIONS OF APPROVAL AND  
RECIPROCAL RECOGNITION OF APPROVAL FOR MOTOR VEHICLE EQUIPMENT AND  
PARTS**

done at Geneva on 20 March 1958

**Addendum 65: Regulation No. 66**

Date of entry into force as an annex to the Agreement:

1 December 1986

**UNIFORM PROVISIONS CONCERNING THE APPROVAL OF LARGE  
PASSENGER VEHICLES WITH REGARD TO THE STRENGTH OF  
THEIR SUPERSTRUCTURE**

**UNITED NATIONS**

**GE.87-20208/6902E**

**Regulation No. 66**

REGULATION

1. Scope
2. Definitions
3. Application for approval
4. Approval
5. General specifications and requirements
6. Modification and extension of approval of a vehicle type
7. Conformity of production
8. Penalties for non-conformity of production
9. Production definitely discontinued
10. Transitional provisions
11. Names and addresses of Technical Services"

ANNEXES

- Annex 1 Communication concerning the approval or refusal or extension or withdrawal of approval or production definitely discontinued of a vehicle type with regard to the strength of its superstructure pursuant to Regulation No.66
- Annex 2 Arrangement of the approval mark
- Annex 3 Determination of the position of the centre of gravity
- Annex 4 View points of the structural description
- Annex 5 Rollover test on complete vehicle
- Annex 6 Body section rollover test
- Annex 7 Quasi-Static Loading Test of Body Sections
- Annex 8 Calculation method based on quasi/static tests.
- Annex 9 Computer simulation of rollover test on complete vehicle

**1. SCOPE**

This Regulation applies to single-deck rigid or articulated vehicles designed and constructed for the carriage of more than 22 passengers, whether seated or standing, in addition to the driver and crew."

**2. DEFINITIONS**

For the purposes of the Regulation:

- 2.1. "Vehicle" means a bus or coach designed and equipped for transportation of passengers.

- 2.2 "Vehicle type" means a category of vehicles which do not differ essentially in respect of the constructional features specified in this Regulation;
- 2.3 "Approval of a vehicle" means the approval of vehicle type with regard to the construction features specified in this Regulation;
- 2.4 "Articulated vehicle" means a vehicle which consists of two or more rigid sections which articulate to one another, the passenger compartments of each section intercommunicate so that passengers can move freely between them; the rigid sections are permanently connected so that they can only be separated by an operation involving facilities which are normally only found in a workshop;
- 2.5 "Passenger compartment" means the space intended for passengers' use excluding any space occupied by fixed appliances such as bars, kitchenettes or toilets;
- 2.6 "Driver's compartment" means the space intended for the driver's exclusive use and containing the driver's seat, the steering wheel, controls, instruments and other devices necessary for driving the vehicle;
- 2.7 (**AMENDMENT 1 Supplement 1**) "Unladen kerb mass" ( $M_k$ ) (kg) means the mass of the vehicle in running order, unoccupied and unladen but with the addition of 75kg for the mass of the driver, the mass of fuel corresponding to 90 per cent of the capacity of the fuel tank specified by the manufacturer, and the masses of coolant, lubricant, tools and spare wheel, if any; "
- 2.8 "Residual space" means a space to be preserved in the passenger's and driver's compartment to provide better survival possibility for passengers, driver and crew in case of a rollover accident.
- 2.9 "Rollover test on a complete vehicle" means a realistic rollover simulation which is defined as basic test with full scale vehicle to prove the required strength of the superstructure.
- 2.10 "Tilting bench" means a technical device, an arrangement of tilting platform, ditch and concrete ground surface together, with the help of which a rollover test on complete vehicle can be performed.
- 2.11 "Tilting platform" means a rigid plane which can be rotated around a horizontal axis in order to tilt a vehicle either to determine the height of its centre of gravity or to perform a rollover test on complete vehicle.
- 2.12 "Energy balance" means applying the principle of energy conservation during the standard rollover test as a process. The total potential energy of the vehicle - through kinetic energy - is transformed into different kinds of mechanical work.
- 2.13 "Plastic zone" (PZ) means a special geometrically limited part of the superstructure in which, as the result of dynamic, impact forces:
- large scale plastic deformations are concentrated
  - essential distortion of the original shape (cross section, length, or other geometry) occurs
  - in consequence of local buckling, loss of stability ensues
  - due to deformation, a certain amount of kinetic energy is absorbed.
- 2.14 "Plastic hinge" (PH) means a simple plastic zone formed on a rod-like element (single tube, window column, etc).
- 2.15 "Reference energy" ( $E_R$ ) means the potential energy of the vehicle to be tested, measured in the starting, unstable position of the rollover process."
- 2.16 "Body work" means the complete structure of the vehicle in running order, including all the structural elements which form the passenger compartment, driver's compartment, baggage compartment and spaces for the mechanical units and components.

- 2.17. “Superstructure” means the load bearing components of the bodywork as defined by the manufacturer, containing those coherent parts and elements which contribute to the strength and energy absorbing capability of the bodywork., and preserve the residual space in the rollover test.
- 2.18. “Bay” means a structural section of the superstructure forming a closed loop between two planes which are perpendicular to the longitudinal axis of the vehicle. A bay contains one window (or door) pillar on each side of the vehicle as well as side wall elements, a section of the roof structure and a section of the floor and underfloor structure.
- 2.19. “Reinforced bay” means a bay containing additional strengthening elements; for example, stiffening ribs; partitions; wardrobe kitchen or toilet walls. These additional elements essentially change the structural behaviour of the bay. Specific examples of reinforced bays are the front and rear end structures of the vehicle body.
- 2.20. “Body section” means a structural unit, which represents one part of the superstructure for the purposes of an approval test. A body section contains at least two bays connected by representative connecting elements (side, roof, and underfloor, structures).
- 2.21. “Original body section” means a body section composed of two or more bays of exactly the same form and relative position, as they appear in the actual vehicle. All connecting elements between the bays are also arranged exactly as they appear in the actual vehicle.
- 2.22. “Artificial body section” means a body section built up from two or more bays but not in the same position, nor at the same distance from each other as in the actual vehicle. The connecting elements between these bays need not be identical with the real body work structure but shall be structurally equivalent.
- 2.23. “Rigid part” means a structural part or element which does not have significant deformation and energy absorption during the rollover test.
- 2.24. “Cant-rail” means the longitudinal structural part of the bodywork above the side windows including the curved transition to the roof structures. In the rollover test the cant-rail hits the ground first.
- 2.25. “Waist-rail” means the longitudinal structural part of the bodywork below the side windows. In the rollover test the waist-rail may be the second area to contact the ground after initial deformation of the vehicle cross-section.

### **3. APPLICATION FOR APPROVAL**

- 3.1. The application for approval of a vehicle type with regard to the strength of its superstructure shall be submitted by the vehicle manufacturer or by his duly accredited representative.
- 3.2. It shall be accompanied by three copies of each of the undermentioned documents and by the following particulars:
- 3.2.1. The main general parameters of the vehicle, especially:
- 3.2.1.1. general layout drawings of the vehicle, its bodywork and its interior arrangement with the main dimensions.
- 3.2.1.2. the unladen kerb mass of the vehicle (kg) and the associated axle loads (kg).
- 3.2.1.3. the exact position of the unladen vehicle’s centre of gravity (CG) together with the measuring report. To determine the centre of gravity position the measuring and calculation methods described in annex 3 shall be used.
- 3.2.1.4. the value of reference energy ( $E_R$ ) which is the product of the unladen kerb mass ( $M_K$ ), the gravity constant (g) and the height ( $h_o$ ) of centre of gravity with the vehicle in its unstable equilibrium position when starting the rollover test (see Figure 3).
- 3.2.2. Detailed description of the superstructure of the vehicle type, including its main dimensions, construction, joints and constituent materials (see Annex 4), especially:
- 3.2.2.1. drawing scheme of the superstructure.

- 3.2.2.2. drawings and description of those constructional elements which are part of the superstructure.
- 3.2.3. Detailed and exact drawing of the residual space. The manufacturer may define a residual space independent of the seating arrangement, as a worst case, if:
  - 3.2.3.1. the supporting and reinforcing effect of installed seats are not considered.
  - 3.2.3.2. the mass of the maximum possible number of seats is considered.
  - 3.2.3.3. the residual space is determined according to all possible seating arrangements.
  - 3.2.3.4. the maximum distance between the centre lines of the outboard passenger seats.
- 3.2.4. Further detailed documentation, parameters, data depending on the approval test method chosen by the manufacturer, as detailed in Annex 5, Annex 6, Annex 7, Annex 8 and Annex 9.
- 3.2.5. In case of an articulated vehicle, all of this information shall be given separately for the two rigid parts of the vehicle type, except for paragraph 3.2.1.1. which is related to the complete vehicle.
- 3.3. On request of the Technical Service a complete vehicle shall be presented to check its unladen kerb mass, axle loads, position of the centre of gravity and all other data and information which are to the strength of superstructure.
- 3.4. According to the approval test method chosen by the manufacturer, appropriate test pieces, shall be submitted to the Technical Service upon its request. The arrangement and number of these test pieces shall be agreed with the Technical Service. In case of test pieces which have been tested earlier, the test reports shall be submitted.

#### **4. APPROVAL**

- 4.1. If the vehicle submitted for approval to this Regulation meets the requirements of paragraph 5 below, approval of that vehicle type shall be granted
- 4.2. An approval number shall be assigned to each vehicle type approved. Its first two digits (at present 00 for the Regulation in its original form) shall indicate the series of amendments incorporating the most recent major technical amendments made to the Regulation at the time of issue of the approval. The same Contracting Party shall not assign the same number to another vehicle type as defined in paragraph 2.2. above.
- 4.3. Notice of approval or of refusal or extension of approval of a vehicle type pursuant to this Regulation shall be communicated to the 'Parties' to the Agreement which apply this Regulation, by means of a form conforming to the model in annex 1 to this Regulation and of drawings and diagrams supplied by the applicant for approval, in a format not exceeding A4 (210 x 297 mm) or folded to that format and on an appropriate scale.
- 4.4. There shall be affixed, conspicuously and in a readily accessible place specified on the approval form, to every vehicle conforming to a vehicle type approved under this Regulation an international approval mark consisting of :
  - 4.4.1. a circle surrounding the letter "E" followed by the distinguishing number of the country which has granted approval; 1/

- 4.4.2. the number of this Regulation, followed by the letter "R", a dash and the approval number to the right of the circle prescribed in paragraph 4.4.1.
- 4.5. The approval mark shall be clearly legible and be indelible.
- 4.6. The approval mark shall be placed close to or on the vehicle data plate affixed by the manufacturer.
- 4.7. Annex 2 to this Regulation gives an example of the approval mark.

## 5. GENERAL SPECIFICATIONS AND REQUIREMENTS

### 5.1. Requirements

The superstructure of the vehicle shall have the sufficient strength to ensure that the residual space during and after the rollover test on complete vehicle is unharmed. That means:

- 5.1.1 No part of the vehicle which is outside the residual space at the start of the test (e.g. pillars, safety rings, luggage racks) shall intrude into the residual space during the test. Any structural parts, which are originally in the residual space (e.g. vertical handholds, partitions, kitchenettes, toilets) shall be ignored when evaluating the intrusion into the residual space.
- 5.1.2 No part of the residual space shall project outside the contour of the deformed structure. The contour of the deformed structure shall be determined sequentially, between every adjacent window and/or door pillar. Between two deformed pillars the contour shall be a theoretical surface, determined by straight lines, connecting the inside contour points of the pillars which were the same height above the floor level before the rollover test. (see figure 2)

### 5.2. Residual space

The envelope of the vehicle's residual space is defined by creating a vertical transverse plane within the vehicle which has the periphery described in Figures 1(a) and 1(c), and moving this plane through the length of the vehicle (see Figure 1(b)) in the following manner:

- 5.2.1 The  $S_R$  points are located on each seat-back of the outer seats, 500 mm above the floor under the seats, 150 mm from the inside surface of the side wall. These dimensions shall also be applied in the case of rearwards facing and inward facing seats.
- 5.2.2 If the two sides of the vehicle are not symmetrical in respect of floor arrangement and, therefore, the height of the  $S_R$  points, the step between the two floor lines of the residual space shall be taken as the longitudinal vertical centre plane of the vehicle (see Figure 1(c)).
- 5.2.3 The rearmost position of the residual space is a vertical plane 200 mm behind the  $S_R$  point of the rearmost outer seat.  
The foremost position of the residual space is a vertical plane 600 mm in front of the  $S_R$  point of the foremost seat in the vehicle set at its fully forward adjustment.  
If the rearmost and foremost seats on the two sides of the vehicle are not in the same transverse planes, the length of the residual space on each side will be different.
- 5.2.4 The residual space is continuous between its rearmost and foremost plane and is defined by moving the defined vertical transverse plane through the length of the vehicle along straight lines through the  $S_R$  points on both sides of the vehicle. Behind the rearmost and in front of the foremost seat's  $S_R$  point the straight lines are horizontal.

### 5.3. Specification of rollover test on a complete vehicle

The rollover test is a lateral tilting test, see Figure 3, specified as follows:

- 5.3.1. The full scale vehicle is standing stationary and is tilted slowly to its unstable equilibrium position,

- 5.3.2. The rollover test starts in this unstable vehicle position with zero angular velocity and the axis of rotation runs through the wheel-ground contact points. At this moment the vehicle is characterised by the reference energy  $E_R$  (see Figure 3. and paragraph 3.2.1.4.).
- 5.3.3. The vehicle tips over into a ditch, having a horizontal, dry concrete ground surface with a nominal depth of 800 mm.
- 5.3.4. The detailed technical specification of the rollover test on a complete vehicle as an approval test is given in Annex 5

#### 5.4. Specifications of equivalent approval tests

Instead of the rollover test on a complete vehicle, at the discretion of the manufacturer, one of the following equivalent approval test methods can be chosen:

- 5.4.1 Rollover test on body sections which are representative of the complete vehicle, in accordance with the specifications of Annex 6.
- 5.4.2 Computer simulation of the standard rollover test in accordance with the specifications of annex 7.
- 5.4.3. Calculation method based on the results of quasi-static tests in accordance with the specifications of Annex 9
- 5.4.4 The basic principle is that the equivalent approval test method must be carried out in such a way that it represents the rollover test specified in the appendix of annex 5. If the equivalent approval test method chosen by the manufacturer cannot take account of some special feature or construction of the vehicle (e.g. air-conditioning installation on the roof, changing height of the waist rail, changing roof height) the complete vehicle may be required by the Technical Service to undergo the rollover test specified in annex 5.

#### 5.5. Test of articulated buses

In the case of an articulated vehicle, each section of the vehicle shall comply with the general requirement specified in paragraph 5.1. Each section of an articulated vehicle may be tested separately or in combination as described in Annex 5 para 2.3.

#### 5.6. Direction of rollover test

The rollover test shall be carried out on that side of the vehicle which is more dangerous with respect to the residual space. The decision is made by the competent Technical Service on the basis of the manufacturer's proposal, considering at least the following.

- 5.6.1. the lateral eccentricity of the centre of gravity and its effect on the potential energy in the unstable, starting position of the vehicle.
- 5.6.2. the asymmetry of the residual space, see paragraph 5.2.6.
- 5.6.3 the different, asymmetrical constructional features of the two sides of the vehicle; which side is stronger, better supported by partitions or inner boxes (e.g. wardrobe, toilet, kitchenette)

Figure 1

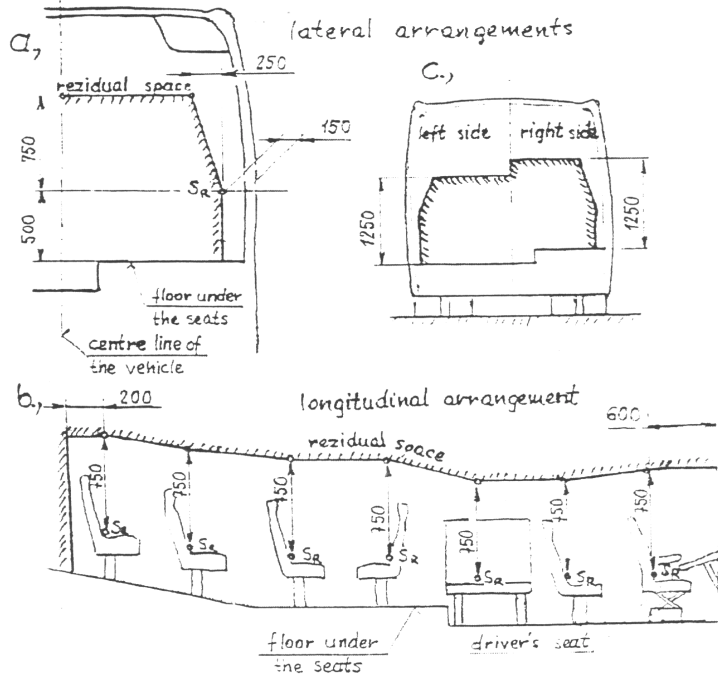

Figure 1 The residual space

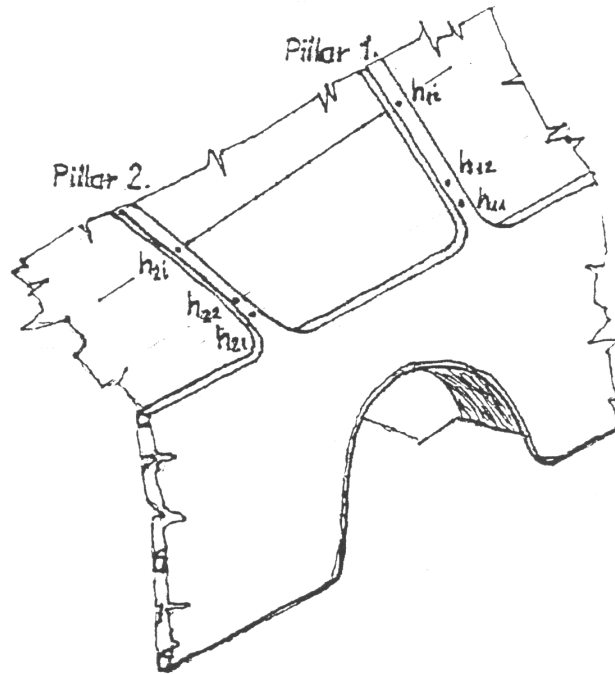

Figure 2 Definition of contour



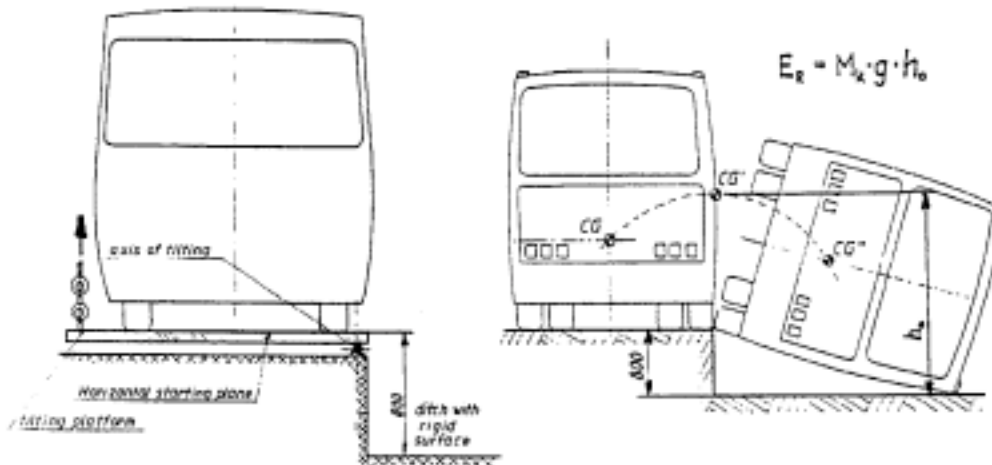

Figure 3 Rollover test with complete vehicle”

## 6. MODIFICATION AND EXTENSION OF APPROVAL OF A VEHICLE TYPE

6.1 Every modification of the vehicle type shall be to the administrative department which granted the type approval. The department may then either,

6.1.1 consider that the modifications made are unlikely to have an appreciable effect and that in any case the vehicle still complies with the requirements; or

6.1.2 require a further test report from the technical service responsible for conducting the tests

6.1.3. The consideration should be based on three aspects:

6.1.3.1. constructional aspect; means whether there is any change in the superstructure (dimensions, material, constructional details, technology, etc.) and if there is, whether it is significant or not, see Annex 4.

6.1.3.2. energy aspect; means whether the reference energy ( $E_R$ ) is changed or not. If the modified vehicle type has the same or smaller reference energy than the approved vehicle, no further test is needed from the energy aspect.

6.1.3.3. residual space aspect; means whether changes in the passenger and driver's compartment (e.g. seat arrangement, etc.) affect the residual space, or not.

6.2 Confirmation or refusal of approval, specifying the alterations, shall be notified by the procedure specified in paragraph 4.3 above to the Parties to the Agreement which apply this Regulation.

6.3 The competent authority issuing the extension of approval shall assign a series number to each communication form drawn up for such an extension.

## 7. CONFORMITY OF PRODUCTION

7.1. Every vehicle bearing an approval mark as prescribed under this Regulation shall conform to the vehicle type approved.

7.2. In order to verify this conformity only the elements of the superstructure shall be considered, see in Annex 4. Only those structural elements which are nominated by the manufacturer as part of the superstructure, shall be checked.

- 7.3. When checking the superstructure, the conformity shall be based on the material, the geometry, and the joint technology, of the elements of the superstructure.  
The checking authority shall,
- 7.3.1 have access to control equipment necessary for checking the conformity to each approved type
  - 7.3.2 ensure that data of test results are recorded and that annexed documents shall remain available for a period to be determined in accordance with the administrative service, and
  - 7.3.3 analyse the results of each type of test, in order to verify and ensure the stability of the product characteristics, making allowance for variation of an industrial production.
- 7.4. The manufacturer shall control continuously the parameters described in para 7.3. and shall ensure that the data of test results are recorded and remain available for a period determined by the Administrative Service.
- 7.5. The Competent Authority which has granted type approval may at any time check and verify the conformity. The normal frequency of inspection is to be determined by the Technical Service, considering the yearly production of the vehicle type, but it shall not be less than once per year.

## **8. PENALTIES FOR NON-CONFORMITY OF PRODUCTION**

- 8.1 The approval granted in respect of a vehicle type pursuant to this Regulation may be withdrawn if the requirements laid down in paragraph 10.1 above are not complied with.
- 8.2 If a party to the Agreement applying this Regulation withdraws an approval it has previously granted, it shall forthwith so notify the other Contracting Parties applying this Regulation, by means of a copy of the approval form bearing at the end, in large letters, the signed and dated annotation "APPROVAL WITHDRAWN"

## **9 PRODUCTION DEFINITELY DISCONTINUED**

If the holder of the approval completely ceases to manufacture a type of vehicle approved in accordance with this Regulation, he shall so inform the authority which granted the approval. Upon receiving the relevant communication, that authority shall inform thereof the other Parties to the Agreement applying this Regulation by means of a copy of the approval form bearing at the end, in large letters, the signed and dated annotation "PRODUCTION DISCONTINUED".

## **10. TRANSITIONAL PROVISIONS - TO BE DRAFTED**

- 11 NAMES AND ADDRESSES OF TECHNICAL SERVICES RESPONSIBLE FOR CONDUCTING APPROVAL TESTS, AND OF ADMINISTRATIVE DEPARTMENTS**
- The Parties to the Agreement which apply this Regulation shall communicate to the United Nations Secretariat the names and addresses of the technical services responsible for conducting approval tests and of the administrative departments which grant approval and to which forms certifying approval or extension or refusal or withdrawal of approval, issued in other countries, are to be sent.

Footnotes - To be formulated according to current UN-ECE WP29/GRSG requirements

**Annex 1**

- 1/ Communication concerning:  
approval  
refusal of approval  
extension of approval  
withdrawal of approval  
production definitely discontinued

2/ of a vehicle type with regard to the strength of its  
superstructure pursuant to Regulation No. 66  
Approval No.            Extension No.

1. Trade name or mark of the Vehicle
2. Vehicle Type
3. Manufacturer's name and address
4. If applicable, name and address of the manufacturer's representative
5. Brief summary of description of the superstructure in respect of paragraph 3.2.2 and annex 4.
6. Exact drawing about the residual space used in the approval procedure
7. The position of the centre of gravity of the unladen vehicle in the longitudinal, transverse and vertical directions
8. Unladen kerb mass (kg)
9. The value of reference energy ( $E_R$ ) according to paragraph 3.2.1.4.
10. Vehicle submitted for approval on
11. Method of test or calculation employed for approval
12. Direction of the rollover test used or supposed during the approval procedure
13. Technical service responsible for conducting approval tests
14. Date of test report issued by that service
15. Number of report issued by that service
16. Approval granted/refused/extended/withdrawn 2/
17. Reason(s) of extension (if applicable)
18. Position of approval mark on the Vehicle

List of documents, containing data specified in para. 3.2. and in the appropriate annex which specifies the used approval test method. The listed documents are deposited by the competent authority and are available on request .....

Place:

Date:

Signature:

**Annex 2 - ARRANGEMENT OF THE APPROVAL MARK**  
(see paragraph 4.4 of this Regulation)

Figure R66s2.gif

The above approval mark affixed to a vehicle shows that the vehicle type concerned has, with regard to the strength of the superstructure, been approved in the United Kingdom (E11) pursuant to Regulation No. 66 under approval number 002431. The first two digits of the approval number indicate that the approval was granted in accordance with the requirements of Regulation No. 66 in its original form.

## **ANNEX 3 DETERMINATION OF THE CENTRE OF GRAVITY OF THE VEHICLE**

### 1 General principles

1.1 The energy levels in the rollover test depend directly on the vehicle's centre of gravity position: Therefore, its determination should be as accurate as possible. The following accuracy is required.

For dimensions less than 2000 mm,	accuracy of	$\pm 1$ mm
For dimensions greater than 2000 mm,	accuracy of	$\pm 0.05$ per cent
For angles,	accuracy of	$\pm 1$ per cent
For load values	accuracy of	$\pm 0.2$ per cent

1.2 Unblocked suspension introduces a number of variables in the calculation of height of centre of gravity which are difficult to determine with any degree of certainty. Therefore, blocked suspension is specified as the condition for determining centre of gravity and for carrying out the actual roll-over test.

1.3 The position of the centre of gravity is defined by three parameters:

1.3.1. longitudinal distance ( $l_f$ ) from the centre line of front axle

1.3.2. transverse distance ( $t$ ) from the centre of pressure of the wheel on the left-hand end of the front axle of the vehicle.

1.3.3. vertical height ( $h$ ) above the horizontal ground level when the tyres are inflated as specified for the vehicle

1.3 A method for determining  $l_f$ ,  $e$ ,  $h$ , using load cells is described here. Alternative methods using lifting equipment and/or tilt tables for example may be proposed by the manufacturer to the Technical Service who will decide whether the method is acceptable based on its degree of accuracy.

### 2. Measurement:

2.1. The longitudinal ( $l_f$ ) and transverse ( $e$ ) co-ordinates of the centre of gravity shall be determined with the vehicle on flat, horizontal ground (see Figure A3.1)

2.2. The height of the centre of gravity ( $h$ ) shall be determined by tilting the vehicle, either longitudinally or transversely, with the suspension blocked. For accuracy, it is recommended that the height of the CG is computed using both methods, and the arithmetic average is taken.

2.3 the vehicle shall be in the unladen kerb mass ( $M_k$ ) condition as defined in para. 2.8 of the main text of this Regulation.

2.4 Calculation of the longitudinal and transverse position of CG in the horizontal plane.

The total weight [ $W$ ] of the vehicle shall be determined by the test station: the vehicle shall be placed with each wheel, or twinned wheel, on a load cell set in a common horizontal plane. Each steered wheel shall be set to its zero straight-ahead steer position. The individual load-cell readings shall be noted simultaneously. The wheel-base(s) and track(s) of the vehicle shall be accurately measured.

The individual load-cell readings are used to calculate the total vehicle weight and the moment of the CG.

2.4.1. The longitudinal position of the CG relative to the centre of the contact point of the front wheels is calculated by simple moments (see Figure A3.1),

$$l_f = \frac{(P_3 + P_4) \cdot L_1 + (P_5 + P_6) \cdot L_2}{M_k} \quad \dots \text{Equ. 1}$$

where

$P_1$  = reaction load on the load cell under the left-hand wheel of the front (1<sup>st</sup> axle) of the vehicle

$P_2$  = reaction load on the load cell under the right-hand wheel of the 1<sup>st</sup> axle of the vehicle

$P_3$  = reaction load on the load cell under the left-hand wheel(s) of the 2<sup>nd</sup> axle of the vehicle

$P_4$  = reaction load on the load cell under the right-hand wheel(s) of the 2<sup>nd</sup> axle of the vehicle  
 $P_5$  = reaction load on the load cell under the left-hand wheel(s) of the 3<sup>rd</sup> axle of the vehicle  
 $P_6$  = reaction load on the load cell under the right-hand wheel(s) of the 3<sup>rd</sup> axle of the vehicle  
 $M_k = (P_1 + P_2 + P_3 + P_4 + P_5 + P_6)$   
 $L_1$  = wheel base of the vehicle, centre of wheel on 1<sup>st</sup> axle to centre of wheel on 2<sup>nd</sup> axle  
 $L_2$  = wheel base of the vehicle, centre of wheel on 1<sup>st</sup> axle to centre of wheel on 3<sup>rd</sup> axle, if fitted  
 $l_1$  = distance along the longitudinal axis of the vehicle from the axis of the front wheel to the transverse line of action of the CG.

2.4.2. The transverse position of the vehicle CG relative to the left front wheel is calculated by simple moments (see Figure A3.2), for example

$$t = \frac{T_1}{2} + \left\{ (P_1 - P_2) \cdot \frac{T_1}{2} + (P_3 - P_4) \cdot \frac{T_2}{2} + (P_5 - P_6) \cdot \frac{T_3}{2} \right\} \cdot \frac{1}{M_k} \quad \dots \text{Equ. 2}$$

where

$T_1$  = distance between the centres of the footprint of the wheel(s) at each end of the 1<sup>st</sup> axle of the vehicle  
 $T_2$  = distance between the centres of the footprint of the wheel(s) at each end of the 2<sup>nd</sup> axle of the vehicle  
 $T_3$  = distance between the centres of the footprint of the wheel(s) at each end of the 3<sup>rd</sup> axle of the vehicle  
 $t$  = distance along the transverse axis of the vehicle from the centre of the contact point of the left-hand front wheel to the centre of action of the vehicle CG.

**Note Well:** This equation assumes that a straight line can be drawn through the centre points of T1, T2, T3. If this is not the case then a specialised formula will be required.

## 2.5 Calculation of the vertical height of the CG

The suspension shall be blocked, to fix the CG of the unsprung masses with respect to the CG of the sprung mass.

### 2.5.1 Calculation based on longitudinal inclination.

2.5.1.1 Two load-cells shall be positioned on a common horizontal plane, to receive the front wheels. The horizontal plane shall be at sufficient height above the surrounding surfaces that the vehicle can be tilted forward to the required angle (see para.2.5.1.2 below) without its nose touching that surface.

2.5.1.2 A second pair of load-cells shall be placed in a common horizontal plane on top of support structures, ready to receive the wheels of the 2<sup>nd</sup> axle of the vehicle. The support structures shall be sufficiently tall to generate a significant angle of slope (> 25 °) to the vehicle. The greater the angle, the more accurate will be the calculation – see Figure A3.3.

The vehicle is repositioned on the four load-cells, with the front wheels chocked to prevent the vehicle rolling forward.

The loads in the load cells shall be noted and the inclination (centre of front wheel disc to centre of rear wheel disc) shall be measured.

The moment of the total vehicle mass around the centre of the contact point of the front wheel is calculated as,

$$L_a = \frac{L_1 \cdot (F_3 + F_4)}{M_k} \quad \dots \text{Equ. 3}$$

where

$F_3$  = reaction load on the load cell under the left-hand wheel(s) of the 2<sup>nd</sup> axle of the vehicle  
 $F_4$  = reaction load on the load cell under the right-hand wheel(s) of the 2<sup>nd</sup> axle of the vehicle  
 $L_1$  = horizontal distance between the centre of the contact point of the left front wheel and the left-hand wheel(s) of the 2<sup>nd</sup> axle of the vehicle  
 $L_a$  = horizontal distance between the centre of the contact point of the left front wheel and the line of action of the CG of the vehicle.

Figure A3.1

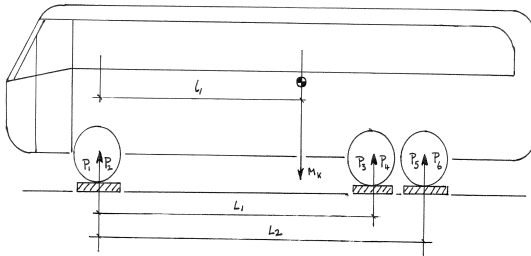

Figure A3.2

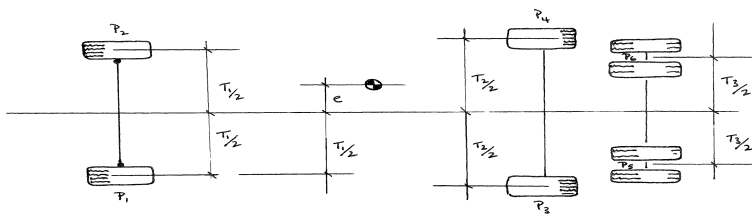
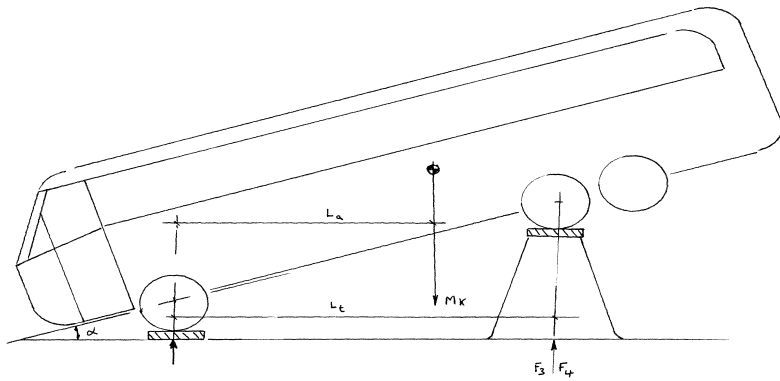

Figure A3.3





## **ANNEX4 VIEW-POINTS TO THE STRUCTURAL DESCRIPTION OF THE SUPERSTRUCTURE**

### **1. General principles**

- 1.1.** The manufacturer shall define unambiguously the superstructure of the body-work (see Figure A4.1, for example) and shall state:
  - 1.1.1. which bays contribute to the strength and energy absorption of the superstructure
  - 1.1.2. which connecting elements between the bays contribute to the torsional stiffness of the superstructure.
  - 1.1.3. the mass distribution among the nominated bays
  - 1.1.4. which elements of the superstructure are assumed as rigid parts
- 1.2.** The manufacturer shall supply the following information about the elements of the superstructure:
  - 1.2.1. drawings, with all the significant geometrical measurements necessary to produce the elements and to evaluate any change or alteration of the element,
  - 1.2.2. the material of the elements referred to national, or international standards
  - 1.2.3. the joint technology between the structural elements (riveted, bolted, glued, welded, type of welding, etc.)
- 1.3.** Every superstructure shall have at least two bays: one in front of the CG and one behind the CG.
- 1.4.** No information is required about any elements of the body-work, which are not parts of the superstructure.
- 1.5.** When a new variant is developed from an approved vehicle type, but no changes are made in the superstructure, its elements and their joints, the body-work of the new variant is assumed to have the same strength as the approved vehicle type.

### **2. Bays**

- 2.1.** A bay is defined as a transverse section of superstructure containing at least one window pillar from each side-wall. Every bay has a transverse centre plane (CP) perpendicular to the longitudinal axis of the vehicle and passing through the centre points ( $C_p$ ) of the window-pillars (see Figure A4.2)
- 2.2.** The  $C_p$  is defined as a point at half window height and halfway across the pillar width. If the  $C_p$  of the left-side and right- side pillars of a bay are not in the same transverse plane, the CP of the bay is set halfway between the transverse planes of the two  $C_p$ -s
- 2.3.** The length of a bay is measured in the direction of the longitudinal axis of the vehicle, and is determined by the distance between two planes perpendicular to the longitudinal axis of the vehicle. There are two limits which define the length of a bay; the window (door) arrangement, and the shape and construction of the window (door) pillars (see Figure A4.2)
  - 2.3.1.** The maximum length of a bay is defined by the length of the two neighbouring window (door) frames (see Figure A4.2)

$$(W_j)_{\max} = 1/2 (a + b) \quad \dots 1$$

where  $a$  = the length of the window (door) frame behind the  $j^{\text{th}}$  pillar, and  
 $b$  = the length of the window (door) frame in front of the  $j^{\text{th}}$  pillar

Note Well: If the pillars on opposite sides of the bay are not in one transverse plane, or the window frames on each side of the vehicle have different lengths, the overall length,  $W_j$  of the bay is defined by,

$$(W_j)_{\max} = 1/2(a_{\min} + b_{\min} - 2M) \quad \dots 2$$

where  $a_{\min}$  = the smaller value of  $a_{\text{right side}}$  or  $a_{\text{left side}}$   
 $b_{\min}$  = the smaller value of  $b_{\text{right side}}$  or  $b_{\text{left side}}$  (see Figure A4.3)

2.3.2 The minimum length of a bay shall include the whole window pillar (including its inclination, corner radii, etc.). If the inclination and corner radii exceed half the length of the adjacent window then the next pillar shall be included in the bay.

2.4 The distance between two bays shall be defined as the distance between their CP-s .

2.5 The distance of a bay from the CG of the vehicle shall be defined as the perpendicular distance from its CP to the vehicle CG

### 3. Connecting structures between the bays.

3.1. The connecting structures between bays shall be clearly defined in the superstructure. These structural elements fall into two distinct categories:

3.1.1. the connecting structures which form part of the superstructure. These elements shall be identified by the manufacturer, in this design submission: they include

3.1.1.1 side-wall structure, roof structure, floor structure, which connect several bays,

3.1.1.2 structural elements which reinforce one or more bays; for example, boxes under seats, wheel arches, seat structures connecting side-wall to floor, kitchen, wardrobe and toilet structures

3.1.2. the additional elements which do not contribute to the structural strength of the vehicle, for example: ventilation ducts, hand luggage boxes, heating ducts. Information about these elements required.

### 4. Mass distribution

4.1. The manufacturer shall clearly define the portion of the unladen mass of the vehicle ( $M_k$ ) attributed to each of the bays of the superstructure. This mass distribution shall express the energy absorbing capability and load bearing capacity of each bay. The following requirements shall be met when distributing the unladen mass:

4.1.1. the sum of the masses attributed to each bay shall be related to the unladen mass:

$$\sum_{j=1}^n (m_j) \geq M_k \quad \dots 3$$

where  $m_j$  = the mass attributed to the  $j^{\text{th}}$  bay  
 $n$  = the number of bays in the superstructure

4.1.2. the CG of the distributed masses shall be in the same position as the CG of the vehicle:

$$\sum_{j=1}^n (m_j l_j) = 0 \quad \dots 4$$

where  $l_j$  = the distance of the  $j^{\text{th}}$  bay from the CG of the vehicle (see para, 2.3.).  
 $l_j$  is positive, if the bay is in front of the CG and negative if it is behind it.

4.2. The mass „ $m_j$ ” of each bay of the superstructure shall be defined by the manufacturer, as follows

4.2.1. the masses of the components of the „ $j^{\text{th}}$ ” bay shall be related to its mass „ $m_j$ ” by:

$$\sum_{k=1}^s m_{jk} \geq m_j \quad \dots 5$$

where  $m_{jk}$  = the mass of each component of the bay  
 $s$  = number of individual masses on the bay

4.2.2. the CG of the component masses of a bay shall have the same transverse position inside the bay as the bay’s CG (see Fig.3.):

$$\sum_{k=1}^s m_{jk} y_k \equiv \sum_{k=1}^s m_{jk} z_k \equiv 0 \quad \dots 6$$

where  $y_k$  = the distance of the  $k^{\text{th}}$  mass component of the bay from the axis „Z” (see Figure A4.4).  $y_k$  will have a positive value on one side of the axis and a negative value on the other side.

$z_k$  = the distance of the  $k^{\text{th}}$  mass component of the bay from the axis “Y”,  $z_k$  will have a positive value on one side of the axis and a negative value on the other side.

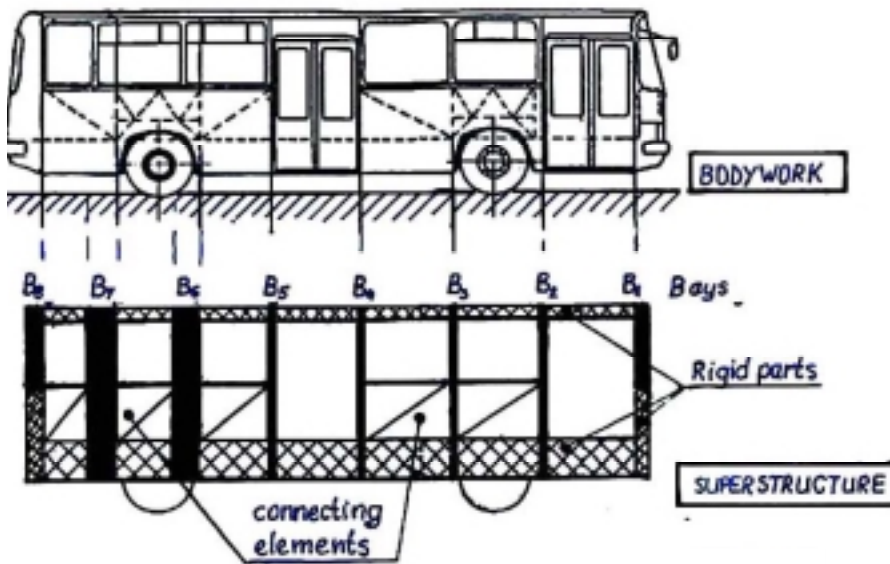

Figure A4.1

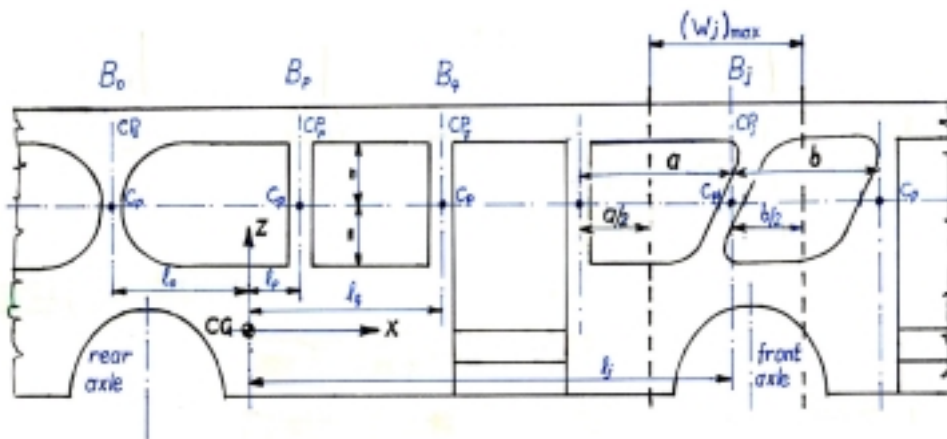

Figure A4.2

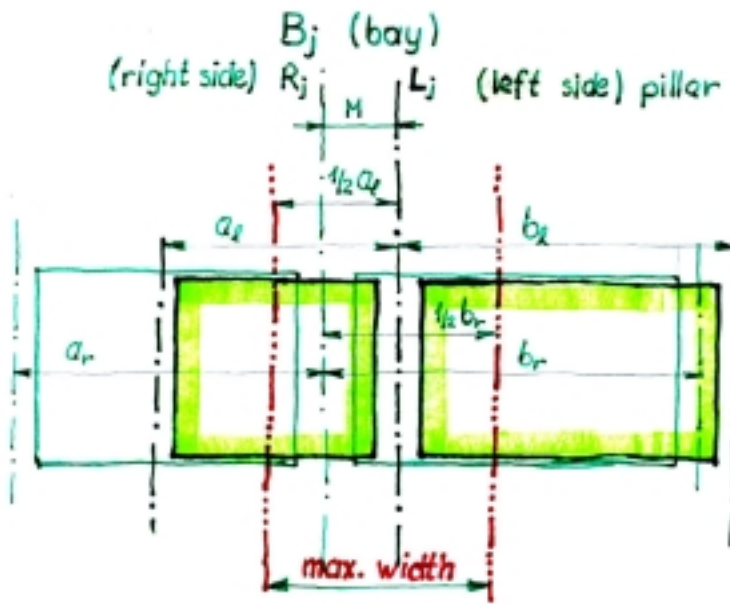

Figure A4.3

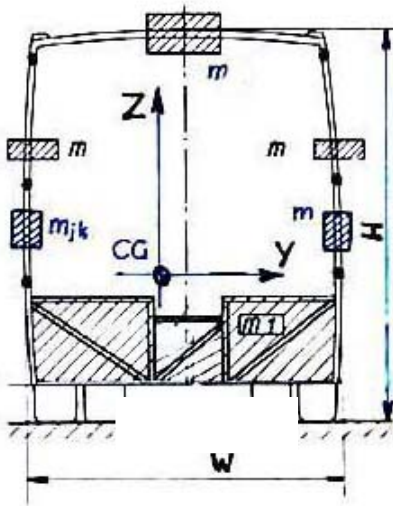

Figure A4.4

## **ANNEX 5 ROLLOVER OF FULL SCALE VEHICLE AS THE BASIC APPROVAL TEST METHOD**

### **1 The tilting test bench**

- 1.1 The tilting platform shall be rigid enough and rotated so that the simultaneous lifting of the axles of the vehicle shall be ensured. No bigger difference than 1° is allowed between the tilting angle of the platform below each axle.
  
- 1.2 The height difference between the horizontal lower plane of the ditch (see Figure.A5.1) and the plane of the tilting platform on which the bus is standing, shall be 800±20 mm
  
- 1.3 The tilting platform, related to the ditch, shall be placed as follows (see Figure A5.1) :
  - 1.3.1 the axis of its rotation is max 100 mm from the vertical wall of the ditch
  - 1.3.2 the axis of the rotation is max 100 mm below the plane of the horizontal tilting platform
  
- 1.4 Wheel supports shall be applied at the wheels being close to the axis of rotation against sliding of the vehicle sideways when tilting it.
  - 1.4 The main considerations of wheel supports shall be (see figure A5.1)
    - 1.4.1 dimensions of one wheel support:

Height	80 mm
Width	20 mm
Edge radius	10 mm
Length	min. 500 mm
  
    - 1.4.2 the wheel supports at the widest axle shall be placed on the tilting platform so that the side of the tyre from the axis of rotation is 20 mm
    - 1.4.3 the wheel supports at the further axles shall be adjusted so that the longitudinal axis of the vehicle shall be parallel to the axis of rotation.
  
- 1.5 Means shall be provided on the tilting platform to prevent the vehicle moving along its longitudinal axis.
  
- 1.6 The impact area of the ditch shall have a horizontal, uniform concrete surface.

### **2. Preparation of tested vehicle**

- 2.1 The vehicle to be tested need not be in a fully finished, “ready for operation” condition. Generally: any alteration from the fully finished condition is acceptable if the basic feature and behaviour of the superstructure is not influenced by it. The test vehicle shall be the same as its fully finished version in respect of the followings:
  - 2.1.1 the position of the CG, the value of unladen kerb mass and the distribution and location of masses as declared by the manufacturer
  
  - 2.1.2 all of those elements which - at the manufacturer’s discretion - contribute to the strength of the superstructure shall be installed in their original position ( see Annex 4 to this Regulation)
  - 2.1.3 elements, which do not contribute to the strength of the superstructure and they have too great value for damage (e.g. drive chain, dashboard instrumentation, driver’s seat, kitchen equipment, toilet equipment, etc.) can be replaced by additional elements being equivalent in mass and the way of installation. This additional elements must not have reinforcing effect on the strength of superstructure
  - 2.1.4 fuel, battery acid and other combustible, explosive or corrosive materials may be substituted by other materials provided that the conditions of para 2.1.1. are met.\*\*\*\*\*
  
- 2.2 The test vehicle shall be prepared as follows:

- 2.2.1 tyres shall be inflated to the pressure prescribed by the manufacturer.
  - 2.2.2 all axles of the vehicle, the spring and suspension system shall be fixed. The floor of the vehicle shall be horizontal on the horizontal tilting platform, the floor height shall be according to the manufacturer specification for unladen vehicle.
  - 2.2.3 every door and opening window of the vehicle shall be closed but not locked.
- 2.3 The rigid sections of an articulated vehicle may be tested separately or in combination.
- 2.3.1 For testing the articulated sections as a combination, the sections of the vehicle shall be fixed to each other in such a way that,
    - 2.3.1.1 there is no relative movement between them during the roll-over process.
    - 2.3.1.2 there is no significant change in mass distribution and CG positions
    - 2.3.1.3 there is no significant change in the strength and deformation capability of the superstructure.
  - 2.3.2, For testing the articulated sections separately, the single-axle sections shall be attached to an artificial support which keeps them in fixed relation to the tilting platform during its movement from the horizontal to the point of roll-over. This support shall meet the following requirements:
    - 2.3.2.1 it shall be fixed to the structure in such a way that it does not cause either reinforcement or extra additional load to the superstructure.
    - 2.3.2.2 it shall be constructed so that it does not suffer any deformation which could change the direction of the rollover of the vehicle.
    - 2.3.2.3 its mass shall be equal to the mass of those elements, parts of the articulated joint, which nominally belong to the section being tested, but which are not placed on it (e.g. turntable and its floor, handholds, rubber sealing curtains, etc.).
    - 2.3.2.4 its CG shall have the same height as the common CG of those parts which are mentioned in para 2.3.3.
    - 2.3.2.5 it shall have an axis of rotation parallel to the longitudinal axis of the multi-axle section of the vehicle, and passing through the points of contact of the tyres of that section.

### 3. Test procedure, test process

- 3.1 The rollover test is a very rapid, dynamic process having distinguishable stages, which are described in the attached Appendix 1. These should be taken into consideration when a rollover test, its instrumentation and measurement are planned.
- 3.2 The vehicle shall be tilted without rocking and without dynamic effects until its rolls over. The angular velocity shall not exceed 5 degrees per second (0,087 radians/sec)
- 3.3. For inside observation high-speed photography, video, deformable templates, electrical contact sensors or other suitable means shall be used to determine that the requirements of para 5.1 in the main text of this Regulation has been met. This shall be verified at any places of the passenger compartment where the residual space seems to be endangered, the exact positions being at the direction of the technical service. At least two positions, nominally at the front and rear of the passenger compartment shall be used.
- 3.4. Outside observation and recording of the rollover and deformation process is recommended, which means the followings:
  - 3.4.1. two high-speed cameras - one at the front and another at the rear. They should be located far enough from the front and rear wall of the vehicle to produce a measurable picture, by avoiding wide-angle distortion, in the shaded area shown in Figure A5.2a
  - 3.4.2. the position of the CG and the contour of the superstructure (see Figure A5.2b), is marked by stripes and bands to ensure correct measurements on the pictures.

#### 4. Documentation of the rollover test

- 4.1. Detailed description of the tested vehicle shall be given by the manufacturer in which:
  - 4.1.1. all the deviations between the fully finished, ready-for-operation vehicle type and the tested vehicle are listed.
  - 4.1.2. the equivalent substitution (in respect of mass, mass distribution and installation) shall be proved in every case, when structural parts, units are substituted by other units or masses.
  - 4.1.3. there is a clear statement of the position of CG in the tested vehicle which may be based on measurements carried out on the test vehicle when it is ready for test, or a combination of measurement (carried out on the fully finished vehicle type) and calculation based on the mass substitutions.
- 4.2. The test report shall contain all the data (pictures, records, drawings, measured values, etc.) which show:
  - 4.2.1. that test was carried out according to this Annex
  - 4.2.2. that the requirements given in para 5.1.1. and 5.1.2. in the main text of this Regulation are met (or not)
  - 4.2.3. the individual evaluation of inside observations
  - 4.2.4. all the data and information needed for the identification of the vehicle type, the test vehicle, the test itself, and the personnel responsible for the test and its evaluation.
- 4.3. It is recommended to document in the test report the CG's highest and lowest position related to the ground level of the ditch.

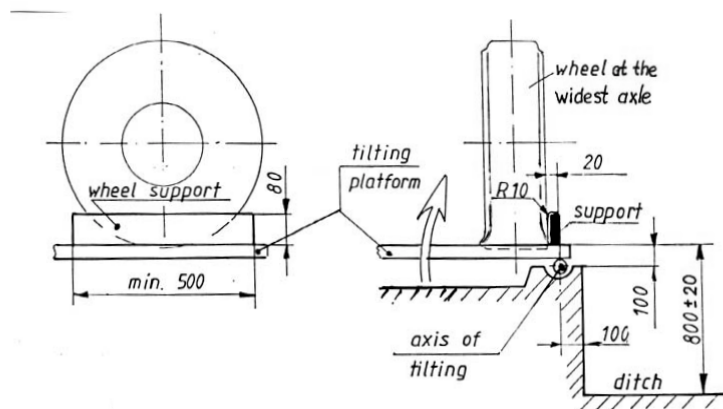

Figure A5.1

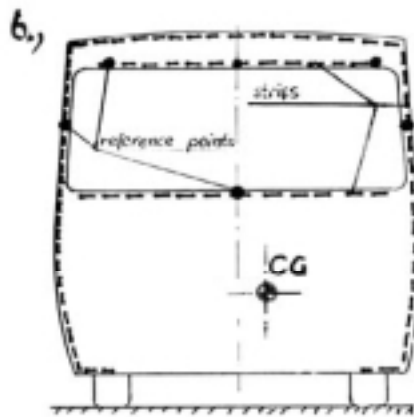
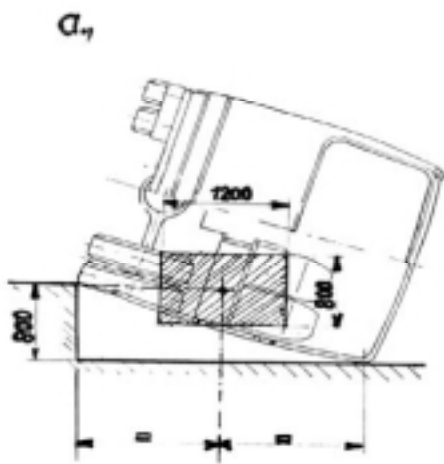

Figure A5.2a  
Figure A5.2b



## ANNEX 5 APPENDIX 1 - THE ROLLOVER TEST AS A TIME-DEPENDENT DYNAMIC PROCESS

1. The rollover test as a time process can be described by different stages belonging to certain moments or time ranges. In every stage at least the following characteristics shall be considered:
  - the motion of the vehicle, as a rigid body or rigid parts of the deformable superstructure (kinematics)
  - the acting and reacting (supporting) dynamic forces on the vehicle (kinetics)
  - the energy balance, considering all kinds of energies and mechanical works belonging to the process
  - deformation process related to the operation of plastic zones and plastic hinges
2. The following main stages of the rollover process may be determined and distinguished
  - a) **Starting position** ( $t=0$ ) Unstable situation, the vehicle is standing on its one-side wheels, no motion. The CG is in the highest position which represents a certain potential energy. (see Figure A5.A1.1a)
  - b) **Rigid body-like rotation** ( $0 < t < t_1$ ) Rollover around the longitudinal axis ( $O_1$ ) determined by the wheel supporting points. The lower and upper part of the vehicle is moving together. The force of gravitation generates increasing angular velocity, the height of CG is decreasing, the potential energy is transformed into kinetic energy.
  - c) **Cantrail collision with the ground** ( $t_1$ ) The vehicle hits the ground, new dynamic supporting (reaction) force is built up alongside the cantrail ( $O_2$ ) where local deformation occurs, and the ground also absorbs certain energy. The motion of the roof (upper part of the vehicle) is slowed down. (see Fig.A5.A1.1c)
  - d) **Main structural deformation** ( $t_1 < t < t_2$ ) There is no more rigid body like motion. The lower and upper part of the vehicle behaves differently. The plastic zones and hinges are working, producing large scale plastic deformation and distortion of the upper part. The lower part continues the rotation around the axis ( $O_1$ ) The CG's height is decreasing which creates further kinetic energy. Supporting forces are acting at ( $O_1$ ) and ( $O_2$ ). The cantrail slides on the ground which absorbs a certain amount of kinetic energy as friction work.
  - e) **Waist-rail collision with the ground** ( $t_2$ ) If the superstructure is not so strong that the structural deformation stops in the previous stage, the waist-rail also hits the ground, where some local deformations may occur. The upper part of vehicle is almost stopped in motion. New dynamic supporting force is created at the waist-rail ( $O_3$ ) while the supporting force at ( $O_1$ ) is decreasing to zero. (see Figure A5.A1.1e)
  - f) **Additional structural deformation** ( $t_2 < t < t_3$ ) The plastic hinges work further, the deformation of the upper part of the superstructure is continuing. The lower rigid part of the vehicle continues the rotation, but around a new axis ( $O_3$ ) and the CG can go upwards. Dynamic mass forces are acting having horizontal components which can cause the sliding of the vehicle on the ground, friction work absorbs energy.
  - g) **Critical structural deformation** ( $t_3$ ) The mass and reaction forces can not overcome the resistance of plastic hinges anymore, the plastic hinges stop to work. This is the moment of the critical (maximum) deformation containing both elastic and plastic deformations. This is the moment in which the requirement of the unharmed residual space shall be checked and proved. This is also an unstable position of the vehicle in respect of its motion. (see Fig.A5.A1.1g)
  - h) **End of the structural deformation** ( $t_4$ ) The elastic deformations spring back, only the permanent deformations remain in the structure. The structural deformation, the danger of the residual space is smaller in the moment  $t_4$  than in  $t_3$ .
  - i) **Further motion of the vehicle** ( $t_4 < t < t_5$ ) The motion of the vehicle in this phase is rigid-body-like again. This is a swinging rotation around the axis ( $O_3$ ) until the final stable position of the vehicle. The kinetic energy is absorbed by friction work, local deformations and by other energy dissipation. This phase of the rollover process is not significant from the point of view of approval, but it has a great importance in the energy balance of the rollover process.
  - j) **End position** ( $t_5$ ) Stable position. The whole vehicle with the deformed superstructure - and its all parts and components - rests upon the ground of the ditch, no more motion, the CG of

the vehicle is in its lowest position.

3. The energy balance of the rollover process is shown on Fig. A5.A1.2. This is also a time dependent process, and studying it at least the following components shall be considered:
- potential energy ( $E_p$ ) determined by the mass and CG's height of the vehicle as a rigid body or rigid parts of the deformable superstructure,
  - kinetic energy ( $E_k$ ) determined by the mass and (angular) velocity of the vehicle as a rigid body or rigid parts of the deformable superstructure,
  - the total energy absorbed by the superstructure ( $E_T$ ) as a result of the operation of plastic zones and plastic hinges, including plastic and elastic deformations,
  - energy absorbed by local deformations ( $W_l$ ) due to the small local deformations, fractures in the structures, which does not influence the main deformation and distortion of the superstructure, does not endanger the residual space,
  - friction work ( $W_s$ ) due to the slips of the vehicle on the ground surface of the ditch in different stages of the process,
  - energy absorbed by the ground ( $W_g$ ) deformation and oscillation when the vehicle hits, contacts the horizontal surface of the ditch,
  - energy dissipation ( $W_0$ ) by sound, by oscillation of the parts, components of the vehicle, etc.

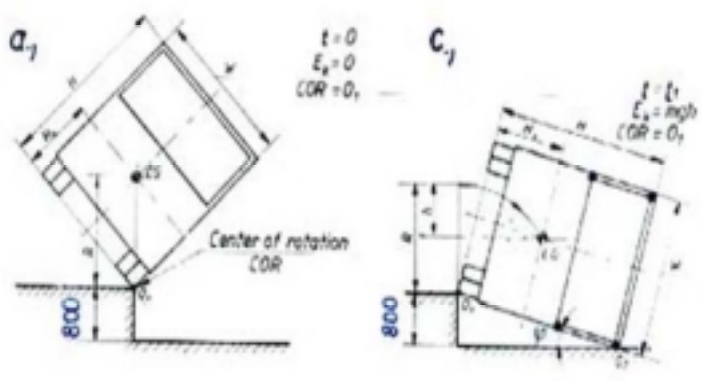

FigureA5.A1.1a  
FigureA5.A1.1c

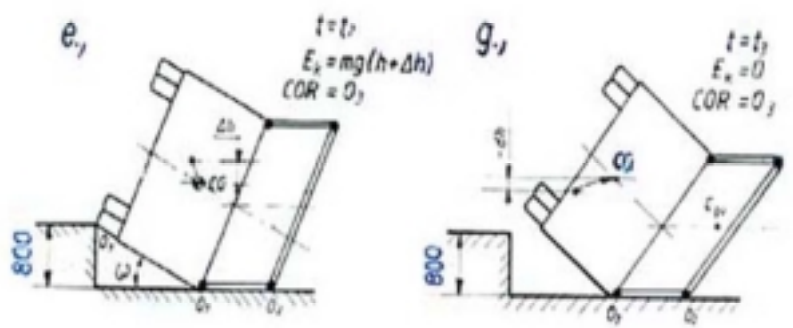

FigureA5.A1.1e  
FigureA5.A1.1g

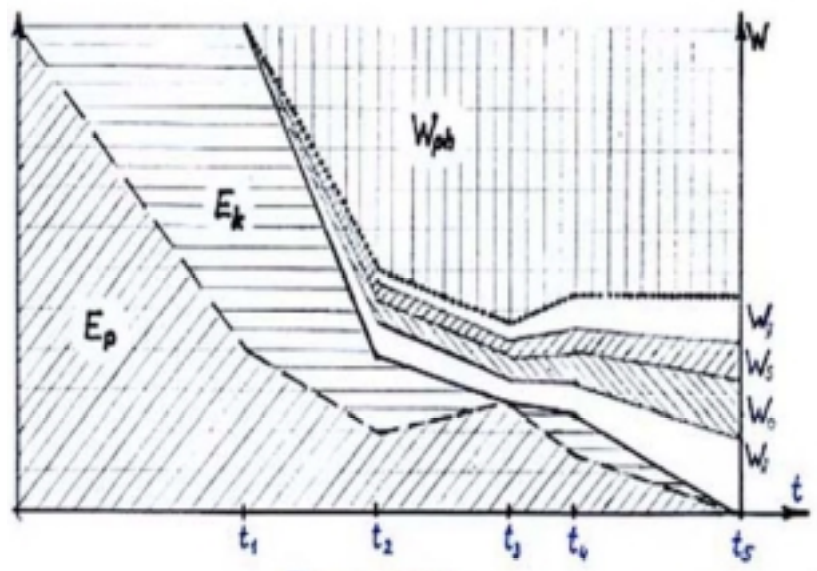

Figure A5.A1.2

## **ANNEX 6 ROLLOVER TEST WITH BODY SECTIONS**

### **1. Additional data and information**

If the manufacturer chooses this method of testing, the following additional information shall be given to the Technical Service in addition to: beyond the data, information and drawings listed in para.3. of the main text of this Regulation,

- 1.1. Drawings of the body sections to be tested
- 1.2. Verification of the validity of Equations 3, 4, 5 and 6, given in Annex 4 para. 4 .1, upon successful completion of the body section rollover tests
- 1.3. The measured masses of the body sections to be tested, and verification that their CG positions are the same as that of the unladen vehicle. (Presentation of measuring reports)

### **2. The tilting bench**

The tilting bench shall meet the requirements given in Annex 5, para. 1.

### **3. Preparation of body sections**

- 3.1. The number of the body sections to be tested shall be determined by the following rules:
  - 3.1.1 all the different bay configurations which are part of the superstructure shall be tested in at least one body section
  - 3.1.2 every body section shall have at least two bays.
  - 3.1.3 in an artificial body section the ratio of the mass of any one bay to any other bay shall not exceed 2.
  - 3.1.4. the residual space of the whole vehicle shall be well represented in the body sections, including any peculiar combinations arising from the vehicles bodywork configuration.
  - 3.1.5 the whole roof structure shall be well represented in the body sections if there are local specialities, like changing height, air condition installation, gas tanks, luggage carrier, etc.
- 3.2. The bays of the body section shall be exactly the same structurally as they are represented in the superstructure, as regards shape, geometry, material, joints
- 3.3. The connecting structures between the bays shall represent the manufacturer's description of the superstructure (see Annex 4 para.3.) and the following rules shall be considered:
  - 3.3.1 in the case of a body section taken directly from the actual vehicle layout, the basic and the additional connecting structures (see para. 3.1. in Annex 4 ) shall be the same as that of the vehicle superstructure
  - 3.3.2 in the case of an artificial body section, the connecting structures shall be equivalent in terms of strength, stiffness and behaviour to that of the vehicle superstructure.
  - 3.3.3 those rigid elements which are not part of the superstructure but which can encroach on the residual space during deformation, shall be installed into the body sections.
  - 3.3.5 the mass of the connecting structures shall be included in the mass distribution, in terms of attribution to a particular bay and distribution within that bay.
- 3.4. The body sections shall be equipped with artificial supports, to provide the same CG positions and axis of rotation for them on the tilting platform as that of the complete vehicle. The supports shall meet the following requirements:
  - 3.4.1 they shall be fixed to the body section in such a way that they do not provide either reinforcement or extra additional load on the body section
  - 3.4.2 they shall be sufficiently strong and rigid to resist any deformation which could change the direction of the body section motion during the tilting and rollover process
  - 3.4.3 their mass shall be included in the mass distribution and CG position of the body section

**3.5.** The distribution of mass in the body section shall be arranged with the following considerations:

- 3.5.1. the whole body section (bays, connecting structures, additional structural elements, supports) shall be considered when checking the validity of Equations 5 and 6, in Annex 4 para. 4.2.
- 3.5.2. any masses attached to the bays (see para 4.2.2. and Fig.4. in Annex 4) shall be placed and fixed to the body section in such a way that they do not cause reinforcement or additional load or limitation of the deformation.

**4. Test procedure.**

The test procedure shall be the same as described in para.3. of Annex 5 for a complete vehicle.

**5. Evaluation of the tests.**

- 5.1. The vehicle type shall be approved if all the body sections pass the rollover test and the Equations 2 and 3 in para. 4 of Annex 4, are fulfilled.
- 5.2. If one of the body sections fails the test, the vehicle type shall not be approved.
- 5.3. If a body section passes the rollover test, each of the bays which form that body section are considered to have passed the rollover test, and the result can be quoted used in future applications for approval, provided that the ratio of their masses remains the same in the subsequent superstructure .
- 5.4. If a body section fails the rollover test, all the bays within that body section shall be considered to have failed the test even if the residual space is invaded in only one of the rings.

**6. Documentation of body section rollover tests**

The test report shall contain all the data necessary to demonstrate,

- 6.1. that the tests were carried out according to this Annex
- 6.2. whether, or not, the requirements - given in para 5.1 of the main text of this Regulation - are met
- 6.3. the individual evaluation of the body sections and their bays.
- 6.4. the identity of the vehicle type, its superstructure, the tested body sections, the tests themselves and the personnel responsible for the tests and their evaluation.

## **ANNEX 7 QUASI- STATIC LOADING TEST OF BODY SECTIONS**

### **1. Additional data and information**

This method of testing uses structural test units, each one built up from at least two bays of the vehicle under appraisal, connected together with representative structural elements. In place of a roll-over test, loads are applied to the static structure.

If the manufacturer chooses this method of testing the following additional information shall be supplied to the Technical Service, in addition to the data, and drawings listed in para.3.2 of the main text of this Regulation:

- 1.1. Drawings of the body sections to be tested.
- 1.2. Energy values to be absorbed by the individual bays of the superstructure, as well as the energy values belonging to the body sections to be tested.
- 1.3. Verification of the energy requirement, see para. 4.2 below, upon completion of successful quasi-static loading tests of body sections.

### **2. Preparation of body sections.**

- 2.1. The manufacturer shall consider the requirements given in Annex 6 paragraphs 3.1, 3.2, and 3.3., when designing and producing the body section for test,
- 2.2. The body section shall be equipped with the residual space profile, at positions where it is considered that the pillars or other structural elements are likely to intrude as a result of the expected deformation.

### **3. Test procedure**

- 3.1. The body section to be tested shall be firmly and securely attached to the test bench through a rigid underframe structure in such a way that
  - 3.1.1. local plastic deformation shall not occur around the attachment points
  - 3.1.2. the location and method of attachment shall not inhibit the formation and working of expected plastic zones and hinges.
- 3.2. For application of the load to the body section, the following rules shall be considered:
  - 3.2.1. the load shall be evenly distributed on the cantrail, through a rigid beam, which is longer than the cantrail to simulate the ground in rollover test, and shall follow this geometry of the cantrail.
  - 3.2.2. the direction of the applied load (see Figure A7.1.) shall be related to the vertical centre plane (VCP) of the vehicle and its inclination ( $\alpha$ ) shall be determined as follows:

$$\alpha = 90^\circ - \arcsin\left(\frac{800}{H_c}\right) \quad \dots 1$$

where  $H_c$  [mm] is the cantrail height of the vehicle measured from the ground when it is standing on a horizontal plane.

- 3.2.3. the load shall be applied to the beam at the CG of the body section derived from the masses of its bays and the structural elements connecting them.. Using the symbols of Fig.A.7.1. the position of the CG can be determined by the following formula:

$$l_{CG} = \frac{\sum_{i=1}^s m_i l_i}{\sum_{i=1}^s m_i} \quad \dots 2$$

where  $s$  is the number of the bays in the body section  
 $m_i$  is the mass of the  $i^{\text{th}}$  bay  
 $l_i$  is the distance of the CG of the  $i^{\text{th}}$  bay from a selected pivot

point.

$l_{CG}$  is the distance of the CG of the body section from the same selected pivot point

3.2.4. the load shall be increased gradually, taking measurements of the associated deformation at discrete intervals until the ultimate deformation „ $d_u$ ” when the residual space is invaded by one of the elements of the body section.

3.3. When plotting the load-deflection curve:

3.3.1. the frequency of measurement shall be such as to produce a continuous curve (see Figure A.7.2.)

3.3.2. the values of load and deformation shall be measured simultaneously

3.3.3. the deformation of the loaded cantrail shall be measured in the direction of the applied load

3.3.4. both load and deformation shall be measured to an accuracy of [ $\pm 1\%$ ]

#### 4. Evaluation of test results

4.1. From the plotted load-deflection curve the actual energy absorbed by the body section ( $E_{BS}$ ) shall be expressed as the area below the curve (see Figure A.7.2.)

4.2. The minimum energy required to be absorbed by the body section ( $E_{min}$ ) shall be determined as follows:

4.2.1. the total energy  $E_T$  to be absorbed by the superstructure is:

$$E_T = 0,75 M_k g \Delta h \quad \dots 3$$

where  $M_k$  is the (unladen) mass of the complete vehicle

$g$  is the gravitational constant and

$\Delta h$  is the distance which the CG of the vehicle falls during a rollover test, as determined in Appendix 1 to this Annex.

4.2.2. the total energy „ $E_T$ ” shall be distributed among the bays of the superstructure in the proportions of their masses:

$$E_j = E_T \frac{m_j}{M_k} \quad \dots 4$$

where  $E_j$  = the absorbed energy by the „ $j^{th}$ ” bay

$m_j$  = mass of the „ $j^{th}$ ” bay, as determined in Annex 4 para.4.1

4.2.3. the minimum energy required to be absorbed by the body section ( $E_{min}$ ) is the sum of the energy of the bays comprising the body section:

$$E_{min} = \sum_{j=1}^S E_j \quad \dots 5$$

4.3. The body section passes the loading test , if:

$$E_{BS} > E_{min} \quad \dots 6$$

In this case, all the bays which form that body section are considered to have passed the quasi-static loading test and these results can be quoted in future requests for approval provided that the component bays are not expected to carry a greater mass in the subsequent superstructure.

4.4. The body section fails the loading test if:

$$E_{BS} < E_{min} \quad \dots 7$$

In this case all the bays which form that body section are considered to have failed the test even if the residual space is invaded in only one of the bays.

4.5. The vehicle type shall be approved if all the required body sections pass the loading test.

**5. Documentation of body section quasi-static loading tests**

The test report shall follow the format of Annex 6 para.6.

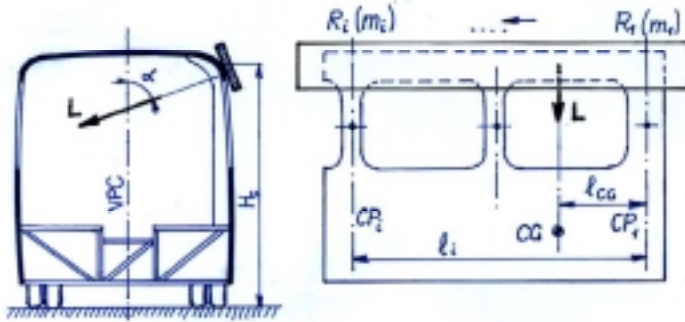

Figure A7.1

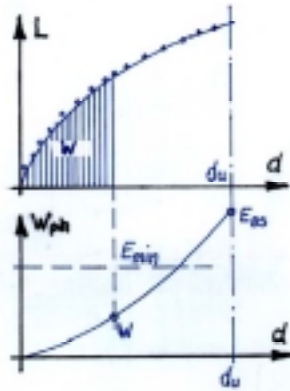

Figure A7.2



## ANNEX 7 APPENDIX 1

### DETERMINATION OF THE VERTICAL MOVEMENT OF CG DURING ROLLOVER - FOR QUASI-STATIC LOADING TEST

The vertical movement ( $\Delta h$ ) of CG related to the rollover test may be determined by the graphical method shown below.

1. Using scaled drawings of the cross-section of the vehicle, the starting position ( position 1 ) of the CG relative to the pivot axis of the tilt table is determined for the vehicle standing at its point of balance on the tilting platform (see Figure A7.A1.1)
2. From the result of the quasi-static load test, the final deformed shape of the body cross-section containing the vehicle CG, shall be drawn to the same scale as in para.1.
3. Using the assumption that the cross-section rotates around the edge of the wheel supports, the deformed vehicle cross-section is drawn with its cant-rail touching the bottom of the ditch (see Figure A7.A1.2). In this position the height of the CG (position 2) relative to the pivot point of the tilt table is determined.
4. The vertical movement of the CG ( $\Delta h$ ) is represented by the height difference between position 1 and position 2 of the CG.
5. If more than one body section is tested and each body section has a different final deformed shape, the vertical movement of CG ( $\Delta h_i$ ) shall be determined for each body section and the combined mean value ( $\Delta h$ ) is taken as,

$$\Delta h = \frac{1}{k} \sum_{i=1}^k \Delta h_i$$

where ( $\Delta h_i$ ) is the vertical movement of the CG of the  $i^{\text{th}}$  body section,  
 $k$  is the number of body sections tested.

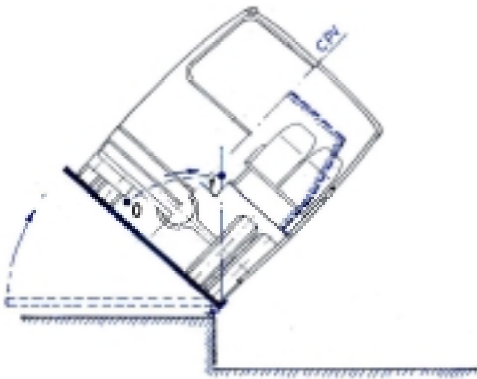

Figure A7.A1.1

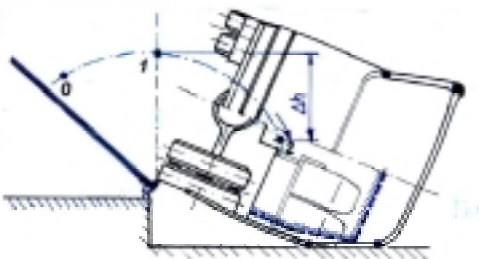

Figure A7.A1.2

**ANNEX 8 - CALCULATION METHOD BASED ON QUASI/STATIC TESTS**

*(The ad hoc Expert Group is discussing whether this subject should be covered in Annex7, and Annex9)*

**ANNEX 9 COMPUTER SIMULATION OF ROLLOVER TEST ON COMPLETE VEHICLE**

*(This annex is still under discussion by the ad hoc Expert Group.)*