



**Economic and Social
Council**

Distr.
GENERAL

ECE/TRANS/WP.29/GRSP/2006/14
12 September 2006

Original: ENGLISH
ENGLISH AND FRENCH ONLY

ECONOMIC COMMISSION FOR EUROPE

INLAND TRANSPORT COMMITTEE

World Forum for Harmonization of Vehicle Regulations

Working Party on Passive Safety

Fortieth session
Geneva, 12-15 December 2006
Item A.2. of the provisional agenda

DRAFT GLOBAL TECHNICAL REGULATION ON HEAD RESTRAINTS

Submitted by the expert from the United States of America

Note: The text reproduced below was prepared by the expert from the United States of America on behalf of the GRSP informal working group on head restraints. The text in square brackets is not yet agreed and is still under consideration by the informal working group.

Note: This document is distributed to the Experts on Brakes and Running Gear only

GE.06-

A. STATEMENT OF TECHNICAL RATIONALE AND JUSTIFICATION

[Reserved for the preamble]

B. DRAFT GLOBAL TECHNICAL REGULATION (GTR) ON HEAD RESTRAINT

TEXT OF REGULATION

1. Scope and Purpose

This gtr specifies requirements for head restraints to reduce the frequency and severity of injuries caused by rearward displacement of the head.

2. Application

This standard applies to all category 1-1 vehicles; category 1-2 vehicles with a gross vehicle mass (GVM) of up to 3,500 kg; and category 2 vehicles, with a gross vehicle mass of up to [3,500 kg].

3. Definitions

3.1 "Adjustable head restraint" means a head restraint that is capable of movement independent of the seatback between at least two positions of adjustment intended for occupant use.

3.2 "Backlight" means rearward-facing window glazing located at the rear of the roof panel.

3.3 "Backset" means the minimum horizontal distance between the front surface of the head restraint and the rear surface of the head restraint measurement device, as measured in accordance with Annex 3.

3.4 ["Designated seating position" – defined in domestic regulations and explained in the preamble.]

3.5 "Head restraint" means, at any designated seating position, a device that limits rearward displacement of a seated occupant's head relative to the occupant's torso that has a height equal to or greater than 700 mm at any point between two vertical longitudinal planes passing at 85 mm on either side of the torso reference line, in any position of backset and height adjustment, as measured in accordance with Annex 1.

3.6 "Head restraint measurement device (HRMD)" means the H-point machine with the head form, as defined in Annex 10, attached with sliding scale at the back of the head for the purpose of measuring backset. ^{1/}

3.7 "Three-dimensional H-point machine" (H-point machine) means the device used for the determination of "H-points" and actual torso angles. This device is defined in Annex 10.

^{1/} The head form is designed by and available from the ICBC, 151 West Esplanade, North Vancouver, BC V7M 3H9, Canada (www.icbc.com).

- 3.8. "Head restraint height" means the distance from the [H-point] [R-point], measured parallel to the torso reference line to the top of the head restraint on a plane normal to the torso reference line.
- 3.9. "Intended for occupant use" means, when used in reference to the adjustment of a seat and head restraint, adjustment positions used by seated occupants while the vehicle is in motion, and not those intended solely for the purpose of allowing ease of ingress and egress of occupants; access to cargo storage areas; and storage of cargo in the vehicle.
- 3.10. "H-point" means the pivot centre of the torso and thigh of the H-point machine when installed in a vehicle seat in accordance with Annex 10. Once determined in accordance with the procedure described in Annex 10, the "H" point is considered fixed in relation to the seat-cushion structure and is considered to move with it when the seat is adjusted.
- 3.11. "R-point" means a design point defined by the vehicle manufacturer for each designated seating position and established with respect to the three-dimensional reference system.
- 3.12. "Top of the head restraint" means the point on the head restraint centerline with the greatest height.
4. General requirements
 - 4.1. Whenever a range of measurements is specified, the head restraint must meet the requirement at any position of adjustment as intended for occupant use.
 - 4.2. In each vehicle subject to the requirements of this regulation, a head restraint that conforms to either paragraphs 5.1. and 5.2., or 5.3. and [5.1.1. through] 5.1.6. of this regulation must be provided at each front outboard designated seating position.
 - 4.3. For vehicles equipped with rear outboard and/or front center head restraints, the head restraint must conform to either paragraphs 5.1. and 5.2. or 5.3. and [5.1.1. through] 5.1.6. of this regulation.
 - 4.4. This regulation does not apply to auxiliary seats such as temporary or folding jump seats.
 - 4.5. At designated seating positions incapable of seating a 50th percentile male Hybrid III test dummy, the applicable head restraint must conform to paragraphs 5.1 and 5.2 of this regulation.
 - [4.6. During or after testing in accordance with this regulation, no sharp or unpadded components of the head restraint structure shall protrude from the front surface of the head restraint.]

5. Performance requirements

- 5.1. Dimensional requirements. Each front outboard head restraint must conform to paragraphs 5.1.1., and 5.1.6. through 5.1.9. of this regulation; each front center head restraint must conform to paragraphs 5.1.2, 5.1.6., 5.1.8. and 5.1.9. of this regulation; each rear outboard head restraint must conform to paragraphs 5.1.4., 5.1.6., 5.1.8. and 5.1.9. of this regulation; each rear center head restraint must conform to paragraphs 5.1.6., 5.1.8. and 5.1.9. of this regulation:
- 5.1.1. Front outboard designated seating positions. When measured in accordance with Annex 1, the top of a head restraint located in a front outboard designated seating position must have a height of: (a) not less than [800 mm] in at least one position of head restraint adjustment; and (b) not less than 750 mm in any position of head restraint adjustment. See exception in paragraph 5.1.3 of this regulation.
- 5.1.2. Front center designated seating positions equipped with head restraints. When measured in accordance with Annex 1, the top of a head restraint located in the front center designated seating position must have a height not less than 750 mm in any position of adjustment. See exception in paragraph 5.1.3. of this regulation.
- 5.1.3. Exception. The requirements of paragraphs 5.1.1 and 5.1.2 of this regulation do not apply if the interior surface of the vehicle roofline, including the headliner, physically prevents a head restraint, located in the front outboard designated seating position, from attaining the required height. In those instances in which this head restraint cannot attain the required height, when measured in accordance with Annex 1, the maximum vertical distance between the top of the head restraint and the interior surface of the roofline, including the headliner, must not exceed 25 mm in the lowest position of seat adjustment; in any horizontal position of seat adjustment; and the highest position of head restraint adjustment intended for occupant use. Notwithstanding this exception, when measured in accordance with Annex 1, the top of a head restraint located in a front outboard designated seating position must have a height of not less than 700 mm in the lowest position of adjustment intended for occupant use.
- 5.1.4. Rear outboard designated seating positions equipped with head restraints. Except as provided in paragraph 5.1.5. of this regulation, when measured in accordance with Annex 1, the top of a head restraint located in a rear outboard designated seating position must have a height not less than 750 mm in any position of adjustment.
- 5.1.5. Exception. The requirements of paragraph 5.1.4 of this regulation do not apply if the interior surface of the vehicle roofline, including the headliner, or backlight physically prevent a head restraint, located in the rear outboard designated seating position, from attaining the required height and or folding to allow egress/ingress. In those instances in which this head restraint cannot attain the required height, when measured in accordance with Annex 1, the maximum vertical distance between the top of the head restraint and interior surface of the roofline, including the headliner, or the backlight must not exceed 25 mm in the lowest position of seat adjustment; in any horizontal position of seat adjustment; and the highest position of head restraint adjustment intended for occupant use.

- 5.1.6. Minimum width. When measured in accordance with Annex 2, the lateral width of a head restraint must be not less than 170 mm between two vertical longitudinal planes passing at 85 mm on either side of the torso reference line.
- 5.1.7. Minimum backset for front outboard designated seating positions. When measured in accordance with Annex 3, the backset must not be more than [55 mm]. For adjustable restraints, the requirements of this regulation must be met with the top of the head restraint in all height positions of adjustment between 750 mm and 800 mm, inclusive. If the top of the head restraint, in its lowest position of adjustment, is above 800 mm, the requirements of this regulation must be met at that position. If the front outboard head restraint is not attached to the seat back, the head restraint cannot be adjusted such that the backset is more than [55 mm].
- 5.1.8. Gaps within head restraint. When measured in accordance with Annex 4, there must not be any gap greater than 60 mm within the head restraint fixed at any backset position of adjustment, [unless a rear head restraint can meet the requirements of paragraph 5.2.4.].
- 5.1.9. Gaps between head restraint and the top of the seat back. When measured in accordance with Annex 4, there must not be a gap greater than 60 mm between the head restraint and the seat if the head restraint is not adjustable vertically. When measured in accordance with Annex 4, there must not be a gap greater than 25 mm between a vertically adjustable head restraint and the seat, with the head restraint adjusted to its lowest height position.
- 5.2. Static performance requirements. Each head restraint must conform to paragraphs 5.2.1. through 5.2.5. of this regulation:
- 5.2.1. Energy absorption. When the front surface of the head restraint is impacted in accordance with Annex 5 the deceleration of the head form must not exceed 785 m/s^2 (80 g) continuously for more than 3 milliseconds.
- 5.2.2. Height retention. When tested in accordance with Annex 6, the [cylindrical test device] specified in Annex 6 must return to within 13 mm of its initial reference position after application of at least a 500 N load and subsequent reduction of the load to $50 \text{ N} \pm [2.5 \text{ N}]$. During application of the initial reference load specified in Annex 6, the [cylindrical test device] must not move downward more than 25 mm.
- [5.2.3. Adjustable head restraint height retention. When tested in accordance with Annex 6, the mechanism of the adjustable head restraint shall not fail in such a way as to allow downward movement of the head restraint by more than 25 mm.
- 5.2.3.1. The mechanism shall be considered to have failed if during the test the vertical distance measured between the lowest point on the underside of the head restraint and the top of the seat back has been decreased by more than 25 mm.
- 5.2.3.2. If the design of the head restraint is such that it is not possible to measure to the top of the seat then the vertical measurement shall be taken by marking a horizontal line across the

front of the seat back at least 25 mm below the lowest point of the head restraint and the measurement shall be taken from this line to the underside of the head restraint.]

5.2.4. Backset retention and displacement. When the head restraint is tested [in the rearmost (relative to the seat) position of horizontal adjustment] in accordance with Annex 7, the head form must:

[5.2.4.1. Not be displaced more than 25 mm during the application of the initial reference moment of 37 ± 0.7 Nm;]

5.2.4.2. Not be displaced more than 102 mm perpendicularly and posterior of the displaced extended torso reference line during the application of a 373 ± 7.5 Nm moment about the H-point; and

[5.2.4.3. Return to within 13 mm of its initial reference position after the following sequence occurs: application of a 373 ± 7.5 Nm moment about the H-point; reduction of the moment to 0 Nm; and by re-application of the initial reference load 37 ± 0.7 Nm.]

5.2.5. Head restraint strength. When the head restraint is tested in accordance with Annex 7, the load applied to the head restraint must reach 890 N and remain at 890 N for a period of 5 seconds.

5.3. [Dynamic performance requirements and width. In accordance with Annex 8, at each forward-facing outboard designated seating position equipped with a head restraint, the head restraint adjusted midway between the lowest and the highest position of adjustment, and at any position of backset adjustment, must conform to the following:

5.3.1. Injury criteria. When tested in accordance with paragraph 6.3. of this regulation, during a forward acceleration of the dynamic test platform described in paragraph 6.3.1., the head restraint must:

5.3.2. Angular rotation. Limit posterior angular rotation between the head and torso of the 50th percentile male Hybrid III test dummy to 12 degrees for the dummy in all outboard designated seating positions;

5.3.3. Head injury criteria. Limit the maximum HIC_{15} value to 500. HIC_{15} is calculated as follows: For any two points in time, t_1 and t_2 , during the event which are separated by not more than a 15 millisecond time interval and where t_1 is less than t_2 , the head injury criterion (HIC_{15}) is determined using the resultant head acceleration at the center of gravity of the dummy head, a_r , expressed as a multiple of g (the acceleration of gravity) and is calculated using the expression:

[HIC calculation to be inserted]

5.4. Non-use positions. All rear head restraints and any front center head restraint may be adjusted to a position at which its height does not comply with the requirements of

paragraphs 5.1.2. and 5.1.4. of this regulation. However, in any such position, the head restraint must meet paragraphs 5.4.1, 5.4.2, or 5.4.3 of this regulation. A front outboard passenger head restraint maybe adjusted to a position at which its height does not comply with the requirements of paragraph 5.1.1. of this regulation. However, in any such position, the front outboard passenger head restraint must meet paragraph 5.4.1. of this regulation.

- 5.4.1. In all designated seating positions equipped with head restraints, except the driver's designated seating position, the head restraint must automatically return from a non-use position to a position in which its minimum height is not less than that specified in paragraphs 5.1.2. and 5.1.4. of this regulation when a 5th percentile female Hybrid III test dummy is positioned in the seat in accordance with Annex 9. At the option of the manufacturer, instead of using a 5th percentile female Hybrid III test dummy, human beings may be used as specified in Annex 9; or
- 5.4.2. In rear and front center designated seating positions equipped with head restraints, the head restraint must, when tested in accordance with Annex 9, be capable of manually rotating either forward or rearward by not less than 60 degrees from any position of adjustment intended for occupant use in which its minimum height is not less than that specified in paragraph 5.1.2. or 5.1.4. of this regulation.
- 5.4.3. When measured in accordance with Annex 9, the lower edge of the head restraint (H_{LE}) must be not more than [460 mm], but not less than 250 mm from the R-Point and the thickness (S) shall not be less than [25 mm].
- 5.4.4. When tested in accordance with Annex 9, the head restraint must cause the torso reference line angle to be at least 10 degrees closer to vertical than when the head restraint is in any position of adjustment in which its height is not less than that specified in paragraphs 5.1.1., 5.1.2., or 5.1.4. of this regulation and its backset is not more than that specified in paragraph 5.1.7. of this regulation.
- 5.5. Removability of head restraints. The head restraints must not be removable without a deliberate action distinct from any action necessary for upward head restraint adjustment.
6. Test conditions. Demonstrate compliance with paragraphs 5.1. through 5.5. of this regulation with any adjustable lumbar support adjusted to its most rearward nominal design position. If the seat cushion adjusts independently of the seat back, [position the seat cushion such that the [highest] H-point position is achieved with respect to the seat back, as measured by H-point machine, with leg and thigh segments of the H-point machine adjusted to 414 mm and 401 mm].
 - 6.1. Seat setup. Except as specified in Annex 3, if the seat back is adjustable, it is set at an initial inclination position closest to design angle as measured by the H-point machine. If there is more than one inclination position closest to design angle, set the seat back inclination to the position closest to and rearward of 25 degrees [or design angle].

- 6.2. Procedure for determining the presence of head restraints. In accordance with Annex 1, measure the height of the top of the seat back or the top of any independently adjustable seat component attached to or adjacent to the seat back between two vertical longitudinal planes passing at 85 mm on either side of the torso reference line in its highest position of adjustment using the H-point machine or an equivalent scale, which is positioned laterally within 15 mm of the centerline of the designated seating position.
7. Test procedures
 - 7.1. Dimensional requirements
 - 7.1.1. Height of head restraints. Compliance with paragraphs 5.1.1., 5.1.2., 5.1.3., 5.1.4., and 5.1.5. is demonstrated in accordance with Annex 1.
 - 7.1.2. Minimum width. Compliance with paragraph 5.1.6. is demonstrated in accordance with Annex 2.
 - 7.1.3. Minimum backset for front outboard designated seating positions. Compliance with paragraph 5.1.7. is demonstrated in accordance with Annex 3.
 - 7.1.4. Gaps within head restraints. Compliance with paragraph 5.1.8. is demonstrated in accordance with Annex 4.
 - 7.1.5. Gaps between head restraint and top of seat back. Compliance with paragraph 5.1.9. is demonstrated in accordance with Annex 4.
 - 7.2. Static Performance Requirements
 - 7.2.1. Energy Absorption. Compliance with paragraph 5.2.1. is demonstrated in accordance with Annex 5.
 - 7.2.2. Height retention. Compliance with paragraph 5.2.3. is demonstrated in accordance with Annex 6.
 - 7.2.3. Backset retention and displacement. Compliance with paragraph 5.2.4. is demonstrated in accordance with Annex 7.
 - 7.2.4. Head restraint strength. Compliance with paragraph 5.2.5. is demonstrated in accordance with Annex 7.
 - 7.3. Dynamic performance requirements. Compliance with paragraph 5.3. is demonstrated in accordance with Annex 8.
 - 7.4. Non-use positions. Compliance with paragraph 5.4. is demonstrated in accordance with Annex 9.

Annex 1

MINIMUM HEIGHT MEASUREMENT TEST PROCEDURE

1. Procedure for height measurement
 - 1.1. Demonstrate compliance with paragraphs 5.1.1. to 5.1.5. in accordance with paragraphs 1.2. and 1.3 of this annex, [using the scale incorporated into the SAE J826 (revised in July 1995) manikin or an equivalent scale], which is positioned laterally within 15 mm of the head restraint centerline. If the seat back is adjustable, it is set at an initial inclination position closest to 25 degrees from the vertical. If there is more than one inclination position closest to 25 degrees from vertical, set the seat back inclination to the position closest to and rearward of 25 degrees. If the head restraint position is independent of the seat back inclination position, [compliance is determined at a seat back inclination position closest to 25 degrees from vertical].
2. Height measurement for front outboard head restraints
 - 2.1. For head restraints in front outboard designated seating positions, adjust the top of the head restraint to the highest position and measure the height.
 - 2.2. For head restraints located in the front outboard designated seating positions that are prevented by the interior surface of the vehicle roofline from meeting the required height as specified in paragraph 5.1.1.2., measure the clearance between the top of the head restraint and the interior surface of the roofline, [with the seat adjusted to its lowest vertical position intended for occupant use], by attempting to pass a 25 mm sphere between them. Adjust the top of the head restraint to the lowest position and measure the height.
3. Height measurement for front center and rear outboard head restraints
 - 3.1. For head restraints in all designated seating positions equipped with head restraints, adjust the top of the head restraint to the lowest position other than allowed by paragraph 5.4. and measure the height.
 - 3.2. For head restraints located in rear designated seating positions that are prevented by the interior surface of the vehicle roofline or rear backlight from meeting the required height as specified in paragraph 5.1.5., measure the clearance between the top of the head restraint or the seat back and the roofline or the rear backlight, with the seat adjusted to its lowest vertical position intended for occupant use, by attempting to pass a 25 mm sphere between them.

Annex 2

MINIMUM WIDTH MEASUREMENT TEST PROCEDURE

1. Procedure for width measurement
- 1.1. Demonstrate compliance with paragraph 5.1.6. using [calipers] to measure the maximum dimension perpendicular to the vehicle vertical longitudinal plane of the intersection of the head restraint with a plane that is perpendicular to the torso reference line of SAE J826 (revised in July 1995) manikin, and 68 ± 3 mm below the top of the head restraint.

Annex 3

MINIMUM BACKSET MEASUREMENT TEST PROCEDURE

1. Procedure for backset measurement
- 1.1. Demonstrate compliance with paragraph 5.1.7. using the HRMD positioned laterally within 15 mm of the head restraint centerline. Adjust the seatback to the design angle. Adjust the front head restraint so that its top is at any height between and inclusive of 750 mm and 800 mm and its backset is in the maximum position other than allowed by paragraph 5.3. If the lowest position of adjustment is above 800 mm, adjust the head restraint to that position.

Annex 4

MAXIMUM GAP MEASUREMENT TEST PROCEDURE

1. Procedures for gap measurement
 - 1.1. Demonstrate compliance with paragraphs 5.1.8. and [5.1.9.] in accordance with the procedures of paragraphs 1.2. through 1.4. of this annex, with the head restraint adjusted to its lowest height position and any backset position intended for occupant use.
 - 1.2. The area of measurement is anywhere on the front surface of the head restraint within the following distances from the centerline of the designated seating position:
 - 1.2.1. [127 mm for seats required to have 254 mm minimum head restraint width; and]
 - 1.2.2. 85 mm [for seats required to have a 170 mm head restraint width.]
 - 1.3.1. Applying a load of no more than 5 N against the area of measurement specified in paragraph 1.2., place a 165 ± 2 mm diameter spherical head form against any gap such that at least two points of contact are made within the area. The surface roughness of the head form is less than 1.6 μm , root mean square.
 - 1.3.2. Determine the gap dimension by measuring the straight line distance between the inner edges of the two furthest contact points, as shown in Figures 2 and 3.

The United States are considering using Regulation No. 17 as an alternative for measurement of projected gaps between the head restraints and the seat.

Annex 5

ENERGY ABSORPTION TEST PROCEDURE

1. Procedures for energy absorption. Demonstrate compliance with paragraph 5.2.1. of this regulation in accordance with paragraphs 1.1. through 1.4. of this annex, and the adjustable head restraints in any height and backset position of adjustment.

- [1.1. Seat setting up

The seat, as mounted in the vehicle, shall be firmly secured to the test bench with the attachment parts provided by the manufacturer, so as to remain stationary when the impact is applied.

The seat-back, if adjustable, shall be locked in the design position specified by the vehicle manufacturer.

If the seat is fitted with a head restraint, the head restraint shall be mounted on the seat-back as in the vehicle. Where the head restraint is separate, it shall be secured to the part of the vehicle structure to which it is normally attached.]

- 1.2. Test equipment

- 1.2.1. Use an impactor with a semispherical head form of a 165 ± 2 mm diameter and a surface roughness of less than $1.6 \mu\text{m}$, root mean square for the impacting part of the impactor. The head form and associated base have a combined mass such that at a speed of 24.1 ± 0.5 km/h at the time of impact energy of 152 ± 6 Joule will be reached.

- 1.2.2. Instrument the impactor with an acceleration sensing device whose output is recorded in a data channel that conforms to the requirements for a 600 Hz channel class filter as specified in ISO Standard 6487 (2002); The axis of the acceleration-sensing device coincides with the geometric center of the head form and the direction of impact. As an alternative the impactor can be equipped with 2 decelerometers sensing in the direction of impact and placed symmetrically in comparison to the geometric center of the spherical head form. In this case the deceleration rate shall be taken as the simultaneous average of the readings on the two decelerometers.

- 1.3. Accuracy of the test equipment

The recording instruments used shall be such that measurements can be made with the following degrees of accuracy:

- 1.3.1. Acceleration:
Accuracy = + 5 per cent of the actual value;
Cross-axis sensitivity = < 5 per cent of the lowest point on the scale.

- 1.3.2. Speed:
Accuracy: + 2.5 per cent of the actual value;
Sensitivity: 0.5 km/h.
- 1.3.3. Time recording:
(a) The instrumentation shall enable the action to be recorded throughout its duration and readings to be made to within one one-thousandth of a second;
(b) The beginning of the impact at the moment of first contact between the headform and the item being tested shall be detected on the recordings used for analyzing the test.
- 1.4. Test procedure
- 1.4.1. Propel the impactor toward the head restraint. At the time of impact, the longitudinal axis of the impactor is within ± 2 degrees of being horizontal and parallel to the vehicle longitudinal axis and the impactor at a speed of not more than 24.1 km/h.
- 1.4.2. Impact the anterior surface of the seat or head restraint at any point with a height greater than 635 mm [from the R-point] and within a distance of the head restraint vertical centerline of 70 mm.

Annex 6

HEIGHT RETENTION TEST PROCEDURE

1. Procedures for height retention
 - 1.1. Demonstrate compliance with paragraph 5.2.3. of this regulation in accordance with paragraphs 1.2. through 1.3. of this annex.
 - 1.2. Adjust the adjustable head restraint so that its top is at any of the following height positions at any backset position:
 - 1.2.1. For front outboard designated seating positions:
 - 1.2.1.1. The highest position; and
 - 1.2.1.2. Not less than, but closest to 800 mm; and
 - 1.2.2. For rear outboard and front center designated seating positions
 - 1.2.2.1. The highest position; and
 - 1.2.2.2. Not less than, but closest to 750 mm.
 - 1.3. Orient a cylindrical test device having a 165 ± 2 mm diameter in plane view (perpendicular to the axis of revolution), and a 152 mm length in profile (through the axis of revolution) with a surface roughness of less than $1.6 \mu\text{m}$, root mean square, such that the axis of the revolution is horizontal and in the longitudinal vertical plane through the longitudinal centerline of the head restraint. Position the midpoint of the bottom surface of the cylinder in contact with the head restraint.
 - 1.3.1. Increase the load at the rate of 250 ± 50 N/minute to at least 500 N and maintain this load for not less than 5 seconds.
 - 1.3.2. Reduce the load to 0 N and determine the position of the cylindrical device with respect to its initial reference position.

Annex 7

BACKSET RETENTION, DISPLACEMENT, AND STRENGTH TEST PROCEDURES

1. Procedures for backset retention, displacement, and strength
- 1.1. Demonstrate compliance with paragraphs 5.2.4. and 5.2.5. of this regulation in accordance with paragraphs 1.2. and 1.3. of this annex. The load vectors that generate moment on the head restraint are initially contained in a vertical plane parallel to the vehicle longitudinal centerline.
- 1.2. Backset retention and displacement
- 1.2.1. Adjust the head restraint [to the highest position of vertical adjustment intended for occupant use] or [so that its top is at a height closest to and not less than:
 - 1.2.1.1. 800 mm for front outboard designated seating positions (or the highest position of adjustment for head restraints subject to paragraph 5.1.3 of this regulation); and
 - 1.2.1.2. 750 mm for rear outboard [and front center] designated seating positions equipped with head restraints (or the highest position of adjustment for rear head restraints subject to paragraph 5.1.5).]
- 1.2.3. Adjust the head restraint to [in the rearmost (relative to the seat) position of horizontal adjustment] backset position.
- 1.2.4. In the seat, place a test device having the back pan dimensions and torso reference line (vertical center line), when viewed laterally, with the head room probe in the full back position, of the three dimensional H-point machine.
- 1.2.5. Establish the displaced torso reference line by creating a posterior moment of 373 ± 7.5 Nm about the [H-point/R-point] by applying a force to the seat back through the back pan at the rate of [2.5 Nm/second to 37.3 Nm/second]. The initial location on the back pan of the moment generating force vector has a height of $290 \text{ mm} \pm 13 \text{ mm}$. Apply the force vector normal to the torso reference line and maintain it within 2 degrees of a vertical plane parallel to the vehicle longitudinal centerline. Constrain the back pan to rotate about the [H-point/R-point]. Rotate the force vector direction with the back pan.
- 1.2.6. Maintain the position of the back pan as established in paragraph 1.2.5. of this annex. Using a 165 ± 2 mm diameter spherical head form with a surface roughness of less than $1.6 \mu\text{m}$, root mean square, establish the head form initial reference position by applying, perpendicular to the displaced torso reference line, a rearward initial load at the seat centerline at a height 65 ± 3 mm below the top of the head restraint that will produce a 36.5 ± 0.5 Nm moment about the [H-point/R-point]. [Measure the rearward

displacement of the head form during the application of the load].

- 1.2.7. Increase the initial load at the rate of [2.5 Nm/second to 37.3 Nm/second] until a 373 ± 7.5 Nm moment about the [H-point/R-point] is produced. Maintain the load level producing that moment for not less than 5 seconds and then measure the rearward displacement of the head form relative to the displaced torso reference line.
- 1.2.8. Reduce the load at the rate of [2.5 Nm/second to 37.3 Nm/second] until 0 Nm. Wait 10 minutes. Re-load to 37 ± 0.7 Nm about the [H-point/R-point]. While maintaining the load level producing that moment, measure the [rearward] displacement of the head form position with respect to its initial reference position.

1.3. Strength

Increase the load specified in paragraph 1.2.8 of this annex at the rate of [5 N/second to 200 N/second] to $885 \text{ N} \pm 5 \text{ N}$ and maintain the applied load for not less than 5 seconds.

Annex 8

DYNAMIC PERFORMANCE TEST PROCEDURE

1. Procedures for dynamic performance
- 1.1. Demonstrate compliance with paragraph 5.3. in accordance with this annex, using a 50th percentile male Hybrid III test dummy, and with the head restraint midway between the lowest and the highest position of adjustment, and at any position of backset adjustment.
- 1.2. Mount the vehicle on a dynamic test platform so that the longitudinal centerline of the vehicle is parallel to the direction of the test platform travel and so that movement between the base of the vehicle and the test platform is prevented. Instrument the platform with an accelerometer and data processing system. Position the accelerometer sensitive axis parallel to the direction of test platform travel.
- 1.3. Remove the tyres, wheels, fluids, and all unsecured components. Remove or rigidly secure the engine, transmission, axles, exhaust, vehicle frame and any other vehicle component necessary to assure that all points on the acceleration versus time plot measured by an accelerometer on the dynamic test platform fall within the corridor described in Figure 1 and Table 1.
- 1.4. Place any moveable windows in the fully open position.
- 1.5. Seat adjustment. At each outboard designated seating position, using any control that primarily moves the entire seat vertically, [place the seat in the lowest position]. Using any control that primarily moves the entire seat in the fore and aft directions, place the seat midway between the forwardmost and rearmost position. If an adjustment position does not exist midway between the forwardmost and rearmost positions, the closest adjustment position to the rear of the midpoint is used. Adjust the seat cushion and seat back, without using any controls that move the entire seat, as required by paragraphs 6. and 6.1. of this regulation. If the specified position of the H-point can be achieved with a range of seat cushion inclination angles, adjust the seat inclination such that the most forward part of the seat cushion is [at its lowest position] with respect to the most rearward part. If the head restraint is adjustable, adjust the top of the head restraint to a position midway between the lowest position of adjustment and the highest position of adjustment. If an adjustment position midway between the lowest and the highest position does not exist, adjust the head restraint to a position below and nearest to midway between the lowest position of adjustment and the highest position of adjustment.
- 1.6. Seat belt adjustment. Prior to placing the Type 2 seat belt around the test dummy, fully extend the webbing from the seat belt retractor(s) and release it three times to remove slack. If an adjustable seat belt D-ring anchorage exists, place it in the adjustment position closest to the mid-position. If an adjustment position does not exist midway between the highest and lowest position, the closest adjustment position above the

midpoint is used.

1.7. Dress and adjust each test dummy as follows:

Each test dummy is clothed in a form fitting cotton stretch short sleeve shirt with above-the-elbow sleeves and above-the-knee length pants. The weight of the shirt or pants shall not exceed 0.25 pounds each. Each foot of the test dummy is equipped with a size 11XW shoe which meets the configuration size, sole, and heel thickness specifications of MIL-S-13192 change "P" and whose weight is 1.25 ± 0.2 pounds.

Limb joints are set at 1 g, barely restraining the weight of the limb when extended horizontally. Leg joints are adjusted with the torso in the supine position.

1.8. Test dummy positioning procedure. Place a test dummy at each outboard designated seating position equipped with a head restraint.

1.9. Head. The transverse instrumentation platform of the head is level within 1/2 degree. To level the head of the test dummy, the following sequence is followed. First, adjust the position of the H point 1/ to level the transverse instrumentation platform of the head of the test dummy. If the transverse instrumentation platform of the head is still not level, then adjust the pelvic angle of the test dummy. If the transverse instrumentation platform of the head is still not level, then adjust the neck bracket of the dummy the minimum amount necessary from the non-adjusted "0" setting to ensure that the transverse instrumentation platform of the head is horizontal within 1/2 degree. The test dummy remains within the limits specified in footnote 2 after any adjustment of the neck bracket.

1.10. Upper arms and hands. Position each test dummy as specified below:

1.10.1. The driver's upper arms shall be adjacent to the torso with the centerlines as close to a vertical plane as possible.

1.10.2. The passenger's upper arms shall be in contact with the seat back and the sides of the torso.

1.10.3. The palms of the drivers test dummy shall be in contact with the outer part of the steering wheel rim at the rim's horizontal centerline. The thumbs shall be over the steering wheel rim and shall be lightly taped to the steering wheel rim so that if the hand

1/ The H-points of the driver and passenger test dummies shall coincide within 1/2 inch in the vertical dimension and 1/2 inch in the horizontal dimension of a point 1/4 inch below the position of the H-point determined by using the equipment and procedures specified in SAE J826 (APR 1980) except that the length of the lower leg and thigh segments of the H-point machine shall be adjusted to 16.3 and 15.8 inches, respectively, instead of the 50th percentile values specified in Table 1 of SAE J826.

- of the test dummy is pushed upward by a force of not less than 2 pounds and not more than 5 pounds, the tape shall release the hand from the steering wheel rim.
- 1.10.4. The palms of the passenger test dummy shall be in contact with the outside of the thigh. The little finger shall be in contact with the seat cushion.
- 1.11. Torso. Position each test dummy as specified in [insert text from S10.4.1.1, S10.4.1.2, and S10.4.2.1 of para. 571.208], except that the midsagittal plane of the dummy is aligned within 15 mm of the head restraint centerline. If the midsagittal plane of the dummy cannot be aligned within 15 mm of the head restraint centerline then align the midsagittal plane of the dummy as close as possible to the head restraint centerline.
- 1.12. Legs. Position each test dummy as follows:
The upper legs of the driver and passenger test dummies shall rest against the seat cushion to the extent permitted by placement of the feet. The initial distance between the outboard knee clevis flange surfaces shall be 10.6 inches. To the extent practicable, the left leg of the driver dummy and both legs of the passenger dummy shall be in vertical longitudinal planes. To the extent practicable, the right leg of the driver dummy shall be in a vertical plane. Final adjustment to accommodate the placement of feet in various passenger compartment configurations is permitted.
- 1.13. Feet. Position each test dummy as specified in [S10.6 of para. 571.208 2/] except that for rear outboard designated seating positions the feet of the test dummy are placed flat on the floorpan and beneath the front seat as far forward as possible without front seat interference. For rear outboard designated seating position, if necessary, the distance between the knees can be changed in order to place the feet beneath the seat.
- 2.1. Accelerate the dynamic test platform to 17.3 ± 0.6 km/h. All of the points on the acceleration vs. time curve fall within the corridor described in Figure 1 and Table 5 when filtered to channel class 60, as specified in the SAE Recommended Practice J211/1 (revised in March 95). Measure the maximum posterior angular displacement.
- 2.2. Calculate the angular displacement from the output of instrumentation placed in the torso and head of the test dummy and an algorithm capable of determining the relative angular displacement to within one degree and conforming to the requirements of a 600 Hz channel class, as specified in SAE Recommended Practice J211/1, (revised in March 95). No data generated after 200 ms from the beginning of the forward acceleration are used in determining angular displacement of the head with respect to the torso.
- 2.3. Calculate the HIC_{15} from the output of instrumentation placed in the head of the test dummy, using the equation in paragraph 5.2.1.2. of this regulation and conforming to

2/ <http://ecfr.gpoaccess.gov/cgi/t/text/text-idx?c=ecfr&sid=f71ca7d062d9b2fa66b9ddb3fec6e0e3&rgn=div5&view=text&node=49:5.1.2.3.36&idno=49#49:5.1.2.3.36.2.4.64>.

the requirements for a 1000 Hz channel class as specified in SAE Recommended Practice J211/1 (revised March 95). No data generated after 200 ms from the beginning of the forward acceleration are used in determining HIC.

Annex 9

NON-USE POSITION TEST PROCEDURE

- 1.1. Procedures for folding or retracting head restraints in all designated seating positions equipped with head restraints, except the driver's designated seating position.
- 1.2. Demonstrate compliance with paragraph 5.4.1., with the ignition on, and using a 5th percentile female Hybrid III test dummy in accordance with paragraphs 1.2.1. to 1.2.4. of this annex, or a human surrogate in accordance with paragraph 1.3. of this annex:
 - 1.2.1. Position the test dummy in the seat such that the dummy's midsagittal plane is aligned within the 15 mm of the seating position centerline and is parallel to a vertical plane parallel to the vehicle longitudinal centerline.
 - 1.2.2. Hold the dummy's thighs down and push rearward on the upper torso to maximize the dummy's pelvic angle.
 - 1.2.3. Place the legs as close as possible to 90 degrees to the thighs. Push rearward on the dummy's knees to force the pelvis into the seat so there is no gap between the pelvis and the seat back or until contact occurs between the back of the dummy's calves and the front of the seat cushion such that the angle between the dummy's thighs and legs begins to change.
 - 1.2.4. Note the position of the head restraint. Remove the dummy from the seat. If the head restraint returns to a retracted position upon removal of the dummy, manually place it in the noted position. Determine compliance with the height requirements of paragraphs 5.1.1. and 5.1.2, and 5.1.4 of this regulation by using the test procedures of Annex 1.
- 1.3. Human surrogate. For paragraphs 1.2.1. to 1.2.4 of this annex, instead of using the 5th percentile adult female test dummy, a human being who weighs between 47 and 51 kg, and who is between 140 and 150 cm tall may be used.
 - 1.3.1. The human surrogate shall be dressed in a cotton T-shirt, full length cotton trousers, and sneakers. Specified weights and heights include clothing.
- 1.4. Procedures for the rear and front center designated seating positions equipped with head restraints.
 - 1.4.1. Demonstrate compliance with paragraph 5.4.2 of this regulation in accordance with the following procedure:
 - 1.4.2. Place the head restraint in any position meeting the requirements of paragraph 5.1.2. or 5.1.4. of this regulation;

- 1.4.3. Mark a line on the head restraint. Measure the angle or range of angles of the head restraint reference line as projected onto a vertical longitudinal vehicle plane;
- 1.4.4. Fold or retract the head restraint to a position in which its minimum height is less than that specified in paragraphs 5.1.2. or 5.1.4. of this regulation;
- 1.4.5. Determine the minimum change in the head restraint reference line angle as projected onto a vertical longitudinal vehicle plane from the angle or range of angles measured in paragraph 1.4.3. of this annex.
- [1.4. Demonstrate compliance with paragraph 5.4.3. of this regulation in accordance with paragraphs 1.4.1. through 1.4.4. of this annex.
- 1.4.1. All lines, including the projection of the reference line, shall be drawn in the vertical median design torso reference plane of the seat, the intersection of such plane with the seat determining the contour of the head restraint and of the seat-back (see Figure 4 of this annex).
- 1.4.2. Adjust the head restraint to its non use position.
- 1.4.3. Determine the height H_{LE} of the lower edge of the head restraint as shown in Figure 4.
- 1.4.4. The projection of the reference line of the manikin is then, in the seat concerned, drawn in the plane specified in paragraph 1.4.1. of this annex above. The tangent T_H to the bottom of the head restraint is drawn perpendicular to the reference line.
- 1.4.5. The distance " H_{LE} " from the R-point to the tangent T_H is the height to be taken into consideration in implementing the requirements of paragraph 5.3.2.2. of this regulation.
- 1.4.7. Measure S at the lower edge of the head restraint as shown in Figure 4.
- 1.4.8. The projection of the reference line of the manikin is, in the seat concerned, drawn in the plane specified in paragraph 1.1. above. A tangent T_S is drawn above and parallel to the tangent T_H , as specified in paragraph 1.4.5., with a distance of not more than [25 mm] above. A parallel P to the torso reference line passing through the intersection of tangent T_S with the surface of the head restraint is drawn in the same plane. The distance "S", measured perpendicular to the torso reference line, from parallel P to the surface of the seat back at this position is the thickness to be taken into consideration in implementing the requirements of paragraph 5.3.2.2. of this regulation.]

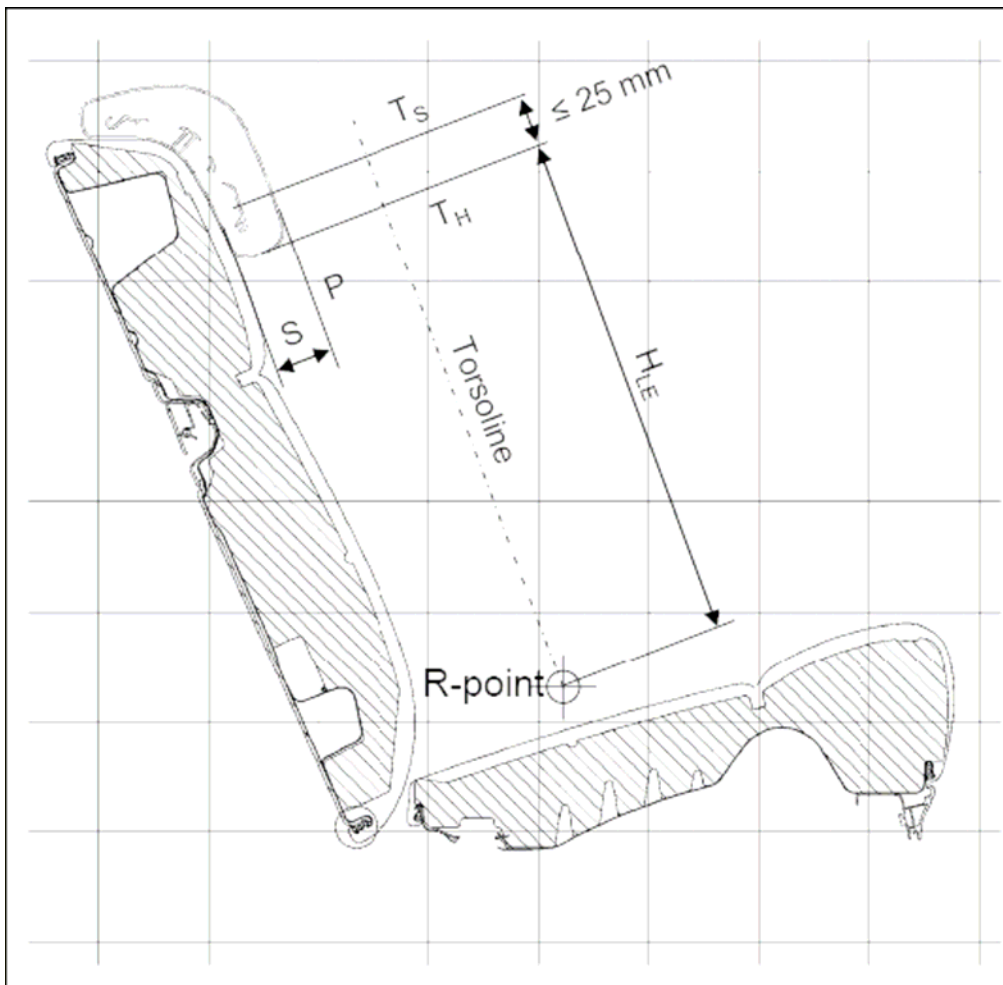

Figure 4

[Annex 10DESCRIPTION OF THE THREE DIMENSIONAL "H" POINT MACHINE 1/
(3DH-machine)

1. Back and seat pans. The back and seat pans are constructed of reinforced plastic and metal; they stimulate the human torso and thigh and are mechanically hinged at the "H" point. A quadrant is fastened to the probe hinged at the "H" point to measure the actual torso angle. An adjustable thigh bar, attached to the seat pan, establishes the thigh centreline and serves as a baseline for the hip angle quadrant.
2. Body and leg elements. Lower leg segments are connected to the seat pan assembly at the T-bar joining the knees, which is a lateral extension of the adjustable thigh bar. Quadrants are incorporated in the lower leg segments to measure knee angles. Shoe and foot assemblies are calibrated to measure the foot angle. Two spirit levels orient the device in space. Body element weights are placed at the corresponding centres of gravity to provide seat penetration equivalent to a 76 kg male. All joints of the 3DH machine should be checked for free movement without encountering noticeable friction.]

1/ For details of the construction of the 3DH-machine refer to Society of Automotive Engineers (SAE), 400 Commonwealth Drive, Warrendale, Pennsylvania 15096, United States of America. The machine corresponds to that described in ISO Standard 6549-1980.

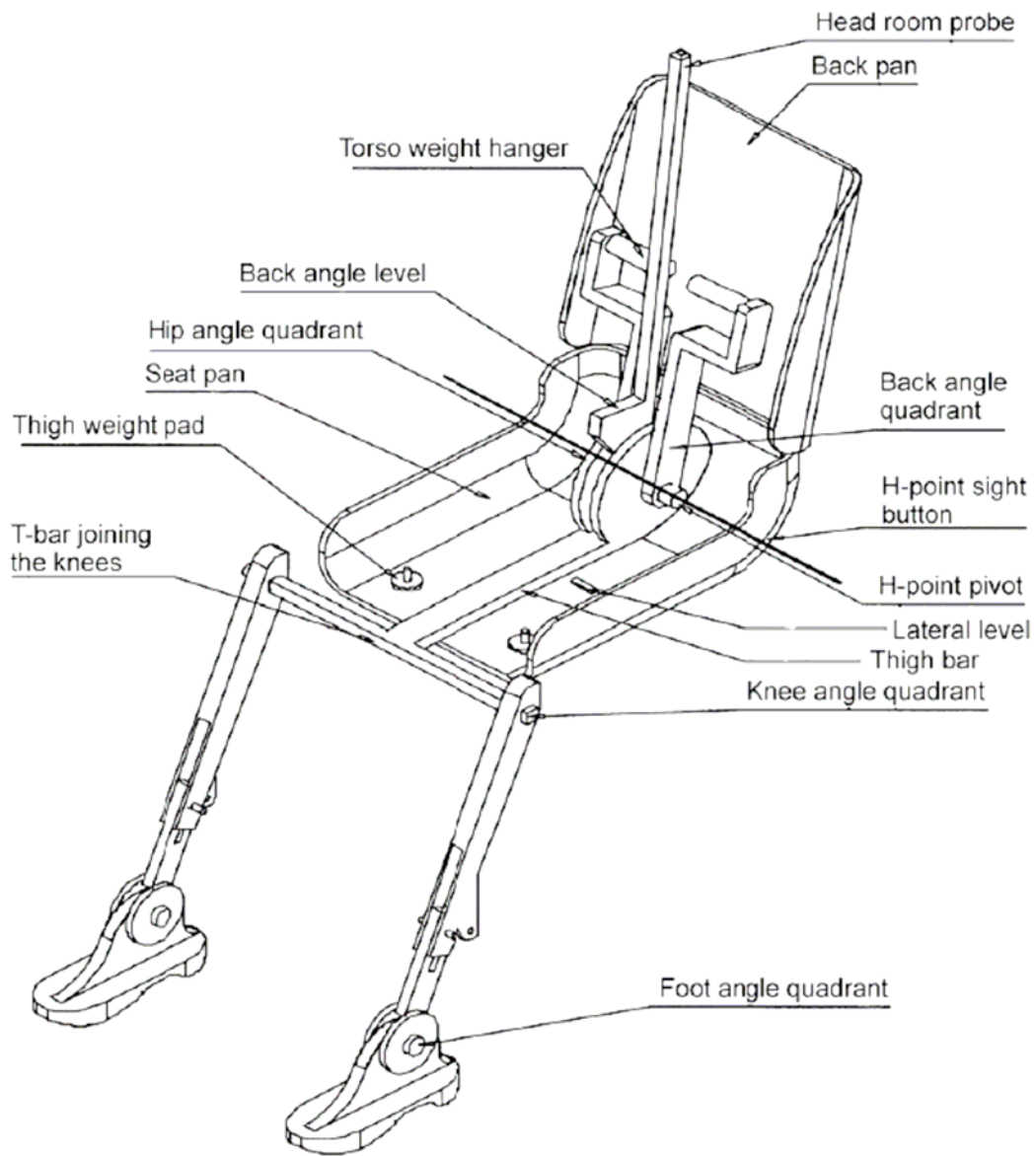

Figure 1 - 3DH-machine elements designation

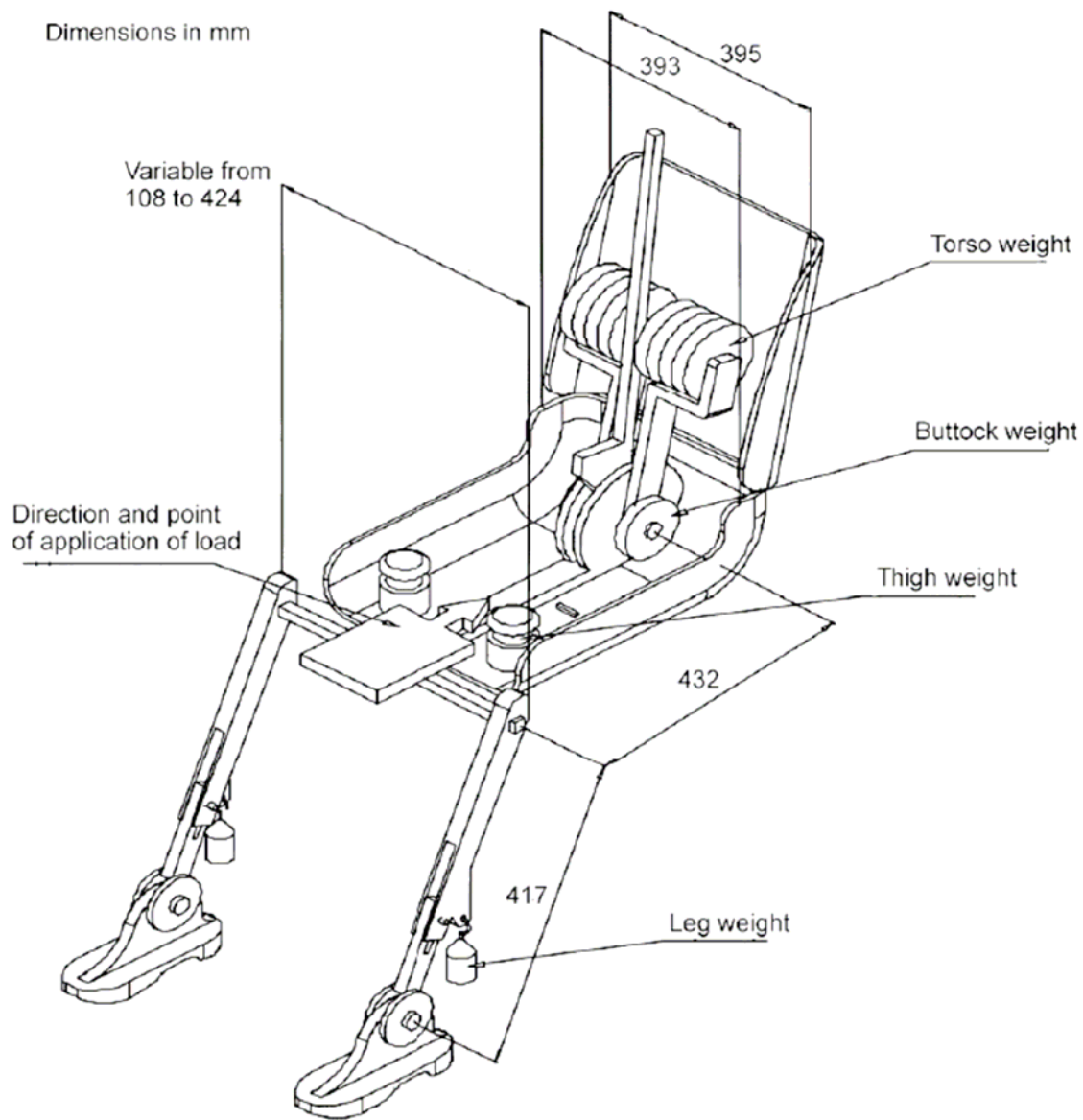

Figure 2 - Dimensions of the 3DH-machine elements and load distribution

Annex 11

[PROCEDURE FOR DETERMINING THE "H" POINT AND THE ACTUAL TORSO ANGLE FOR SEATING POSITIONS IN MOTOR VEHICLES

1. PURPOSE

- 1.1. The procedure described in this annex is used to establish the "H" point location and the actual torso angle for one or several seating positions in a motor vehicle and to verify the relationship of measured data to design specifications given by the vehicle manufacturer. 1/

2. DEFINITIONS

For the purposes of this annex:

- 2.1. "Reference data" means one or several of the following characteristics of a seating position:
- 2.1.1. the "H" point and the "R" point and their relationship,
 - 2.1.2. the actual torso angle and the design torso angle and their relationship.
- 2.2. "Three-dimensional 'H' point machine" (3DH-machine) means the device used for the determination of "H" points and actual torso angles. This device is described in Appendix 1 to this annex;
- 2.3. "'H' point" means the pivot centre of the torso and thigh of the 3DH-machine installed in the vehicle seat in accordance with paragraph 4. below. The "H" point is located in the centre of the centreline of the device which is between the "H" point sight buttons on either side of the 3DH-machine. The "H" point corresponds theoretically to the "R" point (for tolerances see paragraph 3.2.2. below). Once determined in accordance with the procedure described in paragraph 4., the "H" point is considered fixed in relation to the seat-cushion structure and to move with it when the seat is adjusted;
- 2.4. "'R' point" or "seating reference point" means a design point defined by the vehicle manufacturer for each seating position and established with respect to the three-dimensional reference system;
- 2.5. "Torso-line" means the centreline of the probe of the 3DH-machine with the probe in the fully rearward position;

1/ In any seating position other than front seats where the "H" point cannot be determined using the "three-dimensional 'H' point machine" or procedures, the "R" point indicated by the manufacturer may be taken as a reference at the discretion of the competent authority.

- 2.6. "Actual torso angle" means the angle measured between a vertical line through the "H" point and the torso line using the back angle quadrant on the 3DH-machine. The actual torso angle corresponds theoretically to the design torso angle (for tolerances see paragraph 3.2.2. below);
- 2.7. "Design torso angle" means the angle measured between a vertical line through the "R" point and the torso line in a position which corresponds to the design position of the seat-back established by the vehicle manufacturer;
- 2.8. "Centre plane of occupant" (C/LO) means the median plane of the 3DH-machine positioned in each designated seating position; it is represented by the co-ordinate of the "H" point on the "Y" axis. For individual seats, the centre plane of the seat coincides with the centre plane of the occupant. For other seats, the centre plane of the occupant is specified by the manufacturer;
- 2.9. "Three dimensional reference system" means a system as described in Appendix 2 to this annex;
- 2.10. "Fiducial marks" are physical points (holes, surfaces, marks or indentations) on the vehicle body as defined by the manufacturer;
- 2.11. "Vehicle measuring attitude" means the position of the vehicle as defined by the co-ordinates of fiducial marks in the three-dimensional reference system.

3. REQUIREMENTS

3.1. Data presentation

For each seating position where reference data are required in order to demonstrate compliance with the provisions of the present Regulation, all or an appropriate selection of the following data shall be presented in the form indicated in Appendix 3 to this annex:

- 3.1.1. the co-ordinates of the "R" point relative to the three-dimensional reference system;
- 3.1.2. the design torso angle;
- 3.1.3. all indications necessary to adjust the seat (if it is adjustable) to the measuring position set out in paragraph 4.3. below.

3.2. Relationship between measured data and design specifications

- 3.2.1. The co-ordinates of the "H" point and the value of the actual torso angle obtained by the procedure set out in paragraph 4. below shall be compared, respectively, with the co-ordinates of the "R" point and the value of the design torso angle indicated by the vehicle manufacturer.

- 3.2.2. The relative positions of the "R" point and the "H" point and the relationship between the design torso angle and the actual torso angle shall be considered satisfactory for the seating position in question if the "H" point, as defined by its co-ordinates, lies within a square of 50 mm side length with horizontal and vertical sides whose diagonals intersect at the "R" point, and if the actual torso angle is within 5 degree of the design torso angle.
- 3.2.3. If these conditions are met, the "R" point and the design torso angle, shall be used to demonstrate compliance with the provisions of this Regulation.
- 3.2.4. If the "H" point or the actual torso angle does not satisfy the requirements of paragraph 3.2.2. above, the "H" point and the actual torso angle shall be determined twice more (three times in all). If the results of two of these three operations satisfy the requirements, the conditions of paragraph 3.2.3. above shall apply.
- 3.2.5. If the results of at least two of the three operations described in paragraph 3.2.4. above do not satisfy the requirements of paragraph 3.2.2. above, or if the verification cannot take place because the vehicle manufacturer has failed to supply information regarding the position of the "R" point or regarding the design torso angle, the centroid of the three measured points or the average of the three measured angles shall be used and be regarded as applicable in all cases where the "R" point or the design torso angle is referred to in this Regulation.

4. PROCEDURE FOR "H" POINT AND ACTUAL TORSO ANGLE DETERMINATION

- 4.1. The vehicle shall be preconditioned at the manufacturer's discretion, at a temperature of 20 ± 10 °C to ensure that the seat material reaches room temperature. If the seat to be checked has never been sat upon, a 70 to 80 kg person or device shall sit on the seat twice for one minute to flex the cushion and back. At the manufacturer's request, all seat assemblies shall remain unloaded for a minimum period of 30 minutes prior to installation of the 3DH-machine.
- 4.2. The vehicle shall be at the measuring attitude defined in paragraph 2.11. above.
- 4.3. The seat, if it is adjustable, shall be adjusted first to the rearmost normal driving or riding position, as indicated by the vehicle manufacturer, taking into consideration only the longitudinal adjustment of the seat, excluding seat travel used for purposes other than normal driving or riding positions. Where other modes of seat adjustment exist (vertical, angular, seat-back, etc.) these will be then adjusted to the position specified by the vehicle manufacturer. For suspension seats, the vertical position shall be rigidly fixed corresponding to a normal driving position as specified by the manufacturer.
- 4.4. The area of the seating position contacted by the 3DH-machine shall be covered by a muslin cotton, of sufficient size and appropriate texture, described as a plain cotton fabric having 18.9 threads per cm² and weighing 0.228 kg m² or knitted or non-woven fabric having equivalent characteristics. If the test is run on a seat outside the vehicle,

the floor on which the seat is placed shall have the same essential characteristics (2/) as the floor of the vehicle in which the seat is intended to be used.

- 4.5. Place the seat and back assembly of the 3DH-machine so that the centre plane of the occupant (C/LO) coincides with the centre plane of the 3DH-machine. At the manufacturer's request, the 3DH-machine may be moved inboard with respect to the C/LO if the 3DH-machine is located so far outboard that the seat edge will not permit levelling of the 3DH-machine.
- 4.6. Attach the foot and lower leg assemblies to the seat pan assembly, either individually or by using the T-bar and lower leg assembly. A line through the "H" point sight buttons shall be parallel to the ground and perpendicular to the longitudinal centre plane of the seat.
- 4.7. Adjust the feet and leg positions of the 3DH-machine as follows:
 - 4.7.1. Designated seating position: driver and outside front passenger.
 - 4.7.1.1. Both feet and leg assemblies shall be moved forward in such a way that the feet take up natural positions on the floor, between the operating pedals if necessary. Where possible the left foot shall be located approximately the same distance to the left of the centre plane of the 3DH-machine as the right foot is to the right. The spirit level verifying the transverse orientation of the 3DH-machine is brought to the horizontal by readjustment of the seat pan if necessary, or by adjusting the leg and foot assemblies towards the rear. The line passing through the "H" point sight buttons shall be maintained perpendicular to the longitudinal centre plane of the seat.
 - 4.7.1.2. If the left leg cannot be kept parallel to the right leg and the left foot cannot be supported by the structure, move the left foot until it is supported. The alignment of the sight buttons shall be maintained.
 - 4.7.2. Designated seating position: For outboard rear seats or auxiliary seats, the legs are located as specified by the manufacturer. If the feet then rest on parts of the floor which are at different levels, the foot which first comes into contact with the front seat shall serve as a reference and the other foot shall be so arranged that the spirit level giving the transverse orientation of the seat of the device indicates the horizontal.
 - 4.7.3. Other designated seating positions: The general procedure indicated in paragraph 4.7.1. above shall be followed except that the feet shall be placed as specified by the vehicle manufacturer.
- 4.8. Apply lower leg and thigh weights and level the 3DH-machine.

2/ Tilt angle, height difference with a seat mounting, surface texture, etc.

- 4.9. Tilt the back pan forward against the forward stop and draw the 3DH-machine away from the seat-back using the T-bar. Reposition the 3DH-machine on the seat by one of the following methods:
 - 4.9.1. If the 3DH-machine tends to slide rearward, use the following procedure. Allow the 3DH-machine to slide rearward until a forward horizontal restraining load on the T-bar is no longer required i.e. until the seat pan contacts the seat-back. If necessary, reposition the lower leg.
 - 4.9.2. If the 3DH-machine does not tend to slide rearward, use the following procedure. Slide the 3DH-machine rearwards by applying a horizontal rearward load to the T-bar until the seat pan contacts the seat-back (see Figure 2 of Appendix 1 to this annex).
- 4.10. Apply a 100 " 10 N load to the back and pan assembly of the 3DH-machine at the intersection of the hip angle quadrant and the T-bar housing. The direction of load application shall be maintained along a line passing by the above intersection to a point just above the thigh bar housing (see Figure 2 of Appendix 1 to this annex). Then carefully return the back pan to the seat-back. Care must be exercised throughout the remainder of the procedure to prevent the 3DH-machine from sliding forward.
- 4.11. Install the right and left buttock weights and then, alternately, the eight torso weights. Maintain the 3DH-machine level.
- 4.12. Tilt the back pan forward to release the tension on the seat-back. Rock the 3DH-machine from side to side through 10 degrees arc (5 degrees to each side of the vertical centre plane) for three complete cycles to release any accumulated friction between the 3DH-machine and the seat.

During the rocking action, the T-bar of the 3DH-machine may tend to diverge from the specified horizontal and vertical alignment. The T-bar must therefore be restrained by applying an appropriate lateral load during the rocking motions. Care shall be exercised in holding the T-bar and rocking the 3DH-machine to ensure that no inadvertent exterior loads are applied in a vertical or fore and aft direction.

The feet of the 3DH-machine are not to be restrained or held during this step. If the feet change position, they should be allowed to remain in that attitude for the moment.

Carefully return the back pan to the seat-back and check the two spirit levels for zero position. If any movement of the feet has occurred during the rocking operation of the 3DH-machine, they must be repositioned as follows:

Alternately, lift each foot off the floor the minimum necessary amount until no additional foot movement is obtained. During this lifting, the feet are to be free to rotate; and no forward or lateral loads are to be applied. When each foot is placed back in the down position, the heel is to be in contact with the structure designed for this.

Check the lateral spirit level for zero position; if necessary, apply a lateral load to the top of the back pan sufficient to level the 3DH-machine's seat pan on the seat.

- 4.13. Holding the T-bar to prevent the 3DH-machine from sliding forward on the seat cushion, proceed as follows:
- (a) return the back pan to the seat-back;
 - (b) apply and release a horizontal rearward load, not to exceed 25 N, to the back angle bar at a height approximately at the centre of the torso weights until the hip angle quadrant indicates that a stable position has been reached after load release. Care shall be exercised to ensure that no exterior downward or lateral loads are applied to the 3DH-machine. If another level adjustment of the 3DH-machine is necessary, rotate the back pan forward, re-level, and repeat the procedure from paragraph 4.12.
- 4.14. Take all measurements:
- 4.14.1. The co-ordinates of the "H" point are measured with respect to the three-dimensional reference system.
 - 4.14.2. The actual torso angle is read at the back angle quadrant of the 3DH-machine with the probe in its fully rearward position.
- 4.15. If a re-run of the installation of the 3DH-machine is desired, the seat assembly should remain unloaded for a minimum period of 30 minutes prior to the re-run. The 3DH-machine should not be left loaded on the seat assembly longer than the time required to perform the test.
- 4.16. If the seats in the same row can be regarded as similar (bench seat, identical seats, etc.) only one "H" point and one "actual torso angle" shall be determined for each row of seats, the 3DH-machine described in Appendix 1 to this annex being seated in a place regarded as representative for the row. This place shall be:
- 4.16.1. in the case of the front row, the driver's seat;
 - 4.16.2. in the case of the rear row or rows, an outer seat.]

Table 1 – Sled pulse corridor reference point locations:

Reference Point	Time (ms)	Acceleration (m/s ²)
A	0	10
B	28	94
C	60	94
D	92	0
E	4	0
F	38.5	80
G	49.5	80

H	84	0
---	----	---

Figure 1 - Sled pulse acceleration corridor. The target acceleration with time expressed in milliseconds is $a = 86 \sin(\pi t/88) \text{ m/s}^2$, for $v = 17.3 \pm 0.6 \text{ km/h}$. The time zero for the test is defined by the point when the sled acceleration achieves 2.5 m/s^2 (0.25 g).

[Insert corridor]

Figure 2 - Measurement of a vertical gap "a".

[Insert drawing]

Figure 3 - Measurement of a horizontal gap "a".

[Insert drawing]
