

**OICA Draft Proposal for the ELSA Meeting
November 12-14 in Paris**

ELECTRICAL SAFETY PROVISIONS FOR VEHICLES Post Crash

1. General

This module shall apply to the power train of electric vehicles, hybrid vehicles and fuel cell vehicles, and the high voltage components and systems which are galvanically connected to the high voltage bus of the power train following vehicle crash test(s). The crash test(s) to be used for purposes of evaluating compliance to these requirements are those specified within existing regulations of the contracting parties.

2. Definitions

For the purpose of this regulation the following definitions apply:

2-1 Electric power train

the electrical circuit which may include the RESS, the energy conversion system, the electronic converters, the traction motors, the associated wiring harness and connectors, and the coupling system for charging the RESS

2-2 "RESS"

Rechargeable energy storage system that provides the electric energy for propulsion

2-3 Energy conversion system

system that generates and provides electric energy for propulsion.

2-4 Electronic converter

a device capable of controlling or converting electric power,

2-5 Coupling system for charging the RESS

the electrical circuit used for charging the RESS from an external electric power supply including the vehicle inlet

2-6 External electric power supply

an AC or DC electric power supply outside of the vehicle.

2-7 Passenger compartment

the space for occupant accommodation, bounded by the roof, floor, side walls, doors, window glass, front bulkhead and rear bulkhead, or rear gate, as well as by the barriers and enclosures provided for

protecting the power train from direct contact with live parts.

2-8 Luggage compartment

the space in the vehicle for luggage accommodation, bounded by the roof, hood, floor, side walls, as well as by the barrier and enclosure provided for protecting the power train from direct contact with live parts, being separated from the passenger compartment by the front bulkhead or the rear bulk head.

2-9 Direct contact

the contact of persons with live parts.

2-10 Live parts

conductive part(s) intended to be electrically energized in normal use.

2-11 Indirect contact

the contact of persons with exposed conductive parts.

2-12 Protection degree

Protection provided by a barrier/enclosure related to the contact with live parts by a test probe, such as a test finger (IPXXB) or a test wire (IPXXD), as defined in Attached Sheet 3

2-13 Exposed conductive part

conductive part which can be touched under the provisions of the protection degree IPXXB, and which only becomes electrically energized under failure conditions.

2-14 Electrical circuit

an assembly of connected live parts which is designed to be electrically energized in normal operation.

2-15 Working voltage

the highest value of an electrical circuit voltage, specified by the manufacturer, which may occur between any conductive parts in open circuit conditions or under normal operation condition.

2-16 Electrical chassis

a set made of conductive parts electrically linked together, whose potential is taken as reference.

2-17 Solid insulator

insulating coating of wiring harnesses provided in order to cover and protect the live parts against direct contact from any direction of access; covers for insulating the live parts of connectors; and varnish or paint for the purpose of insulation.

2-18 Barrier

the part providing protection against direct contact to the live parts from any direction of access.

2-19 Enclosure

the part enclosing the internal units and providing protection against direct contact from any usual direction of access.

2-20 Service plug

the device for shutting off the electrical circuit when conducting checks and services of the traction battery, fuel cell stack, etc.

2-21 On-board isolation resistance monitoring system

the device which monitors the isolation resistance between the high voltage buses and the electrical chassis.

2-22 High Voltage

classification of an electric component or circuit, if its maximum working voltage is $> 60 \text{ V}$ and $\leq [1500 \text{ V d.c.}]$ or $> 30 \text{ V}$ and $\leq [1000 \text{ V a.c.}]$ respectively

2-23 High Voltage Bus

electrical circuit, including the coupling system for charging the RESS, that operates on high voltage

3. Requirements

During and after the specified crash test(s), vehicles shall meet the performance requirements specified in paragraphs 3.1 through 3.3.

3.1. Electrolyte spillage from RESS

No liquid electrolyte shall leak into the passenger compartment; a limited leakage is permissible, however, only to outside the vehicle, provided that the leakage which occurs during the first hour after the test does not exceed 7 % of the total of the liquid electrolyte in the RESS.

3.2. RESS retention

The RESS shall remain fixed in their places.

3.3. Electrical Safety

After each crash test, at least one of the following criteria specified in paragraph 3.3.1 through paragraph 3.3.4 shall be met. If the vehicle has an automatic disconnect function, the criteria shall be applied to each divided portion individually.

3.3.1. Insulation Resistance

If the electrical circuit divided by the disconnect function includes AC circuit, this part of the high voltage bus shall be considered as an AC high voltage bus.

If the electrical circuit divided by the disconnect function doesn't include AC circuit, this part of the high voltage bus shall be considered as a DC high voltage bus.

3.3.1.1. For AC high voltage buses, insulation resistance between the high voltage bus and the electrical chassis shall have minimum value of 500 ohms/volt of working voltage.

If the protection degree IPXXB is satisfied for AC portion of the high voltage buses after crash, insulation resistance between the high voltage bus and the electrical chassis shall have minimum value of 100 ohms/volt of working voltage.

3.3.1.2. For DC high voltage buses, insulation resistance between any high voltage bus and the electrical chassis shall have minimum value of 100 ohms/volt of working voltage.

3.3.2. Voltage

3.3.2.1. For AC high voltage buses, voltage of the bus shall be equal to or less than 30 VAC.

3.3.2.2. For DC high voltage buses, voltage of the bus shall be equal to or less than 60 VDC.

3.3.3. Energy

Energy on the high voltage bus shall be less than 0.2 Joules.

3.3.4. Physical Protection

3.3.4.1. For protection of live parts, the protection degree IPXXB shall be provided.

3.3.4.2. For protection against indirect contact with live parts, all exposed electroconductive components shall be securely connected to the electrical chassis such that no dangerous potentials are produced. The resistance between the electrical chassis and all exposed electroconductive components shall be less than 0.1 ohm, which is measured when there is a current flow of at least 0.2 amps.

The said resistance shall be regarded as lower than 0.1 ohm when it is clearly evident that the DC electrical connection has been established adequately and securely by welding.

From this point below, no OICA discussion was done yet

4. Test Conditions

The test conditions specified in paragraphs 4.1 and 4.2 shall be used. Where a range is specified, the vehicle must be capable of meeting the requirements at all points within the range.

4.1. RESS state of charge

The RESS is at the level specified in the following paragraph (a), (b), or (c), as appropriate:

(a) At the maximum state of charge recommended by the manufacturer, as stated in the vehicle operator's manual or on a label that is permanently affixed to the vehicle;

(b) If the manufacturer has made no recommendation, at a state of charge of not less than 95 percent of the maximum capacity of the RESS; or

(c) If the RESS are rechargeable only by an energy source on the vehicle, at any state of charge within the normal operating voltage, as defined by the vehicle manufacturer.

4.2. Vehicle conditions

4.2.1. The high voltage system shall be connected to the vehicle propulsion system, and the vehicle ignition shall be in the 'on ready' (high voltage system and auxiliary system energized) position.

However, in the case that the engine combustion is required in order to make the high voltage system energized, the vehicle ignition may be in the 'on' (auxiliary system energized) position.

4.2.2. The vehicle conditions other than specified in 4.2.1 shall be in the crash test protocols of the contracting parties.

5. Test Procedures

This section describes test procedures that may be used to determine electrical voltage, insulation resistance and energy levels between the high voltage bus and the electrical chassis. Alternative test and analysis methods may also be used to demonstrate compliance to the electrical safety requirements of paragraph 3.3. For example, megohmmeter measurements are an appropriate alternative to the procedure described below for measuring insulation resistance. Well-established calculation methods also exist to determine electrical energy on high voltage buses.

The following procedures should be performed before and after each of the specified crash tests.

5.1. Test setup and equipment

If a high voltage disconnect function is used, measurements are taken both the RESS side or the energy conversion system side and the traction system side of the device performing the disconnect function.

However, if the high voltage disconnect is integral to the RESS or the energy conversion system and the high-voltage bus of the RESS or the energy conversion system is fully enclosed within a physical barrier or enclosure that maintains protection class IPXXB after crash test, measurements may be taken only downstream of the device performing the disconnect function.

The voltmeter used in this test shall measure DC values and have an internal resistance of at least 10 mega ohms.

5.2. Bus voltage

The following instructions may be used if voltage is measured.

Prior to the vehicle crash test measure and record the high voltage bus voltage (V_b) (see Figure 2). If V_b is high voltage, conduct the specified vehicle crash test. After the crash test, determine the high voltage bus voltages (V_b , V_1 , V_2) (see Figure 2). If the RESS has exposed conductive portions, measure the voltage V_3 between any exposed conductive portions of it and the electrical chassis.

The measurement shall be made immediately after 5 seconds of the vehicle coming to rest after each crash test.

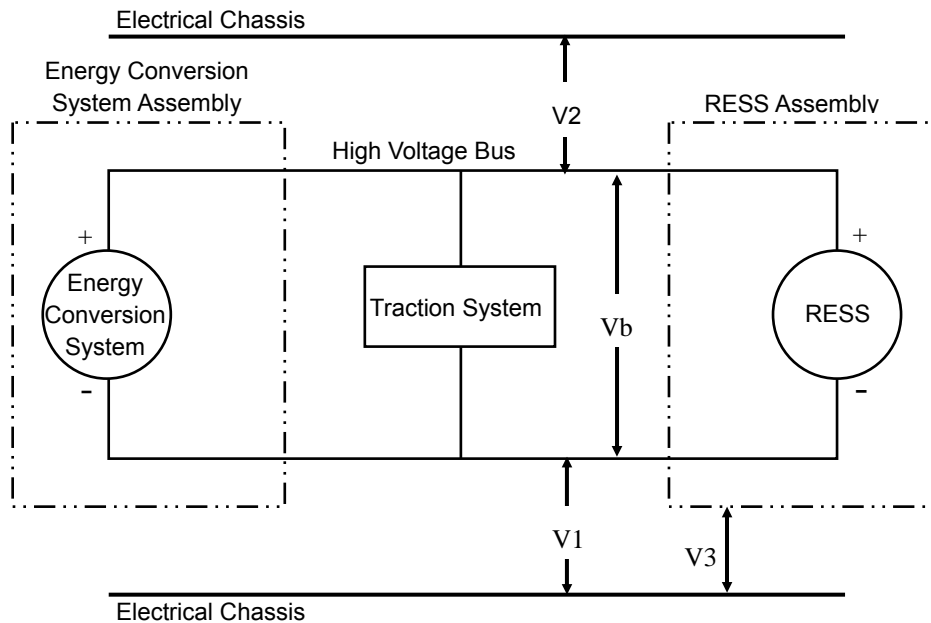

Figure 2: Measurement of V_b , V_1 , V_2

5.3. Insulation Resistance

The following instructions may be used if insulation resistance is measured.

Before the vehicle crash test, measure and record the high voltage bus voltage (V_b) (see Figure 2). V_b must be equal to or greater than the nominal operating voltage as defined by the vehicle manufacturer. It is acceptable for vehicle manufacturer to elect to calculate or simulate this value instead of measuring this after the crash.

Measure and record the voltage (V_1) between the negative side of the high voltage bus and the electrical chassis (see Figure 2):

Measure and record the voltage (V_2) between the positive side of the high voltage bus and the electrical chassis (see Figure 2):

If V_1 is greater than or equal to V_2 , insert a standard known resistance (R_o) between the negative side of the high voltage bus and the electrical chassis. With R_o installed, measure the voltage (V_1') between the negative side of the high voltage bus and the vehicle electrical chassis (see Figure 3). Calculate the insulation resistance (R_i) according to the formula shown. Divide this electrical isolation insulation resistance value (in ohms) by the working voltage of the high voltage bus (in volts).

$$R_i = R_o \cdot (V_b/V1' - V_b/V1) \quad \text{or} \quad R_i = R_o \cdot V_b \cdot (1/V1' - 1/V1)$$

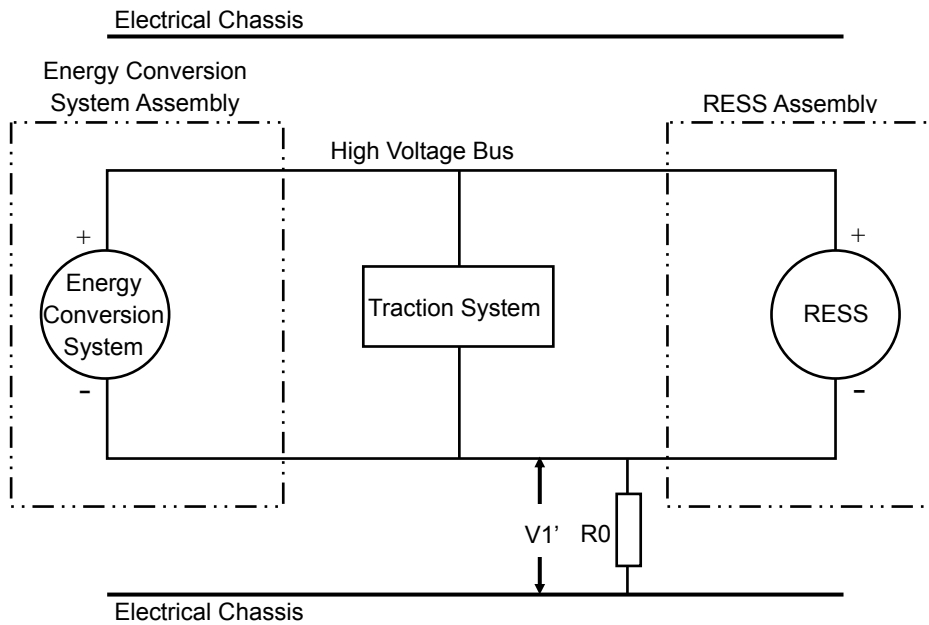

Figure 3: Measurement of V1'

If V2 is greater than V1, insert a standard known resistance (R_o) between the positive side of the high voltage bus and the electrical chassis. With R_o installed, measure the voltage (V2') between the positive side of the high voltage bus and the vehicle chassis. (See Figure 4.)

Calculate the insulation resistance (R_i) according to the formula shown. Divide this electrical isolation value (in ohms) by the working voltage of the high voltage bus (in volts).

$$R_i = R_o \cdot (V_b/V2' - V_b/V2) \quad \text{or} \quad R_i = R_o \cdot V_b \cdot (1/V2' - 1/V2)$$

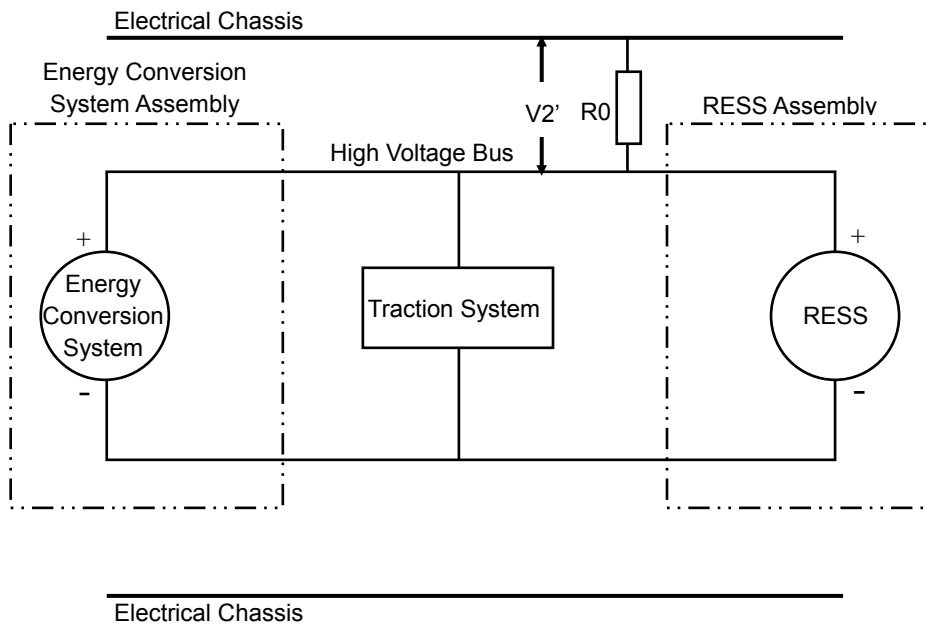

Figure 4: Measurement of V2'

NOTE 1: The standard known resistance R_o (in ohms) should be approximately 500 times the working voltage of the vehicle (in volts). R_o is not required to be precisely this value since the equations are valid for any R_o ; however, an R_o value in this range should provide good resolution for the voltage measurements.

5.4. Electrical Energy

The following procedure may be used if energy is measured.

After the vehicle crash determine the high voltage bus energy (see Figure 5). Install switch S1 and known resistance R_e . Close switch S1 and measure and record voltage V_b and current I_e . Integrate the product of these two measurements with respect to time to obtain total energy.

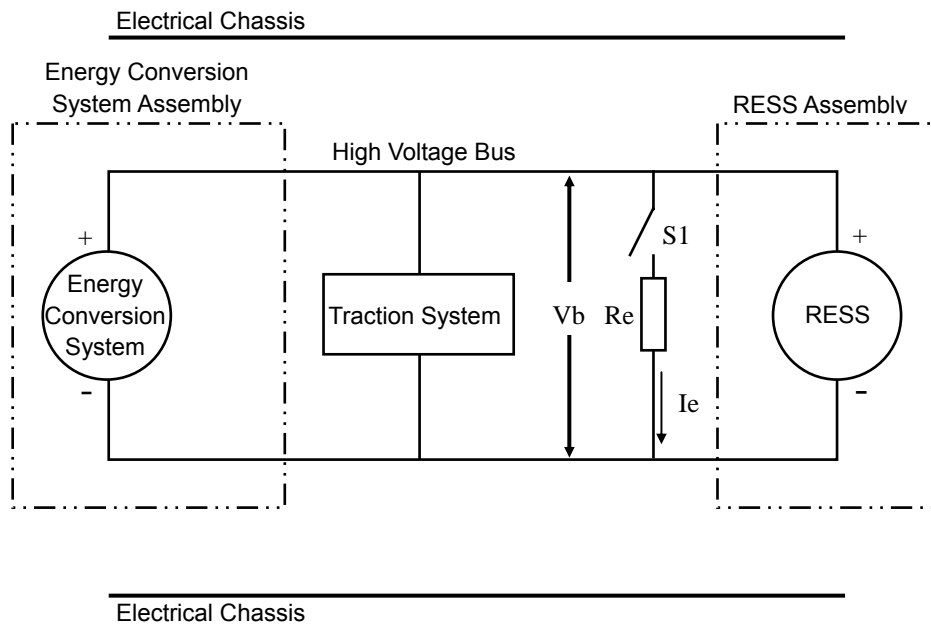

Figure 5: Measurement of high voltage bus energy

5.5. Physical Barrier

5.5.1. Test conditions

The manufacturer shall define the barrier, enclosure and solid insulator that protect the human from the direct contact to the high voltage bus in use. (hereinafter referred to as the 'original physical protection')

Any surrounding parts of the high voltage components that can be opened, disassembled or removed without the use of tools after crash test shall be opened, disassembled or removed. Surrounding parts that cannot be opened, disassembled or removed without the use of tools are considered as a part of the physical barrier.

The access probe is pushed against any openings of the physical barrier with the force specified in table 1. If it partly or fully penetrates into the original physical protection, it is placed in every possible position.

Starting from the straight position, both joints of the test finger shall be successively bent through an angle of up to 90 degree with respect to the axis of the adjoining section of the finger and shall

be placed in every possible position.

5.5.2. Acceptance conditions

The protection is satisfactory if adequate clearance is kept between the access probe and hazardous parts.

The access probe shall not touch hazardous live parts.

A mirror or a fiberscope may be used in order to inspect whether the access probe touches the high voltage buses, if necessary.