



**Economic and Social  
Council**

Distr.  
GENERAL

ECE/TRANS/WP.29/GRPE/2009/16  
1 April 2009

Original: ENGLISH  
ENGLISH AND FRENCH ONLY

---

**ECONOMIC COMMISSION FOR EUROPE**

INLAND TRANSPORT COMMITTEE

World Forum for Harmonization of Vehicle Regulations

Working Party on Pollution and Energy

Fifty-eighth session

Geneva, 9-12 June 2009

Item 5 of the provisional agenda

EXHAUST EMISSIONS TEST PROTOCOL OF NON-ROAD MOBILE MACHINERY  
(NRMM)

Proposal for draft global technical regulation concerning the test procedure for compression-ignition (C.I.) engines to be installed in agricultural and forestry tractors and in non-road mobile machinery with regard to the emissions of pollutants by the engine

Submitted by the expert from the European Commission<sup>1</sup>

The text reproduced below was prepared by the expert from the European Commission on behalf of the Working Party on Pollution and Energy (GRPE) working group on non-road mobile machinery engines (NRMM). It is mainly based on a document without a symbol (informal document No. GRPE-57-21), distributed during the fifty-seventh session of GRPE (see report ECE/TRANS/WP.29/GRPE/57, paras. 25 and 26).

---

<sup>1</sup> In accordance with the programme of work of the Inland Transport Committee for 2006-2010 (ECE/TRANS/166/Add.1, programme activity 02.4), the World Forum will develop, harmonize and update Regulations in order to enhance performance of vehicles. The present document is submitted in conformity with that mandate.

## A. STATEMENT OF TECHNICAL RATIONALE AND JUSTIFICATION

### 1. TECHNICAL AND ECONOMIC FEASIBILITY

1. The objective of this proposal is to establish a global technical regulation (gtr) for non-road mobile machinery (NRMM) compression-ignition (C.I.) engine emissions under the 1998 Global Agreement. The basis is the harmonized non-road test protocol, including test cycles, as developed by the NRMM informal group of the GRPE and also using the non-road transient test cycle (NRTC) developed between 2000 – 2002 by an international task force.

2. Some countries have already introduced regulations governing exhaust-emissions from non-road mobile machinery engines but the test procedures vary. To ensure the maximum benefit to the environment as well as the efficient use of energy, it is desirable that as many countries as possible use the same test protocol for emission control. Society will benefit from this harmonization of requirements through a general global reduction of the emission levels. Manufacturers of non-road mobile machinery are already operating in a world market and it is economically more efficient for them to develop engine models to meet internationally consistent emissions regulations. The harmonization achieved through this gtr enables manufacturers to develop new models most effectively. Finally, the consumer would benefit by having a choice of low emitting engines built to a globally recognized standard at a lower price.

3. New research into the world-wide pattern of real NRMM use was fed into the transient cycle development work which had been initiated by the United States Environmental Protection Agency (US-EPA) and developed in cooperation with the Joint Research Centre (JRC) of the European Commission and an international task force. From the collected data a transient test cycle with both cold and hot start requirements was developed. For hot start steady state test cycle the basis was offered by an expert committee of the International Organization for Standardization (ISO). The test cycles have been published in standard series ISO 8178. The procedure reflects exhaust emissions measurement technology with the potential to accurately measure the pollutant emissions from future low emission engines. The NRTC test cycle has been adopted in the European Union (EU), Canada and US emission legislation and it is the basis for the special vehicle legislation under development in Japan. This gtr intends to achieve a high level of harmonization of the complementary testing conditions among these existing or progressing legislations.

4. The test procedure reflects world-wide NRMM engine operation, as closely as possible, and provides a marked improvement in the realism of the test procedure for measuring the emission performance of existing and future NRMM engines. In summary, the test procedure was developed so that it would be:

- (a) representative of world-wide non-road mobile machinery engine operations,
- (b) able to provide the highest possible level of efficiency in controlling non-road mobile machinery engine emissions,
- (c) corresponding to state-of-the-art testing, sampling and measurement technology,
- (d) applicable in practice to existing and foreseeable future exhaust emissions abatement technologies, and
- (e) capable of providing a reliable ranking of exhaust emission levels from different engine types.

5. At this stage, the gtr is being presented without limit values and the NRMM engines' applicable power range. In this way, the test procedure can be given a legal status, based on which the Contracting Parties are required to start the process of implementing it into their national law. The gtr contains one option, the adoption of which is left to the discretion of the Contracting Parties. This option is related to the allowed dilution air temperature range.

6. When implementing the test procedure contained in this gtr as part of their national legislation or regulation, Contracting Parties are invited to use limit values which represent at least the same level of severity as their existing regulations, pending the development of harmonized limit values by the Executive Committee (AC.3) of the 1998 Agreement administered by the World Forum for Harmonization of Vehicle Regulations (WP.29). The performance levels (emissions test results) to be achieved in the gtr will, therefore, be discussed on the basis of the most recently agreed legislation in the Contracting Parties, as required by the 1998 Agreement.

7. In order to facilitate the regulatory activities of certain countries, in particular those that have not yet enforced legislation in this field or whose legislation is not yet as rigorous as the ones mentioned above, a guidance document is also available. The format is based on the one used in the EU for New and Global Approach Directives. It is important to note that only the text of the gtr is legally binding. The guidance document has no legal status as it does not introduce any additional requirements but aims at facilitating the use of the gtr and to help in applying the gtr. The guidance document is placed side by side with the gtr at the UNECE WP.29 website as already agreed by AC.3.

## 2. ANTICIPATED BENEFITS

8. NRMM and the relative engines are developed and produced for the world market. It is economically inefficient for manufacturers to have to prepare substantially different models in order to meet different emission regulations and methods of measuring emissions, which, in principle, aim at achieving the same objective. To enable manufacturers to develop new models more effectively and within a shorter time, it is desirable that a gtr should be developed. These savings will accrue not only to the manufacturer, but more importantly, to the consumer as well.

9. However, developing a test procedure just to address the economic question does not completely address the mandate given when work on this gtr was first started. The test procedure shall also improve the state of testing NRMM engines, and better reflect how NRMM engines are used today. As mentioned above some of the Contracting Parties already adopted legislation which includes the test cycles foreseen by this gtr. For Contracting Parties to the 1998 Agreement that have not yet enforced the same level of legislation, the testing methods defined in this gtr are much more representative of in-use operating behaviour of NRMM world-wide compared to the measurement methods defined in existing legislation.

10. As a consequence, it can be expected that the widespread application of this gtr for emissions legislation within the Contracting Parties to the 1998 Agreement will result in a tighter control of in-use emissions due to the improved correlation of the test methods with in-use operating behaviour of NRMM.

### 3. POTENTIAL COST EFFECTIVENESS

11. Specific cost effectiveness values for this gtr have not been calculated. The decision by AC.3 to move forward with the emission gtr without limit values is the key reason why this analysis has not been completed. However, this information will be available when in the later phase of this gtr development, harmonized limit values will be developed. Special attention will be given to the ongoing process to develop such performance requirements for the insertion into gtr No. 2 on Worldwide harmonized Motorcycle emission Test Cycle (WMTC). Experience will be also gained by the NRMM engines industry as to which cost and cost saving are associated with using this test procedure. The cost and emissions performance data can then be analyzed as part of the next step in this gtr development to determine the cost effectiveness values of the test procedure in this gtr. While there are no values on calculated costs per ton, experts believe there are clear benefits associated with this gtr.

B. TEXT OF REGULATION

1. PURPOSE

This regulation aims at providing a world-wide harmonized method for the determination of the levels of pollutant emissions from compression-ignition (C.I.) engines used in vehicles of category T and non-road mobile machinery in a manner which is representative of real world vehicle operation. The results can be the basis for the regulation of pollutant emissions within regional type-approval and certification procedures.

2. SCOPE

This regulation applies to the determination of the emissions of pollutants of compression-ignition (C.I.) engines with a maximum power not smaller than 19 kW and not larger than 560 kW to be used:

- (a) in category T vehicles 2/,
- (b) in non-road mobile machinery.

3. DEFINITIONS, SYMBOLS AND ABBREVIATIONS

3.1. Definitions

3.1.1. "Adjustment factors" mean additive (upward adjustment factor and downward adjustment factor) or multiplicative factors to be considered during the periodic (infrequent) regeneration;

3.1.2. "Applicable emission limit" means an emission limit to which an engine is subject;

3.1.3. "Aqueous condensation" means the precipitation of water-containing constituents from a gas phase to a liquid phase. Aqueous condensation is a function of humidity, pressure, temperature, and concentrations of other constituents such as sulphuric acid. These parameters vary as a function of engine intake-air humidity, dilution-air humidity, engine air-to-fuel ratio, and fuel composition - including the amount of hydrogen and sulphur in the fuel;

3.1.4. "Atmospheric pressure" means the wet, absolute, atmospheric static pressure. Note that if the atmospheric pressure is measured in a duct, negligible pressure losses shall be ensured between the atmosphere and the measurement location, and changes in the duct's static pressure resulting from the flow shall be accounted for;

3.1.5. "Calibration" means the process of setting a measurement system's response so that its output agrees with a range of reference signals. Contrast with "verification";

---

2/ As described in Annex 7 to the Consolidated Resolution on the Construction of Vehicles (R.E.3) (TRANS/WP.29/78/Rev.1/Amend. 2).

- 3.1.6. "Calibration gas" means a purified gas mixture used to calibrate gas analyzers. Calibration gases shall meet the specifications of 9.5.1. Note that calibration gases and span gases are qualitatively the same, but differ in terms of their primary function. Various performance verification checks for gas analyzers and sample handling components might refer to either calibration gases or span gases;
- 3.1.7. "Certification" means relating to the process of obtaining a certificate of conformity;
- 3.1.8. "Constant-speed engine" means an engine whose certification is limited to constant-speed operation. Engines whose constant-speed governor function is removed or disabled are no longer constant-speed engines;
- 3.1.9. "Constant-speed operation" means engine operation with a governor that automatically controls the operator demand to maintain engine speed, even under changing load. Governors do not always maintain speed exactly constant. Typically, speed can decrease (0.1 to 10) per cent below the speed at zero load, such that the minimum speed occurs near the engine's point of maximum power;
- 3.1.10. "Continuous regeneration" means the regeneration process of an exhaust after-treatment system that occurs either in a sustained manner or at least once over the applicable transient test cycle or ramped-modal cycle; in contrast to periodic (infrequent) regeneration;
- 3.1.11. "Conversion efficiency of non-methane cutter (NMC)  $E$ " means the efficiency of the conversion of a NMC that is used for the removal of the non-methane hydrocarbons from the sample gas by oxidizing all hydrocarbons except methane. Ideally, the conversion for methane is 0 per cent ( $E_{\text{CH}_4} = 0$ ) and for the other hydrocarbons represented by ethane is 100 per cent ( $E_{\text{C}_2\text{H}_6} = 100$  per cent). For the accurate measurement of NMHC, the two efficiencies shall be determined and used for the calculation of the NMHC emission mass flow rate for methane and ethane. Contrast with "penetration fraction";
- 3.1.12. "Delay time" means the difference in time between the change of the component to be measured at the reference point and a system response of 10 per cent of the final reading ( $t_{10}$ ) with the sampling probe being defined as the reference point. For the gaseous components, this is the transport time of the measured component from the sampling probe to the detector (see figure 3.1);
- 3.1.13. "deNO<sub>x</sub> system" means an exhaust after-treatment system designed to reduce emissions of oxides of nitrogen (NO<sub>x</sub>) (e.g. passive and active lean NO<sub>x</sub> catalysts, NO<sub>x</sub> adsorbers and selective catalytic reduction (SCR) systems);
- 3.1.14. "Dew point" means a measure of humidity stated as the equilibrium temperature at which water condenses under a given pressure from moist air with a given absolute humidity. Dew point is specified as a temperature in °C or K, and is valid only for the pressure at which it is measured;

- 3.1.15. "Discrete-mode" means relating to a discrete-mode type of steady-state test, as described in paragraph 7.4.1.1. and Annex A.1;
- 3.1.16. "Drift" means the difference between a zero or calibration signal and the respective value reported by a measurement instrument immediately after it was used in an emission test, as long as the instrument was zeroed and spanned just before the test;
- 3.1.17. "Electronic control unit" means an engine's electronic device that uses data from engine sensors to control engine parameters;
- 3.1.18. "Emission-control system" means any device, system, or element of design that controls or reduces the emissions of regulated pollutants from an engine;
- 3.1.19. "Engine family" means a manufacturer's grouping of engines which, through their design as defined in paragraph 5.2. of this regulation, have similar exhaust emission characteristics; all members of the family shall comply with the applicable emission limit values;
- 3.1.20. "Engine governed speed" means the engine operating speed when it is controlled by the installed governor;
- 3.1.21. "Engine system" means the engine, the emission control system and the communication interface (hardware and messages) between the engine system electronic control unit(s) (ECU) and any other powertrain or vehicle control unit;
- 3.1.22. "Engine type" means a category of engines which do not differ in essential engine characteristics;
- 3.1.23. "Exhaust after-treatment system" means a catalyst, particulate filter, deNO<sub>x</sub> system, combined deNO<sub>x</sub> particulate filter or any other emission-reducing device that is installed downstream of the engine. This definition excludes exhaust gas recirculation (EGR) and turbochargers, which are considered an integral part of the engine;
- 3.1.24. "Exhaust-gas recirculation" means a technology that reduces emissions by routing exhaust gases that had been exhausted from the combustion chamber(s) back into the engine to be mixed with incoming air before or during combustion. The use of valve timing to increase the amount of residual exhaust gas in the combustion chamber(s) that is mixed with incoming air before or during combustion is not considered exhaust-gas recirculation for the purposes of this regulation;
- 3.1.25. "Full flow dilution method" means the process of mixing the total exhaust flow with dilution air prior to separating a fraction of the diluted exhaust stream for analysis;

- 3.1.26. "Gaseous pollutants" means carbon monoxide, hydrocarbons and/or non-methane hydrocarbons (assuming a ratio of  $\text{CH}_{1.85}$  for diesel), methane and oxides of nitrogen (expressed as nitrogen dioxide ( $\text{NO}_2$ ) equivalent);
- 3.1.27. "Good engineering judgment" means judgments made consistent with generally accepted scientific and engineering principles and available relevant information;
- 3.1.28. "HEPA filter" means high-efficiency particulate air filters that are rated to achieve a minimum initial particle-removal efficiency of 99.97 per cent using ASTM F 1471–93 or equivalent standard;
- 3.1.29. "Hydrocarbon (HC)" means THC, NMHC as applicable. Hydrocarbon generally means the hydrocarbon group on which the emission standards are based for each type of fuel and engine;
- 3.1.30. "High speed ( $n_{hi}$ )" means the highest engine speed where 70 per cent of the maximum power occurs;
- 3.1.31. "Idle speed" means the lowest engine speed with minimum load (greater than or equal to zero load), where an engine governor function controls engine speed. For engines without a governor function that controls idle speed, idle speed means the manufacturer-declared value for lowest engine speed possible with minimum load. Note that warm idle speed is the idle speed of a warmed-up engine;
- 3.1.32. "Intermediate test speed" means that engine speed which meets one of the following requirements:
- (a) for engines which are designed to operate over a speed range on a full load torque curve, the intermediate speed shall be the declared maximum torque speed if it occurs between 60 per cent and 75 per cent of rated speed,
  - (b) if the declared maximum torque speed is less than 60 per cent of rated speed, then the intermediate speed shall be 60 per cent of the rated speed,
  - (c) if the declared maximum torque speed is greater than 75 per cent of the rated speed then the intermediate speed shall be 75 per cent of rated speed;
- 3.1.33. "Linearity" means the degree to which measured values agree with respective reference values. Linearity is quantified using a linear regression of pairs of measured values and reference values over a range of values expected or observed during testing;
- 3.1.34. "Low speed ( $n_{lo}$ )" means the lowest engine speed where 50 per cent of the maximum power occurs;
- 3.1.35. "Maximum power ( $P_{max}$ )" means the maximum power in kW as designed by the manufacturer;
- 3.1.36. "Maximum torque speed" means the engine speed at which the maximum torque is obtained from the engine, as designed by the manufacturer;



- 3.1.37. "Means of a quantity" based upon flow-weighted mean values means the mean level of a quantity after it is weighted proportionally to the corresponding flow rate;
- 3.1.38. "Non-methane hydrocarbons (NMHC)" means the sum of all hydrocarbon species except methane;
- 3.1.39. "Open crankcase emissions" means any flow from an engine's crankcase that is emitted directly into the environment;
- 3.1.40. "Operator demand" means an engine operator's input to control engine output. The "operator" may be a person (i.e., manual), or a governor (i.e., automatic) that mechanically or electronically signals an input that demands engine output. Input may be from an accelerator pedal or signal, a throttle-control lever or signal, a fuel lever or signal, a speed lever or signal, or a governor setpoint or signal;
- 3.1.41. "Oxides of nitrogen" means compounds containing only nitrogen and oxygen as measured by the procedures specified in this regulation. Oxides of nitrogen are expressed quantitatively as if the NO is in the form of NO<sub>2</sub>, such that an effective molar mass is used for all oxides of nitrogen equivalent to that of NO<sub>2</sub>;
- 3.1.42. "Parent engine" means an engine selected from an engine family in such a way that its emissions characteristics are representative for that engine family, see paragraph 5.2.4.;
- 3.1.43. "Partial pressure" means the pressure,  $p$ , attributable to a single gas in a gas mixture. For an ideal gas, the partial pressure divided by the total pressure is equal to the constituent's molar concentration,  $x$ ;
- 3.1.44. "Particulate after-treatment device" means an exhaust after-treatment system designed to reduce emissions of particulate pollutants (PM) through a mechanical, aerodynamic, diffusional or inertial separation;
- 3.1.45. "Partial flow dilution method" means the process of separating a part from the total exhaust flow, then mixing it with an appropriate amount of dilution air prior to the particulate sampling filter;
- 3.1.46. "Particulate matter (PM)" means any material collected on a specified filter medium after diluting exhaust with clean filtered air to a temperature and a point as specified in paragraph 9.3.3.4.; this is primarily carbon, condensed hydrocarbons, and sulphates with associated water;
- 3.1.47. "Penetration fraction  $PF$ " means the deviation from ideal functioning of a non-methane cutter (see Conversion efficiency of non-methane cutter (NMC)  $E$ ). An ideal non-methane cutter would have a methane penetration factor,  $PF_{CH_4}$ , of 1.000 (that is, a methane conversion efficiency  $E_{CH_4}$  of 0), and the penetration fraction for all other hydrocarbons would be 0.000, as represented by  $PF_{C_2H_6}$  (that is, an ethane

- conversion efficiency  $E_{C_2H_6}$  of 1). The relationship is:  $PF_{CH_4} = 1 - E_{CH_4}$  and  $PF_{C_2H_6} = 1 - E_E$ ;
- 3.1.48. "Per cent load" means the fraction of the maximum available torque at an engine speed;
- 3.1.49. "Periodic (or infrequent) regeneration" means the regeneration process of an exhaust after-treatment system that occurs periodically in typically less than 100 hours of normal engine operation. During cycles where regeneration occurs, emission standards may be exceeded;
- 3.1.50. "Probe" means the first section of the transfer line which transfers the sample to next component in the sampling system;
- 3.1.51. "PTFE means polytetrafluoroethylene, commonly known as Teflon™;
- 3.1.52. "Ramped modal steady state test cycle" means a test cycle with a sequence of steady state engine test modes with defined speed and torque criteria at each mode and defined speed and torque ramps between these modes;
- 3.1.53. "Rated speed" means the maximum full load speed allowed by the governor, as designed by the manufacturer, or, if such a governor is not present, the speed at which the maximum power is obtained from the engine, as designed by the manufacturer;
- 3.1.54. "Regeneration" means an event during which emissions levels change while the aftertreatment performance is being restored by design. Two types of regeneration can occur: continuous regeneration (see paragraph 6.6.1.) and infrequent (periodic) regeneration (see paragraph 6.6.2.);
- 3.1.55. "Response time" means the difference in time between the change of the component to be measured at the reference point and a system response of 90 per cent of the final reading ( $t_{90}$ ) with the sampling probe being defined as the reference point, whereby the change of the measured component is at least 60 per cent full scale (FS) and takes place in less than 0.1 second. The system response time consists of the delay time to the system and of the rise time of the system;
- 3.1.56. "Rise time" means the difference in time the 10 per cent and 90 per cent response of the final reading ( $t_{90} - t_{10}$ );
- 3.1.57. "Shared atmospheric pressure meter" means an atmospheric pressure meter whose output is used as the atmospheric pressure for an entire test facility that has more than one dynamometer test cell;
- 3.1.58. "Shared humidity measurement" means a humidity measurement that is used as the humidity for an entire test facility that has more than one dynamometer test cell;

- 3.1.59. "Span" means to adjust an instrument so that it gives a proper response to a calibration standard that represents between 75 per cent and 100 per cent of the maximum value in the instrument range or expected range of use;
- 3.1.60. "Span gas" means a purified gas mixture used to span gas analyzers. Span gases shall meet the specifications of paragraph 9.5.1. Note that calibration gases and span gases are qualitatively the same, but differ in terms of their primary function. Various performance verification checks for gas analyzers and sample handling components might refer to either calibration gases or span gases;
- 3.1.61. "Specific emissions" means the mass emissions expressed in g/kWh;
- 3.1.62. "Standalone" means something that has no dependencies; it can "stand alone";
- 3.1.63. "Steady-state" means relating to emission tests in which engine speed and load are held at a finite set of nominally constant values. Steady-state tests are either discrete-mode tests or ramped-modal tests;
- 3.1.64. "Stoichiometric" means relating to the particular ratio of air and fuel such that if the fuel were fully oxidized, there would be no remaining fuel or oxygen;
- 3.1.65. "Storage medium" means a particulate filter, sample bag, or any other storage device used for batch sampling;
- 3.1.66. "Test (or duty) cycle" means a sequence of test points each with a defined speed and torque to be followed by the engine under steady state or transient operating conditions. Duty cycles are specified in the Annex A.1. A single duty cycle may consist of one or more test intervals;
- 3.1.67. "Test interval" means a duration of time over which brake-specific emissions are determined. In cases where multiple test intervals occur over a duty cycle, the regulation may specify additional calculations that weigh and combine results to arrive at composite values for comparison against the applicable emission limits;
- 3.1.68. "Tolerance" means the interval in which 95 per cent of a set of recorded values of a certain quantity shall lie, with the remaining 5 per cent of the recorded values deviating from the tolerance interval only due to measurement variability. The specified recording frequencies and time intervals shall be used to determine if a quantity is within the applicable tolerance. For parameters not subject to measurement variability, tolerance means an absolute allowable range;
- 3.1.69. "Total hydrocarbon (THC)" means the combined mass of organic compounds measured by the specified procedure for measuring total hydrocarbon, expressed as a hydrocarbon with a hydrogen-to-carbon mass ratio of 1.85:1;
- 3.1.70. "Transformation time" means the difference in time between the change of the component to be measured at the reference point and a system response of 50 per

cent of the final reading ( $t_{50}$ ) with the sampling probe being defined as the reference point. The transformation time is used for the signal alignment of different measurement instruments. See figure 3.1;

- 3.1.71. "Transient test cycle" means a test cycle with a sequence of normalized speed and torque values that vary relatively quickly with time (NRTC);
- 3.1.72. "Type approval" means the approval of an engine type with regard to its emissions measured in accordance with the procedures specified in this regulation;
- 3.1.73. "Updating-recording" means the frequency at which the analyser provides new, current, values;
- 3.1.74. "Useful life" means the relevant period of distance and/or time over which compliance with the relevant gaseous and particulate emission limits has to be assured;
- 3.1.75. "Variable-speed engine" means an engine that is not a constant-speed engine;
- 3.1.76. "Verification" means to evaluate whether or not a measurement system's outputs agree with a range of applied reference signals to within one or more predetermined thresholds for acceptance. Contrast with "calibration";
- 3.1.77. "To zero" means to adjust an instrument so it gives a zero response to a zero calibration standard, such as purified nitrogen or purified air for measuring concentrations of emission constituents;
- 3.1.78. "Zero gas" means a gas that yields a zero response in an analyzer. This may either be purified nitrogen, purified air, a combination of purified air and purified nitrogen.

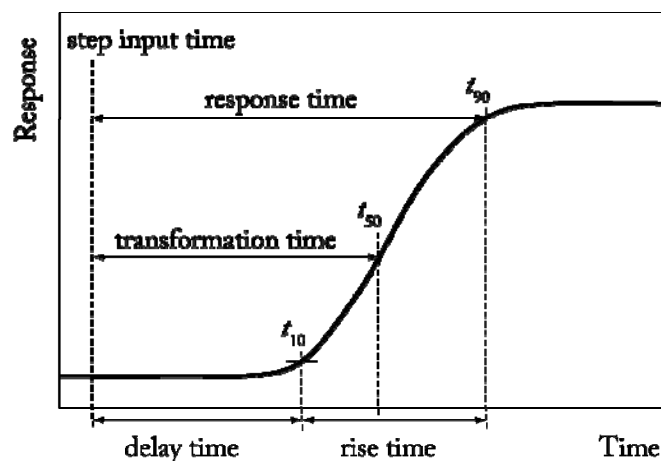

Figure 3.1: Definitions of system response: delay time (3.1.12.), response time (3.1.55.), rise time (3.1.56.) and transformation time (3.1.70.)

3.2. General symbols 3/

Symbol	Unit	Term
$a_0$	-	$y$ intercept of the regression line
$a_1$	-	Slope of the regression line
$\alpha_{sp}$	rad/s <sup>2</sup>	Derivative of the engine speed at the set point
$A/F_{st}$	-	Stoichiometric air to fuel ratio
$c$	ppm, per cent vol	Concentration (also in $\mu\text{mol}/\text{mol} = \text{ppm}$ )
$D$	-	Dilution factor
$d$	m	Diameter
$E$	per cent	Conversion efficiency
$e$	g/kWh	Brake specific basis
$e_{\text{gas}}$	g/kWh	Specific emission of gaseous components
$e_{\text{PM}}$	g/kWh	Specific emission of particulates
$e_w$	g/kWh	Weighted specific emission
$F$		F-test statistics
$F$	-	Frequency of the regeneration event in terms of fraction of tests during which the regeneration occurs
$f_a$	-	Laboratory atmospheric factor
$\theta_D$	kg·mm <sup>2</sup>	Rotational inertia of the eddy current dynamometer D
$k_r$	-	Multiplicative regeneration factor
$k_{Dr}$	-	downward adjustment factor
$k_{Ur}$	-	upward adjustment factor
$\lambda$	-	Excess air ratio
$L$	-	Per cent torque
$M_a$	g/mol	Molar mass of the intake air
$M_e$	g/mol	Molar mass of the exhaust
$M_{\text{gas}}$	g/mol	Molar mass of gaseous components
$m$	kg	Mass
$m_{\text{gas}}$	g	Mass of gaseous emissions over the test cycle
$m_{\text{PM}}$	g	Mass of particulate emissions over the test cycle
$n$	min <sup>-1</sup>	Engine rotational speed
$n_{hi}$	min <sup>-1</sup>	High engine speed
$n_{lo}$	min <sup>-1</sup>	Low engine speed
$P$	kW	Power
$P_{\text{max}}$	kW	Maximum observed or declared power at the test speed under the test conditions (specified by the manufacturer)
$P_{\text{AUX}}$	kW	Declared total power absorbed by auxiliaries fitted for the test
$p$	kPa	Pressure
$p_a$	kPa	Dry atmospheric pressure
$PF$	per cent	Penetration fraction

---

3/ Specific symbols are found in Annexes

Symbol	Unit	Term
$q_{maw}$	kg/s	Intake air mass flow rate on wet basis
$q_{mdw}$	kg/s	Dilution air mass flow rate on wet basis
$q_{mdew}$	kg/s	Diluted exhaust gas mass flow rate on wet basis
$q_{mew}$	kg/s	Exhaust gas mass flow rate on wet basis
$q_{mf}$	kg/s	Fuel mass flow rate
$q_{mp}$	kg/s	Sample flow of exhaust gas into partial flow dilution system
$q_V$	m <sup>3</sup> /s	Volume flow rate
$r_d$	-	Dilution ratio
$r^2$	-	Coefficient of determination
$\rho$	kg/m <sup>3</sup>	Density
$\sigma$	-	Standard deviation
$S$	kW	Dynamometer setting
$SEE$	-	Standard error of estimate of $y$ on $x$
$T$	°C	Temperature
$T_a$	K	Absolute temperature
$T$	N·m	Engine torque
$T_{sp}$	N·m	Demanded torque with "sp" set point
$u$	-	Ratio between densities of gas component and exhaust gas
$t$	s	Time
$\Delta t$	s	Time interval
$t_{10}$	s	Time between step input and 10 per cent of final reading
$t_{50}$	s	Time between step input and 50 per cent of final reading
$t_{90}$	s	Time between step input and 90 per cent of final reading
$V$	m <sup>3</sup>	Volume
$W$	kWh	Work
$y$		Generic variable
$\bar{y}$		Arithmetic mean

### 3.3. Subscripts

abs	Absolute quantity
act	Actual quantity
air	Air quantity
amb	Ambient quantity
atm	Atmospheric quantity
cor	Corrected quantity
CFV	Critical flow venturi
denorm	Denormalised engine speed
dry	Dry quantity
exp	Expected quantity
filter	PM sample filter
$i$	Instantaneous measurement (e.g. 1 Hz)
$i$	An individual of a series

idle	Condition at idle
in	Quantity in
leak	Leak quantity
max	Maximum (peak) value
meas	Measured quantity
min	Minimum value
mix	Molar mass of air
out	Quantity out
PDP	Positive displacement pump
ref	Reference quantity
SSV	Subsonic venturi
total	Total quantity
uncor	Uncorrected quantity
vac	Vacuum quantity
weight	Calibration weight
wet	Wet quantity

3.4. Symbols and abbreviations for the chemical components (used also as a subscript)

Ar	Argon
C <sub>1</sub>	Carbon 1 equivalent hydrocarbon
CH <sub>4</sub>	Methane
C <sub>2</sub> H <sub>6</sub>	Ethane
C <sub>3</sub> H <sub>8</sub>	Propane
CO	Carbon monoxide
CO <sub>2</sub>	Carbon dioxide
DOP	Di-octylphthalate
H	Atomic hydrogen
H <sub>2</sub>	Molecular hydrogen
HC	Hydrocarbon
H <sub>2</sub> O	Water
He	Helium
N <sub>2</sub>	Molecular nitrogen
NMHC	Non-methane hydrocarbon
NO <sub>x</sub>	Oxides of nitrogen
NO	Nitric oxide
NO <sub>2</sub>	Nitrogen dioxide
PM	Particulate matter
S	Sulphur
THC	Total hydrocarbon

3.5. Abbreviations

ASTM	American Society for Testing and Materials
BMD	Bag mini-diluter
BSFC	Brake-specific fuel consumption
CFV	Critical Flow Venturi
CI	Compression-ignition
CLD	Chemiluminescent Detector
CVS	Constant Volume Sampler
deNO <sub>x</sub>	NO <sub>x</sub> after-treatment system
DF	Deterioration factor
ECM	Electronic control module
EFC	Electronic flow control
EGR	Exhaust gas recirculation
FID	Flame Ionization Detector
GC	Gas Chromatograph
HCLD	Heated Chemiluminescent Detector
HFID	Heated Flame Ionization Detector
IBP	Initial boiling point
ISO	International Organization for Standardization
LPG	Liquefied Petroleum Gas
NDIR	Nondispersive infrared (Analyzer)
NDUV	Nondispersive ultraviolet (Analyzer)
NIST	US National Institute for Standards and Technology
NMC	Non-Methane Cutter
PDP	Positive Displacement Pump
Per cent FS	Per cent of full scale
PFD	Partial Flow Dilution
PFS	Partial Flow System
PTFE	Polytetrafluoroethylene (commonly known as Teflon™)
RMC	Ramped-modal cycle
RMS	Root-mean square
RTD	Resistive temperature detector
SAE	Society of Automotive Engineers
SSV	Subsonic Venturi
UCL	Upper confidence limit
UFM	Ultrasonic flow meter



#### 4. GENERAL REQUIREMENTS

The engine system shall be designed, constructed and assembled so as to enable it to comply with the provisions of this gtr. The technical measures taken by the manufacturer shall be such as to ensure that the mentioned emissions are effectively limited, pursuant to this gtr, throughout the useful life of the engine, as defined by the Contracting Party, and under normal conditions of use. For this, engines shall meet the performance requirements of paragraph 5., when tested in accordance with the test conditions of paragraph 6. and the test procedure of paragraph 7.

#### 5. PERFORMANCE REQUIREMENTS

##### 5.1. General requirements

##### 5.1.1. Implementation of test procedure

When implementing the test procedure contained in this gtr as part of their national legislation, Contracting Parties to the 1998 Agreement are invited to use limit values which represent at least the same level of severity as their existing regulations; pending the development of harmonized limit values, by the Executive Committee (AC.3) of the 1998 Agreement, for inclusion in the gtr at a later date.

##### 5.1.2. Emissions of gaseous and particulate pollutants

The pollutants are represented by:

- (a) Oxides of nitrogen, NO<sub>x</sub>.
- (b) Hydrocarbons, which may be expressed in the following ways:
  - (i) Total hydrocarbons, HC or THC,
  - (ii) Non-methane hydrocarbons, NMHC.
- (c) Particulate matter, PM.
- (d) Carbon monoxide, CO.

The measured values of gaseous and particulate pollutants exhausted by the engine refer to the brake-specific emissions in grams per kilowatt-hour (g/kWh). Other system of units may be used with appropriate conversion.

The emissions shall be determined on the duty cycles (steady-state and/or transient), as described in paragraph 7. The measurement systems shall meet the calibration and performance checks of paragraph 8. with measurement equipment of paragraph 9.

Other systems or analyzers may be approved by the type approval or certification authority if it is found that they yield equivalent results in accordance with paragraph 5.1.3.

### 5.1.3. Equivalency

The determination of system equivalency shall be based on a seven-sample pair (or larger) correlation study between the system under consideration and one of the systems of this gtr.

"Results" refer to the specific cycle weighted emissions value. The correlation testing is to be performed at the same laboratory, test cell, and on the same engine, and is preferred to be run concurrently. The equivalency of the sample pair averages shall be determined by *F*-test and *t*-test statistics as described in Annex A.2. obtained under the laboratory test cell and the engine conditions described above. Outliers shall be determined in accordance with ISO 5725 and excluded from the database. The systems to be used for correlation testing shall be subject to the approval by the type approval or certification authority.

## 5.2. Engine family

### 5.2.1. General

An engine family is characterized by design parameters. These shall be common to all engines within the family. The engine manufacturer may decide, which engines belong to an engine family, as long as the membership criteria listed in paragraph 5.2.3. are respected. The engine family shall be approved by the type approval or certification authority. The manufacturer shall provide to the type approval or certification authority the appropriate information relating to the emission levels of the members of the engine family. For purposes of certification or type approval, the Contracting Party may have additional requirements for engine family definition based upon engine power, fuel type and emission limits.

### 5.2.2. Special cases

#### 5.2.2.1. Interactions between parameters

In some cases there may be interaction between parameters, which may cause emissions to change. This shall be taken into consideration to ensure that only engines with similar exhaust emission characteristics are included within the same engine family. These cases shall be identified by the manufacturer and notified to the type approval or certification authority. It shall then be taken into account as a criterion for creating a new engine family.

#### 5.2.2.2. Devices or features having a strong influence on emissions

In case of devices or features, which are not listed in paragraph 5.2.3. and which have a strong influence on the level of emissions, this equipment shall be identified by the manufacturer using good engineering judgment, and shall be notified to the type approval or certification authority. It shall then be taken into account as a criterion for creating a new engine family.

5.2.2.3. Additional criteria

In addition to the parameters listed in paragraph 5.2.3., the manufacturer may introduce additional criteria allowing the definition of families of more restricted size. These parameters are not necessarily parameters that have an influence on the level of emissions.

5.2.3. Parameters defining the engine family

5.2.3.1. Combustion cycle

- (a) 2-stroke cycle
- (b) 4-stroke cycle
- (c) Rotary engine
- (d) Others

5.2.3.2. Configuration of the cylinders

5.2.3.2.1. Position of the cylinders in the block

- (a) V
- (b) In-line
- (c) Radial
- (d) Others (F, W, etc.)

5.2.3.2.2. Relative position of the cylinders

Engines with the same block may belong to the same family as long as their bore centre-to-centre dimensions are the same.

5.2.3.3. Main cooling medium

- (a) air
- (b) water
- (c) oil

5.2.3.4. Individual cylinder displacement

Within 85 per cent and 100 per cent for engines with a unit cylinder displacement  $\geq 0.75 \text{ dm}^3$  of the largest displacement within the engine family.

Within 70 per cent and 100 per cent for engines with a unit cylinder displacement  $< 0.75 \text{ dm}^3$  of the largest displacement within the engine family.

5.2.3.5. Method of air aspiration

- (a) naturally aspirated
- (b) pressure charged
- (c) pressure charged with charge cooler

- 5.2.3.6. Combustion chamber type/design
  - (a) Open chamber
  - (b) Divided chamber
  - (c) Other types
  
- 5.2.3.7. Valves and porting
  - (a) Configuration
  - (b) Number of valves per cylinder
  
- 5.2.3.8. Fuel supply type
  - (a) Pump, (high pressure) line and injector
  - (b) In-line pump or distributor pump
  - (c) Unit injector
  - (d) Common rail
  
- 5.2.3.9. Miscellaneous devices
  - (a) Exhaust gas recirculation (EGR)
  - (b) Water injection
  - (c) Air injection
  - (d) Others
  
- 5.2.3.10. Electronic control strategy

The presence or absence of an electronic control unit (ECU) on the engine is regarded as a basic parameter of the family.

In the case of electronically controlled engines, the manufacturer shall present the technical elements explaining the grouping of these engines in the same family, i.e. the reasons why these engines can be expected to satisfy the same emission requirements.

The electronic governing of speed does not need to be in a different family from those with mechanical governing. The need to separate electronic engines from mechanical engines should only apply to the fuel injection characteristics, such as timing, pressure, rate shape, etc.

- 5.2.3.11. Exhaust after-treatment systems

The function and combination of the following devices are regarded as membership criteria for an engine family:

- (a) Oxidation catalyst
- (b) DeNO<sub>x</sub> system with selective reduction of NO<sub>x</sub> (addition of reducing agent)
- (c) Other DeNO<sub>x</sub> systems
- (d) Particulate trap with passive regeneration
- (e) Particulate trap with active regeneration
- (f) Other particulate traps
- (g) Other devices

When an engine has been certified without after-treatment system, whether as parent engine or as member of the family, then this engine, when equipped with an oxidation catalyst (not with particulate trap), may be included in the same engine family, if it does not require different fuel characteristics.

If it requires specific fuel characteristics (e.g. particulate traps requiring special additives in the fuel to ensure the regeneration process), the decision to include it in the same family shall be based on technical elements provided by the manufacturer. These elements shall indicate that the expected emission level of the equipped engine complies with the same limit value as the non-equipped engine.

When an engine has been certified with after-treatment system, whether as parent engine or as member of a family, whose parent engine is equipped with the same after-treatment system, then this engine, when equipped without after-treatment system, shall not be added to the same engine family.

#### 5.2.4. Choice of the parent engine

Once the engine family has been agreed by the type approval or certification authority, the parent engine of the family shall be selected using the primary criterion of the highest fuel delivery per stroke at the declared maximum torque speed. In the event that two or more engines share this primary criterion, the parent engine shall be selected using the secondary criterion of highest fuel delivery per stroke at rated speed.

The type approval or certification authority may conclude that the worst-case emission rate of the family can best be characterized by testing additional engines. In this case, the parties involved shall have the appropriate information to determine the engines within the family likely to have the highest emissions level.

If engines within the family incorporate other variable features which may be considered to affect exhaust emissions, these features shall also be identified and taken into account in the selection of the parent engine.

If engines within the family meet the same emission values over different useful life periods, this shall be taken into account in the selection of the parent engine.

#### 5.3. Record keeping

Record keeping requirements to be decided by the Contracting Parties. The procedures in this gtr include various requirements to record data or other information.

## 6. TEST CONDITIONS

### 6.1. Laboratory test conditions

The absolute temperature ( $T_a$ ) of the engine air at the inlet to the engine expressed in Kelvin, and the dry atmospheric pressure ( $p_s$ ), expressed in kPa shall be measured and the parameter  $f_a$  shall be determined according to the following provisions. In multi-cylinder engines having distinct groups of intake manifolds, such as in a "V" engine configuration, the average temperature of the distinct groups shall be taken. The parameter  $f_a$  shall be reported with the test results. For better repeatability and reproducibility of the test results, it is recommended that the parameter  $f_a$  be such that:  $0.93 \leq f_a \leq 1.07$ . Contracting Parties can make the parameter  $f_a$  compulsory.

Naturally aspirated and mechanically supercharged engines:

$$f_a = \left(\frac{99}{p_s}\right) \times \left(\frac{T_a}{298}\right)^{0.7} \quad (6-1)$$

Turbocharged engines with or without cooling of the intake air:

$$f_a = \left(\frac{99}{p_s}\right)^{0.7} \times \left(\frac{T_a}{298}\right)^{1.5} \quad (6-2)$$

The temperature of intake air shall be maintained to  $(25 \pm 5)$  °C, as measured upstream of any engine component.

It is allowed to use:

- (a) a shared atmospheric pressure meter as long as the equipment for handling intake air maintains ambient pressure, where the engine is tested, within  $\pm 1$  kPa of the shared atmospheric pressure;
- (b) a shared humidity measurement for intake air as long as the equipment for handling intake air maintains dew point, where the engine is tested, within  $\pm 0.5$  °C of the shared humidity measurement.

### 6.2. Engines with charge air cooling

- (a) A charge-air cooling system with a total intake-air capacity that represents production engines' in-use installation shall be used. Any laboratory charge-air cooling system to minimize accumulation of condensate shall be designed. Any accumulated condensate shall be drained and all drains shall be completely closed before emission testing. The drains shall be kept closed during the emission test. Coolant conditions shall be maintained as follows:
  - (i) A coolant temperature of at least 20 °C shall be maintained at the inlet to the charge-air cooler throughout testing.
  - (ii) At the engine conditions specified by the manufacturer, the coolant flow rate shall be set to achieve an air temperature within  $\pm 5$  °C of the value

designed by the manufacturer after the charge-air cooler's outlet. The air-outlet temperature shall be measured at the location specified by the manufacturer. This coolant flow rate set point shall be used throughout testing. If the engine manufacturer does not specify engine conditions or the corresponding charge-air cooler air outlet temperature, the coolant flow rate shall be set at maximum engine power to achieve a charge-air cooler air outlet temperature that represents in-use operation.

- (iii) If the engine manufacturer specifies pressure-drop limits across the charge-air cooling system, it shall be ensured that the pressure drop across the charge-air cooling system at engine conditions specified by the manufacturer is within the manufacturer's specified limit(s). The pressure drop shall be measured at the manufacturer's specified locations.
- (b) The objective is to produce emission results that are representative of in-use operation. If good engineering judgment indicates that the specifications in this section would result in unrepresentative testing (such as overcooling of the intake air), more sophisticated set points and controls of charge-air pressure drop, coolant temperature, and flow rate may be used to achieve more representative results.

### 6.3. Engine power

#### 6.3.1. Basis for emission measurement

The basis of specific emissions measurement is uncorrected power.

#### 6.3.2. Auxiliaries to be fitted

During the test, the auxiliaries necessary for the engine operation shall be installed on the test bench according to the requirements of Annex A.5.

#### 6.3.3. Auxiliaries to be removed

Certain auxiliaries whose definition is linked with the operation of the machine and which may be mounted on the engine shall be removed for the test.

Where auxiliaries cannot be removed, the power they absorb in the unloaded condition may be determined and added to the measured engine power (see note h in the table of Annex A.5). If this value is greater than 3 per cent of the maximum power at the test speed it may be verified by the test authority. The power absorbed by auxiliaries shall be used to adjust the set values and to calculate the work produced by the engine over the test cycle.

### 6.4. Engine intake air

#### 6.4.1. Introduction

The intake-air system installed on the engine or one that represents a typical in-use configuration shall be used. This includes the charge-air cooling and exhaust gas recirculation systems.

#### 6.4.2. Intake air restriction

An engine air intake system or a test laboratory system shall be used presenting an air intake restriction within  $\pm 300$  Pa of the maximum value specified by the manufacturer for a clean air cleaner at the rated speed and full load. The static differential pressure of the restriction shall be measured at the location and at the speed and torque set points specified by the manufacturer. If the manufacturer does not specify a location, this pressure shall be measured upstream of any turbocharger or exhaust gas recirculation system connection to the intake air system. If the manufacturer does not specify speed and torque points, this pressure shall be measured while the engine outputs maximum power.

#### 6.5. Engine exhaust system

The exhaust system installed with the engine or one that represents a typical in-use configuration shall be used. For aftertreatment devices the exhaust restriction shall be defined by the manufacturer according to the aftertreatment condition (e.g. degreening/aging and regeneration/loading level). The exhaust system shall conform to the requirements for exhaust gas sampling, as set out in paragraph 9.3. An engine exhaust system or a test laboratory system shall be used presenting a static exhaust backpressure within 80 to 100 per cent of the maximum exhaust restriction at the engine speed and torque specified by the manufacturer. If the maximum restriction is 5 kPa or less, the set point shall be no less than 1.0 kPa from the maximum. If the manufacturer does not specify speed and torque points, this pressure shall be measured while the engine produces maximum power.

#### 6.6. Engine with exhaust after-treatment system

If the engine is equipped with an exhaust after-treatment system, the exhaust pipe shall have the same diameter as found in-use for at least four pipe diameters upstream of the expansion section containing the after-treatment device. The distance from the exhaust manifold flange or turbocharger outlet to the exhaust after-treatment system shall be the same as in the vehicle configuration or within the distance specifications of the manufacturer. The exhaust backpressure or restriction shall follow the same criteria as above, and may be set with a valve. The after-treatment container may be removed during dummy tests and during engine mapping, and replaced with an equivalent container having an inactive catalyst support.

The emissions measured on the test cycle shall be representative of the emissions in the field. In the case of an engine equipped with an exhaust after-treatment system that requires the consumption of a reagent, the reagent used for all tests shall be declared by the manufacturer.



For engines equipped with exhaust after-treatment systems that are regenerated on an infrequent (periodic) basis, as described in paragraph 6.6.2, emission results shall be adjusted to account for regeneration events. In this case, the average emission depends on the frequency of the regeneration event in terms of fraction of tests during which the regeneration occurs. After-treatment systems with continuous regeneration according to paragraph 6.6.1. do not require a special test procedure.

6.6.1. Continuous regeneration

For an exhaust aftertreatment system based on a continuous regeneration process the emissions shall be measured on an aftertreatment system that has been stabilized so as to result in repeatable emissions behaviour. The regeneration process shall occur at least once during the NRTC test and the manufacturer shall declare the normal conditions under which regeneration occurs (soot load, temperature, exhaust back-pressure, etc). In order to demonstrate that the regeneration process is continuous, at least 3 NRTC hot start tests shall be conducted. During the tests, exhaust temperatures and pressures shall be recorded (temperature before and after the aftertreatment system, exhaust back pressure, etc). The aftertreatment system is considered to be satisfactory if the conditions declared by the manufacturer occur during the test during a sufficient time and the emission results do not scatter by more than  $\pm 15$  per cent. If the exhaust aftertreatment has a security mode that shifts to an infrequent (periodic) regeneration mode, it shall be checked according to paragraph 6.6.2. For that specific case, the applicable emission limits could be exceeded and would not be weighted.

6.6.2. Infrequent (periodic) regeneration

This provision only applies for engines equipped with emission controls that are regenerated on a periodic basis. For engines which are run on the discrete mode cycle this procedure cannot be applied.

The emissions shall be measured on at least three NRTC hot start tests or RMC tests, one during and two outside a regeneration event on a stabilized aftertreatment system. The regeneration process shall occur at least once during the NRTC or RMC test. If regeneration takes longer than one NRTC or RMC test, consecutive NRTC or RMC tests shall be run until regeneration is completed. The engine may be equipped with a switch capable of preventing or permitting the regeneration process provided this operation has no effect on the original engine calibration.

The manufacturer shall declare the normal parameter conditions under which the regeneration process occurs (soot load, temperature, exhaust back-pressure, etc.). The manufacturer shall also provide the frequency of the regeneration event in terms of fraction of tests during which the regeneration occurs ( $F$ ). The exact procedure to determine this fraction shall be agreed by the type approval or certification authority based upon good engineering judgement.

For a regeneration test, the manufacturer shall provide an aftertreatment system that has been loaded. Regeneration shall not occur during this engine conditioning phase. As an option, the manufacturer may run consecutive NRTC hot start or RMC tests until the aftertreatment system is loaded. Emissions measurement is not required on all tests.

Average emissions between regeneration phases shall be determined from the arithmetic mean of several approximately equidistant NRTC hot start or RMC tests. As a minimum, at least one NRTC or RMC as close as possible prior to a regeneration test and one NRTC or RMC immediately after a regeneration test shall be conducted.

During the regeneration test, all the data needed to detect regeneration shall be recorded (CO or NO<sub>x</sub> emissions, temperature before and after the after-treatment system, exhaust back pressure, etc.). During the regeneration process, the applicable emission limits may be exceeded. The test procedure is schematically shown in figure 6.1.

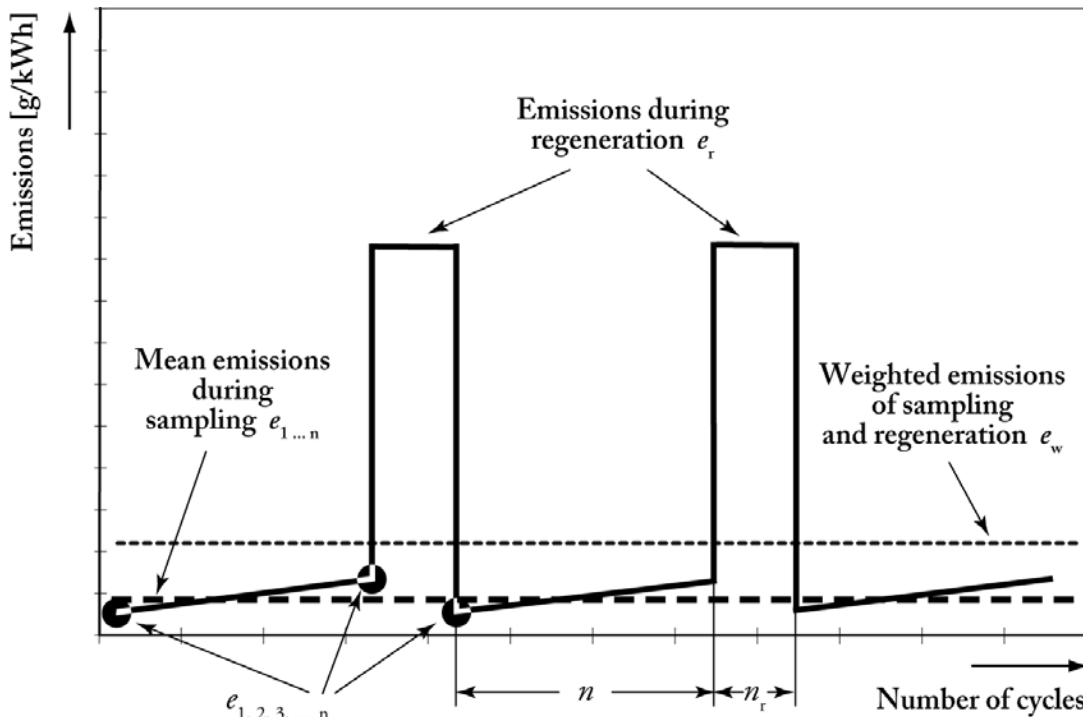

Figure 6.1 - Scheme of infrequent (periodic) regeneration with  $n$  number of measurements and  $n_r$  number of measurements during regeneration.

The average specific emission rate related to hot start  $\bar{e}_w$  [g/kWh] shall be weighted as follows (see figure 6.1):

$$\bar{e}_w = \bar{e}_r \cdot F + (1 - F) \cdot \bar{e} \tag{6-3}$$

Where:

$F$  = frequency of the regeneration event in terms of fraction of tests during which the regeneration occurs [-]

$\bar{e}$  = average specific emission from a test in which the regeneration does not occur [g/kWh]

$\bar{e}_r$  = average specific emission from a test in which the regeneration occurs [g/kWh]

At the choice of the manufacturer and based on upon good engineering analysis, the regeneration adjustment factor  $k_r$ , expressing the average emission rate, may be calculated either multiplicative or additive as follows:

$$k_r = \frac{\bar{e}_w}{\bar{e}} \quad (\text{multiplicative adjustment factor}) \quad (6-4)$$

or

$$k_{Ur} = \bar{e}_w - \bar{e} \quad (\text{upward adjustment factor}) \quad (6-5)$$

$$k_{Dr} = \bar{e}_w - \bar{e}_r \quad (\text{downward adjustment factor}) \quad (6-6)$$

Upward adjustment factors are added to measured emission rates for all tests in which the regeneration does not occur. Downward adjustment factors are added to measured emission rates for all tests in which the regeneration occurs. The occurrence of the regeneration shall be identified in a manner that is readily apparent during all testing. Where no regeneration is identified, the upward adjustment factor shall be applied.

With reference to Annexes A.7.-8. on brake specific emission calculations, the regeneration adjustment factor:

- (a) shall be applied to the results of the weighted NRTC test and discrete mode cycle,
- (b) may be applied to the ramped modal cycles and cold NRTC, if a regeneration occurs during the cycle,
- (c) may be extended to other members of the same engine family,
- (d) may be extended to other engine families using the same aftertreatment system with the prior approval of the type approval or certification authority based on technical evidence to be supplied by the manufacturer that the emissions are similar.

The following options shall be considered:

- (a) A manufacturer may elect to omit adjustment factors for one or more of its engine families (or configurations) because the effect of the regeneration is small, or because it is not practical to identify when regenerations occur. In these cases, no adjustment factor shall be used, and the manufacturer is liable for compliance with the emission limits for all tests, without regard to whether a regeneration occurs.

- (b) Upon request by the manufacturer, the type-approval or certification authority may account for regeneration events differently than is provided in paragraph (a). However, this option only applies for events that occur extremely infrequently, and which cannot be practically addressed using the adjustment factors described in paragraph (a).

6.7. Cooling system

An engine cooling system with sufficient capacity to maintain the engine, with its intake-air, oil, coolant, block and head temperatures, at normal operating temperatures prescribed by the manufacturer shall be used. Laboratory auxiliary coolers and fans may be used.

6.8. Lubricating oil

The lubricating oil shall be specified by the manufacturer and be representative of lubricating oil available in the market; the specifications of the lubricating oil used for the test shall be recorded and presented with the results of the test.

6.9. Specification of the reference fuel

The use of one standardized reference fuel has always been considered as an ideal condition for ensuring the reproducibility of regulatory emission testing, and Contracting Parties are encouraged to use such fuel in their compliance testing. However, until performance requirements (i.e. limit values) have been introduced into this gtr, Contracting Parties to the 1998 Agreement are allowed to define their own reference fuel for their national legislation, to address the actual situation of market fuel for engines in use.

The reference fuels for compression ignition engines of the European Union, the United States of America and Japan are listed in Annex A.6. Since fuel characteristics influence the engine exhaust gas emission, the characteristics of the fuel used for the test shall be determined, recorded and declared with the results of the test.

The fuel temperature shall be in accordance with the manufacturer's recommendations. The fuel temperature shall be measured at the inlet to the fuel injection pump or as specified by the manufacturer, and the location of measurement recorded.

6.10. Crankcase emissions

No crankcase emissions shall be discharged directly into the ambient atmosphere, with the following exception: engines equipped with turbochargers, pumps, blowers, or superchargers for air induction may discharge crankcase emissions to the ambient atmosphere if the emissions are added to the exhaust emissions (either physically or mathematically) during all emission testing. Manufacturers taking

advantage of this exception shall install the engines so that all crankcase emission can be routed into the emissions sampling system. For the purpose of this paragraph, crankcase emissions that are routed into the exhaust upstream of exhaust aftertreatment during all operation are not considered to be discharged directly into the ambient atmosphere.

Open crankcase emissions shall be routed into the exhaust system for emission measurement, as follows:

- (a) The tubing materials shall be smooth-walled, electrically conductive, and not reactive with crankcase emissions. Tube lengths shall be minimized as far as possible.
- (b) The number of bends in the laboratory crankcase tubing shall be minimized, and the radius of any unavoidable bend shall be maximized.
- (c) The laboratory crankcase exhaust tubing shall meet the engine manufacturer's specifications for crankcase back pressure.
- (d) The crankcase exhaust tubing shall connect into the raw exhaust downstream of any aftertreatment system, downstream of any installed exhaust restriction, and sufficiently upstream of any sample probes to ensure complete mixing with the engine's exhaust before sampling. The crankcase exhaust tube shall extend into the free stream of exhaust to avoid boundary-layer effects and to promote mixing. The crankcase exhaust tube's outlet may orient in any direction relative to the raw exhaust flow.

## 7. TEST PROCEDURES

### 7.1. Introduction

This chapter describes the determination of brake specific emissions of gaseous and particulate pollutants on engines to be tested. The test engine shall be the parent engine configuration for the engine family as specified in paragraph 5.2.

A laboratory emission test consists of measuring emissions and other parameters for the test cycles specified in this gtr. The following aspects are treated:

- (a) the laboratory configurations for measuring the brake specific emissions (para. 7.2.);
- (b) the pre-test and post-test verification procedures (para. 7.3.);
- (c) the test cycles (para. 7.4.);
- (d) the general test sequence (para. 7.5.);
- (e) the engine mapping (para. 7.6.);
- (f) the test cycle generation (para. 7.7.);
- (g) the specific test cycle running procedure (para. 7.8.).

## 7.2. Principle of emission measurement

To measure the brake-specific emissions the engine shall be operated over the test cycles defined in paragraph 7.4., as applicable. The measurement of brake-specific emissions requires the determination of the mass of pollutants in the exhaust (i.e. HC, NMHC, CO, NO<sub>x</sub> and PM) and the corresponding engine work.

### 7.2.1. Mass of constituent

The total mass of each constituent shall be determined over the applicable test cycle by using the following methods:

#### 7.2.1.1. Continuous sampling

In continuous sampling, the constituent's concentration is measured continuously from raw or dilute exhaust. This concentration is multiplied by the continuous (raw or dilute) exhaust flow rate at the emission sampling location to determine the constituent's flow rate. The constituent's emission is continuously summed over the test interval. This sum is the total mass of the emitted constituent.

#### 7.2.1.2. Batch sampling

In batch sampling, a sample of raw or dilute exhaust is continuously extracted and stored for later measurement. The extracted sample shall be proportional to the raw or dilute exhaust flow rate. Examples of batch sampling are collecting diluted gaseous emissions in a bag and collecting PM on a filter. In principle the method of emission calculation is done as follows: the batch sampled concentrations are multiplied by the total mass or mass flow (raw or dilute) from which it was extracted during the test cycle. This product is the total mass or mass flow of the emitted constituent. To calculate the PM concentration, the PM deposited onto a filter from proportionally extracted exhaust shall be divided by the amount of filtered exhaust.

#### 7.2.1.3. Combined sampling

Any combination of continuous and batch sampling is permitted (e.g. PM with batch sampling and gaseous emissions with continuous sampling).

The following figure 7.1 illustrates the two aspects of the test procedures for measuring emissions: the equipments with the sampling lines in raw and diluted exhaust gas and the operations requested to calculate the pollutant emissions in steady-state and transient test cycles (figure 7.1).

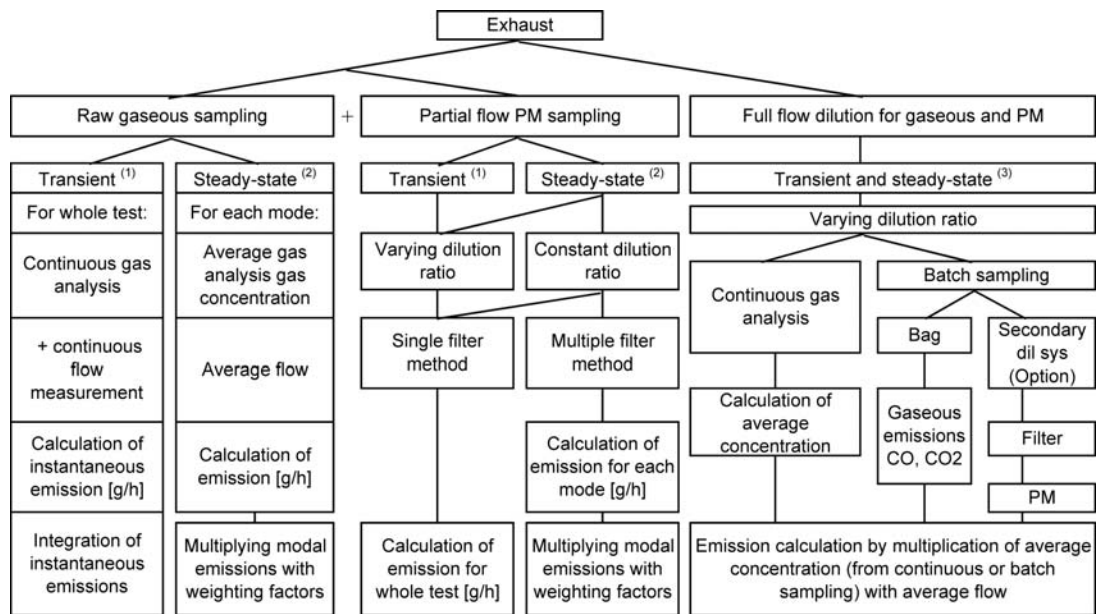

(1) Transient and Ramped Modal Test Cycle; (2) Discrete Mode Steady State Cycle; (3) Transient, ramped modal and discrete mode Steady-State Cycles

Figure 7.1 – Requested operations to calculate the engine emissions in steady-state and transient test cycles (see Annexes A.7. and A.8.)

Note on figure 7.1: The term "Partial flow PM sampling" includes the partial flow dilution to extract only raw exhaust with constant or varying dilution ratio.

### 7.2.2. Work determination

The work shall be determined over the test cycle by synchronously multiplying speed and brake torque to calculate instantaneous values for engine brake power. Engine brake power shall be integrated over the test cycle to determine total work.

### 7.3. Verification and calibration

#### 7.3.1. Pre-test procedures

##### 7.3.1.1. Preconditioning

To achieve stable conditions, the sampling system and the engine shall be preconditioned before starting a test sequence as specified in paragraphs 7.3. and 7.4. The preconditioning for cooling down the engine in view of a cold start transient test is specially indicated in paragraph 7.4.2.

##### 7.3.1.2. Verification of HC contamination

If there is any presumption of an essential HC contamination of the exhaust gas measuring system, the contamination with HC may be checked with zero gas and the

hang-up may then be corrected. If the amount of contamination of the measuring system and the background HC system has to be checked, it shall be conducted within 8 hours of starting each test-cycle. The values shall be recorded for later correction. Before this check, the leak check has to be performed and the FID analyzer has to be calibrated.

#### 7.3.1.3. Preparation of measurement equipment for sampling

The following steps shall be taken before emission sampling begins:

- (a) Leak checks shall be performed within 8 hours prior to emission sampling according to paragraph 8.1.8.7.
- (b) For batch sampling, clean storage media shall be connected, such as evacuated bags or tare-weighed filters.
- (c) All measurement instruments shall be started according to the instrument manufacturer's instructions and good engineering judgment.
- (d) Dilution systems, sample pumps, cooling fans, and the data-collection system shall be started.
- (e) The sample flow rates shall be adjusted to desired levels, using bypass flow, if desired.
- (f) Heat exchangers in the sampling system shall be pre-heated or pre-cooled to within their operating temperature ranges for a test.
- (g) Heated or cooled components such as sample lines, filters, chillers, and pumps shall be allowed to stabilize at their operating temperatures.
- (h) Exhaust dilution system flow shall be switched on at least 10 minutes before a test sequence.
- (i) Calibration of gas analyzers and zeroing of continuous analyzers shall be carried out according to the procedure of the next paragraph 7.3.1.4.
- (k) Any electronic integrating devices shall be zeroed or re-zeroed, before the start of any test interval.

#### 7.3.1.4. Calibration of gas analyzers

Appropriate gas analyzer ranges shall be selected. Emission analyzers with automatic or manual range switching are allowed. During a ramped modal or a NRTC test and during a sampling period of a gaseous emission at the end of each mode for discrete mode testing, the range of the emission analyzers may not be switched. Also the gains of an analyzer's analogue operational amplifier(s) may not be switched during a test cycle.

All continuous analyzers shall be zeroed and spanned using internationally-traceable gases that meet the specifications of paragraph 9.5.1. FID analyzers shall be spanned on a carbon number basis of one ( $C_1$ ).

#### 7.3.1.5. PM filter preconditioning and tare weighing

The procedures for PM filter preconditioning and tare weighing shall be followed according to paragraph 8.2.3.



7.3.2. Post-test procedures

The following steps shall be taken after emission sampling is complete:

7.3.2.1. Verification of proportional sampling

For any proportional batch sample, such as a bag sample or PM sample, it shall be verified that proportional sampling was maintained according to paragraph 8.2.1. For the single filter method and the discrete steady-state test cycle, effective PM weighting factor shall be calculated. Any sample that does not fulfil the requirements of paragraph 8.2.1. shall be voided.

7.3.2.2. Post-test PM conditioning and weighing

Used PM sample filters shall be placed into covered or sealed containers or the filter holders shall be closed, in order to protect the sample filters against ambient contamination. Thus protected, the loaded filters have to be returned to the PM-filter conditioning chamber or room. Then the PM sample filters shall be conditioned and weighted accordingly to paragraph 8.2.4. (PM filter post-conditioning and total weighing procedures).

7.3.2.3. Analysis of gaseous batch sampling

As soon as practical, the following shall be performed:

- (a) All batch gas analyzers shall be zeroed and spanned no later than 30 minutes after the test cycle is complete or during the soak period if practical to check if gaseous analyzers are still stable.
- (b) Any conventional gaseous batch samples shall be analyzed no later than 30 minutes after the hot-start test cycle is complete or during the soak period.
- (c) The background samples shall be analyzed no later than 60 minutes after the hot-start test cycle is complete.

7.3.2.4. Drift verification

After quantifying exhaust gases, drift shall be verified as follows:

- (a) For batch and continuous gas analyzers, the mean analyzer value shall be recorded after stabilizing a zero gas to the analyzer. Stabilization may include time to purge the analyzer of any sample gas, plus any additional time to account for analyzer response.
- (b) The mean analyzer value shall be recorded after stabilizing the span gas to the analyzer. Stabilization may include time to purge the analyzer of any sample gas, plus any additional time to account for analyzer response.
- (c) These data shall be used to validate and correct for drift as described in paragraph 8.2.2.

#### 7.4. Test cycles

The following duty cycles apply:

- (a) for variable-speed engines, the 8-mode test cycle or the corresponding ramped modal cycle, and the transient cycle NRTC as specified in Annex A.1.;
- (b) for constant-speed engines, the 5-mode test cycle or the corresponding ramped modal cycle as specified in Annex A.1.

##### 7.4.1. Steady-state test cycles

Steady-state test cycles are specified in Annex A.1. as a list of discrete modes (operating points), where each operating point has one value of speed and one value of torque. A steady-state test cycle shall be measured with a warmed up and running engine according to manufacturer's specification. A steady-state test cycle may be run as a discrete-mode cycle or a ramped-modal cycle, as explained in the following paragraphs.

##### 7.4.1.1. Steady-state discrete mode test cycles

The steady-state discrete 8-mode test cycle consists of eight speed and load modes (with the respective weighing factor for each mode) which cover the typical operating range of variable speed engines. The cycle is shown in Annex A.1.

The steady-state discrete 5-mode constant-speed test cycle consists of five load modes (with the respective weighing factor for each mode) all at rated speed which cover the typical operating range of constant speed engines. The cycle is shown in Annex A.1.

##### 7.4.1.2. Steady-state ramped test cycles

The ramped modal test cycles (RMC) are hot running cycles where emissions shall be started to be measured after the engine is started, warmed up and running as specified in paragraph 7.8.2.1. The engine shall be continuously controlled by the test bed control unit during the RMC test cycle. The gaseous and particulate emissions shall be measured and sampled continuously during the RMC test cycle in the same way as in a transient cycle.

In case of the 5-mode test cycle the RMC consists of the same modes in the same order as the corresponding discrete steady-state test cycle. For the 8-mode test cycle the RMC has one mode more (split idle mode) and the mode sequence is not the same as the corresponding steady-state discrete mode cycle, in order to avoid extreme changes in the after-treatment temperature. The length of the modes shall be selected to be equivalent to the weighting factors of the corresponding discrete steady-state test cycle. The change in engine speed and load from one mode to the next one has to be linearly controlled in a time of  $20 \pm 1$  seconds. The mode change time is part of the new mode (including the first mode).

#### 7.4.2. Transient test cycle (NRTC)

The Non-Road Transient Cycle (NRTC) is specified in Annex A.1. as a second-by-second sequence of normalized speed and torque values. In order to perform the test in an engine test cell, the normalized values shall be converted to their equivalent reference values for the individual engine to be tested, based on specific speed and torque values identified in the engine-mapping curve. The conversion is referred to as denormalization, and the resulting test cycle is the reference NRTC test cycle of the engine to be tested (see paragraph 7.7.).

A graphical display of the normalized NRTC dynamometer schedule is shown here below.

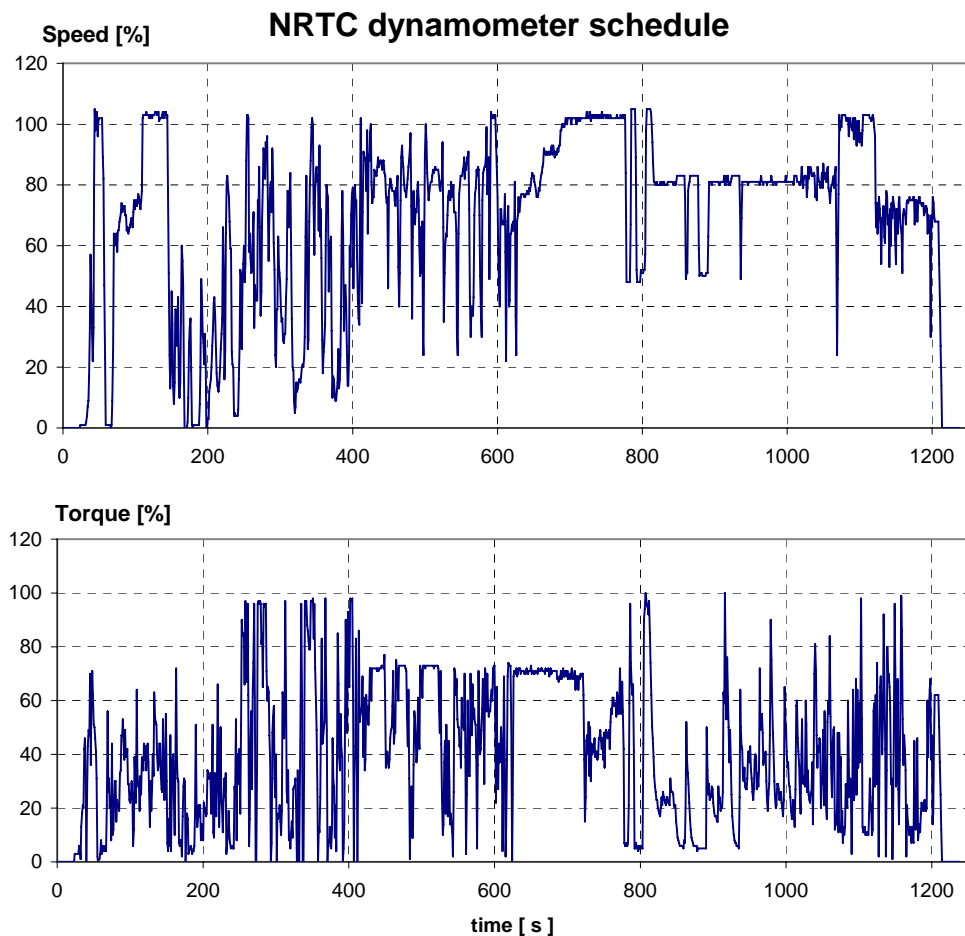

Figure 7.2 - NRTC normalized dynamometer schedule

The transient test cycle shall be run twice (see paragraph 7.8.3.):

- (a) As cold start after the engine and aftertreatment systems have cooled down to room temperature after natural engine cool down, or as cold start after forced cool down and the engine, coolant and oil temperatures, aftertreatment systems and all engine control devices are stabilized between 20 and 30 °C. The

measurement of the cold start emissions shall be started with the start of the cold engine.

- (b) Hot soak period – Immediately upon completion of the cold start phase, the engine shall be conditioned for the hot start by a 20 minutes  $\pm$  1 minute hot soak period.
- (c) The hot-start shall be started immediately after the soak period with the cranking of the engine. The gaseous analyzers shall be switched on at least 10 seconds before the end of the soak period to avoid switching signal peaks. The measurement of emissions shall be started in parallel with the start of the hot start phase including the cranking of the engine.

Brake specific emissions expressed in (g/kWh) shall be determined by using the procedures of this section for both the cold and hot start test cycles. Composite weighted emissions shall be computed by weighting the cold start results by 10 per cent and the hot start results by 90 per cent as detailed in Annexes A.7.-A.8.

#### 7.5. General test sequence

To measure engine emissions the following steps have to be performed:

- (a) The engine test speeds and test loads have to be defined for the engine to be tested by measuring the max torque (for constant speed engines) or max torque curve (for variable speed engines) as function of the engine speed .
- (b) Normalized test cycles have to be denormalized with the torque (for constant speed engines) or speeds and torques (for variable speed engines) found in the previous paragraph 7.5. (a).
- (c) The engine, equipment, and measurement instruments shall be prepared for the following emission test or test series (cold and hot cycle) in advance.
- (d) Pre-test procedures shall be performed to verify proper operation of certain equipment and analyzers. All analysers have to be calibrated. All pre-test data shall be recorded.
- (e) The engine shall be started (NRTC) or kept running (steady-state cycles) at the beginning of the test cycle and the sampling systems shall be started at the same time.
- (f) Emissions and other required parameters shall be measured or recorded during sampling time (for NRTC and steady-state ramped modal cycles throughout the whole test cycle).
- (g) Post-test procedures shall be performed to verify proper operation of certain equipment and analyzers.
- (h) PM filter(s) shall be pre-conditioned, weighed (empty weight), loaded, re-conditioned, again weighed (loaded weight) and then samples shall be evaluated according to pre- (7.3.1.4.) and post-test (7.3.2.2.) procedures.
- (i) Emission test results shall be evaluated.

The following diagram gives an overview about the procedures needed to conduct NRMM test cycles with measuring exhaust engine emissions.

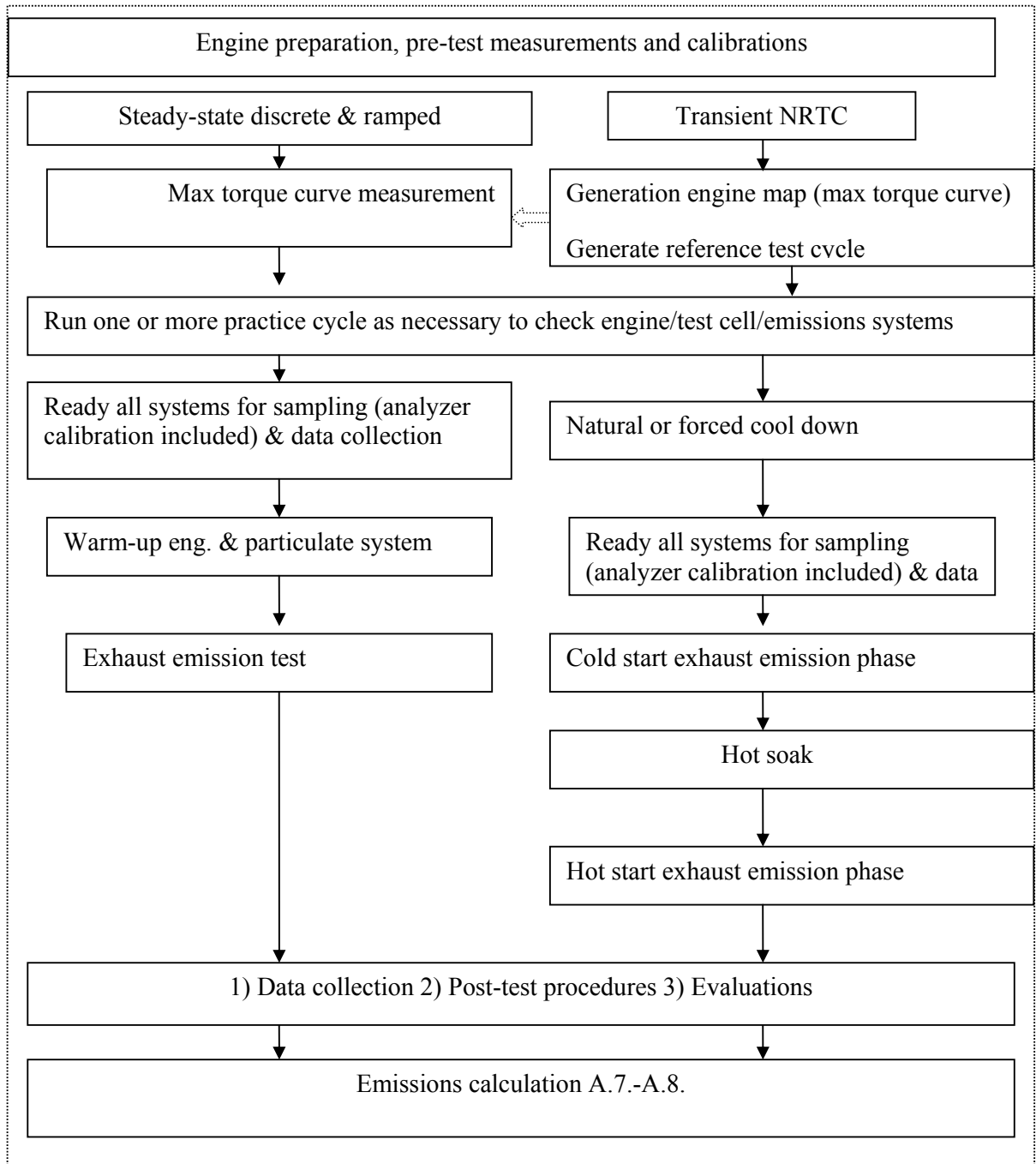

Figure 7.3 – Test sequence

### 7.5.1. Engine starting, and restarting

#### 7.5.1.1. Engine start

The engine shall be started:

- (a) as recommended in the owner's manual using a production starter motor or air-start system and either an adequately charged battery, a suitable power supply or a suitable compressed air source or
- (b) by using the dynamometer to crank the engine until it starts. Typically motor the engine within  $\pm 25$  per cent of its typical in-use cranking speed or start the engine by linearly increasing the dynamometer speed from zero to  $100 \text{ min}^{-1}$  below low idle speed but only until the engine starts.

Cranking shall be stopped within 1 s of starting the engine. If the engine does not start after 15 s of cranking, cranking shall be stopped and the reason for the failure to start determined, unless the owner's manual or the service-repair manual describes a longer cranking time as normal.

#### 7.5.1.2. Engine stalling

- (a) If the engine stalls anywhere during the cold start test of the NRTC, the test shall be voided.
- (b) If the engine stalls anywhere during the hot start test of the NRTC, the test shall be voided. The engine shall be soaked according to paragraph 7.8.3., and the hot start test repeated. In this case, the cold start test does not need to be repeated.
- (c) If the engine stalls anywhere during the steady-state cycle (discrete or ramped), the test shall be voided and be repeated beginning with the engine warm-up procedure. In the case of PM measurement utilizing the multi-filter method (one sampling filter for each operating mode), the test shall be continued by stabilizing the engine at the previous mode for engine temperature conditioning and then initiating measurement with the mode where the engine stalled.

### 7.6. Engine mapping

Before starting the engine mapping, the engine shall be warmed up and towards the end of the warm up it shall be operated for at least 10 minutes at maximum power or according to the recommendation of the manufacturer and good engineering judgment in order to stabilize the engine coolant and lube oil temperatures. When the engine is stabilized, the engine mapping shall be performed.

Except constant speed engines, engine mapping shall be performed with fully open fuel lever or governor using discrete speeds in ascending order. The minimum and maximum mapping speeds are defined as follows:

Minimum mapping speed = warm idle speed

Maximum mapping speed =  $n_{hi} \times 1.02$  or speed where max torque drops off to zero, whichever is smaller.

Where  $n_{hi}$  is the high speed, defined as the highest engine speed where 70 per cent of the rated power is delivered.

If the highest speed is unsafe or unrepresentative (e.g., for ungoverned engines), good engineering judgment shall be used to map up to the maximum safe speed or the maximum representative one.

7.6.1. Engine mapping for steady-state 8-mode cycle

In the case of engine mapping for the steady-state 8-mode cycle (only for engines which have not to run the NRTC cycle), good engineering judgment shall be used to select a sufficient number (20 to 30) of evenly spaced set-points. At each setpoint, speed shall be stabilized and torque allowed to stabilize at least for 15 seconds. The mean speed and torque shall be recorded at each set-point. Linear interpolation shall be used to determine the 8-mode test speeds and torques if needed. If the derived test speeds and loads do not deviate for more than  $\pm 2.5$  per cent from the speeds and torques indicated by the manufacturer, the manufacturer defined speeds and loads shall be applied. When engines shall be run on the NRTC too, then the NRTC engine mapping curve shall be used to determine steady-state test speeds and torques.

7.6.2. Engine mapping for NRTC cycle

The engine mapping shall be performed according to the following procedure:

- (a) The engine shall be unloaded and operated at idle speed.
  - (i) For engines with a low-speed governor, the operator demand shall be set to the minimum, the dynamometer or another loading device shall be used to target a torque of zero on the engine's primary output shaft and the engine shall be allowed to govern the speed. This warm idle speed shall be measured.
  - (ii) For engines without a low-speed governor, the dynamometer shall be set to target a torque of zero on the engine's primary output shaft, and the operator demand shall be set to control the speed to the manufacturer-declared lowest engine speed possible with minimum load (also known as manufacturer-declared warm idle speed).
  - (iii) The manufacturer declared idle torque may be used for all variable-speed engines (with or without a low-speed governor), if a nonzero idle torque is representative of in-use operation.
- (b) Operator demand shall be set to maximum and engine speed shall be controlled to between warm idle and 95 per cent of its warm idle speed. For engines with reference duty cycles, which lowest speed is greater than warm idle speed, the mapping may be started at between the lowest reference speed and 95 per cent of the lowest reference speed.
- (c) The engine speed shall be increased at an average rate of  $8 \pm 1 \text{ min}^{-1}/\text{s}$  or the engine shall be mapped by using a continuous sweep of speed at a constant rate such that it takes 4 to 6 min to sweep from minimum to maximum mapping speed. The mapping speed range shall be started between warm idle and 95 per cent of warm idle and ended at the highest speed above maximum

power at which less than 70 per cent of maximum power occurs. If this highest speed is unsafe or unrepresentative (e.g., for ungoverned engines), good engineering judgment shall be used to map up to the maximum safe speed or the maximum representative speed. Engine speed and torque points shall be recorded at a sample rate of at least 1 Hz.

- (d) If a manufacturer believes that the above mapping techniques are unsafe or unrepresentative for any given engine, alternate mapping techniques may be used. These alternate techniques shall satisfy the intent of the specified mapping procedures to determine the maximum available torque at all engine speeds achieved during the test cycles. Deviations from the mapping techniques specified in this paragraph for reasons of safety or representativeness shall be approved by the type approval or certification authority along with the justification for their use. In no case, however, the torque curve shall be run by descending engine speeds for governed or turbocharged engines.
- (e) An engine need not be mapped before each and every test cycle. An engine shall be remapped if:
  - (i) an unreasonable amount of time has transpired since the last map, as determined by good engineering judgement, or
  - (ii) physical changes or recalibrations have been made to the engine which potentially affect engine performance, or
  - (iii) the atmospheric pressure near the engine's air inlet is not within  $\pm 5$  kPa of the value recorded at the time of the last engine map.

#### 7.6.3. Engine mapping for constant-speed engines

- (a) The engine may be operated with a production constant-speed governor or a constant-speed governor maybe simulated by controlling engine speed with an operator demand control system. Either isochronous or speed-droop governor operation shall be used, as appropriate.
- (b) With the governor or simulated governor controlling speed using operator demand, the engine shall be operated at no-load governed speed (at high speed, not low idle) for at least 15 seconds.
- (c) The dynamometer shall be used to increase torque at a constant rate. The map shall be conducted such that it takes 2 to 4 min to sweep from no-load governed speed to the maximum torque. During the engine mapping actual speed and torque shall be recorded with at least 1 Hz.
- (d) In case of a gen-set engine to be used for 50 Hz and 60 Hz power generation (1500 and 1800  $\text{min}^{-1}$ ) engine has to be tested in both constant speeds separately.

For constant speed engines good engineering judgment shall be used to apply other methods to record max torque and power at the defined operating speed(s).



7.7. Test cycle generation

7.7.1. Generation of steady-state test cycles

7.7.1.1. Rated speed

For engines that are tested with the steady state and also the transient schedule, the denormalization speed shall be calculated according to the transient procedure (paragraphs 7.6.2. and 7.7.2.1. and figure 7.3).

If the calculated denormalization speed ( $n_{denorm}$ ) is within  $\pm 2.5$  per cent of the denormalization speed as declared by the manufacturer, the declared denormalization speed ( $n_{denorm}$ ) may be used for the emission test. If the tolerance is exceeded, the calculated denormalization speed ( $n_{denorm}$ ) shall be used for the emissions test. In case of the steady state cycle the calculated denormalization speed ( $n_{denorm}$ ) is tabled as rated speed.

For engines that are not tested with the transient schedule, the rated speed of tables in Annex A.1. for the 8-mode discrete and the derived ramped mode cycle shall be calculated according to the procedure (paragraphs 7.6.1. and 7.7.2.1. and figure 7.3). The rated speed is defined in paragraph 3.1.53.

7.7.1.2. Generation of steady-state 8-mode test cycle (discrete and ramp modal)

The intermediate speed shall be determined from the calculations according to its definition (see paragraph 3.1.32.).

The engine setting for each test mode shall be calculated using the formula:

$$S = \left( (P_{max} + P_{AUX}) \cdot \frac{L}{100} \right) - P_{AUX} \quad (7-1)$$

Where:

$S$  = dynamometer setting in kW

$P_{max}$  = maximum observed or declared power at the test speed under the test conditions (specified by the manufacturer) in kW

$P_{AUX}$  = declared total power absorbed by auxiliaries fitted for the test (see paragraph 6.3.) at the test speed in kW

$L$  = per cent torque

During the test cycle, the engine shall be operated at the engine speeds and torques that are defined in Annex A.1.

The maximum mapping torque values at the specified test speeds shall be derived from the mapping curve (see paragraph 7.6.1. or 7.6.2). "Measured" values are either directly measured during the engine mapping process or they are determined from the engine map. "Declared" values are specified by the manufacturer. When both

measured and declared values are available, declared values may be used instead of torques if they don't deviate more than  $\pm 2.5$  per cent. Otherwise, measured torques derived from the engine mapping shall be used.

#### 7.7.1.3. Generation of steady-state 5-mode test cycle (discrete and ramp modal)

During the test cycle, the engine shall be operated at the engine speeds and torques that are defined in Annex A.1.

The maximum mapping torque value at the specified rated speed (see paragraph 7.7.1.1.) shall be used to generate the 5-mode test cycle. A warm minimum torque that is representative of in-use operation may be declared. For example, if the engine is typically connected to a machine that does not operate below a certain minimum torque, this torque may be declared and used for cycle generation. When both measured and declared values are available for the maximum test torque for cycle generation, the declared value may be used instead of the measured value if it is within 95 to 100 per cent of the measured value.

The torque figures are percentage values of the torque corresponding to the prime power <sup>4/</sup> rating. The prime power is defined as the maximum power available during a variable power sequence, which may be run for an unlimited number of hours per year, between stated maintenance intervals and under the stated ambient conditions. The maintenance shall be carried out as prescribed by the manufacturer.

#### 7.7.2. Generation of transient test cycle (NRTC denormalization)

Annex A.1. defines applicable test cycles in a normalized format. A normalized test cycle consists of a sequence of paired values for speed and torque per cent.

Normalized values of speed and torque shall be transformed using the following conventions:

- (a) The normalized speed shall be transformed into a sequence of reference speeds,  $n_{ref}$ , according to paragraph 7.7.2.2.
- (b) The normalized torque is expressed as a percentage of the mapped torque at the corresponding reference speed. These normalized values shall be transformed into a sequence of reference torques,  $T_{ref}$ , according to paragraph 7.7.2.3.
- (c) The reference speed and reference torque values expressed in coherent units are multiplied to calculate the reference power values.

##### 7.7.2.1. Denormalization speed ( $n_{denorm}$ )

The denormalization speed ( $n_{denorm}$ ) is selected to equal the 100 per cent normalized speed values specified in the engine dynamometer schedule of Annex A.1. The

---

<sup>4/</sup> For further understanding of the prime power definition, see figure 2 of ISO 8528-1:1993(E) standard.

reference engine cycle resulting from denormalization to the reference speed, depends on the selection of the proper denormalization speed ( $n_{denorm}$ ). For the calculation of the denormalization speed ( $n_{denorm}$ ), obtained from the measured mapping curve, either of the following equivalent formulations can be used:

$$(a) \quad n_{denorm} = n_{lo} + 0.95 \times (n_{hi} - n_{lo}) \quad (7-2)$$

Where:

$n_{denorm}$  = denormalization speed  
 $n_{hi}$  = high speed (see paragraph 3.1.30.)  
 $n_{lo}$  = low speed (see paragraph 3.1.34.)

(b)  $n_{denorm}$  corresponding to the longest vector defined as:

$$n_{denorm} = n_i \text{ at the maximum of } (n_{normi}^2 + P_{normi}^2) \quad (7-3)$$

Where:

$i$  = an indexing variable that represents one recorded value of an engine map  
 $n_{normi}$  = an engine speed normalized by dividing it by  $n_{Pmax}$ .  
 $P_{normi}$  = an engine power normalized by dividing it by  $P_{max}$ .

Note that if multiple maximum values are found, the denormalization speed ( $n_{denorm}$ ) should be taken as the lowest speed of all points with the same maximum sum of squares. A higher declared speed may be used if the length of the vector at the declared speed is within 2 per cent of the length of the vector at the measured value.

The Contracting Parties can determine which formula is to be used, in the case that the results from the calculations in (a) and (b) differ for more than 3 per cent.

If the falling part of the full load curve has a very steep edge, this may cause problems to drive the 105 per cent speeds of the NRTC test cycle correctly. In this case it is allowed with previous agreement with type-approval or certification authorities, to reduce the denormalization speed ( $n_{denorm}$ ) slightly (maximum 3 per cent) in order to make correct driving of the NRTC possible.

If the measured denormalization speed ( $n_{denorm}$ ) is within  $\pm 3$  per cent of the denormalization speed as declared by the manufacturer, the declared denormalization speed ( $n_{denorm}$ ) may be used for the emissions test. If the tolerance is exceeded, the measured denormalization speed ( $n_{denorm}$ ) shall be used for the emissions test.

#### 7.7.2.2. Denormalization of engine speed

The engine speed shall be denormalized using the following equation:

$$n_{ref} = \frac{\%speed \cdot (n_{denorm} - n_{idle})}{100} + n_{idle} \quad (7-4)$$

Where:

$n_{ref}$  = reference speed  
 $n_{denorm}$  = denormalization speed  
 $n_{idle}$  = idle speed  
 $\%speed$  = tabled NRTC normalized speed

### 7.7.2.3. Denormalization of engine torque

The torque values in the engine dynamometer schedule of Annex A.1.4. are normalized to the maximum torque at the respective speed. The torque values of the reference cycle shall be denormalized, using the mapping curve determined according to paragraph 7.6.2., as follows:

$$T_{ref} = \frac{\%torque \cdot max.torque}{100} \quad (7-5)$$

for the respective reference speed as determined in paragraph 7.6.3.

### 7.7.2.4. Example of denormalization procedure

As an example, the following test point shall be denormalized:

$\% speed = 43$  per cent

$\% torque = 82$  per cent

Given the following values:

$n_{denorm} = 2200 \text{ min}^{-1}$

$n_{idle} = 600 \text{ min}^{-1}$

results in

$$n_{ref} = \frac{43 \cdot (2200 - 600)}{100} + 600 = 1288 \text{ min}^{-1}$$

With the maximum torque of 700 Nm observed from the mapping curve at  $1288 \text{ min}^{-1}$

$$T_{ref} = \frac{82 \times 700}{100} = 574 \text{ Nm}$$

## 7.8. Specific test cycle running procedure

### 7.8.1. Emission test sequence for discrete steady-state test cycles

#### 7.8.1.1. Engine warming-up for steady state discrete-mode test cycles

For preconditioning the engine shall be warmed up according to the recommendation of the manufacturer and good engineering judgment. Before emission sampling can start, the engine shall be running until engine temperatures (cooling water and lube oil) have been stabilized (normally at least 10 minutes) on mode 1 (100 per cent torque and rated speed for the 8-mode test cycle and at rated or nominal constant engine speed and 100 per cent torque for the 5-mode test cycle). Immediately from this engine conditioning point, the test cycle measurement starts.

Pre-test procedure according to paragraph 7.3.1. shall be performed, including analyzer calibration.

#### 7.8.1.2. Performing discrete-mode test cycles

- (a) The test shall be performed in ascending order of mode numbers as set out for the test cycle (see Annex A.1.).
- (b) Each mode has a mode length of at least 10 minutes. In each mode the engine shall be stabilized for at least 5 minutes and emissions shall be sampled for 1-3 minutes for gaseous emissions at the end of each mode. Extended time of sampling is permitted to improve the accuracy of PM sampling. The mode length shall be recorded and reported.
- (c) The particulate sampling may be done either with the single filter method or with the multiple filter method. Since the results of the methods may differ slightly, the method used shall be declared with the results.  
For the single filter method the modal weighting factors specified in the test cycle procedure and the actual exhaust flow shall be taken into account during sampling by adjusting sample flow rate and/or sampling time, accordingly. It is required that the effective weighing factor of the PM sampling is within  $\pm 0.003$  of the weighing factor of the given mode.  
Sampling shall be conducted as late as possible within each mode. For the single filter method, the completion of particulate sampling shall be coincident within  $\pm 5$  s with the completion of the gaseous emission measurement. The sampling time per mode shall be at least 20 s for the single filter method and at least 60 s for the multi-filter method. For systems without bypass capability, the sampling time per mode shall be at least 60 s for single and multiple filter methods.
- (d) The engine speed and load, intake air temperature, fuel flow and air or exhaust gas flow shall be measured for each mode at the same time interval which is used for the measurement of the gaseous concentrations.  
Any additional data required for calculation shall be recorded.
- (e) If the engine stalls or the emission sampling is interrupted at any time after emission sampling begins for a discrete mode and the single filter method, the test shall be voided and be repeated beginning with the engine warm-up procedure. In the case of PM measurement utilizing the multi-filter method (one sampling filter for each operating mode), the test shall be continued by stabilizing the engine at the previous mode for engine temperature conditioning and then initiating measurement with the mode where the engine stalled.
- (f) Post-test procedures according to paragraph 7.3.2. shall be performed.

### 7.8.1.3. Validation criteria

During each mode of the given steady-state test cycle after the initial transition period, the measured speed shall not deviate from the reference speed for more than  $\pm 1$  per cent of rated speed or  $\pm 3 \text{ min}^{-1}$ , whichever is greater except for idle which shall be within the tolerances declared by the manufacturer. The measured torque shall not deviate from the reference torque for more than  $\pm 2$  per cent of the maximum torque at the test speed.

## 7.8.2. Ramped modal test cycles

### 7.8.2.1. Engine warming-up

Before starting the steady-state ramped modal test cycles (RMC), the engine shall be warmed-up and running until engine temperatures (cooling water and lube oil) have been stabilized on 50 per cent speed and 50 per cent torque for the RMC test cycle (derived from the 8-mode test cycle) and at rated or nominal engine speed and 50 per cent torque for the RMC test cycle (derived from 5-mode test cycle). Immediately after this engine conditioning procedure, engine speed and torque shall be changed in a linear ramp of  $20 \pm 1 \text{ s}$  to the first mode of the test. In between 5 to 10 s after the end of the ramp, the test cycle measurement shall start.

### 7.8.2.2. Performing a ramped modal test cycle

The ramped modal cycles derived from 8-mode and 5-mode test cycle are shown in Annex A.1.

The engine shall be operated for the prescribed time in each mode. The transition from one mode to the next shall be done linearly in  $20 \text{ s} \pm 1 \text{ s}$  following the tolerances prescribed in paragraph 7.8.2.4. (see Annex A.1.)

For ramped modal cycles, reference speed and torque values shall be generated at a minimum frequency of 1 Hz and this sequence of points shall be used to run the cycle. During the transition between modes, the denormalized reference speed and torque values shall be linearly ramped between modes to generate reference points. The normalized reference torque values shall not be linearly ramped between modes and then denormalized. If the speed and torque ramp runs through a point above the engine's torque curve, it shall be continued to command the reference torques and it shall be allowed for the operator demand to go to maximum.

Over the whole RMC test cycle (during each mode and including the ramps between the modes), the concentration of each gaseous pollutant shall be measured and the PM be sampled. The gaseous pollutants may be measured raw or diluted and be recorded continuously; if diluted, they can also be sampled into a sampling bag. The particulate sample shall be diluted with conditioned and clean air. One sample over

the complete test procedure shall be taken, and collected on a single PM sampling filter.

For calculation of the brake specific emissions, the actual cycle work shall be calculated by integrating actual engine power over the complete cycle.

7.8.2.3. Emission test sequence

- (a) Execution of the RMC, sampling exhaust gases, recording data, and integrating measured values shall be started simultaneously.
- (b) Speed and torque shall be controlled to the first mode in the test cycle.
- (c) If the engine stalls anywhere during the RMC execution, the test shall be voided. The engine shall be pre-conditioned and the test repeated.
- (c) At the end of the RMC, sampling shall be continued, except for PM sampling, operating all systems to allow system response time to elapse. Then all sampling and recording shall be stopped, including the recording of background samples. Finally, any integrating devices shall be stopped and the end of the test cycle shall be indicated in the recorded data.
- (d) Post-test procedures according to paragraph 7.4. shall be performed.

7.8.2.4. Validation criteria

RMC tests shall be validated using the regression analysis as described in paragraphs 7.8.3.3. and 7.8.3.5. The allowed RMC tolerances are given in the following table 7.1. Note that the RMC tolerances are different from the NRTC tolerances of table 7.2.

	Speed	Torque	Power
Standard error of estimate (SEE) of $y$ on $x$	maximum 1 per cent of rated speed	maximum 2 per cent of maximum engine torque	maximum 2 per cent of maximum engine power
Slope of the regression line, $a_1$	0.99 to 1.01	0.98 - 1.02	0.98 - 1.02
Coefficient of determination, $r^2$	minimum 0.990	minimum 0.950	minimum 0.950
$y$ intercept of the regression line, $a_0$	$\pm 1$ per cent of rated speed	$\pm 20$ Nm or 2 per cent of maximum torque whichever is greater	$\pm 4$ kW or 2 per cent of maximum power whichever is greater

Table 7.1: RMC Regression line tolerances

In case of running the RMC test not on a transient test bed, where the second by second speed and torque values are not available, the following validation criteria shall be used.

At each mode the requirements for the speed and torque tolerances are given in paragraph 7.8.1.3. For the 20 s linear speed and linear torque transitions between the RMC steady-state test modes (paragraph 7.4.1.2.) the following tolerances for speed and load shall be applied for the ramp, the speed shall be held linear within  $\pm 2$  per

cent of rated speed. The torque shall be held linear within  $\pm 5$  per cent of the maximum torque at rated speed.

### 7.8.3. Transient test cycle (NRTC)

Reference speeds and torques commands shall be sequentially executed to perform the transient test cycle. Speed and torque commands shall be issued at a frequency of at least 5 Hz. Because the reference test cycle is specified at 1 Hz, the in between speed and torque commands shall be linearly interpolated from the reference torque values generated from cycle generation.

Small normalized speed values near warm idle speed may cause low-speed idle governors to activate and the engine torque to exceed the reference torque even though the operator demand is at a minimum. In such cases, it is recommended to control the dynamometer so it gives priority to follow the reference torque instead of the reference speed and let the engine govern the speed.

Under cold-start conditions engines may use an enhanced-idle device to quickly warm up the engine and aftertreatment devices. Under these conditions, very low normalized speeds will generate reference speeds below this higher enhanced idle speed. In this case it is recommended controlling the dynamometer so it gives priority to follow the reference torque and let the engine govern the speed when the operator demand is at minimum.

During an emission test, reference speeds and torques and the feedback speeds and torques shall be recorded with a minimum frequency of 1 Hz, but preferably of 5 Hz or even 10 Hz. This larger recording frequency is important as it helps to minimize the biasing effect of the time lag between the reference and the measured feedback speed and torque values.

The reference and feedback speeds and torques maybe recorded at lower frequencies (as low as 1 Hz), if the average values over the time interval between recorded values are recorded. The average values shall be calculated based on feedback values updated at a frequency of at least 5 Hz. These recorded values shall be used to calculate cycle-validation statistics and total work.

#### 7.8.3.1. Engine preconditioning

To meet stable conditions for the following Emission test, the sampling system and the engine shall be preconditioned either by driving a full pre-NRTC cycle or driving the engine and the measuring systems under similar conditions as in the test cycle itself. If the test before was also a NRTC hot test, no additional conditioning is needed.

A natural or forced cool-down procedure may be applied. For forced cool-down, good engineering judgment shall be used to set up systems to send cooling air across the engine, to send cool oil through the engine lubrication system, to remove heat



from the coolant through the engine cooling system, and to remove heat from an exhaust after-treatment system. In the case of a forced after-treatment cool down, cooling air shall not be applied until the after-treatment system has cooled below its catalytic activation temperature. Any cooling procedure that results in unrepresentative emissions is not permitted.

Pre-test procedures according to paragraph 7.3.1. have to be performed, including analyzer calibration.

#### 7.8.3.2. Performing an NRTC transient cycle test

Testing shall be started as follows:

The test sequence shall commence immediately after the engine has started from cooled down condition in case of the cold NRTC test or from hot soak condition in case of the hot NRTC test. The instructions (Annex A.1.) shall be followed.

Data logging, sampling of exhaust gases and integrating measured values shall be initiated simultaneously at the start of the engine. The test cycle shall be initiated when the engine starts and shall be executed according to the schedule of Annex A.1.

At the end of the cycle, sampling shall be continued, operating all systems to allow system response time to elapse. Then all sampling and recording shall be stopped, including the recording of background samples. Finally, any integrating devices shall be stopped and the end of the test cycle shall be indicated in the recorded data.

Post-test procedures according to paragraph 7.3.2. have to be performed.

#### 7.8.3.3. Cycle validation criteria for transient test cycle

In order to check the validity of a test, the cycle-validation criteria in this paragraph shall be applied to the reference and feedback values of speed, torque, power and overall work.

#### 7.8.3.4. Calculation of cycle work

Before calculating the cycle work, any speed and torque values recorded during engine starting shall be omitted. The actual cycle work  $W_{act}$  (kWh) shall be calculated based on engine feedback speed and torque values. The reference cycle work  $W_{ref}$  (kWh) shall be calculated based on engine reference speed and torque values. The actual cycle work  $W_{act}$  is used for comparison to the reference cycle work  $W_{ref}$  and for calculating the brake specific emissions (see paragraph 7.2.)  $W_{act}$  shall be between 85 per cent and 105 per cent of  $W_{ref}$ .

7.8.3.5. Validation statistics (see Annex A.2.)

Linear regression between the reference and the feedback values shall be calculated for speed, torque and power.

To minimize the biasing effect of the time lag between the reference and feedback cycle values, the entire engine speed and torque feedback signal sequence may be advanced or delayed in time with respect to the reference speed and torque sequence. If the feedback signals are shifted, both speed and torque shall be shifted by the same amount in the same direction.

The method of least squares shall be used, with the best-fit equation having the form:

$$y = a_1x + a_0 \tag{7-6}$$

Where:

- $y$  = feedback value of speed ( $\text{min}^{-1}$ ), torque (Nm), or power (kW)
- $a_1$  = slope of the regression line
- $x$  = reference value of speed ( $\text{min}^{-1}$ ), torque (Nm), or power (kW)
- $a_0$  =  $y$  intercept of the regression line

The standard error of estimate (SEE) of  $y$  on  $x$  and the coefficient of determination ( $r^2$ ) shall be calculated for each regression line (Annex A.2.).

It is recommended that this analysis be performed at 1 Hz. For a test to be considered valid, the criteria of table 7.2 of this paragraph shall be met.

	Speed	Torque	Power
Standard error of estimate (SEE) of $y$ on $x$	$\leq 5.0$ percent of maximum test speed	$\leq 10.0$ per cent of maximum mapped torque	$\leq 10.0$ per cent of maximum mapped power
Slope of the regression line, $a_1$	0.95 to 1.03	0.83 - 1.03	0.89 - 1.03
Coefficient of determination, $r^2$	minimum 0.970	minimum 0.850	minimum 0.910
$y$ intercept of the regression line, $a_0$	$\leq 10$ per cent of idle	$\pm 20$ Nm or $\pm 2$ per cent of maximum torque whichever is greater	$\pm 4$ kW or $\pm 2$ per cent of maximum power whichever is greater

Table 7.2: Regression line tolerances

For regression purposes only, point deletions are permitted where noted in table 7.3 of this paragraph before doing the regression calculation. However, those points shall not be deleted for the calculation of cycle work and emissions. An idle point is defined as a point having a normalized reference torque of 0 per cent and a normalized reference speed of 0 per cent. Point deletion may be applied to the whole

or to any part of the cycle; points to which the point deletion is applied have to be specified.

Event	Conditions ( $n$ = engine speed, $T$ = torque)	Permitted point deletions
Minimum operator demand (idle point)	$n_{ref} = 0$ per cent and $T_{ref} = 0$ per cent and $T_{act} > (T_{ref} - 0.02 T_{maxmappedtorque})$ and $T_{act} < (T_{ref} + 0.02 T_{maxmappedtorque})$	speed and power
Minimum operator demand	$n_{act} \leq 1.02 n_{ref}$ and $T_{act} > T_{ref}$ and $n_{act} > n_{ref}$ and $T_{act} \leq T_{ref}$ and $n_{act} > 1.02 n_{ref}$ and $T_{ref} < T_{act} \leq (T_{ref} + 0.02 T_{maxmappedtorque})$	power and either torque or speed
Maximum operator demand	$n_{act} < n_{ref}$ and $T_{act} \geq T_{ref}$ and $n_{act} \geq 0.98 n_{ref}$ and $T_{act} < T_{ref}$ and $n_{act} < 0.98 n_{ref}$ and $T_{ref} > T_{act} \geq (T_{ref} - 0.02 T_{maxmappedtorque})$	power and either torque or speed

Table 7.3: Permitted point deletions from regression analysis

## 8. MEASUREMENT PROCEDURES

### 8.1. Calibration and performance checks

#### 8.1.1. Introduction

This paragraph describes required calibrations and verifications of measurement systems. See paragraph 9.4. for specifications that apply to individual instruments.

Calibrations or verifications shall be generally performed over the complete measurement chain.

If a calibration or verification for a portion of a measurement system is not specified, that portion of the system shall be calibrated and its performance verified at a frequency consistent with any recommendations from the measurement system manufacturer and consistent with good engineering judgment.

Internationally recognized-traceable standards shall be used to meet the tolerances specified for calibrations and verifications.

## 8.1.2. Summary of calibration and verification

The table 8.1 summarizes the calibrations and verifications described in paragraph 8. and indicates when these have to be performed.

Type of calibration or verification	Minimum frequency <sup>(a)</sup>
8.1.3: accuracy, repeatability and noise	Accuracy: Not required, but recommended for initial installation. Repeatability: Not required, but recommended for initial installation. Noise: Not required, but recommended for initial installation.
8.1.4: linearity	Speed: Upon initial installation, within 370 days before testing and after major maintenance. Torque: Upon initial installation, within 370 days before testing and after major maintenance. Clean gas and diluted exhaust flows: Upon initial installation, within 370 days before testing and after major maintenance, unless flow is verified by propane check or by carbon or oxygen balance. Raw exhaust flow: Upon initial installation, within 185 days before testing and after major maintenance, unless flow is verified by propane check or by carbon or oxygen balance. Gas analyzers: Upon initial installation, within 35 days before testing and after major maintenance. PM balance: Upon initial installation, within 370 days before testing and after major maintenance. Stand-alone pressure and temperature: Upon initial installation, within 370 days before testing and after major maintenance.
8.1.5: Continuous gas analyzer system response and updating-recording verification – for gas analyzers not continuously compensated for other gas species	Upon initial installation or after system modification that would effect response.
8.1.6: Continuous gas analyzer system response and updating-recording verification – for gas analyzers continuously compensated for other gas species	Upon initial installation or after system modification that would effect response.
8.1.7.1: torque	Upon initial installation and after major maintenance.
8.1.7.2: pressure, temperature, dew point	Upon initial installation and after major maintenance.
8.1.8.1: fuel flow	Upon initial installation and after major maintenance.
8.1.8.2: intake flow	Upon initial installation and after major maintenance.
8.1.8.3: exhaust flow	Upon initial installation and after major maintenance.
8.1.8.4: diluted exhaust flow (CVS and PFD)	Upon initial installation and after major maintenance.
8.1.8.5: CVS/PFD and batch sampler verification <sup>(b)</sup>	Upon initial installation, within 35 days before testing, and after major maintenance. (Propane check)
8.1.8.8: vacuum leak	Before each laboratory test according to paragraph 7.1.
8.1.9.1: CO <sub>2</sub> NDIR H <sub>2</sub> O interference	Upon initial installation and after major maintenance.
8.1.9.2: CO NDIR CO <sub>2</sub> and H <sub>2</sub> O interference	Upon initial installation and after major maintenance.

Type of calibration or verification	Minimum frequency <sup>(a)</sup>
8.1.10.1: FID calibration THC FID optimization and THC FID verification	Calibrate, optimize, and determine CH <sub>4</sub> response: upon initial installation and after major maintenance. Verify CH <sub>4</sub> response: upon initial installation, within 185 days before testing, and after major maintenance.
8.1.10.2: raw exhaust FID O <sub>2</sub> interference	For all FID analyzers: upon initial installation, and after major maintenance. For THC FID analyzers: upon initial installation, after major maintenance, and after FID optimization according to 8.1.10.1.
8.1.10.3: non-methane cutter penetration	Upon initial installation, within 185 days before testing, and after major maintenance.
8.1.11.1: CLD CO <sub>2</sub> and H <sub>2</sub> O quench	Upon initial installation and after major maintenance.
8.1.11.3: NDUV HC and H <sub>2</sub> O interference	Upon initial installation and after major maintenance.
8.1.11.4: cooling bath NO <sub>2</sub> penetration (chiller)	Upon initial installation and after major maintenance.
8.1.11.5: NO <sub>2</sub> -to-NO converter conversion	Upon initial installation, within 35 days before testing, and after major maintenance.
8.1.12.1: PM balance and weighing	Independent verification: upon initial installation, within 370 days before testing, and after major maintenance. Zero, span, and reference sample verifications: within 12 hours of weighing, and after major maintenance.
<sup>(a)</sup> Perform calibrations and verifications more frequently, according to measurement system manufacturer instructions and good engineering judgment. <sup>(b)</sup> The CVS verification is not required for systems that agree within $\pm 2$ per cent based on a chemical balance of carbon or oxygen of the intake air, fuel, and diluted exhaust.	

Table 8.1 – Summary of Calibration and Verifications

### 8.1.3. Verifications for accuracy, repeatability, and noise

The performance values for individual instruments specified in table 9.3 are the basis for the determination of the accuracy, repeatability, and noise of an instrument.

It is not required to verify instrument accuracy, repeatability, or noise. However, it may be useful to consider these verifications to define a specification for a new instrument, to verify the performance of a new instrument upon delivery, or to troubleshoot an existing instrument.

### 8.1.4. Linearity check

#### 8.1.4.1. Scope and frequency

A linearity verification shall be performed on each measurement system listed in table 8.2 at least as frequently as indicated in the table, consistent with measurement system manufacturer recommendations and good engineering judgment. The intent of a linearity verification is to determine that a measurement system responds proportionally over the measurement range of interest. A linearity verification shall consist of introducing a series of at least 10 reference values to a measurement system, unless otherwise specified. The measurement system quantifies each reference value. The measured values shall be collectively compared to the reference values by using a least squares linear regression and the linearity criteria specified in table 8.2 of this paragraph.

#### 8.1.4.2. Performance requirements

If a measurement system does not meet the applicable linearity criteria in table 8.2, the deficiency shall be corrected by re-calibrating, servicing, or replacing components as needed. The linearity verification shall be repeated after correcting the deficiency to ensure that the measurement system meets the linearity criteria.

#### 8.1.4.3. Procedure

The following linearity verification protocol shall be used:

- (a) A measurement system shall be operated at its specified temperatures, pressures, and flows.
- (b) The instrument shall be zeroed as it would before an emission test by introducing a zero signal. For gas analyzers, a zero gas shall be used that meets the specifications of paragraph 9.5.1. and it shall be introduced directly at the analyzer port.
- (c) The instrument shall be spanned as it would before an emission test by introducing a span signal. For gas analyzers, a span gas shall be used that meets the specifications of paragraph 9.5.1. and it shall be introduced directly at the analyzer port.
- (d) After spanning the instrument, zero shall be checked with the same signal which has been used in paragraph (b) of this paragraph. Based on the zero

- reading, good engineering judgment shall be used to determine whether or not to re-zero and or re-span the instrument before proceeding to the next step.
- (e) For all measured quantities manufacturer recommendations and good engineering judgment shall be used to select the reference values,  $y_{\text{ref}i}$ , that cover the full range of values that are expected during emission testing, thus avoiding the need of extrapolation beyond these values. A zero reference signal shall be selected as one of the reference values of the linearity verification. For stand-alone pressure and temperature linearity verifications, at least three reference values shall be selected. For all other linearity verifications, at least ten reference values shall be selected.
  - (f) Instrument manufacturer recommendations and good engineering judgment shall be used to select the order in which the series of reference values will be introduced.
  - (g) Reference quantities shall be generated and introduced as described in paragraph 8.1.4.4. For gas analyzers, gas concentrations known to be within the specifications of paragraph 9.5.1. shall be used and they shall be introduced directly at the analyzer port.
  - (h) Time for the instrument to stabilize while it measures the reference value shall be allowed.
  - (i) At the minimum recording frequency, as specified in table 9.2, the reference value shall be measured for 30 s and the arithmetic mean of the recorded values,  $\bar{y}_i$  recorded.
  - (j) Steps in paragraphs (f) through (h) of this paragraph shall be repeated until all reference quantities are measured.
  - (k) The arithmetic means  $\bar{y}_i$ , and reference values,  $y_{\text{ref}i}$ , shall be used to calculate least-squares linear regression parameters and statistical values to compare to the minimum performance criteria specified in table 8.2. The calculations described in Annex A.2.2. shall be used.

#### 8.1.4.4. Reference signals

This paragraph describes recommended methods for generating reference values for the linearity-verification protocol in paragraph 8.1.4.3. of this section. Reference values shall be used that simulate actual values, or an actual value shall be introduced and measured with a reference-measurement system. In the latter case, the reference value is the value reported by the reference-measurement system. Reference values and reference-measurement systems shall be internationally traceable.

For temperature measurement systems with sensors like thermocouples, RTDs, and thermistors, the linearity verification may be performed by removing the sensor from the system and using a simulator in its place. A simulator that is independently calibrated and cold junction compensated, as necessary shall be used. The internationally traceable simulator uncertainty scaled to temperature shall be less than 0.5 per cent of maximum operating temperature  $T_{\text{max}}$ . If this option is used, it is necessary to use sensors that the supplier states are accurate to better than 0.5 per cent of  $T_{\text{max}}$  compared to their standard calibration curve.

#### 8.1.4.5. Measurement systems that require linearity verification

Table 8.2 indicates measurement systems that require linearity verifications. For this table the following provisions apply.

- (a) A linearity verification shall be performed more frequently if the instrument manufacturer recommends it or based on good engineering judgment.
- (b) "min" refers to the minimum reference value used during the linearity verification.  
Note that this value may be zero or a negative value depending on the signal.
- (c) "max" generally refers to the maximum reference value used during the linearity verification. For example for gas dividers,  $x_{\max}$  is the undivided, undiluted, span gas concentration. The following are special cases where "max" refers to a different value:
  - (i) For PM balance linearity verification,  $m_{\max}$  refers to the typical mass of a PM filter.
  - (ii) For torque linearity verification,  $T_{\max}$  refers to the manufacturer's specified engine torque peak value of the highest torque engine to be tested.
- (d) The specified ranges are inclusive. For example, a specified range of 0.98-1.02 for the slope  $a_1$  means  $0.98 \leq a_1 \leq 1.02$ .
- (e) These linearity verifications are not required for systems that pass the flow-rate verification for diluted exhaust as described 8.1.8.5. for the propane check or for systems that agree within  $\pm 2$  per cent based on a chemical balance of carbon or oxygen of the intake air, fuel, and exhaust.
- (f)  $a_1$  criteria for these quantities shall be met only if the absolute value of the quantity is required, as opposed to a signal that is only linearly proportional to the actual value.
- (g) Stand-alone temperatures include engine temperatures and ambient conditions used to set or verify engine conditions; temperatures used to set or verify critical conditions in the test system; and temperatures used in emissions calculations:
  - (i) These temperature linearity checks are required. Air intake; aftertreatment bed(s) (for engines tested with aftertreatment devices on cycles with cold start criteria); dilution air for PM sampling (CVS, double dilution, and partial flow systems); PM sample; and chiller sample (for gaseous sampling systems that use chillers to dry samples).
  - (ii) These temperature linearity checks are only required if specified by the engine manufacturer. Fuel inlet; test cell charge air cooler air outlet (for engines tested with a test cell heat exchanger simulating a vehicle/machine charge air cooler); test cell charge air cooler coolant inlet (for engines tested with a test cell heat exchanger simulating a vehicle/machine charge air cooler); and oil in the sump/pan; coolant before the thermostat (for liquid cooled engines).
- (h) Stand-alone pressures include engine pressures and ambient conditions used to set or verify engine conditions; pressures used to set or verify critical conditions in the test system; and pressures used in emissions calculations:



- (i) Required pressure linearity checks are: air intake restriction; exhaust back pressure; barometer; CVS inlet gage pressure (if measurement using CVS); chiller sample (for gaseous sampling systems that use chillers to dry samples).
- (ii) Pressure linearity checks that are required only if specified by the engine manufacturer: test cell charge air cooler and interconnecting pipe pressure drop (for turbo-charged engines tested with a test cell heat exchanger simulating a vehicle/machine charge air cooler) fuel inlet; and fuel outlet.

Measurement System	Quantity	Minimum verification frequency	Linearity Criteria			
			$ x_{\min} * (a_1 - 1) + a_0 $	$a$	$SEE$	$r^2$
Engine speed	$n$	Within 370 days before testing	$\leq 0.05 \% n_{\max}$	0.98-1.02	$\leq 2 \% n_{\max}$	$\geq 0.990$
Engine torque	$T$	Within 370 days before testing	$\leq 1 \% T_{\max}$	0.98-1.02	$\leq 2 \% T_{\max}$	$\geq 0.990$
Fuel flow rate	$q_m$	Within 370 days before testing	$\leq 1 \% q_{m, \max}$	0.98-1.02	$\leq 2 \% q_{m, \max}$	$\geq 0.990$
Intake-air flow rate	$q^V$	Within 370 days before testing	$\leq 1 \% q^V_{, \max}$	0.98-1.02	$\leq 2 \% q^V_{, \max}$	$\geq 0.990$
Dilution air flow rate	$q^V$	Within 370 days before testing	$\leq 1 \% q^V_{, \max}$	0.98-1.02	$\leq 2 \% q^V_{, \max}$	$\geq 0.990$
Diluted exhaust flow rate	$q^V$	Within 370 days before testing	$\leq 1 \% q^V_{, \max}$	0.98-1.02	$\leq 2 \% q^V_{, \max}$	$\geq 0.990$
Raw exhaust flow rate	$q^V$	Within 185 days before testing	$\leq 1 \% q^V_{, \max}$	0.98-1.02	$\leq 2 \% q^V_{, \max}$	$\geq 0.990$
Batch sampler flow rates	$q^V$	Within 370 days before testing	$\leq 1 \% q^V_{, \max}$	0.98-1.02	$\leq 2 \% q^V_{, \max}$	$\geq 0.990$
Gas dividers	$x/x_{\text{span}}$	Within 370 days before testing	$\leq 0.5 \% x_{\max}$	0.98-1.02	$\leq 2 \% x_{\max}$	$\geq 0.990$
Gas analyzers	$x$	Within 35 days before testing	$\leq 0.5 \% x_{\max}$	0.99-1.01	$\leq 1 \% x_{\max}$	$\geq 0.998$
PM balance	$m$	Within 370 days before testing	$\leq 1 \% m_{\max}$	0.99-1.01	$\leq 1 \% m_{\max}$	$\geq 0.998$
Stand-alone pressures	$p$	Within 370 days before testing	$\leq 1 \% p_{\max}$	0.99-1.01	$\leq 1 \% p_{\max}$	$\geq 0.998$
Analog-to-digital conversion of stand-alone temperature signals	$T$	Within 370 days before testing	$\leq 1 \% T_{\max}$	0.99-1.01	$\leq 1 \% T_{\max}$	$\geq 0.998$

Table 8.2. – Measurement systems that require linearity verifications

#### 8.1.5. Continuous gas analyser system-response and updating-recording verification

This section describes a general verification procedure for continuous gas analyzer system response and update recording. See paragraph 8.1.6. for verification procedures for compensation type analysers.

##### 8.1.5.1. Scope and frequency

This verification shall be performed after installing or replacing a gas analyzer that is used for continuous sampling. Also this verification shall be performed if the system is reconfigured in a way that would change system response. This verification is needed for continuous gas analysers used for transient or ramped-modal testing but is not needed for batch gas analyzer systems or for continuous gas analyzer systems used only for discrete-mode testing.

##### 8.1.5.2. Measurement principles

This test verifies that the updating and recording frequencies match the overall system response to a rapid change in the value of concentrations at the sample probe. Gas analyzer systems shall be optimized such that their overall response to a rapid change in concentration is updated and recorded at an appropriate frequency to prevent loss of information. This test also verifies that continuous gas analyzer systems meet a minimum response time.

The system settings for the response time evaluation shall be exactly the same as during measurement of the test run (i.e. pressure, flow rates, filter settings on the analyzers and all other response time influences). The response time determination shall be done with gas switching directly at the inlet of the sample probe. The devices for gas switching shall have a specification to perform the switching in less than 0.1 s. The gases used for the test shall cause a concentration change of at least 60 per cent full scale (FS).

The concentration trace of each single gas component shall be recorded.

##### 8.1.5.3. System requirements

- (a) The system response time shall be  $\leq 10$  s with a rise time of  $\leq 2.5$  s or with a rise and fall time of  $\leq 5$  s each for all measured components (CO, NO<sub>x</sub>, CO<sub>2</sub> and HC) and all ranges used. When using a NMC for the measurement of NMHC, the system response time may exceed 10 s.

All data (concentration, fuel and air flows) have to be shifted by their measured response times before performing the emission calculations given in Annexes A.7-A.8.

- (b) To demonstrate acceptable updating and recording with respect to the system's overall response, the system shall meet one of the following criteria:

- (i) The product of the mean rise time and the frequency at which the system records an updated concentration shall be at least 5. In any case the mean rise time shall be no more than 10 s.
- (ii) The frequency at which the system records the concentration shall be at least 2 Hz (see also table 9.2).

#### 8.1.5.4. Procedure

The following procedure shall be used to verify the response of each continuous gas analyzer system:

- (a) The analyzer system manufacturer's start-up and operating instructions for the instrument setup shall be followed. The measurement system shall be adjusted as needed to optimize performance. This verification shall be run with the analyzer operating in the same manner as used for emission testing. If the analyzer shares its sampling system with other analyzers, and if gas flow to the other analyzers will affect the system response time, then the other analyzers shall be started up and operated while running this verification test. This verification test may be run on multiple analyzers sharing the same sampling system at the same time. If analogue or real-time digital filters are used during emission testing, those filters shall be operated in the same manner during this verification.
- (b) For equipment used to validate system response time, minimal gas transfer line lengths between all connections are recommended to be used, a zero-air source shall be connected to one inlet of a fast-acting 3-way valve (2 inlets, 1 outlet) in order to control the flow of zero and blended span gases to the sample system's probe inlet or a tee near the outlet of the probe. Normally the gas flow rate is higher than the probe sample flow rate and the excess is overflowed out the inlet of the probe. If the gas flow rate is lower than the probe flow rate, the gas concentrations shall be adjusted to account for the dilution from ambient air drawn into the probe. Binary or multi-gas span gases may be used. A gas blending or mixing device may be used to blend span gases. A gas blending or mixing device is recommended when blending span gases diluted in N<sub>2</sub> with span gases diluted in air.

Using a gas divider, an NO-CO-CO<sub>2</sub>-C<sub>3</sub>H<sub>8</sub>-CH<sub>4</sub> (balance N<sub>2</sub>) span gas shall be equally blended with a span gas of NO<sub>2</sub>, balance purified synthetic air. Standard binary span gases may be also be used, where applicable, in place of blended NO-CO-CO<sub>2</sub>-C<sub>3</sub>H<sub>8</sub>-CH<sub>4</sub>, balance N<sub>2</sub> span gas; in this case separate response tests shall be run for each analyzer. The gas divider outlet shall be connected to the other inlet of the 3-way valve. The valve outlet shall be connected to an overflow at the gas analyzer system's probe or to an overflow fitting between the probe and transfer line to all the analyzers being verified. A setup that avoids pressure pulsations due to stopping the flow through the gas blending device shall be used. Any of these gas constituents if they are not relevant to the analyzers for this verification shall be omitted. Alternatively the use of gas bottles with single gases and a separate measurement of response times is allowed.

- (c) Data collection shall be done as follows:
  - (i) The valve shall be switched to start the flow of zero gas.
  - (ii) Stabilization shall be allowed for, accounting for transport delays and the slowest analyzer's full response.
  - (iii) Data recording shall be started at the frequency used during emission testing. Each recorded value shall be a unique updated concentration measured by the analyzer; interpolation or filtering may not be used to alter recorded values.
  - (iv) The valve shall be switched to allow the blended span gases to flow to the analyzers. This time shall be recorded as  $t_0$ .
  - (v) Transport delays and the slowest analyzer's full response shall be allowed for.
  - (vi) The flow shall be switched to allow zero gas to flow to the analyzer. This time shall be recorded as  $t_{100}$ .
  - (vii) Transport delays and the slowest analyzer's full response shall be allowed for.
  - (viii) The steps in paragraphs (c)(iv) through (vii) of this paragraph shall be repeated to record seven full cycles, ending with zero gas flowing to the analyzers.
  - (ix) Recording shall be stopped.

#### 8.1.5.5. Performance evaluation

The data from paragraph 8.1.5.4.(c) of this section shall be used to calculate the mean rise time,  $T_{10-90}$  for each of the analyzers.

- (a) If it is chosen to demonstrate compliance with paragraph 8.1.5.3.(b)(i) of this section the following procedure has to be applied: The rise times (in s) shall be multiplied by their respective recording frequencies in Hertz (1/s). The value for each result shall be at least 5. If the value is less than 5, the recording frequency shall be increased or the flows adjusted or the design of the sampling system shall be changed to increase the rise time as needed. Also digital filters may be configured to increase rise time.
- (b) If it is chosen to demonstrate compliance with paragraph 8.1.5.3.(b)(ii) of this section, the demonstration of compliance with the requirements of paragraph 8.1.5.3.(b) (ii) is sufficient.

#### 8.1.6. Response time verification for compensation type analysers

##### 8.1.6.1. Scope and frequency

This verification shall be performed to determine a continuous gas analyzer's response, where one analyzer's response is compensated by another's to quantify a gaseous emission. For this check water vapour shall be considered to be a gaseous constituent. This verification is required for continuous gas analyzers used for transient or ramped-modal testing. This verification is not needed for batch gas analyzers or for continuous gas analyzers that are used only for discrete-mode testing. This verification does not apply to correction for water removed from the

sample done in post-processing and it does not apply to NMHC determination from THC and CH<sub>4</sub> quoted in Annexes A.7. and A.8. concerning the emission calculations. This verification shall be performed after initial installation (i.e. test cell commissioning). After major maintenance, paragraph 8.1.5. may be used to verify uniform response provided that any replaced components have gone through a humidified uniform response verification at some point.

#### 8.1.6.2. Measurement principles

This procedure verifies the time-alignment and uniform response of continuously combined gas measurements. For this procedure, it is necessary to ensure that all compensation algorithms and humidity corrections are turned on.

#### 8.1.6.3. System requirements

The general response time and rise time requirement given in 8.1.5.3 (a) is also valid for compensation type analysers. Additionally, if the recording frequency is different than the update frequency of the continuously combined/compensated signal, the lower of these two frequencies shall be used for the verification required by paragraph 8.1.5.3(b)(i).

#### 8.1.6.4. Procedure

All procedures given in paragraph 8.1.5.4.(a) – (c) have to be used. Additionally also the response and rise time of water vapour has to be measured, if a compensation algorithm based on measured water vapour is used. In this case at least one of the used calibration gases (but not NO<sub>2</sub>) has to be humidified as follows:

If the system does not use a sample dryer to remove water from the sample gas, the span gas shall be humidified by flowing the gas mixture through a sealed vessel that humidifies the gas to the highest sample dew point that is estimated during emission sampling by bubbling it through distilled water. If the system uses a sample dryer during testing that has passed the sample dryer verification check, the humidified gas mixture may be introduced downstream of the sample dryer by bubbling it through distilled water in a sealed vessel at (25 ±10 °C), or a temperature greater than the dew point. In all cases, downstream of the vessel, the humidified gas shall be maintained at a temperature of at least 5 °C above its local dew point in the line. Note that it is possible to omit any of these gas constituents if they are not relevant to the analyzers for this verification. If any of the gas constituents are not susceptible to water compensation, the response check for these analyzers may be performed without humidification.

#### 8.1.7. Measurement of engine parameters and ambient conditions

The engine manufacturer shall apply internal quality procedures traceable to recognised national or international standards. Otherwise the following procedures apply.

8.1.7.1. Torque calibration

8.1.7.1.1. Scope and frequency

All torque-measurement systems including dynamometer torque measurement transducers and systems shall be calibrated upon initial installation and after major maintenance using, among others, reference force or lever-arm length coupled with dead weight. Good engineering judgment shall be used to repeat the calibration. The torque transducer manufacturer's instructions shall be followed for linearizing the torque sensor's output. Other calibration methods are permitted.

8.1.7.1.2. Dead-weight calibration

This technique applies a known force by hanging known weights at a known distance along a lever arm. It shall be made sure that the weights' lever arm is perpendicular to gravity (i.e., horizontal) and perpendicular to the dynamometer's rotational axis. At least six calibration-weight combinations shall be applied for each applicable torque-measuring range, spacing the weight quantities about equally over the range. The dynamometer shall be oscillated or rotated during calibration to reduce frictional static hysteresis. Each weight's force shall be determined by multiplying its internationally-traceable mass by the local acceleration of Earth's gravity.

8.1.7.1.3. Strain gage or proving ring calibration

This technique applies force either by hanging weights on a lever arm (these weights and their lever arm length are not used as part of the reference torque determination) or by operating the dynamometer at different torques. At least six force combinations shall be applied for each applicable torque-measuring range, spacing the force quantities about equally over the range. The dynamometer shall be oscillated or rotated during calibration to reduce frictional static hysteresis. In this case, the reference torque is determined by multiplying the force output from the reference meter (such as a strain gage or proving ring) by its effective lever-arm length, which is measured from the point where the force measurement is made to the dynamometer's rotational axis. It shall be made sure that this length is measured perpendicular to the reference meter's measurement axis and perpendicular to the dynamometer's rotational axis.

8.1.7.2. Pressure, temperature, and dew point calibration

Instruments shall be calibrated for measuring pressure, temperature, and dew point upon initial installation. The instrument manufacturer's instructions shall be followed and good engineering judgment shall be used to repeat the calibration.

For temperature measurement systems with thermocouple, RTD, or thermistor sensors, the calibration of the system shall be performed as described in paragraph 8.1.4.4. for linearity verification.

8.1.8. Flow-related measurements

8.1.8.1. Fuel flow calibration

Fuel flow meters shall be calibrated upon initial installation. The instrument manufacturer's instructions shall be followed and good engineering judgment shall be used to repeat the calibration.

8.1.8.2. Intake air flow calibration

Intake air flow meters shall be calibrated upon initial installation. The instrument manufacturer's instructions shall be followed and good engineering judgment shall be used to repeat the calibration.

8.1.8.3. Exhaust flow calibration

Exhaust flow meters shall be calibrated upon initial installation. The instrument manufacturer's instructions shall be followed and good engineering judgment shall be used to repeat the calibration.

8.1.8.4. Diluted exhaust flow (CVS) calibration

8.1.8.4.1. Overview

- (a) This section describes how to calibrate flow meters for diluted exhaust constant-volume sampling (CVS) systems.
- (b) This calibration shall be performed while the flow meter is installed in its permanent position. This calibration shall be performed after any part of the flow configuration upstream or downstream of the flow meter has been changed that may affect the flow-meter calibration. This calibration shall be performed upon initial CVS installation and whenever corrective action does not resolve a failure to meet the diluted exhaust flow verification (*i.e.*, propane check) in paragraph 8.1.8.5.
- (c) A CVS flow meter shall be calibrated using a reference flow meter such as a subsonic venturi flow meter, a long-radius flow nozzle, a smooth approach orifice, a laminar flow element, a set of critical flow venturis, or an ultrasonic flow meter. A reference flow meter shall be used that reports quantities that are internationally-traceable within  $\pm 1$  per cent uncertainty. This reference flow meter's response to flow shall be used as the reference value for CVS flow-meter calibration.
- (d) An upstream screen or other restriction that could affect the flow ahead of the reference flow meter may not be used, unless the flow meter has been calibrated with such a restriction.
- (e) The calibration sequence described under this paragraph 8.1.8.4. refers to the molar based approach. For the corresponding sequence used in the mass based approach, see Annex 8 Appendix 1.

## 8.1.8.4.2. PDP calibration

A positive-displacement pump (PDP) shall be calibrated to determine a flow-versus-PDP speed equation that accounts for flow leakage across sealing surfaces in the PDP as a function of PDP inlet pressure. Unique equation coefficients shall be determined for each speed at which the PDP is operated. A PDP flow meter shall be calibrated as follows:

- (a) The system shall be connected as shown in figure 8.1.
- (b) Leaks between the calibration flow meter and the PDP shall be less than 0.3 per cent of the total flow at the lowest calibrated flow point; for example, at the highest restriction and lowest PDP-speed point.
- (c) While the PDP operates, a constant temperature at the PDP inlet shall be maintained within  $\pm 2$  per cent of the mean absolute inlet temperature,  $T_{in}$ .
- (d) The PDP speed is set to the first speed point at which it is intended to calibrate.
- (e) The variable restrictor is set to its wide-open position.
- (f) The PDP is operated for at least 3 min to stabilize the system. Then by continuously operating the PDP, the mean values of at least 30 s of sampled data of each of the following quantities are recorded:
  - (i) The mean flow rate of the reference flow meter,  $\bar{n}_{ref}$
  - (ii) The mean temperature at the PDP inlet,  $T_{in}$
  - (iii) The mean static absolute pressure at the PDP inlet,  $p_{in}$
  - (iv) The mean static absolute pressure at the PDP outlet,  $p_{out}$
  - (v) The mean PDP speed,  $n_{PDP}$ .
- (g) The restrictor valve shall be incrementally closed to decrease the absolute pressure at the inlet to the PDP,  $p_{in}$ .
- (h) The steps in paragraphs (8.1.8.4.2.) (f) and (g) of this section shall be repeated to record data at a minimum of six restrictor positions reflecting the full range of possible in-use pressures at the PDP inlet.
- (i) The PDP shall be calibrated by using the collected data and the equations in Annexes A.7-A.8.
- (j) The steps in paragraphs (f) through (i) of this section shall be repeated for each speed at which the PDP is operated.
- (k) The equations in Annex A.7 (molar based approach) or A.8 (mass based approach) shall be used to determine the PDP flow equation for emission testing.
- (l) The calibration shall be verified by performing a CVS verification (*i.e.*, propane check) as described in paragraph 8.1.8.5.
- (m) The PDP may not be used below the lowest inlet pressure tested during calibration.

## 8.1.8.4.3. CFV calibration

A critical-flow venturi (CFV) shall be calibrated to verify its discharge coefficient,  $C_d$ , at the lowest expected static differential pressure between the CFV inlet and outlet. A CFV flow meter shall be calibrated as follows:

- (a) The system shall be connected as shown in figure 8.1.
- (b) The blower shall be started downstream of the CFV.



- (c) While the CFV operates, a constant temperature at the CFV inlet shall be maintained within  $\pm 2$  per cent of the mean absolute inlet temperature,  $T_{in}$ .
- (d) Leaks between the calibration flow meter and the CFV shall be less than 0.3 per cent of the total flow at the highest restriction.
- (e) The variable restrictor shall be set to its wide-open position. In lieu of a variable restrictor the pressure downstream of the CFV may be varied by varying blower speed or by introducing a controlled leak. Note that some blowers have limitations on non-loaded conditions.
- (f) The CFV shall be operated for at least 3 min to stabilize the system. The CFV shall continue operating and the mean values of at least 30 s of sampled data of each of the following quantities shall be recorded:
  - (i) The mean flow rate of the reference flow meter,  $\bar{n}_{ref}$ .
  - (ii) Optionally, the mean dew point of the calibration air,  $T_{dew}$ . See Annexes A.7-A.8 for permissible assumptions during emission measurements.
  - (iii) The mean temperature at the venturi inlet,  $T_{in}$ .
  - (iv) The mean static absolute pressure at the venturi inlet,  $p_{in}$ .
  - (v) The mean static differential pressure between the CFV inlet and the CFV outlet,  $\Delta p_{CFV}$ .
- (g) The restrictor valve shall be incrementally closed to decrease the absolute pressure at the inlet to the CFV,  $p_{in}$ .
- (h) The steps in paragraphs (f) and (g) of this paragraph shall be repeated to record mean data at a minimum of ten restrictor positions, such that the fullest practical range of  $\Delta p_{CFV}$  expected during testing is tested. It is not required to remove calibration components or CVS components to calibrate at the lowest possible restrictions.
- (i)  $C_d$  and the lowest allowable pressure ratio  $r$  shall be determined as described in Annexes A.7-A.8.
- (j)  $C_d$  shall be used to determine CFV flow during an emission test. The CFV shall not be used below the lowest allowed  $r$ , as determined in Annexes A.7-A.8.
- (k) The calibration shall be verified by performing a CVS verification (*i.e.*, propane check) as described in paragraph 8.1.8.5.
- (l) If the CVS is configured to operate more than one CFV at a time in parallel, the CVS shall be calibrated by one of the following:
  - (i) Every combination of CFVs shall be calibrated according to this paragraph and Annexes A.7-A.8. See Annexes A.7-A.8 for instructions on calculating flow rates for this option.
  - (ii) Each CFV shall be calibrated according to this paragraph and Annexes A.7-A.8. See Annexes A.7-A.8 for instructions on calculating flow rates for this option.

#### 8.1.8.4.4. SSV calibration

A subsonic venturi (SSV) shall be calibrated to determine its calibration coefficient,  $C_d$ , for the expected range of inlet pressures. An SSV flow meter shall be calibrated as follows:

- (a) The system shall be connected as shown in figure 8.1.
- (b) The blower shall be started downstream of the SSV.
- (c) Leaks between the calibration flow meter and the SSV shall be less than 0.3 per cent of the total flow at the highest restriction.
- (d) While the SSV operates, a constant temperature at the SSV inlet shall be maintained within  $\pm 2$  per cent of the mean absolute inlet temperature,  $T_{in}$ .
- (e) The variable restrictor or variable-speed blower shall be set to a flow rate greater than the greatest flow rate expected during testing. Flow rates may not be extrapolated beyond calibrated values, so it is recommended that it is made certain that a Reynolds number,  $Re$ , at the SSV throat at the greatest calibrated flow rate is greater than the maximum  $Re$  expected during testing.
- (f) The SSV shall be operated for at least 3 min to stabilize the system. The SSV shall continue operating and the mean of at least 30 s of sampled data of each of the following quantities shall be recorded:
  - (i) The mean flow rate of the reference flow meter,  $\bar{q}_{Vref}$ .
  - (ii) Optionally, the mean dew point of the calibration air,  $T_{dew}$ . See Annexes A.7-A.8 for permissible assumptions.
  - (iii) The mean temperature at the venturi inlet,  $T_{in}$ .
  - (iv) The mean static absolute pressure at the venturi inlet,  $p_{in}$ .
  - (v) Static differential pressure between the static pressure at the venturi inlet and the static pressure at the venturi throat,  $\Delta p_{SSV}$ .
- (g) The restrictor valve shall be incrementally closed or the blower speed decreased to decrease the flow rate.
- (h) The steps in paragraphs (f) and (g) of this paragraph shall be repeated to record data at a minimum of ten flow rates.
- (i) A functional form of  $C_d$  versus  $Re$  shall be determined by using the collected data and the equations in Annexes A.7-A.8.
- (j) The calibration shall be verified by performing a CVS verification (*i.e.*, propane check) as described in paragraph 8.1.8.5 using the new  $C_d$  versus  $Re$  equation.
- (k) The SSV shall be used only between the minimum and maximum calibrated flow rates.
- (l) The equations in Annex A.7 (molar based approach) or Annex A.8 (mass based approach) shall be used to determine SSV flow during a test.

#### 8.1.8.4.5. Ultrasonic calibration (reserved)

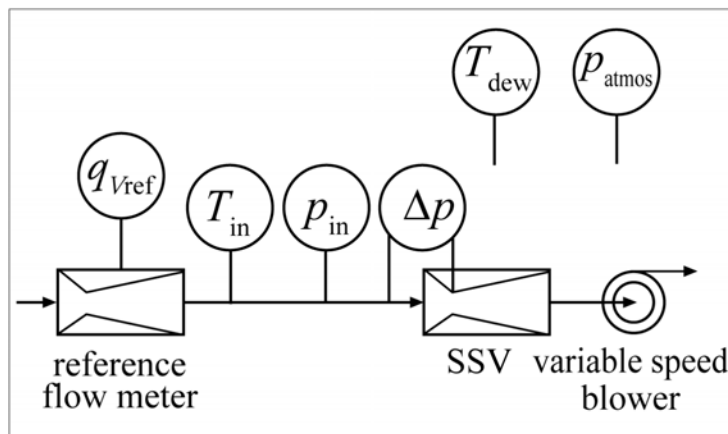
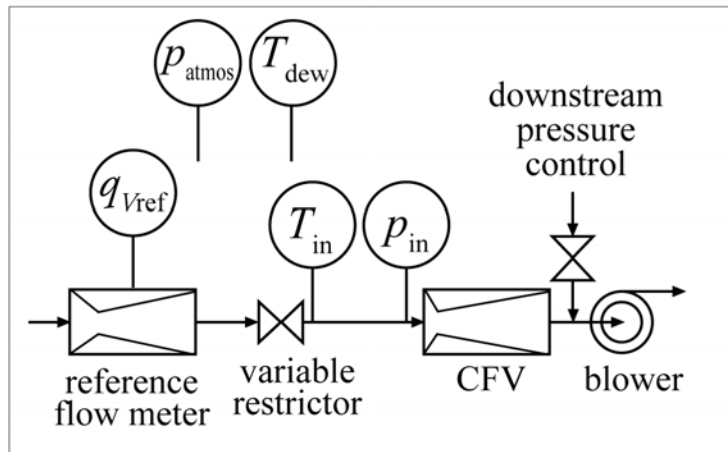
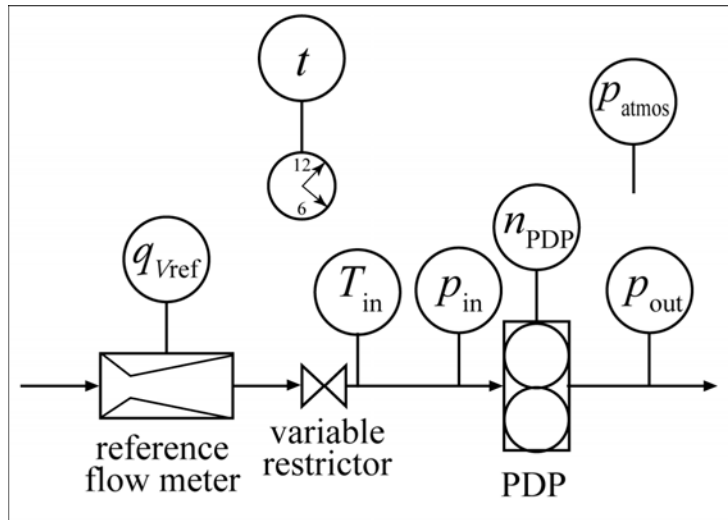

Figure 8.1 – Schematic diagrams for diluted exhaust flow CVS calibration

## 8.1.8.5. CVS and batch sampler verification (propane check)

## 8.1.8.5.1. Introduction

- (a) A propane check serves as a CVS verification to determine if there is a discrepancy in measured values of diluted exhaust flow. A propane check also serves as a batch-sampler verification to determine if there is a discrepancy in a batch sampling system that extracts a sample from a CVS, as described in paragraph (f) of this paragraph. Using good engineering judgment and safe practices, this check may be performed using a gas other than propane, such as CO<sub>2</sub> or CO. A failed propane check might indicate one or more problems that may require corrective action, as follows:
- (i) Incorrect analyzer calibration. The FID analyzer shall be re-calibrated, repaired, or replaced.
  - (ii) Leak checks shall be performed on CVS tunnel, connections, fasteners, and HC sampling system according to paragraph 8.1.8.7.
  - (iii) The verification for poor mixing shall be performed in accordance with paragraph 9.2.2.
  - (iv) The hydrocarbon contamination verification in the sample system shall be performed as described in paragraph 7.3.1.3.
  - (v) Change in CVS calibration. An in-situ calibration of the CVS flow meter shall be performed as described in paragraph 8.1.8.4.
  - (vi) Other problems with the CVS or sampling verification hardware or software. The CVS system, CVS verification hardware, and software shall be inspected for discrepancies.
- (b) A propane check uses either a reference mass or a reference flow rate of C<sub>3</sub>H<sub>8</sub> as a tracer gas in a CVS. If a reference flow rate is used, any non-ideal gas behaviour of C<sub>3</sub>H<sub>8</sub> in the reference flow meter shall be accounted for. See Annexes A.7. (molar based approach) or A.8. (mass based approach), which describe how to calibrate and use certain flow meters. No ideal gas assumption may be used in paragraph 8.1.8.5. and Annexes A.7. or A.8. The propane check compares the calculated mass of injected C<sub>3</sub>H<sub>8</sub> using HC measurements and CVS flow rate measurements with the reference value.

## 8.1.8.5.2. Method of introducing a known amount of propane into the CVS system

The total accuracy of the CVS sampling system and analytical system shall be determined by introducing a known mass of a pollutant gas into the system while it is being operated in the normal manner. The pollutant is analyzed, and the mass calculated according to Annexes A.7-A.8. Either of the following two techniques shall be used.

- (a) Metering by means of a gravimetric technique shall be done as follows: A mass of a small cylinder filled with carbon monoxide or propane shall be determined with a precision of ±0.01 g. For about 5 to 10 minutes, the CVS system shall be operated as in a normal exhaust emission test, while carbon monoxide or propane is injected into the system. The quantity of pure gas discharged shall be determined by means of differential weighing. A gas sample shall be

analyzed with the usual equipment (sampling bag or integrating method), and the mass of the gas calculated.

- (b) Metering with a critical flow orifice shall be done as follows: A known quantity of pure gas (carbon monoxide or propane) shall be fed into the CVS system through a calibrated critical orifice. If the inlet pressure is high enough, the flow rate, which is adjusted by means of the critical flow orifice, is independent of the orifice outlet pressure (critical flow). The CVS system shall be operated as in a normal exhaust emission test for about 5 to 10 minutes. A gas sample shall be analyzed with the usual equipment (sampling bag or integrating method), and the mass of the gas calculated.

#### 8.1.8.5.3. Preparation of the propane check

The propane check shall be prepared as follows:

- (a) If a reference mass of  $C_3H_8$  is used instead of a reference flow rate, a cylinder charged with  $C_3H_8$  shall be obtained. The reference cylinder's mass of  $C_3H_8$  shall be determined within  $\pm 0.5$  per cent of the amount of  $C_3H_8$  that is expected to be used.
- (b) Appropriate flow rates shall be selected for the CVS and  $C_3H_8$ .
- (c) A  $C_3H_8$  injection port shall be selected in the CVS. The port location shall be selected to be as close as practical to the location where engine exhaust is introduced into the CVS. The  $C_3H_8$  cylinder shall be connected to the injection system.
- (d) The CVS shall be operated and stabilized.
- (e) Any heat exchangers in the sampling system shall be pre-heated or pre-cooled.
- (f) Heated and cooled components such as sample lines, filters, chillers, and pumps shall be allowed to stabilize at operating temperature.
- (g) If applicable, a vacuum side leak verification of the HC sampling system shall be performed as described in 8.1.8.7.

#### 8.1.8.5.4. Preparation of the HC sampling system for the propane check

Vacuum side leak check verification of the HC sampling system may be performed according to (g) of this paragraph. If this procedure is used, the HC contamination procedure in paragraph 7.3.1.3. may be used. If the vacuum side leak check is not performed according to (g), then the HC sampling system shall be zeroed, spanned, and verified for contamination, as follows:

- (a) The lowest HC analyzer range that can measure the  $C_3H_8$  concentration expected for the CVS and  $C_3H_8$  flow rates shall be selected.
- (b) The HC analyzer shall be zeroed using zero air introduced at the analyzer port.
- (c) The HC analyzer shall be spanned using  $C_3H_8$  span gas introduced at the analyzer port.
- (d) Zero air shall be overflowed at the HC probe or into a fitting between the HC probe and the transfer line.
- (e) The stable HC concentration of the HC sampling system shall be measured as overflow zero air flows. For batch HC measurement, the batch container (such as a bag) shall be filled and the HC overflow concentration measured.
- (f) If the overflow HC concentration exceeds  $2 \mu\text{mol/mol}$ , the procedure may not be advanced until contamination is eliminated. The source of the

contamination shall be determined and corrective action taken, such as cleaning the system or replacing contaminated portions.

- (g) When the overflow HC concentration does not exceed  $2 \mu\text{mol/mol}$ , this value shall be recorded as  $x_{\text{HCinit}}$  and it shall be used to correct for HC contamination as described in Annex A.7. (molar based approach) or Annex A.8. (mass based approach).

#### 8.1.8.5.5. Propane check performance

- (a) The propane check shall be performed as follows:
- (i) For batch HC sampling, clean storage media, such as evacuated bags shall be connected.
  - (ii) HC measurement instruments shall be operated according to the instrument manufacturer's instructions.
  - (iii) If correction for dilution air background concentrations of HC is foreseen, background HC in the dilution air shall be measured and recorded.
  - (iv) Any integrating devices shall be zeroed.
  - (v) Sampling shall begin and any flow integrators shall be started.
  - (vi)  $\text{C}_3\text{H}_8$  shall be released at the rate selected. If a reference flow rate of  $\text{C}_3\text{H}_8$  is used, the integration of this flow rate shall be started.
  - (vii)  $\text{C}_3\text{H}_8$  shall be continued to be released until at least enough  $\text{C}_3\text{H}_8$  has been released to ensure accurate quantification of the reference  $\text{C}_3\text{H}_8$  and the measured  $\text{C}_3\text{H}_8$ .
  - (viii) The  $\text{C}_3\text{H}_8$  cylinder shall be shut off and sampling shall continue until it has been accounted for time delays due to sample transport and analyzer response.
  - (ix) Sampling shall be stopped and any integrators shall be stopped.
- (b) In case the metering with a critical flow orifice is used, the following procedure may be used for the propane check as the alternative method of paragraph 8.1.8.5.5.(a)
- (i) For batch HC sampling, clean storage media, such as evacuated bags shall be connected.
  - (ii) HC measurement instruments shall be operated according to the instrument manufacturer's instructions.
  - (iii) If correction for dilution air background concentrations of HC is foreseen, background HC in the dilution air shall be measured and recorded.
  - (iv) Any integrating devices shall be zeroed.
  - (v) The contents of the  $\text{C}_3\text{H}_8$  reference cylinder shall be released at the rate selected.
  - (vi) Sampling shall begin, and any flow integrators started after confirming that HC concentration is to be stable.
  - (vii) The cylinder's contents shall be continued to be released until at least enough  $\text{C}_3\text{H}_8$  has been released to ensure accurate quantification of the reference  $\text{C}_3\text{H}_8$  and the measured  $\text{C}_3\text{H}_8$ .
  - (viii) Any integrators shall be stopped.

- (ix) The C<sub>3</sub>H<sub>8</sub> reference cylinder shall be shut off.

#### 8.1.8.5.6. Evaluation of the propane check

Post-test procedure shall be performed as follows:

- (a) If batch sampling has been used, batch samples shall be analyzed as soon as practical.
- (b) After analyzing HC, contamination and background shall be corrected for.
- (c) Total C<sub>3</sub>H<sub>8</sub> mass based on the CVS and HC data shall be calculated as described in Annexes A.7-A.8, using the molar mass of C<sub>3</sub>H<sub>8</sub>,  $M_{C_3H_8}$ , instead the effective molar mass of HC,  $M_{HC}$ .
- (d) If a reference mass (gravimetric technique) is used, the cylinder's propane mass shall be determined within  $\pm 0.5$  per cent and the C<sub>3</sub>H<sub>8</sub> reference mass shall be determined by subtracting the empty cylinder propane mass from the full cylinder propane mass. If a critical flow orifice (metering with a critical flow orifice) is used, the propane mass shall be determined as flow rate multiplied by the test time.
- (e) The reference C<sub>3</sub>H<sub>8</sub> mass shall be subtracted from the calculated mass. If this difference is within  $\pm 3.0$  per cent of the reference mass, the CVS passes this verification.

#### 8.1.8.5.7. PM secondary dilution system verification

When the propane check is to be repeated to verify the PM secondary dilution system, the following procedure from (a) to (d) shall be used for this verification:

- (a) The HC sampling system shall be configured to extract a sample near the location of the batch sampler's storage media (such as a PM filter). If the absolute pressure at this location is too low to extract an HC sample, HC may be sampled from the batch sampler pump's exhaust. Caution shall be used when sampling from pump exhaust because an otherwise acceptable pump leak downstream of a batch sampler flow meter will cause a false failure of the propane check.
- (b) The propane check shall be repeated as described in this paragraph, but HC shall be sampled from the batch sampler.
- (c) C<sub>3</sub>H<sub>8</sub> mass shall be calculated, taking into account any secondary dilution from the batch sampler.
- (d) The reference C<sub>3</sub>H<sub>8</sub> mass shall be subtracted from the calculated mass. If this difference is within  $\pm 5$  per cent of the reference mass, the batch sampler passes this verification. If not, corrective action shall be taken as described in paragraph (a) of this paragraph.

#### 8.1.8.5.8. Sample dryer verification

If a humidity sensor for continuous monitoring of dew point at the sample dryer outlet is used this check does not apply, as long as it is ensured that the dryer outlet humidity is below the minimum values used for quench, interference, and compensation checks.

- (a) If a sample dryer is used as allowed in paragraph 9.3.2.3.1.2. to remove water from the sample gas, the performance shall be verified upon installation, after major maintenance, for thermal chiller. For osmotic membrane dryers, the performance shall be verified upon installation, after major maintenance, and within 35 days of testing.
- (b) Water can inhibit an analyzer's ability to properly measure the exhaust component of interest and thus is sometimes removed before the sample gas reaches the analyzer. For example water can negatively interfere with a CLD's NO<sub>x</sub> response through collisional quenching and can positively interfere with an NDIR analyzer by causing a response similar to CO.
- (c) The sample dryer shall meet the specifications as determined in paragraph 9.3.2.3.1. for dew point,  $T_{\text{dew}}$ , and absolute pressure,  $p_{\text{total}}$ , downstream of the osmotic-membrane dryer or thermal chiller.
- (d) The following sample dryer verification procedure method shall be used to determine sample dryer performance, or good engineering judgment shall be used to develop a different protocol:
  - (i) PTFE or stainless steel tubing shall be used to make necessary connections.
  - (ii) N<sub>2</sub> or purified air shall be humidified by bubbling it through distilled water in a sealed vessel that humidifies the gas to the highest sample dew point that is estimated during emission sampling.
  - (iii) The humidified gas shall be introduced upstream of the sample dryer.
  - (iv) The humidified gas temperature downstream of the vessel shall be maintained at least 5 °C above its dew point.
  - (v) The humidified gas dew point,  $T_{\text{dew}}$ , and pressure,  $p_{\text{total}}$ , shall be measured as close as possible to the inlet of the sample dryer to verify that the dew point is the highest that was estimated during emission sampling.
  - (vi) The humidified gas dew point,  $T_{\text{dew}}$ , and pressure,  $p_{\text{total}}$ , shall be measured as close as possible to the outlet of the sample dryer.
  - (vii) The sample dryer meets the verification if the result of paragraph (d)(6) of this paragraph is less than the dew point corresponding to the sample dryer specifications as determined in paragraph 9.3.2.3.1. plus 2 °C or if the mol fraction from (d)(6) is less than the corresponding sample dryer specifications plus 0.002 mol/mol or 0.2 Vol per cent. Note for this verification, sample dew point is expressed in absolute temperature, Kelvin.

8.1.8.6. Periodic calibration of the partial flow PM and associated raw exhaust gas measurement systems

8.1.8.6.1. Specifications for differential flow measurement

For partial flow dilution systems to extract a proportional raw exhaust sample, the accuracy of the sample flow  $q_{mp}$  is of special concern, if not measured directly, but determined by differential flow measurement:



$$q_{mp} = q_{mdew} - q_{mdw} \quad (8-1)$$

Where:

- $q_{mp}$  = sample mass flow rate of exhaust gas into partial flow dilution system  
 $q_{mdw}$  = dilution air mass flow rate (on wet basis)  
 $q_{mdew}$  = diluted exhaust gas mass flow rate on wet basis

In this case, the maximum error of the difference shall be such that the accuracy of  $q_{mp}$  is within  $\pm 5$  per cent when the dilution ratio is less than 15. It can be calculated by taking root-mean-square of the errors of each instrument.

Acceptable accuracies of  $q_{mp}$  can be obtained by either of the following methods:

- (a) The absolute accuracies of  $q_{mdew}$  and  $q_{mdw}$  are  $\pm 0.2$  per cent which guarantees an accuracy of  $q_{mp}$  of  $\leq 5$  per cent at a dilution ratio of 15. However, greater errors will occur at higher dilution ratios.
- (b) Calibration of  $q_{mdw}$  relative to  $q_{mdew}$  is carried out such that the same accuracies for  $q_{mp}$  as in (a) are obtained. For details see paragraph 8.1.8.6.2.
- (c) The accuracy of  $q_{mp}$  is determined indirectly from the accuracy of the dilution ratio as determined by a tracer gas, e.g. CO<sub>2</sub>. Accuracies equivalent to method a) for  $q_{mp}$  are required.
- (d) The absolute accuracy of  $q_{mdew}$  and  $q_{mdw}$  is within  $\pm 2$  per cent of full scale, the maximum error of the difference between  $q_{mdew}$  and  $q_{mdw}$  is within 0.2 per cent and the linearity error is within  $\pm 0.2$  per cent of the highest  $q_{mdew}$  observed during the test.

#### 8.1.8.6.2. Calibration of differential flow measurement

The partial flow dilution system to extract a proportional raw exhaust sample shall be periodically calibrated with an accurate flow meter traceable to international and/or national standards. The flow meter or the flow measurement instrumentation shall be calibrated in one of the following procedures, such that the probe flow  $q_{mp}$  into the tunnel shall fulfil the accuracy requirements of paragraph 8.1.8.6.1.

- (a) The flow meter for  $q_{mdw}$  shall be connected in series to the flow meter for  $q_{mdew}$ , the difference between the two flow meters shall be calibrated for at least 5 set points with flow values equally spaced between the lowest  $q_{mdw}$  value used during the test and the value of  $q_{mdew}$  used during the test. The dilution tunnel may be bypassed.
- (b) A calibrated flow device shall be connected in series to the flowmeter for  $q_{mdew}$  and the accuracy shall be checked for the value used for the test. The calibrated flow device shall be connected in series to the flow meter for  $q_{mdw}$ , and the accuracy shall be checked for at least 5 settings corresponding to dilution ratio between 3 and 15, relative to  $q_{mdew}$  used during the test.
- (c) The transfer line TL (see figure 9.2) shall be disconnected from the exhaust and a calibrated flow measuring device with a suitable range to measure  $q_{mp}$  shall be connected to the transfer line.  $q_{mdew}$  shall be set to the value used during the test, and  $q_{mdw}$  shall be sequentially set to at least 5 values corresponding to dilution ratios between 3 and 15. Alternatively, a special calibration flow path

may be provided, in which the tunnel is bypassed, but the total and dilution air flow is passed through the corresponding meters as in the actual test.

- (d) A tracer gas, shall be fed into the exhaust transfer line TL. This tracer gas may be a component of the exhaust gas, like CO<sub>2</sub> or NO<sub>x</sub>. After dilution in the tunnel the tracer gas component shall be measured. This shall be carried out for 5 dilution ratios between 3 and 15. The accuracy of the sample flow shall be determined from the dilution ratio  $r_d$ :

$$q_{mp} = q_{mdew} / r_d \quad (8-2)$$

The accuracies of the gas analyzers shall be taken into account to guarantee the accuracy of  $q_{mp}$ .

#### 8.1.8.6.3. Special requirements for differential flow measurement

A carbon flow check using actual exhaust is strongly recommended for detecting measurement and control problems and verifying the proper operation of the partial flow system. The carbon flow check shall be run at least each time a new engine is installed, or something significant is changed in the test cell configuration.

The engine shall be operated at peak torque load and speed or any other steady state mode that produces 5 per cent or more of CO<sub>2</sub>. The partial flow sampling system shall be operated with a dilution factor of about 15 to 1.

If a carbon flow check is conducted, the procedure given in Annex A.4 shall be applied. The carbon flow rates shall be calculated according to equations of Annex A.4. All carbon flow rates shall agree to within 5 per cent.

##### 8.1.8.6.3.1. Pre-test check

A pre-test check shall be performed within 2 hours before the test run in the following way.

The accuracy of the flow meters shall be checked by the same method as used for calibration (see paragraph 8.1.8.6.2.) for at least two points, including flow values of  $q_{mdw}$  that correspond to dilution ratios between 5 and 15 for the  $q_{mdew}$  value used during the test.

If it can be demonstrated by records of the calibration procedure under paragraph 8.1.8.6.2. that the flow meter calibration is stable over a longer period of time, the pre-test check may be omitted.

##### 8.1.8.6.3.2. Determination of the transformation time

The system settings for the transformation time evaluation shall be the same as during measurement of the test run. The transformation time, defined in figure 3.1, shall be determined by the following method:

An independent reference flowmeter with a measurement range appropriate for the probe flow shall be put in series with and closely coupled to the probe. This flowmeter shall have a transformation time of less than 100 ms for the flow step size used in the response time measurement, with flow restriction sufficiently low as to not affect the dynamic performance of the partial flow dilution system according to good engineering judgment. A step change shall be introduced to the exhaust flow (or air flow if exhaust flow is calculated) input of the partial flow dilution system, from a low flow to at least 90 per cent of full scale. The trigger for the step change shall be the same one used to start the look-ahead control in actual testing. The exhaust flow step stimulus and the flowmeter response shall be recorded at a sample rate of at least 10 Hz.

From this data, the transformation time shall be determined for the partial flow dilution system, which is the time from the initiation of the step stimulus to the 50 per cent point of the flowmeter response. In a similar manner, the transformation times of the  $q_{mp}$  signal (i.e. sample flow of exhaust gas into partial flow dilution system) and of the  $q_{mew,i}$  signal (i.e. the exhaust gas mass flow rate on wet basis supplied by the exhaust flow meter) shall be determined. These signals are used in the regression checks performed after each test (see paragraph 8.2.1.2.).

The calculation shall be repeated for at least 5 rise and fall stimuli, and the results shall be averaged. The internal transformation time (<100 ms) of the reference flowmeter shall be subtracted from this value. In the case that the system in accordance with paragraph 8.2.1.2. requires the "look-ahead" method, this is the "look-ahead" value of the partial flow dilution system to be applied in accordance with paragraph 8.2.1.2.

#### 8.1.8.7. Vacuum-side leak verification

##### 8.1.8.7.1. Scope and frequency

Upon initial sampling system installation, after major maintenance such as pre-filter changes, and 8 hours prior to each duty-cycle sequence, it shall be verified that there are no significant vacuum-side leaks using one of the leak tests described in this section. This verification does not apply to any full-flow portion of a CVS dilution system.

##### 8.1.8.7.2. Measurement principles

A leak may be detected either by measuring a small amount of flow when there shall be zero flow, by detecting the dilution of a known concentration of span gas when it flows through the vacuum side of a sampling system or by measuring the pressure increase of an evacuated system.

##### 8.1.8.7.3. Low-flow leak test

A sampling system shall be tested for low-flow leaks as follows:

- (a) The probe end of the system shall be sealed by taking one of the following steps:
  - (i) The end of the sample probe shall be capped or plugged.
  - (ii) The transfer line shall be disconnected at the probe and the transfer line capped or plugged.
  - (iii) A leak-tight valve in-line between a probe and transfer line shall be closed.
- (b) All vacuum pumps shall be operated. After stabilizing, it shall be verified that the flow through the vacuum-side of the sampling system is less than 0.5 per cent of the system's normal in-use flow rate. Typical analyzer and bypass flows may be estimated as an approximation of the system's normal in-use flow rate.

#### 8.1.8.7.4. Dilution-of-span-gas leak test

Any gas analyzer may be used for this test. If a FID is used for this test, any HC contamination in the sampling system shall be corrected according to Annexes A.7 and A.8 on HC and NMHC determination. Misleading results shall be avoided by using only analyzers that have a repeatability of 0.5 per cent or better at the span gas concentration used for this test. The vacuum side leak check shall be performed as follows:

- (a) A gas analyzer shall be prepared as it would be for emission testing.
- (b) Span gas shall be supplied to the analyzer port and it shall be verified that the span gas concentration is measured within its expected measurement accuracy and repeatability.
- (c) Overflow span gas shall be routed to one of the following locations in the sampling system:
  - (i) The end of the sample probe.
  - (ii) The transfer line shall be disconnected at the probe connection, and the span gas overflowed at the open end of the transfer line.
  - (iii) A three-way valve installed in-line between a probe and its transfer line.
- (d) It shall be verified that the measured overflow span gas concentration is within  $\pm 0.5$  per cent of the span gas concentration. A measured value lower than expected indicates a leak, but a value higher than expected may indicate a problem with the span gas or the analyzer itself. A measured value higher than expected does not indicate a leak.

#### 8.1.8.7.5. Vacuum-decay leak test

To perform this test a vacuum shall be applied to the vacuum-side volume of the sampling system and the leak rate of the system shall be observed as a decay in the applied vacuum. To perform this test the vacuum-side volume of the sampling system shall be known to within  $\pm 10$  per cent of its true volume. For this test measurement instruments that meet the specifications of paragraphs 8.1. and 9.4. shall also be used.

A vacuum-decay leak test shall be performed as follows:

- (a) The probe end of the system shall be sealed as close to the probe opening as possible by taking one of the following steps:
  - (i) The end of the sample probe shall be capped or plugged.
  - (ii) The transfer line at the probe shall be disconnected and the transfer line capped or plugged.
  - (iii) A leak-tight valve in-line between a probe and transfer line shall be closed.
- (b) All vacuum pumps shall be operated. A vacuum shall be drawn that is representative of normal operating conditions. In the case of sample bags, it is recommended that the normal sample bag pump-down procedure be repeated twice to minimize any trapped volumes.
- (c) The sample pumps shall be turned off and the system sealed. The absolute pressure of the trapped gas and optionally the system absolute temperature shall be measured and recorded. Sufficient time shall be allowed for any transients to settle and long enough for a leak at 0.5 per cent to have caused a pressure change of at least 10 times the resolution of the pressure transducer. The pressure and optionally temperature shall be recorded once again.
- (d) The leak flow rate based on an assumed value of zero for pumped-down bag volumes and based on known values for the sample system volume, the initial and final pressures, optional temperatures, and elapsed time shall be calculated. It shall be verified that the vacuum-decay leak flow rate is less than 0.5 per cent of the system's normal in-use flow rate as follows:

$$q_{V\text{leak}} = \frac{V_{\text{vac}}}{R} \frac{\left( \frac{p_2}{T_2} - \frac{p_1}{T_1} \right)}{(t_2 - t_1)} \quad (8-3)$$

Where:

- $q_{V\text{leak}}$  = vacuum-decay leak rate [mol/s]  
 $V_{\text{vac}}$  = geometric volume of the vacuum-side of the sampling system [m<sup>3</sup>]  
 $R$  = molar gas constant [J/(mol·K)]  
 $p_2$  = vacuum-side absolute pressure at time  $t_2$  [Pa]  
 $T_2$  = vacuum-side absolute temperature at time  $t_2$  [K]  
 $p_1$  = vacuum-side absolute pressure at time  $t_1$  [Pa]  
 $T_1$  = vacuum-side absolute temperature at time  $t_1$  [K]  
 $t_2$  = time at completion of vacuum-decay leak verification test [s]  
 $t_1$  = time at start of vacuum-decay leak verification test [s]

8.1.9. CO and CO<sub>2</sub> measurements

8.1.9.1. H<sub>2</sub>O interference verification for CO<sub>2</sub> NDIR analyzers

8.1.9.1.1. Scope and frequency

If CO<sub>2</sub> is measured using an NDIR analyzer, the amount of H<sub>2</sub>O interference shall be verified after initial analyzer installation and after major maintenance.

8.1.9.1.2. Measurement principles

H<sub>2</sub>O can interfere with an NDIR analyzer's response to CO<sub>2</sub>. If the NDIR analyzer uses compensation algorithms that utilize measurements of other gases to meet this interference verification, simultaneously these other measurements shall be conducted to test the compensation algorithms during the analyzer interference verification.

8.1.9.1.3. System requirements

A CO<sub>2</sub> NDIR analyzer shall have an H<sub>2</sub>O interference that is within  $(0.0 \pm 0.4)$  mmol/mol (of the expected mean CO<sub>2</sub> concentration).

8.1.9.1.4. Procedure

The interference verification shall be performed as follows:

- (a) The CO<sub>2</sub> NDIR analyzer shall be started, operated, zeroed, and spanned as it would be before an emission test.
- (b) A humidified test gas shall be created by bubbling zero air that meets the specifications in paragraph 9.5.1 through distilled water in a sealed vessel. If the sample is not passed through a dryer, control the vessel temperature to generate an H<sub>2</sub>O level at least as high as the maximum expected during testing. If the sample is passed through a dryer during testing, control the vessel temperature to generate an H<sub>2</sub>O level at least as high as the level determined in paragraph 9.3.2.3.1.
- (c) The humidified test gas temperature shall be maintained at least 5 °C above its dew point downstream of the vessel.
- (d) The humidified test gas shall be introduced downstream of any sample dryer, if one is used during testing.
- (e) The water mole fraction,  $x_{\text{H}_2\text{O}}$ , of the humidified test gas shall be measured, as close as possible to the inlet of the analyzer. For example, dew point,  $T_{\text{dew}}$ , and absolute pressure  $p_{\text{total}}$ , shall be measured to calculate  $x_{\text{H}_2\text{O}}$ .
- (f) Good engineering judgment shall be used to prevent condensation in the transfer lines, fittings, or valves from the point where  $x_{\text{H}_2\text{O}}$  is measured to the analyzer.
- (g) Time shall be allowed for the analyzer response to stabilize. Stabilization time shall include time to purge the transfer line and to account for analyzer response.

- (h) While the analyzer measures the sample's concentration, 30 s of sampled data shall be recorded. The arithmetic mean of this data shall be calculated. The analyzer meets the interference verification if this value is within  $(0.0 \pm 0.4)$  mmol/mol

#### 8.1.9.2. H<sub>2</sub>O and CO<sub>2</sub> interference verification for CO NDIR analyzers

##### 8.1.9.2.1. Scope and frequency

If CO is measured using an NDIR analyzer, the amount of H<sub>2</sub>O and CO<sub>2</sub> interference shall be verified after initial analyzer installation and after major maintenance.

##### 8.1.9.2.2. Measurement principles

H<sub>2</sub>O and CO<sub>2</sub> can positively interfere with an NDIR analyzer by causing a response similar to CO. If the NDIR analyzer uses compensation algorithms that utilize measurements of other gases to meet this interference verification, simultaneously these other measurements shall be conducted to test the compensation algorithms during the analyzer interference verification.

##### 8.1.9.2.3. System requirements

A CO NDIR analyzer shall have combined H<sub>2</sub>O and CO<sub>2</sub> interference that is within  $\pm 2$  per cent of the expected mean concentration of CO.

##### 8.1.9.2.4. Procedure

The interference verification shall be performed as follows:

- (a) The CO NDIR analyzer shall be started, operated, zeroed, and spanned as it would be before an emission test.
- (b) A humidified CO<sub>2</sub> test gas shall be created by bubbling a CO<sub>2</sub> span gas through distilled water in a sealed vessel. If the sample is not passed through a dryer, the vessel temperature shall be controlled to generate an H<sub>2</sub>O level at least as high as the maximum expected during testing. If the sample is passed through a dryer during testing, the vessel temperature shall be controlled to generate an H<sub>2</sub>O level at least as high as the level determined in paragraph 8.1.8.5.8. A CO<sub>2</sub> span gas concentration shall be used at least as high as the maximum expected during testing.
- (c) The humidified CO<sub>2</sub> test gas shall be introduced downstream of any sample dryer, if one is used during testing.
- (d) The water mole fraction,  $x_{\text{H}_2\text{O}}$ , of the humidified test gas shall be measured, as close as possible to the inlet of the analyzer. For example, dew point,  $T_{\text{dew}}$ , and absolute pressure  $p_{\text{total}}$ , shall be measured to calculate  $x_{\text{H}_2\text{O}}$ .
- (e) Good engineering judgment shall be used to prevent condensation in the transfer lines, fittings, or valves from the point where  $x_{\text{H}_2\text{O}}$  is measured to the analyzer.
- (f) Time shall be allowed for the analyzer response to stabilize.

- (g) While the analyzer measures the sample's concentration, its output shall be recorded for 30 s. The arithmetic mean of this data shall be calculated.
- (h) The analyzer meets the interference verification if the result of paragraph (g) of this section meets the tolerance in paragraph 8.1.9.2.3.
- (i) Interference procedures for CO<sub>2</sub> and H<sub>2</sub>O may be also run separately. If the CO<sub>2</sub> and H<sub>2</sub>O levels used are higher than the maximum levels expected during testing, each observed interference value shall be scaled down by multiplying the observed interference by the ratio of the maximum expected concentration value to the actual value used during this procedure. Separate interference procedures concentrations of H<sub>2</sub>O (down to 0.025 mol/mol H<sub>2</sub>O content) that are lower than the maximum levels expected during testing may be run, but the observed H<sub>2</sub>O interference shall be scaled up by multiplying the observed interference by the ratio of the maximum expected H<sub>2</sub>O concentration value to the actual value used during this procedure. The sum of the two scaled interference values shall meet the tolerance in paragraph 8.1.9.2.3.

#### 8.1.10. Hydrocarbon measurements

##### 8.1.10.1. FID optimization and verification

###### 8.1.10.1.1. Scope and frequency

For all FID analyzers, the FID shall be calibrated upon initial installation. The calibration shall be repeated as needed using good engineering judgment. The following steps shall be performed for a FID that measures HC:

- (a) A FID's response to various hydrocarbons shall be optimized after initial analyzer installation and after major maintenance. FID response to propylene and toluene shall be between 0.9 and 1.1 relative to propane.
- (b) A FID's methane (CH<sub>4</sub>) response factor shall be determined after initial analyzer installation and after major maintenance as described in paragraph 8.1.10.1.4. of this section.
- (c) Methane (CH<sub>4</sub>) response shall be verified within 185 days before testing.

###### 8.1.10.1.2. Calibration

Good engineering judgment shall be used to develop a calibration procedure, such as one based on the FID-analyzer manufacturer's instructions and recommended frequency for calibrating the FID. For a FID that measures HC, it shall be calibrated using C<sub>3</sub>H<sub>8</sub> calibration gases that meet the specifications of paragraph 9.5.1. For a FID that measures CH<sub>4</sub>, it shall be calibrated using CH<sub>4</sub> calibration gases that meet the specifications of paragraph 9.5.1. Regardless of the calibration gas composition, it shall be calibrated on a carbon number basis of one (C<sub>1</sub>).



#### 8.1.10.1.3. HC FID response optimization

This procedure is only for FID analyzers that measure HC.

- (a) Instrument manufacturer requirements and good engineering judgment shall be used for initial instrument start-up and basic operating adjustment using FID fuel and zero air. Heated FIDs shall be within their required operating temperature ranges. FID response shall be optimized to meet the requirement of the hydrocarbon response factors and the oxygen interference check according to paragraphs 8.1.10.1.(a) and 8.1.10.2. at the most common analyzer range expected during emission testing. Higher analyzer range may be used according to the instrument manufacturer's recommendation and good engineering judgment in order to optimize FID accurately, if the common analyzer range is lower than the minimum range for the optimization specified by the instrument manufacturer.
- (b) Heated FIDs shall be within their required operating temperature ranges. FID response shall be optimized at the most common analyzer range expected during emission testing. With the fuel and airflow rates set at the manufacturer's recommendations, a span gas shall be introduced to the analyzer.
- (c) The following step from (1) to (4) or the procedure instructed by the instrument manufacturer shall be taken for optimization. The procedures outlined in SAE paper No. 770141 may be optionally used for optimization.
  - (i) The response at a given fuel flow shall be determined from the difference between the span gas response and the zero gas response.
  - (ii) The fuel flow shall be incrementally adjusted above and below the manufacturer's specification. The span and zero response at these fuel flows shall be recorded.
  - (iii) The difference between the span and zero response shall be plotted and the fuel flow adjusted to the rich side of the curve. This is the initial flow rate setting which may need further optimization depending on the results of the hydrocarbon response factors and the oxygen interference check according to paragraphs 8.1.10.1.(a) and 8.1.10.2.
  - (iv) If the oxygen interference or the hydrocarbon response factors do not meet the following specifications, the airflow shall be incrementally adjusted above and below the manufacturer's specifications, repeating paragraphs 8.1.10.1.(a) and 8.1.10.2. for each flow.
- (d) The optimum flow rates and/or pressures for FID fuel and burner air shall be determined, and they shall be sampled and recorded for future reference.

#### 8.1.10.1.4. HC FID CH<sub>4</sub> response factor determination

This procedure is only for FID analyzers that measure HC. Since FID analyzers generally have a different response to CH<sub>4</sub> versus C<sub>3</sub>H<sub>8</sub>, each THC FID analyzer's CH<sub>4</sub> response factor,  $RF_{CH_4[THC-FID]}$  shall be determined, after FID optimization. The most recent  $RF_{CH_4[THC-FID]}$  measured according to this paragraph shall be used in the calculations for HC determination described in Annex A.7. (molar based approach) or Annex A.8. (mass based approach) to compensate for CH<sub>4</sub> response.

$RF_{CH_4[THC-FID]}$  shall be determined as follows, noting that  $RF_{CH_4[THC-FID]}$  is not determined for FIDs that are calibrated and spanned using  $CH_4$  with a non-methane cutter:

- (a) A  $C_3H_8$  span gas concentration shall be selected to span the analyzer before emission testing. Only span gases that meet the specifications of paragraph 9.5.1. shall be selected and the  $C_3H_8$  concentration of the gas shall be recorded.
- (b) A  $CH_4$  span gas that meets the specifications of paragraph 9.5.1. shall be selected and the  $CH_4$  concentration of the gas shall be recorded.
- (c) The FID analyzer shall be operated according to the manufacturer's instructions.
- (d) It shall be confirmed that the FID analyzer has been calibrated using  $C_3H_8$ . Calibration shall be performed on a carbon number basis of one ( $C_1$ ).
- (e) The FID shall be zeroed with a zero gas used for emission testing.
- (f) The FID shall be spanned with the selected  $C_3H_8$  span gas.
- (g) The selected  $CH_4$  span gas shall be introduced at the sample port of the FID analyzer, the  $CH_4$  span gas that has been selected under paragraph (b) of this paragraph.
- (h) The analyzer response shall be stabilized. Stabilization time may include time to purge the analyzer and to account for its response.
- (i) While the analyzer measures the  $CH_4$  concentration, 30 s of sampled data shall be recorded and the arithmetic mean of these values shall be calculated.
- (j) The mean measured concentration shall be divided by the recorded span concentration of the  $CH_4$  calibration gas. The result is the FID analyzer's response factor for  $CH_4$ ,  $RF_{CH_4[THC-FID]}$ .

#### 8.1.10.1.5. HC FID methane ( $CH_4$ ) response verification

This procedure is only for FID analyzers that measure HC. If the value of  $RF_{CH_4[THC-FID]}$  from paragraph 8.1.10.1.4. is within  $\pm 5.0$  per cent of its most recent previously determined value, the HC FID passes the methane response verification.

- (a) It shall be first verified that the pressures and / or flow rates of FID fuel, burner air, and sample are each within  $\pm 0.5$  per cent of their most recent previously recorded values, as described in paragraph 8.1.10.1.3. of this section. If these flow rates have to be adjusted, a new  $RF_{CH_4[THC-FID]}$  shall be determined as described in paragraph 8.1.10.1.4. of this section. It should be verified that the value of  $RF_{CH_4[THC-FID]}$  determined is within the tolerance specified in this paragraph 8.1.10.1.5.
- (b) If  $RF_{CH_4[THC-FID]}$  is not within the tolerance specified in this paragraph 8.1.10.1.5., the FID response shall be re-optimized as described in paragraph 8.1.10.1.3. of this section.
- (c) A new  $RF_{CH_4[THC-FID]}$  shall be determined as described in paragraph 8.1.10.1.4. of this section. This new value of  $RF_{CH_4[THC-FID]}$  shall be used in the calculations for HC determination, as described in Annex A.7 (molar based approach) or Annex A.8 (mass based approach).

#### 8.1.10.2. Non-stoichiometric raw exhaust FID O<sub>2</sub> interference verification

##### 8.1.10.2.1. Scope and frequency

If FID analyzers are used for raw exhaust measurements, the amount of FID O<sub>2</sub> interference shall be verified upon initial installation and after major maintenance.

##### 8.1.10.2.2. Measurement principles

Changes in O<sub>2</sub> concentration in raw exhaust can affect FID response by changing FID flame temperature. FID fuel, burner air, and sample flow shall be optimized to meet this verification. FID performance shall be verified with the compensation algorithms for FID O<sub>2</sub> interference that is active during an emission test.

##### 8.1.10.2.3. System requirements

Any FID analyzer used during testing shall meet the FID O<sub>2</sub> interference verification according to the procedure in this section.

##### 8.1.10.2.4. Procedure

FID O<sub>2</sub> interference shall be determined as follows, noting that one or more gas dividers may be used to create reference gas concentrations that are required to perform this verification:

- (a) Three span reference gases shall be selected that meet the specifications in paragraph 9.5.1. and contain C<sub>3</sub>H<sub>8</sub> concentration used to span the analyzers before emissions testing. Only span gases that meet the specifications in paragraph 9.5.1. CH<sub>4</sub> span reference gases may be used for FIDs calibrated on CH<sub>4</sub> with a non-methane cutter. The three balance gas concentrations shall be selected such that the concentrations of O<sub>2</sub> and N<sub>2</sub> represent the minimum and maximum and intermediate O<sub>2</sub> concentrations expected during testing. The requirement for using the average O<sub>2</sub> concentration can be removed if the FID is calibrated with span gas balanced\_with the average expected oxygen concentration.
- (b) It shall be confirmed that the FID analyzer meets all the specifications of paragraph 8.1.10.1.
- (c) The FID analyzer shall be started and operated as it would be before an emission test. Regardless of the FID burner's air source during testing, zero air shall be used as the FID burner's air source for this verification.
- (d) The analyzer shall be set at zero.
- (e) The analyzer shall be spanned using a span gas that is used during emissions testing.
- (f) The zero response shall be checked by using the zero gas used during emission testing. It shall be proceeded to the next step if the mean zero response of 30 s of sampled data is within ±0.5 per cent of the span reference value used in paragraph (e) of this paragraph, otherwise the procedure shall be restarted at paragraph (d) of this paragraph.

- (g) The analyzer response shall be checked using the span gas that has the minimum concentration of O<sub>2</sub> expected during testing. The mean response of 30 s of stabilized sample data shall be recorded as  $x_{O_2\min HC}$ .
- (h) The zero response of the FID analyzer shall be checked using the zero gas used during emission testing. The next step shall be performed if the mean zero response of 30 s of stabilized sample data is within  $\pm 0.5$  per cent of the span reference value used in paragraph (e) of this paragraph, otherwise the procedure shall be restarted at paragraph (d) of this paragraph.
- (i) The analyzer response shall be checked using the span gas that has the average concentration of O<sub>2</sub> expected during testing. The mean response of 30 s of stabilized sample data shall be recorded as  $x_{O_2\text{avg} HC}$ .
- (j) The zero response of the FID analyzer shall be checked using the zero gas used during emission testing. The next step shall be performed if the mean zero response of 30 s of stabilized sample data is within  $\pm 0.5$  per cent of the span reference value used in paragraph (e) of this paragraph, otherwise the procedure shall be restarted at paragraph (d) of this paragraph.
- (k) The analyzer response shall be checked using the span gas that has the maximum concentration of O<sub>2</sub> expected during testing. The mean response of 30 s of stabilized sample data shall be recorded as  $x_{O_2\max HC}$ .
- (l) The zero response of the FID analyzer shall be checked using the zero gas used during emission testing. The next step shall be performed if the mean zero response of 30 s of stabilized sample data is within  $\pm 0.5$  per cent of the span reference value used in paragraph (e) of this paragraph, otherwise the procedure at paragraph (d) of this paragraph shall be restarted.
- (m) The percent difference between  $x_{O_2\max HC}$  and its reference gas concentration shall be calculated:
  - (i) The percent difference between  $x_{O_2\text{avg} HC}$  and its reference gas concentration shall be calculated.
  - (ii) The percent difference between  $x_{O_2\min HC}$  and its reference gas concentration shall be calculated.
  - (iii) The maximum percent difference of the three shall be determined. This is the O<sub>2</sub> interference.
- (n) If the O<sub>2</sub> interference is within  $\pm 3$  per cent, the FID passes the O<sub>2</sub> interference verification; otherwise one or more of the following need to be performed to address the deficiency:
  - (i) The verification shall be repeated to determine if a mistake was made during the procedure.
  - (ii) The zero and span gases for emission testing shall be selected that contain higher or lower O<sub>2</sub> concentrations and the verification shall be repeated.
  - (iii) The FID burner air, fuel, and sample flow rates shall be adjusted. Note that if these flow rates are adjusted on a THC FID to meet the O<sub>2</sub> interference verification, the  $RF_{CH_4}$  shall be reset for the next  $RF_{CH_4}$  verification. The O<sub>2</sub> interference verification shall be repeated after adjustment and  $RF_{CH_4}$  shall be determined.
  - (iv) The FID shall be repaired or replaced and the O<sub>2</sub> interference verification shall be repeated.

### 8.1.10.3. Non-methane cutter penetration fractions

#### 8.1.10.3.1. Scope and frequency

If a FID analyzer and a non-methane cutter (NMC) is used to measure methane ( $\text{CH}_4$ ), the non-methane cutter's conversion efficiencies of methane,  $E_{\text{CH}_4}$ , and ethane,  $E_{\text{C}_2\text{H}_6}$  shall be determined. As detailed in this paragraph, these conversion efficiencies may be determined as a combination of NMC conversion efficiencies and FID analyzer response factors, depending on the particular NMC and FID analyzer configuration.

This verification shall be performed after installing the non-methane cutter. This verification shall be repeated within 185 days of testing to verify that the catalytic activity of the cutter has not deteriorated.

#### 8.1.10.3.2. Measurement principles

A non-methane cutter is a heated catalyst that removes non-methane hydrocarbons from the exhaust stream before the FID analyzer measures the remaining hydrocarbon concentration. An ideal non-methane cutter would have a methane conversion efficiency  $E_{\text{CH}_4}$  [-] of 0 (that is, a methane penetration fraction,  $PF_{\text{CH}_4}$ , of 1.000), and the conversion efficiency for all other hydrocarbons would be 1.000, as represented by an ethane conversion efficiency  $E_{\text{C}_2\text{H}_6}$  [-] of 1 (that is, an ethane penetration fraction  $PF_{\text{C}_2\text{H}_6}$  [-] of 0). The emission calculations in Annex A.7. or Annex A.8. use this paragraph's measured values of conversion efficiencies  $E_{\text{CH}_4}$  and  $E_{\text{C}_2\text{H}_6}$  to account for less than ideal NMC performance.

#### 8.1.10.3.3. System requirements

NMC conversion efficiencies are not limited to a certain range. However, it is recommended that a non-methane cutter is optimized by adjusting its temperature to achieve a  $E_{\text{CH}_4} < 0.15$  and a  $E_{\text{C}_2\text{H}_6} > 0.98$  ( $PF_{\text{CH}_4} > 0.85$  and  $PF_{\text{C}_2\text{H}_6} < 0.02$ ) as determined by paragraph 8.1.10.3.4., as applicable. If adjusting NMC temperature does not result in achieving these specifications, it is recommended that the catalyst material is replaced. The most recently determined conversion values from this section shall be used to calculate HC emissions according to Annexes A.7-A.8 as applicable.

#### 8.1.10.3.4. Procedure

Any one of the procedures specified in paragraphs 8.1.10.3.4.1., 8.1.10.3.4.2. and 8.1.10.3.4.3. is recommended. An alternative method recommended by the instrument manufacturer may be used.

#### 8.1.10.3.4.1. Procedure for a FID calibrated with the NMC

If a FID is always calibrated to measure CH<sub>4</sub> with the NMC, then the FID shall be spanned with the NMC using a CH<sub>4</sub> span gas, the product of that FID's CH<sub>4</sub> response factor and CH<sub>4</sub> penetration fraction,  $RFPF_{CH_4[NMC-FID]}$ , shall be set equal to 1.0 (i.e. efficiency  $E_{CH_4}$  [-] is set to 0) for all emission calculations, and the combined ethane (C<sub>2</sub>H<sub>6</sub>) response factor and penetration fraction,  $RFPF_{C_2H_6[NMC-FID]}$  (and efficiency  $E_{C_2H_6}$  [-]) shall be determined as follows:

- (a) Both a CH<sub>4</sub> gas mixture and a C<sub>2</sub>H<sub>6</sub> analytical gas mixture shall be selected meeting the specifications of paragraph 9.5.1. Both a CH<sub>4</sub> concentration for spanning the FID during emission testing and a C<sub>2</sub>H<sub>6</sub> concentration that is typical of the peak NMHC concentration expected at the hydrocarbon standard or equal to THC analyzer's span value shall be selected.
- (b) The non-methane cutter shall be started, operated, and optimized according to the manufacturer's instructions, including any temperature optimization.
- (c) It shall be confirmed that the FID analyzer meets all the specifications of paragraph 8.1.10.1.
- (d) The FID analyzer shall be operated according to the manufacturer's instructions.
- (e) CH<sub>4</sub> span gas shall be used to span the FID with the cutter. The FID shall be spanned on a C<sub>1</sub> basis. For example, if the span gas has a CH<sub>4</sub> reference value of 100 μmol/mol, the correct FID response to that span gas is 100 μmol/mol because there is one carbon atom per CH<sub>4</sub> molecule.
- (f) The C<sub>2</sub>H<sub>6</sub> analytical gas mixture shall be introduced upstream of the non-methane cutter.
- (g) The analyzer response shall be stabilized. Stabilization time may include time to purge the non-methane cutter and to account for the analyzer's response.
- (h) While the analyzer measures a stable concentration, 30 s of sampled data shall be recorded and the arithmetic mean of these data points shall be calculated.
- (i) The mean shall be divided by the reference value of C<sub>2</sub>H<sub>6</sub>, converted to a C<sub>1</sub> basis. The result is the C<sub>2</sub>H<sub>6</sub> combined response factor and penetration fraction,  $RFPF_{C_2H_6[NMC-FID]}$ , equivalent to  $(1 - E_{C_2H_6} [-])$ . This combined response factor and penetration fraction and the product of the CH<sub>4</sub> response factor and CH<sub>4</sub> penetration fraction,  $RFPF_{CH_4[NMC-FID]}$ , which is set equal to 1.0, in emission calculations shall be used according to A.7. or A.8., as applicable.

#### 8.1.10.3.4.2. Procedure for a FID calibrated with propane bypassing the NMC

If a FID is used with an NMC that is calibrated with propane, C<sub>3</sub>H<sub>8</sub>, by bypassing the NMC, penetrations fractions  $PF_{C_2H_6[NMC-FID]}$  and  $PF_{CH_4[NMC-FID]}$  shall be determined as follows:

- (a) A CH<sub>4</sub> gas mixture and a C<sub>2</sub>H<sub>6</sub> analytical gas mixture shall be selected meeting the specifications of paragraph 9.5.1 with the CH<sub>4</sub> concentration typical of its peak concentration expected at the hydrocarbon standard and the C<sub>2</sub>H<sub>6</sub> concentration typical of the peak total hydrocarbon (THC) concentration expected at the hydrocarbon standard or the THC analyzer span value.

- (b) The non-methane cutter shall be started and operated according to the manufacturer's instructions, including any temperature optimization.
- (c) It shall be confirmed that the FID analyzer meets all the specifications of paragraph 8.1.10.1.
- (d) The FID analyzer shall be operated according to the manufacturer's instructions.
- (e) The FID shall be zeroed and spanned as it would be during emission testing. The FID shall be spanned by bypassing the cutter and by using C<sub>3</sub>H<sub>8</sub> span gas to span the FID. The FID shall be spanned on a C<sub>1</sub> basis.
- (f) The C<sub>2</sub>H<sub>6</sub> analytical gas mixture shall be introduced upstream of the non-methane cutter at the same point the zero gas was introduced.
- (g) Time shall be allowed for the analyzer response to stabilize. Stabilization time may include time to purge the non-methane cutter and to account for the analyzer's response.
- (h) While the analyzer measures a stable concentration, 30 s of sampled data shall be recorded and the arithmetic mean of these data points shall be calculated.
- (i) The flow path shall be rerouted to bypass the non-methane cutter, the C<sub>2</sub>H<sub>6</sub> analytical gas mixture shall be introduced to the bypass, and the steps in paragraphs (g) through (h) of this paragraph shall be repeated.
- (j) The mean C<sub>2</sub>H<sub>6</sub> concentration measured through the non-methane cutter shall be divided by the mean concentration measured after bypassing the non-methane cutter. The result is the C<sub>2</sub>H<sub>6</sub> penetration fraction,  $PF_{C_2H_6[NMC-FID]}$ , that is equivalent to  $(1 - E_{C_2H_6} [-])$ . This penetration fraction shall be used according to A.7. or A.8., as applicable.
- (k) The steps in paragraphs (f) through (j) of this paragraph shall be repeated, but with the CH<sub>4</sub> analytical gas mixture instead of C<sub>2</sub>H<sub>6</sub>. The result will be the CH<sub>4</sub> penetration fraction,  $PF_{CH_4[NMC-FID]}$  (equivalent to  $(1 - E_{CH_4} [-])$ ). This penetration fraction shall be used according to Annexes A.7-A.8, as applicable.

#### 8.1.10.3.4.3. Procedure for a FID calibrated with methane, bypassing the NMC

If a FID is used with an NMC that is calibrated with methane, CH<sub>4</sub>, by bypassing the NMC, determine its combined ethane (C<sub>2</sub>H<sub>6</sub>) response factor and penetration fraction,  $RFPF_{C_2H_6[NMC-FID]}$ , as well as its CH<sub>4</sub> penetration fraction,  $PF_{CH_4[NMC-FID]}$ , as follows:

- (a) CH<sub>4</sub> and C<sub>2</sub>H<sub>6</sub> analytical gas mixtures shall be selected that meet the specifications of paragraph 9.5.1., with the CH<sub>4</sub> concentration typical of its peak concentration expected at the hydrocarbon standard and the C<sub>2</sub>H<sub>6</sub> concentration typical of the peak total hydrocarbon (THC) concentration expected at the hydrocarbon standard or the THC analyzer span value.
- (b) The non-methane cutter shall be started and operated according to the manufacturer's instructions, including any temperature optimization.
- (c) It shall be confirmed that the FID analyzer meets all the specifications of paragraph 8.1.10.1.
- (d) The FID analyzer shall be started and operated according to the manufacturer's instructions.

- (e) The FID shall be zeroed and spanned as it would during emission testing. The FID shall be spanned with CH<sub>4</sub> span gas by bypassing the cutter. Note that the FID shall be spanned on a C<sub>1</sub> basis. For example, if the span gas has a methane reference value of 100 µmol/mol, the correct FID response to that span gas is 100 µmol/mol because there is one carbon atom per CH<sub>4</sub> molecule.
- (f) The C<sub>2</sub>H<sub>6</sub> analytical gas mixture shall be introduced upstream of the non-methane cutter at the same point the zero gas was introduced.
- (g) Time shall be allowed for the analyzer response to stabilize. Stabilization time may include time to purge the non-methane cutter and to account for the analyzer's response.
- (h) 30 s of sampled data shall be recorded while the analyzer measures a stable concentration. The arithmetic mean of these data points shall be calculated.
- (i) The flow path to bypass the non-methane cutter shall be rerouted, the C<sub>2</sub>H<sub>6</sub> analytical gas mixture shall be introduced to the bypass, and the steps in paragraphs (g) and (h) of this paragraph shall be repeated.
- (j) The mean C<sub>2</sub>H<sub>6</sub> concentration measured through the non-methane cutter shall be divided by the mean concentration measured after bypassing the non-methane cutter. The result is the C<sub>2</sub>H<sub>6</sub> combined response factor and penetration fraction,  $RFPF_{C_2H_6[NMC-FID]}$ . This combined response factor and penetration fraction shall be used according to Annexes A.7 and A.8., as applicable.
- (k) The steps in paragraphs (f) through (j) of this paragraph shall be repeated, but with the CH<sub>4</sub> analytical gas mixture instead of C<sub>2</sub>H<sub>6</sub>. The result will be the CH<sub>4</sub> penetration fraction,  $PF_{CH_4[NMC-FID]}$ . This penetration fraction shall be used according to Annexes A.7 and A.8., as applicable.

#### 8.1.11. NO<sub>x</sub> measurements

##### 8.1.11.1. CLD CO<sub>2</sub> and H<sub>2</sub>O quench verification

###### 8.1.11.1.1. Scope and frequency

If a CLD analyzer is used to measure NO<sub>x</sub>, the amount of H<sub>2</sub>O and CO<sub>2</sub> quench shall be verified after installing the CLD analyzer and after major maintenance.

###### 8.1.11.1.2. Measurement principles

H<sub>2</sub>O and CO<sub>2</sub> can negatively interfere with a CLD's NO<sub>x</sub> response by collisional quenching, which inhibits the chemiluminescent reaction that a CLD utilizes to detect NO<sub>x</sub>. This procedure and the calculations in paragraph 8.1.11.2.3. determine quench and scale the quench results to the maximum mole fraction of H<sub>2</sub>O and the maximum CO<sub>2</sub> concentration expected during emission testing. If the CLD analyzer uses quench compensation algorithms that utilize H<sub>2</sub>O and/or CO<sub>2</sub> measurement instruments, quench shall be evaluated with these instruments active and with the compensation algorithms applied.



#### 8.1.11.1.3. System requirements

For dilute measurement a CLD analyzer shall not exceed a combined H<sub>2</sub>O and CO<sub>2</sub> quench of  $\pm 2$  per cent. For raw measurement a CLD analyzer shall not exceed a combined H<sub>2</sub>O and CO<sub>2</sub> quench of  $\pm 2$  per cent. Combined quench is the sum of the CO<sub>2</sub> quench determined as described in paragraph 8.1.11.1.4. and the H<sub>2</sub>O quench as determined in paragraph 8.1.11.1.5. If these requirements are not met, corrective action shall be taken by repairing or replacing the analyzer. Before running emission tests, it shall be verified that the corrective action have successfully restored the analyzer to proper functioning.

#### 8.1.11.1.4. CO<sub>2</sub> quench verification procedure

The following method or the method prescribed by the instrument manufacturer may be used to determine CO<sub>2</sub> quench by using a gas divider that blends binary span gases with zero gas as the diluent and meets the specifications in paragraph 9.4.5.6., or good engineering judgment shall be used to develop a different protocol:

- (a) PTFE or stainless steel tubing shall be used to make necessary connections.
- (b) The gas divider shall be configured such that nearly equal amounts of the span and diluent gases are blended with each other.
- (c) If the CLD analyzer has an operating mode in which it detects NO-only, as opposed to total NO<sub>x</sub>, the CLD analyzer shall be operated in the NO-only operating mode.
- (d) A CO<sub>2</sub> span gas that meets the specifications of paragraph 9.5.1. and a concentration that is approximately twice the maximum CO<sub>2</sub> concentration expected during emission testing shall be used.
- (e) An NO span gas that meets the specifications of paragraph 9.5.1. and a concentration that is approximately twice the maximum NO concentration expected during emission testing shall be used. Higher concentration may be used according to the instrument manufacturer's recommendation and good engineering judgement in order to obtain accurate verification, if the expected NO concentration is lower than the minimum range for the verification specified by the instrument manufacturer.
- (f) The CLD analyzer shall be zeroed and spanned. The CLD analyzer shall be spanned with the NO span gas from paragraph (e) of this paragraph through the gas divider. The NO span gas shall be connected to the span port of the gas divider; a zero gas shall be connected to the diluent port of the gas divider; the same nominal blend ratio shall be used as selected in paragraph (b) of this paragraph; and the gas divider's output concentration of NO shall be used to span the CLD analyzer. Gas property corrections shall be applied as necessary to ensure accurate gas division.
- (g) The CO<sub>2</sub> span gas shall be connected to the span port of the gas divider.
- (h) The NO span gas shall be connected to the diluents port of the gas divider.
- (i) While flowing NO and CO<sub>2</sub> through the gas divider, the output of the gas divider shall be stabilized. The CO<sub>2</sub> concentration from the gas divider output shall be determined, applying gas property correction as necessary to ensure accurate gas division. This concentration,  $x_{\text{CO}_2\text{act}}$ , shall be recorded and it shall

be used in the quench verification calculations in paragraph 8.1.11.2.3. As an alternative to using a gas divider, another simple gas blending device may be used. In this case an analyzer shall be used to determine CO<sub>2</sub> concentration. If a NDIR is used together with a simple gas blending device, it shall meet the requirements of this section and it shall be spanned with the CO<sub>2</sub> span gas from paragraph (d) of this section. The linearity of the NDIR analyzer has to be checked before over the whole range up to twice of the expected maximum CO<sub>2</sub> concentration expected during testing.

- (j) The NO concentration shall be measured downstream of the gas divider with the CLD analyzer. Time shall be allowed for the analyzer response to stabilize. Stabilization time may include time to purge the transfer line and to account for analyzer response. While the analyzer measures the sample's concentration, the analyzer's output shall be recorded for 30 seconds. The arithmetic mean concentration shall be calculated from these data,  $x_{\text{NOmeas}}$ .  $x_{\text{NOmeas}}$  shall be recorded and it shall be used in the quench verification calculations in paragraph 8.1.11.2.3.
- (k) The actual NO concentration shall be calculated at the gas divider's outlet,  $x_{\text{NOact}}$ , based on the span gas concentrations and  $x_{\text{CO2act}}$  according to equation (8-5). The calculated value shall be used in the quench verification calculations in equation (8-4).
- (l) The values recorded according to this paragraphs 8.1.11.1.4. and 8.1.11.1.5. of this section shall be used to calculate quench as described in paragraph 8.1.11.2.3.

#### 8.1.11.1.5. H<sub>2</sub>O quench verification procedure

The following method or the method prescribed by the instrument manufacturer may be used to determine H<sub>2</sub>O quench, or good engineering judgment shall be used to develop a different protocol:

- (a) PTFE or stainless steel tubing shall be used to make necessary connections.
- (b) If the CLD analyzer has an operating mode in which it detects NO-only, as opposed to total NO<sub>x</sub>, the CLD analyzer shall be operated in the NO-only operating mode.
- (c) A NO span gas shall be used that meets the specifications of paragraph 9.5.1. and a concentration that is near the maximum concentration expected during emission testing. Higher concentration may be used according to the instrument manufacturer's recommendation and good engineering judgement in order to obtain accurate verification, if the expected NO concentration is lower than the minimum range for the verification specified by the instrument manufacturer.
- (d) The CLD analyzer shall be zeroed and spanned. The CLD analyzer shall be spanned with the NO span gas from paragraph (c) of this paragraph, the span gas concentration shall be recorded as  $x_{\text{NOdry}}$ , and it shall be used in the quench verification calculations in paragraph 8.1.11.2.3.
- (e) The NO span gas shall be humidified by bubbling it through distilled water in a sealed vessel. If the humidified NO span gas sample does not pass through a sample dryer for this verification test, the vessel temperature shall be controlled

- to generate an H<sub>2</sub>O level approximately equal to the maximum mole fraction of H<sub>2</sub>O expected during emission testing. If the humidified NO span gas sample does not pass through a sample dryer, the quench verification calculations in paragraph 8.1.11.2.3. scale the measured H<sub>2</sub>O quench to the highest mole fraction of H<sub>2</sub>O expected during emission testing. If the humidified NO span gas sample passes through a dryer for this verification test, the vessel temperature shall be controlled to generate an H<sub>2</sub>O level at least as high as the level determined in paragraph 9.3.2.3.1. For this case, the quench verification calculations in paragraph 8.1.11.2.3. do not scale the measured H<sub>2</sub>O quench.
- (f) The humidified NO test gas shall be introduced into the sample system. It may be introduced upstream or downstream of a sample dryer that is used during emission testing. Depending on the point of introduction, the respective calculation method of paragraph (e) shall be selected. Note that the sample dryer shall meet the sample dryer verification check in paragraph 8.1.8.5.8.
  - (g) The mole fraction of H<sub>2</sub>O in the humidified NO span gas shall be measured. In case a sample dryer is used, the mole fraction of H<sub>2</sub>O in the humidified NO span gas shall be measured downstream of the sample dryer,  $x_{\text{H}_2\text{O}_{\text{meas}}}$ . It is recommended to measure  $x_{\text{H}_2\text{O}_{\text{meas}}}$  as close as possible to the CLD analyzer inlet.  $x_{\text{H}_2\text{O}_{\text{meas}}}$  may be calculated from measurements of dew point,  $T_{\text{dew}}$ , and absolute pressure,  $p_{\text{total}}$ .
  - (h) Good engineering judgment shall be used to prevent condensation in the transfer lines, fittings, or valves from the point where  $x_{\text{H}_2\text{O}_{\text{meas}}}$  is measured to the analyzer. It is recommended that the system is designed so the wall temperatures in the transfer lines, fittings, and valves from the point where  $x_{\text{H}_2\text{O}_{\text{meas}}}$  is measured to the analyzer are at least 5 °C above the local sample gas dew point.
  - (i) The humidified NO span gas concentration shall be measured with the CLD analyzer. Time shall be allowed for the analyzer response to stabilize. Stabilization time may include time to purge the transfer line and to account for analyzer response. While the analyzer measures the sample's concentration, the analyzer's output shall be recorded for 30 seconds. The arithmetic mean shall be calculated of these data,  $x_{\text{NO}_{\text{wet}}}$ .  $x_{\text{NO}_{\text{wet}}}$  shall be recorded and used in the quench verification calculations in paragraph 8.1.11.2.3.

#### 8.1.11.2. CLD quench verification calculations

CLD quench-check calculations shall be performed as described in paragraph 8.1.11.1.

##### 8.1.11.2.1. Amount of water expected during testing

The maximum expected mole fraction of water during emission testing,  $x_{\text{H}_2\text{O}_{\text{exp}}}$  shall be estimated. This estimate shall be made where the humidified NO span gas was introduced in paragraph 8.1.11.1.5.(f). When estimating the maximum expected mole fraction of water, the maximum expected water content in combustion air, fuel combustion products, and dilution air (if applicable) shall be considered. If the humidified NO span gas is introduced into the sample system upstream of a sample

dryer during the verification test, it is not needed to estimate the maximum expected mole fraction of water and  $x_{\text{H}_2\text{Oexp}}$  shall be set equal to  $x_{\text{H}_2\text{Omeas}}$ .

#### 8.1.11.2.2. Amount of CO<sub>2</sub> expected during testing

The maximum expected CO<sub>2</sub> concentration during emission testing,  $x_{\text{CO}_2\text{exp}}$  shall be estimated. This estimate shall be made at the sample system location where the blended NO and CO<sub>2</sub> span gases are introduced according to paragraph 8.1.11.1.4.(j). When estimating the maximum expected CO<sub>2</sub> concentration, the maximum expected CO<sub>2</sub> content in fuel combustion products and dilution air shall be considered.

#### 8.1.11.2.3. Combined H<sub>2</sub>O and CO<sub>2</sub> quench calculations

Combined H<sub>2</sub>O and CO<sub>2</sub> quench shall be calculated as follows:

$$\text{quench} = \left[ \left( \frac{x_{\text{NOwet}}}{1 - x_{\text{H}_2\text{Omeas}}} - 1 \right) \cdot \frac{x_{\text{H}_2\text{Oexp}}}{x_{\text{H}_2\text{Omeas}}} + \left( \frac{x_{\text{NOmeas}}}{x_{\text{NOact}}} - 1 \right) \cdot \frac{x_{\text{CO}_2\text{exp}}}{x_{\text{CO}_2\text{act}}} \right] \cdot 100\% \quad (8-4)$$

Where:

$\text{quench}$  = amount of CLD quench

$x_{\text{NOdry}}$  = measured concentration of NO upstream of a bubbler, according to paragraph 8.1.11.1.5.(d)

$x_{\text{NOwet}}$  = measured concentration of NO downstream of a bubbler, according to paragraph 8.1.11.1.5.(i)

$x_{\text{H}_2\text{Oexp}}$  = maximum expected mole fraction of water during emission testing according to paragraph 8.1.11.2.1.

$x_{\text{H}_2\text{Omeas}}$  = measured mole fraction of water during the quench verification according to paragraph 8.1.11.1.4.(j)

$x_{\text{NOmeas}}$  = measured concentration of NO when NO span gas is blended with CO<sub>2</sub> span gas, according to paragraph 8.1.11.1.4.(j)

$x_{\text{NOact}}$  = actual concentration of NO when NO span gas is blended with CO<sub>2</sub> span gas, according to paragraph 8.1.11.1.4.(k) and calculated according to equation (8-5)

$x_{\text{CO}_2\text{exp}}$  = maximum expected concentration of CO<sub>2</sub> during emission testing, according to paragraph 8.1.11.1.3.

$x_{\text{CO}_2\text{act}}$  = actual concentration of CO<sub>2</sub> when NO span gas is blended with CO<sub>2</sub> span gas, according to paragraph 8.1.11.1.4.(i)

$$x_{\text{NOact}} = \left( 1 - \frac{x_{\text{CO}_2\text{act}}}{x_{\text{CO}_2\text{span}}} \right) \cdot x_{\text{NOspan}} \quad (8-5)$$

Where:

- $x_{\text{NOspan}}$  = the NO span gas concentration input to the gas divider, according to paragraph 8.1.11.1.4.(e)  
 $x_{\text{CO}_2\text{span}}$  = the CO<sub>2</sub> span gas concentration input to the gas divider, according to paragraph 8.1.11.1.4.(d)

### 8.1.11.3. NDUV analyzer HC and H<sub>2</sub>O interference verification

#### 8.1.11.3.1. Scope and frequency

If NO<sub>x</sub> is measured using an NDUV analyzer, the amount of H<sub>2</sub>O and hydrocarbon interference shall be verified after initial analyzer installation and after major maintenance.

#### 8.1.11.3.2. Measurement principles

Hydrocarbons and H<sub>2</sub>O can positively interfere with a NDUV analyzer by causing a response similar to NO<sub>x</sub>. If the NDUV analyzer uses compensation algorithms that utilize measurements of other gases to meet this interference verification, simultaneously such measurements shall be conducted to test the algorithms during the analyzer interference verification.

#### 8.1.11.3.3. System requirements

A NO<sub>x</sub> NDUV analyzer shall have combined H<sub>2</sub>O and HC interference within ±2 per cent of the mean concentration of NO<sub>x</sub>.

#### 8.1.11.3.4. Procedure

The interference verification shall be performed as follows:

- (a) The NO<sub>x</sub> NDUV analyzer shall be started, operated, zeroed, and spanned according to the instrument manufacturer's instructions.
- (b) It is recommended to extract engine exhaust to perform this verification. A CLD shall be used that meets the specifications of paragraph 9.4. to quantify NO<sub>x</sub> in the exhaust. The CLD response shall be used as the reference value. Also HC shall be measured in the exhaust with a FID analyzer that meets the specifications of paragraph 9.4. The FID response shall be used as the reference hydrocarbon value.
- (c) Upstream of any sample dryer, if one is used during testing, the engine exhaust shall be introduced into the NDUV analyzer.
- (d) Time shall be allowed for the analyzer response to stabilize. Stabilization time may include time to purge the transfer line and to account for analyzer response.
- (e) While all analyzers measure the sample's concentration, 30 s of sampled data shall be recorded, and the arithmetic means for the three analyzers calculated.
- (f) The CLD mean shall be subtracted from the NDUV mean.

- (g) This difference shall be multiplied by the ratio of the expected mean HC concentration to the HC concentration measured during the verification. The analyzer meets the interference verification of this paragraph if this result is within  $\pm 2$  per cent of the  $\text{NO}_x$  concentration expected at the standard:

$$\left( \bar{x}_{\text{NO}_x, \text{CLD, meas}} - \bar{x}_{\text{NO}_x, \text{NDUV, meas}} \right) \cdot \left( \frac{\bar{x}_{\text{HC, exp}}}{\bar{x}_{\text{HC, meas}}} \right) \leq 2\% \cdot \left( \bar{x}_{\text{NO}_x, \text{exp}} \right) \quad (8-6)$$

Where:

$\bar{x}$  [ $\mu\text{mol/mol}$ ] or [ppm] is the mean concentration of:

- (i)  $\text{NO}_x$  measured by CLD ( $\bar{x}_{\text{NO}_x, \text{CLD, meas}}$ ) and by NDUV ( $\bar{x}_{\text{NO}_x, \text{NDUV, meas}}$ )
- (ii) HC measured ( $\bar{x}_{\text{HC, meas}}$ )
- (iii) HC expected at the standard ( $\bar{x}_{\text{HC, exp}}$ )
- (iv)  $\text{NO}_x$  expected at the standard ( $\bar{x}_{\text{NO}_x, \text{exp}}$ )

$\left( \bar{x}_{\text{NO}_x, \text{CLD, meas}} - \bar{x}_{\text{NO}_x, \text{NDUV, meas}} \right)$  is the  $\text{NO}_x$  difference

$\left( \bar{x}_{\text{NO}_x, \text{CLD, meas}} - \bar{x}_{\text{NO}_x, \text{NDUV, meas}} \right) \cdot \left( \frac{\bar{x}_{\text{HC, exp}}}{\bar{x}_{\text{HC, meas}}} \right)$  is measured  $\text{NO}_x$  difference

corrected to expected HC

#### 8.1.11.3.5. Cooling bath (chiller) requirements

It shall be demonstrated that for the highest expected water vapour concentration  $H_m$ , the water removal technique maintains CLD humidity at  $\leq 5$  g water/kg dry air (or about 0.8 volume per cent  $\text{H}_2\text{O}$ ), which is 100 per cent relative humidity at 3.9 °C and 101.3 kPa. This humidity specification is also equivalent to about 25 per cent relative humidity at 25 °C and 101.3 kPa. This may be demonstrated by measuring the temperature at the outlet of a thermal dehumidifier, or by measuring humidity at a point just upstream of the CLD.

#### 8.1.11.4. Cooling bath (chiller) $\text{NO}_2$ penetration

##### 8.1.11.4.1. Scope and frequency

If a cooling bath (chiller) is used to dry a sample upstream of a  $\text{NO}_x$  measurement instrument, but no  $\text{NO}_2$ -to- $\text{NO}$  converter is used upstream of the cooling bath, this verification shall be performed for cooling bath  $\text{NO}_2$  penetration. This verification shall be performed after initial installation and after major maintenance.

##### 8.1.11.4.2. Measurement principles

A cooling bath (chiller) removes water, which can otherwise interfere with a  $\text{NO}_x$  measurement. However, liquid water remaining in an improperly designed cooling bath can remove  $\text{NO}_2$  from the sample. If a cooling bath is used without an  $\text{NO}_2$ -to-

NO converter upstream, it could therefore remove NO<sub>2</sub> from the sample prior NO<sub>x</sub> measurement.

#### 8.1.11.4.3. System requirements

The chiller shall allow for measuring at least 95 per cent of the total NO<sub>2</sub> at the maximum expected concentration of NO<sub>2</sub>.

#### 8.1.11.4.4. Procedure

The following procedure shall be used to verify chiller performance:

- (a) Instrument setup. The analyzer and chiller manufacturers' start-up and operating instructions shall be followed. The analyzer and chiller shall be adjusted as needed to optimize performance.
- (b) Equipment setup and data collection.
  - (i) The total NO<sub>x</sub> gas analyzer(s) shall be zeroed and spanned as it would be before emission testing.
  - (ii) NO<sub>2</sub> calibration gas (balance gas of dry air) that has an NO<sub>2</sub> concentration that is near the maximum expected during testing shall be selected. Higher concentration may be used according to the instrument manufacturer's recommendation and good engineering judgement in order to obtain accurate verification, if the expected NO<sub>2</sub> concentration is lower than the minimum range for the verification specified by the instrument manufacturer.
  - (iii) This calibration gas shall be overflowed at the gas sampling system's probe or overflow fitting. Time shall be allowed for stabilization of the total NO<sub>x</sub> response, accounting only for transport delays and instrument response.
  - (iv) The mean of 30 s of recorded total NO<sub>x</sub> data shall be calculated and this value recorded as  $x_{\text{NO}_x\text{ref}}$ .
  - (v) The flowing the NO<sub>2</sub> calibration gas shall be stopped.
  - (vi) Next the sampling system shall be saturated by overflowing a dew point generator's output, set at a dew point of 50 °C, to the gas sampling system's probe or overflow fitting. The dew point generator's output shall be sampled through the sampling system and chiller for at least 10 minutes until the chiller is expected to be removing a constant rate of water.
  - (vii) It shall be immediately switched back to overflowing the NO<sub>2</sub> calibration gas used to establish  $x_{\text{NO}_x\text{ref}}$ . It shall be allowed for stabilization of the total NO<sub>x</sub> response, accounting only for transport delays and instrument response. The mean of 30 s of recorded total NO<sub>x</sub> data shall be calculated and this value recorded as  $x_{\text{NO}_x\text{meas}}$ .
  - (viii)  $x_{\text{NO}_x\text{meas}}$  shall be corrected to  $x_{\text{NO}_x\text{dry}}$  based upon the residual water vapour that passed through the chiller at the chiller's outlet temperature and pressure.
- (c) Performance evaluation. If  $x_{\text{NO}_x\text{dry}}$  is less than 95 per cent of  $x_{\text{NO}_x\text{ref}}$ , the chiller shall be repaired or replaced .

#### 8.1.11.5. NO<sub>2</sub>-to-NO converter conversion verification

##### 8.1.11.5.1. Scope and frequency

If an analyzer is used that measures only NO to determine NO<sub>x</sub>, an NO<sub>2</sub>-to-NO converter shall be used upstream of the analyzer. This verification shall be performed after installing the converter, after major maintenance and within 35 days before an emission test. This verification shall be repeated at this frequency to verify that the catalytic activity of the NO<sub>2</sub>-to-NO converter has not deteriorated.

##### 8.1.11.5.2. Measurement principles

An NO<sub>2</sub>-to-NO converter allows an analyzer that measures only NO to determine total NO<sub>x</sub> by converting the NO<sub>2</sub> in exhaust to NO.

##### 8.1.11.5.3. System requirements

An NO<sub>2</sub>-to-NO converter shall allow for measuring at least 95 per cent of the total NO<sub>2</sub> at the maximum expected concentration of NO<sub>2</sub>.

##### 8.1.11.5.4 Procedure

The following procedure shall be used to verify the performance of a NO<sub>2</sub>-to-NO converter:

- (a) For the instrument setup the analyzer and NO<sub>2</sub>-to-NO converter manufacturers' start-up and operating instructions shall be followed. The analyzer and converter shall be adjusted as needed to optimize performance.
- (b) An ozonator's inlet shall be connected to a zero-air or oxygen source and its outlet shall be connected to one port of a 3-way tee fitting. An NO span gas shall be connected to another port and the NO<sub>2</sub>-to-NO converter inlet shall be connected to the last port.
- (c) The following steps shall be taken when performing this check:
  - (i) The ozonator air shall be set off and the ozonator power shall be turned off and the NO<sub>2</sub>-to-NO converter shall be set to the bypass mode (i.e., NO mode). Stabilization shall be allowed for, accounting only for transport delays and instrument response.
  - (ii) The NO and zero-gas flows shall be adjusted so the NO concentration at the analyzer is near the peak total NO<sub>x</sub> concentration expected during testing. The NO<sub>2</sub> content of the gas mixture shall be less than 5 per cent of the NO concentration. The concentration of NO shall be recorded by calculating the mean of 30 s of sampled data from the analyzer and this value shall be recorded as  $x_{\text{NOref}}$ . Higher concentration may be used according to the instrument manufacturer's recommendation and good engineering judgement in order to obtain accurate verification, if the expected NO concentration is lower than the minimum range for the verification specified by the instrument manufacturer.



- (iii) The ozonator O<sub>2</sub> supply shall be turned on and the O<sub>2</sub> flow rate adjusted so that the NO indicated by the analyzer is about 10 percent less than  $x_{\text{NOref}}$ . The concentration of NO shall be recorded by calculating the mean of 30 s of sampled data from the analyzer and this value recorded as  $x_{\text{NO+O2mix}}$ .
  - (iv) The ozonator shall be switched on and the ozone generation rate adjusted so that the NO measured by the analyzer is approximately 20 percent of  $x_{\text{NOref}}$ , while maintaining at least 10 per cent unreacted NO. The concentration of NO shall be recorded by calculating the mean of 30 s of sampled data from the analyzer and this value shall be recorded as  $x_{\text{NOmeas}}$ .
  - (v) The NO<sub>x</sub> analyzer shall be switched to NO<sub>x</sub> mode and total NO<sub>x</sub> measured. The concentration of NO<sub>x</sub> shall be recorded by calculating the mean of 30 s of sampled data from the analyzer and this value shall be recorded as  $x_{\text{NOxmeas}}$ .
  - (vi) The ozonator shall be switched off but gas flow through the system shall be maintained. The NO<sub>x</sub> analyzer will indicate the NO<sub>x</sub> in the NO + O<sub>2</sub> mixture. The concentration of NO<sub>x</sub> shall be recorded by calculating the mean of 30 s of sampled data from the analyzer and this value shall be recorded as  $x_{\text{NOx+O2mix}}$ .
  - (vii) O<sub>2</sub> supply shall be turned off. The NO<sub>x</sub> analyzer will indicate the NO<sub>x</sub> in the original NO-in-N<sub>2</sub> mixture. The concentration of NO<sub>x</sub> shall be recorded by calculating the mean of 30 s of sampled data from the analyzer and this value shall be recorded as  $x_{\text{NOxref}}$ . This value shall be no more than 5 per cent above the  $x_{\text{NOref}}$  value.
- (d) Performance evaluation. The efficiency of the NO<sub>x</sub> converter shall be calculated by substituting the concentrations obtained into the following equation:

$$\text{Efficiency}[\%] = \left( 1 + \frac{x_{\text{NOxmeas}} - x_{\text{NOx+O2mix}}}{x_{\text{NOx+O2mix}} - x_{\text{NOmeas}}} \right) \times 100 \quad (8-7)$$

- (e) If the result is less than 95 per cent, the NO<sub>2</sub>-to-NO converter shall be repaired or replaced.

#### 8.1.12. PM measurements

##### 8.1.12.1. PM balance verifications and weighing process verification

###### 8.1.12.1.1. Scope and frequency

This paragraph describes three verifications.

- (a) Independent verification of PM balance performance within 370 days prior to weighing any filter.
- (b) Zero and span of the balance within 12 h prior to weighing any filter.
- (c) Verification that the mass determination of reference filters before and after a filter weighing session be less than a specified tolerance.

#### 8.1.12.1.2. Independent verification

The balance manufacturer (or a representative approved by the balance manufacturer) shall verify the balance performance within 370 days of testing in accordance with internal audit procedures.

#### 8.1.12.1.3. Zeroing and spanning

Balance performance shall be verified by zeroing and spanning it with at least one calibration weight, and any weights that are used shall meet the specifications in paragraph 9.5.2. to perform this verification. A manual or automated procedure shall be used:

- (a) A manual procedure requires that the balance shall be used in which the balance shall be zeroed and spanned with at least one calibration weight. If normally mean values are obtained by repeating the weighing process to improve the accuracy and precision of PM measurements, the same process shall be used to verify balance performance.
- (b) An automated procedure is carried out with internal calibration weights that are used automatically to verify balance performance. These internal calibration weights shall meet the specifications in paragraph 9.5.2. to perform this verification.

#### 8.1.12.1.4. Reference sample weighing

All mass readings during a weighing session shall be verified by weighing reference PM sample media (e.g. filters) before and after a weighing session. A weighing session may be as short as desired, but no longer than 80 hours, and may include both pre- and post-test mass readings. Successive mass determinations of each reference PM sample media shall return the same value within  $\pm 10 \mu\text{g}$  or  $\pm 10$  per cent of the expected total PM mass, whichever is higher. Should successive PM sample filter weighing events fail this criterion, all individual test filter mass readings occurring between the successive reference filter mass determinations shall be invalidated. These filters may be re-weighed in another weighing session. Should a post-test filter be invalidated then the test interval is void. This verification shall be performed as follows:

- (a) At least two samples of unused PM sample media shall be kept in the PM-stabilization environment. These shall be used as references. Unused filters of the same material and size shall be selected for use as references.
- (b) References shall be stabilized in the PM stabilization environment. References shall be considered stabilized if they have been in the PM-stabilization environment for a minimum of 30 min, and the PM-stabilization environment has been within the specifications of paragraph 9.3.4.4. for at least the preceding 60 min.
- (c) The balance shall be exercised several times with a reference sample without recording the values.

- (d) The balance shall be zeroed and spanned. A test mass shall be placed on the balance (e.g. calibration weight) and then removed ensuring that the balance returns to an acceptable zero reading within the normal stabilization time.
- (e) Each of the reference media (e.g. filters) shall be weighed and their masses recorded. If normally mean values are obtained by repeating the weighing process to improve the accuracy and precision of reference media (e.g. filters) masses, the same process shall be used to measure mean values of sample media (e.g. filters) masses.
- (f) The balance environment dew point, ambient temperature, and atmospheric pressure shall be recorded.
- (g) The recorded ambient conditions shall be used to correct results for buoyancy as described in paragraph 8.1.12.2. The buoyancy-corrected mass of each of the references shall be recorded.
- (h) Each of the reference media's (e.g. filter's) buoyancy-corrected reference mass shall be subtracted from its previously measured and recorded buoyancy-corrected mass.
- (i) If any of the reference filters' observed mass changes by more than that allowed under this paragraph, all PM mass determinations made since the last successful reference media (e.g. filter) mass validation shall be invalidated. Reference PM filters may be discarded if only one of the filters mass has changed by more than the allowable amount and a special cause for that filter's mass change can be positively identified which would not have affected other in-process filters. Thus the validation can be considered a success. In this case, the contaminated reference media shall not be included when determining compliance with paragraph (j) of this paragraph, but the affected reference filter shall be discarded and replaced.
- (j) If any of the reference masses change by more than that allowed under this paragraph 8.1.12.1.4., all PM results that were determined between the two times that the reference masses were determined shall be invalidated. If reference PM sample media is discarded according to paragraph (i) of this paragraph, at least one reference mass difference that meets the criteria in this paragraph 8.1.12.1.4. shall be available. Otherwise, all PM results that were determined between the two times that the reference media (e.g. filters) masses were determined shall be invalidated.

#### 8.1.12.2. PM sample filter buoyancy correction

##### 8.1.12.2.1. General

PM sample filter shall be corrected for their buoyancy in air. The buoyancy correction depends on the sample media density, the density of air, and the density of the calibration weight used to calibrate the balance. The buoyancy correction does not account for the buoyancy of the PM itself, because the mass of PM typically accounts for only (0.01 to 0.10) per cent of the total weight. A correction to this small fraction of mass would be at the most 0.010 per cent. The buoyancy-corrected values are the tare masses of the PM samples. These buoyancy-corrected values of the pre-test filter weighing are subsequently subtracted from the buoyancy-corrected

values of the post-test weighing of the corresponding filter to determine the mass of PM emitted during the test.

#### 8.1.12.2.2. PM sample filter density

Different PM sample filter have different densities. The known density of the sample media shall be used, or one of the densities for some common sampling media shall be used, as follows:

- (a) For PTFE-coated borosilicate glass, a sample media density of 2300 kg/m<sup>3</sup> shall be used.
- (b) For PTFE membrane (film) media with an integral support ring of polymethylpentene that accounts for 95 per cent of the media mass, a sample media density of 920 kg/m<sup>3</sup> shall be used.
- (c) For PTFE membrane (film) media with an integral support ring of PTFE, a sample media density of 2144 kg/m<sup>3</sup> shall be used.

#### 8.1.12.2.3. Air density

Because a PM balance environment shall be tightly controlled to an ambient temperature of (22 ±1) °C and a dew point of (9.5 ±1) °C, air density is primarily function of atmospheric pressure. Therefore a buoyancy correction is specified that is only a function of atmospheric pressure.

#### 8.1.12.2.4. Calibration weight density

The stated density of the material of the metal calibration weight shall be used.

#### 8.1.12.2.5. Correction calculation

The PM sample filter shall be corrected for buoyancy using the following equations:

$$m_{\text{cor}} = m_{\text{uncor}} \left( \frac{1 - \frac{\rho_{\text{air}}}{\rho_{\text{weight}}}}{1 - \frac{\rho_{\text{air}}}{\rho_{\text{media}}}} \right) \quad (8-8)$$

Where:

- $m_{\text{cor}}$  = PM mass corrected for buoyancy  
 $m_{\text{uncor}}$  = PM mass uncorrected for buoyancy  
 $\rho_{\text{air}}$  = density of air in balance environment  
 $\rho_{\text{weight}}$  = density of calibration weight used to span balance  
 $\rho_{\text{media}}$  = density of PM sample filter

$$\rho_{\text{air}} = \frac{p_{\text{abs}} \cdot M_{\text{mix}}}{R \cdot T_{\text{amb}}} \quad (8-9)$$

Where:

- $p_{\text{abs}}$  = absolute pressure in balance environment  
 $M_{\text{mix}}$  = molar mass of air in balance environment  
 $R$  = molar gas constant.  
 $T_{\text{amb}}$  = absolute ambient temperature of balance environment

## 8.2. Instrument validation for test

### 8.2.1. Validation of proportional flow control for batch sampling and minimum dilution ratio for PM batch sampling

#### 8.2.1.1. Proportionality criteria for CVS

##### 8.2.1.1.1. Proportional flows

For any pair of flow meters, the recorded sample and total flow rates or their 1 Hz means shall be used with the statistical calculations in Annex A.2.9. The standard error of the estimate, *SEE*, of the sample flow rate versus the total flow rate shall be determined. For each test interval, it shall be demonstrated that *SEE* was less than or equal to 3.5 per cent of the mean sample flow rate.

##### 8.2.1.1.2. Constant flows

For any pair of flow meters, the recorded sample and total flow rates or their 1 Hz means shall be used to demonstrate that each flow rate was constant within  $\pm 2.5$  per cent of its respective mean or target flow rate. The following options may be used instead of recording the respective flow rate of each type of meter:

- (a) Critical-flow venturi option. For critical-flow venturis, the recorded venturi-inlet conditions or their 1 Hz means shall be used. It shall be demonstrated that the flow density at the venturi inlet was constant within  $\pm 2.5$  per cent of the mean or target density over each test interval. For a CVS critical-flow venturi, this may be demonstrated by showing that the absolute temperature at the venturi inlet was constant within  $\pm 4$  per cent of the mean or target absolute temperature over each test interval.
- (b) Positive-displacement pump option. The recorded pump-inlet conditions or their 1 Hz means shall be used. It shall be demonstrated that the flow density at the pump inlet was constant within  $\pm 2.5$  per cent of the mean or target density over each test interval. For a CVS pump, this may be demonstrated by showing that the absolute temperature at the pump inlet was constant within  $\pm 2$  per cent of the mean or target absolute temperature over each test interval.

##### 8.2.1.1.3. Demonstration of proportional sampling

For any proportional batch sample such as a bag or PM filter, it shall be demonstrated that proportional sampling was maintained using one of the following,

noting that up to 5 per cent of the total number of data points may be omitted as outliers.

Using good engineering judgment, it shall be demonstrated with an engineering analysis that the proportional-flow control system inherently ensures proportional sampling under all circumstances expected during testing. For example, CFVs may be used for both sample flow and total flow if it is demonstrated that they always have the same inlet pressures and temperatures and that they always operate under critical-flow conditions.

Measured or calculated flows and/or tracer gas concentrations (e.g. CO<sub>2</sub>) shall be used to determine the minimum dilution ratio for PM batch sampling over the test interval.

#### 8.2.1.2. Partial flow dilution system validation

For the control of a partial flow dilution system to extract a proportional raw exhaust sample, a fast system response is required; this is identified by the promptness of the partial flow dilution system. The transformation time for the system shall be determined by the procedure in paragraph 8.1.8.6. and the related figure 3.1. The actual control of the partial flow dilution system shall be based on the current measured conditions. If the combined transformation time of the exhaust flow measurement and the partial flow system is  $\leq 0.3$  s, online control shall be used. If the transformation time exceeds 0.3 s, look-ahead control based on a pre-recorded test run shall be used. In this case, the combined rise time shall be  $\leq 1$  s and the combined delay time  $\leq 10$  s. The total system response shall be designed as to ensure a representative sample of the particulates,  $q_{mp,i}$  (sample flow of exhaust gas into partial flow dilution system), proportional to the exhaust mass flow. To determine the proportionality, a regression analysis of  $q_{mp,i}$  versus  $q_{mew,i}$  (exhaust gas mass flow rate on wet basis) shall be conducted on a minimum 5 Hz data acquisition rate, and the following criteria shall be met:

- (a) The correlation coefficient  $r^2$  of the linear regression between  $q_{mp,i}$  and  $q_{mew,i}$  shall not be less than 0.95.
- (b) The standard error of estimate of  $q_{mp,i}$  on  $q_{mew,i}$  shall not exceed 5 per cent of  $q_{mp}$  maximum.
- (c)  $q_{mp}$  intercept of the regression line shall not exceed  $\pm 2$  per cent of  $q_{mp}$  maximum.

Look-ahead control is required if the combined transformation times of the particulate system,  $t_{50,P}$  and of the exhaust mass flow signal,  $t_{50,F}$  are  $> 0.3$  s. In this case, a pre-test shall be run and the exhaust mass flow signal of the pre-test be used for controlling the sample flow into the particulate system. A correct control of the partial dilution system is obtained, if the time trace of  $q_{mew,pre}$  of the pre-test, which controls  $q_{mp}$ , is shifted by a "look-ahead" time of  $t_{50,P} + t_{50,F}$ .

For establishing the correlation between  $q_{mp,i}$  and  $q_{mew,i}$  the data taken during the actual test shall be used, with  $q_{mew,i}$  time aligned by  $t_{50,F}$  relative to  $q_{mp,i}$  (no

contribution from  $t_{50,P}$  to the time alignment). The time shift between  $q_{mew}$  and  $q_{mp}$  is the difference between their transformation times that were determined in paragraph 8.1.8.6.3.2.

8.2.2. Gas analyzer range validation, drift validation and drift correction

8.2.2.1. Range validation

If an analyzer operated above 100 per cent of its range at any time during the test, the following steps shall be performed:

8.2.2.1.1. Batch sampling

For batch sampling, the sample shall be re-analyzed using the lowest analyzer range that results in a maximum instrument response below 100 per cent. The result shall be reported from the lowest range from which the analyzer operates below 100 per cent of its range for the entire test.

8.2.2.1.2. Continuous sampling

For continuous sampling, the entire test shall be repeated using the next higher analyzer range. If the analyzer again operates above 100 per cent of its range, the test shall be repeated using the next higher range. The test shall be continued to be repeated until the analyzer always operates at less than 100 per cent of its range for the entire test.

8.2.2.2. Drift validation and drift correction

If the drift is within  $\pm 1$  per cent, the data can be either accepted without any correction or accepted after correction. If the drift is greater than  $\pm 1$  per cent, two sets of brake specific emission results shall be calculated for each pollutant, or the test shall be voided. One set shall be calculated using data before drift correction and another set of data calculated after correcting all the data for drift according to Appendix 2 of Annexes A.7. or A.8. The comparison shall be made as a percentage of the uncorrected results. The difference between the uncorrected and the corrected brake-specific emission values shall be within  $\pm 4$  per cent of the uncorrected brake-specific emission values. If not, the entire test is void.

8.2.3. PM sampling media (e.g. filters) preconditioning and tare weighing

Before an emission test, the following steps shall be taken to prepare PM sample filter media and equipment for PM measurements:

8.2.3.1. Periodic verifications

It shall be made sure that the balance and PM-stabilization environments meet the periodic verifications in paragraph 8.1.12. The reference filter shall be weighed just

before weighing test filters to establish an appropriate reference point (see section details of the procedure in paragraph 8.1.12.1.). The verification of the stability of the reference filters shall occur after the post-test stabilisation period, immediately before the post-test weighing.

8.2.3.2. Visual Inspection

The unused sample filter media shall be visually inspected for defects, defective filters shall be discarded.

8.2.3.3. Grounding

Electrically grounded tweezers or a grounding strap shall be used to handle PM filters as described in paragraph 9.3.4.

8.2.3.4. Unused sample media

Unused sample media shall be placed in one or more containers that are open to the PM-stabilization environment. If filters are used, they may be placed in the bottom half of a filter cassette.

8.2.3.5. Stabilization

Sample media shall be stabilized in the PM-stabilization environment. An unused sample medium can be considered stabilized as long as it has been in the PM-stabilization environment for a minimum of 30 min, during which the PM-stabilization environment has been within the specifications of paragraph 9.3.4.

8.2.3.6. Weighing

The sample media shall be weighed automatically or manually, as follows:

- (a) For automatic weighing, the automation system manufacturer's instructions shall be followed to prepare samples for weighing.
- (b) For manual weighing, good engineering judgment shall be used.
- (c) Optionally, substitution weighing is permitted (see paragraph 8.2.3.10).
- (d) Once a filter is weighed it shall be returned to the Petri dish and covered.

8.2.3.7. Buoyancy correction

The measured weight shall be corrected for buoyancy as described in paragraph 8.1.12.2.

8.2.3.8. Repetition

The filter mass measurements may be repeated to determine the average mass of the filter using good engineering judgement and to exclude outliers from the calculation of the average.



8.2.3.9. Tare-weighing

Unused filters that have been tare-weighed shall be loaded into clean filter cassettes and the loaded cassettes shall be placed in a covered or sealed container before they are taken to the test cell for sampling.

8.2.3.10. Substitution weighing

Substitution weighing is an option and, if used, involves measurement of a reference weight before and after each weighing of a PM sampling medium (e.g. filter). While substitution weighing requires more measurements, it corrects for a balance's zero-drift and it relies on balance linearity only over a small range. This is most appropriate when quantifying total PM masses that are less than 0.1 per cent of the sample medium's mass. However, it may not be appropriate when total PM masses exceed 1 per cent of the sample medium's mass. If substitution weighing is used, it shall be used for both pre-test and post-test weighing. The same substitution weight shall be used for both pre-test and post-test weighing. The mass of the substitution weight shall be corrected for buoyancy if the density of the substitution weight is less than  $2.0 \text{ g/cm}^3$ . The following steps are an example of substitution weighing:

- (a) Electrically grounded tweezers or a grounding strap shall be used, as described in paragraph 9.3.4.6.
- (b) A static neutralizer shall be used as described in paragraph 9.3.4.6 to minimize static electric charge on any object before it is placed on the balance pan.
- (c) A substitution weight shall be selected that meets the specifications for calibration weights in paragraph 9.5.2. The substitution weight shall also have the same density as the weight that is used to span the microbalance, and shall be similar in mass to an unused sample medium (e.g. filter). If filters are used, the weight's mass should be about (80 to 100) mg for typical 47 mm diameter filters.
- (d) The stable balance reading shall be recorded and then the calibration weight shall be removed.
- (e) An unused sampling medium (e.g. a new filter) shall be weighed, the stable balance reading recorded and the balance environment's dew point, ambient temperature, and atmospheric pressure recorded.
- (f) The calibration weight shall be reweighed and the stable balance reading recorded.
- (g) The arithmetic mean of the two calibration-weight readings that were recorded immediately before and after weighing the unused sample shall be calculated. That mean value shall be subtracted from the unused sample reading, then the true mass of the calibration weight as stated on the calibration-weight certificate shall be added. This result shall be recorded. This is the unused sample's tare weight without correcting for buoyancy.
- (h) These substitution-weighing steps shall be repeated for the remainder of the unused sample media.
- (i) The instructions given in paragraphs 8.2.3.7. through 8.2.3.9. of this section shall be followed once weighing is completed.

#### 8.2.4. PM sample post-conditioning and total weighing

##### 8.2.4.1. Periodic verification

It shall be assured that the weighing and PM-stabilization environments have met the periodic verifications in paragraph 8.1.12.1. After testing is complete, the filters shall be returned to the weighing and PM-stabilisation environment. The weighing and PM-stabilisation environment shall meet the ambient conditions requirements in paragraph 9.3.4.4., otherwise the test filters shall be left covered until proper conditions have been met.

##### 8.2.4.2. Removal from sealed containers

In the PM-stabilization environment, the PM samples shall be removed from the sealed containers. Filters may be removed from their cassettes before or after stabilization. When a filter is removed from a cassette, the top half of the cassette shall be separated from the bottom half using a cassette separator designed for this purpose.

##### 8.2.4.3. Electrical grounding

To handle PM samples, electrically grounded tweezers or a grounding strap shall be used, as described in paragraph 9.3.4.5.

##### 8.2.4.4. Visual inspection

The collected PM samples and the associated filter media shall be inspected visually. If the conditions of either the filter or the collected PM sample appear to have been compromised, or if the particulate matter contacts any surface other than the filter, the sample may not be used to determine particulate emissions. In the case of contact with another surface; the affected surface shall be cleaned before proceeding.

##### 8.2.4.5. Stabilisation of PM samples

To stabilise PM samples, they shall be placed in one or more containers that are open to the PM-stabilization environment, which is described in paragraph 9.3.4.4. A PM sample is stabilized as long as it has been in the PM-stabilization environment for one of the following durations, during which the stabilization environment has been within the specifications of paragraph 9.3.4.4.:

- (a) If it is expected that a filter's total surface concentration of PM will be greater than  $0.353 \mu\text{g}/\text{mm}^2$ , assuming a  $400 \mu\text{g}$  loading on a 38 mm diameter filter stain area, the filter shall be exposed to the stabilization environment for at least 60 minutes before weighing.
- (b) If it is expected that a filter's total surface concentration of PM will be less than  $0.353 \mu\text{g}/\text{mm}^2$ , the filter shall be exposed to the stabilization environment for at least 30 minutes before weighing.

- (c) If a filter's total surface concentration of PM to be expected during the test is unknown, the filter shall be exposed to the stabilization environment for at least 60 minutes before weighing.

8.2.4.6. Determination of post-test filter mass

The procedures in paragraph 8.2.3. shall be repeated (paragraphs 8.2.3.6. through 8.2.3.9.) to determine the post-test filter mass.

8.2.4.7. Total mass

Each buoyancy-corrected filter tare mass shall be subtracted from its respective buoyancy-corrected post-test filter mass. The result is the total mass,  $m_{total}$ , which shall be used in emission calculations in Annexes A.7. and A.8.

9. MEASUREMENT EQUIPMENT

9.1. Engine dynamometer specification

9.1.1. Shaft work

An engine dynamometer shall be used that has adequate characteristics to perform the applicable duty cycle including the ability to meet appropriate cycle validation criteria. The following dynamometers may be used:

- (a) Eddy-current or water-brake dynamometers;
- (b) Alternating-current or direct-current motoring dynamometers;
- (c) One or more dynamometers.

9.1.2. Transient cycle

Load cell or in-line torque meter may be used for torque measurements.

When using a load cell, the torque signal shall be transferred to the engine axis and the inertia of the dynamometer shall be considered. The actual engine torque is the torque read on the load cell plus the moment of inertia of the brake multiplied by the angular acceleration. The control system has to perform such a calculation in real time.

9.1.3. Engine accessories

The work of engine accessories required to fuel, lubricate, or heat the engine, circulate liquid coolant to the engine, or to operate after-treatment devices shall be accounted for and they shall be installed in accordance with paragraph 6.3.

9.2. Dilution procedure (if applicable)

9.2.1. Diluent conditions and background concentrations

Gaseous constituents may be measured raw or dilute whereas PM measurement generally requires dilution. Dilution may be accomplished by a full flow or partial flow dilution system. When dilution is applied then the exhaust may be diluted with ambient air, synthetic air, or nitrogen. For gaseous emissions measurement the diluent shall be at least 15 °C. For PM sampling the temperature of the diluent is specified in paragraphs 9.2.2. for CVS and 9.2.3. for PFD with varying dilution ratio. The flow capacity of the dilution system shall be large enough to completely eliminate water condensation in the dilution and sampling systems. De-humidifying the dilution air before entering the dilution system is permitted, if the air humidity is high. The dilution tunnel walls may be heated or insulated as well as the bulk stream tubing downstream of the tunnel to prevent aqueous condensation.

Before a diluent is mixed with exhaust, it may be preconditioned by increasing or decreasing its temperature or humidity. Constituents may be removed from the diluent to reduce their background concentrations. The following provisions apply to removing constituents or accounting for background concentrations:

- (a) Constituent concentrations in the diluent may be measured and compensated for background effects on test results. See Annexes A.7-A.8 for calculations that compensate for background concentrations.
- (b) To account for background PM the following options are available:
  - (i) For removing background PM, the diluent shall be filtered with high-efficiency particulate air (HEPA) filters that have an initial minimum collection efficiency specification of 99.97 per cent (see 3.1. for procedures related to HEPA-filtration efficiencies).
  - (ii) For correcting for background PM without HEPA filtration, the background PM shall not contribute more than 50 per cent of the net PM collected on the sample filter.
  - (iii) Background correction of net PM with HEPA filtration is permitted without restriction.

9.2.2. Full flow system

Full-flow dilution; constant-volume sampling (CVS). The full flow of raw exhaust is diluted in a dilution tunnel. Constant flow may be maintained by maintaining the temperature and pressure at the flow meter within the limits. For non constant flow the flow shall be measured directly to allow for proportional sampling. The system shall be designed as follows (see figure 9.1):

- (a) A tunnel with inside surfaces of stainless steel shall be used. The entire dilution tunnel shall be electrically grounded.
- (b) The exhaust system backpressure shall not be artificially lowered by the dilution air inlet system. The static pressure at the location where raw exhaust is introduced into the tunnel shall be maintained within  $\pm 1.2$  kPa of atmospheric pressure.

- (c) To support mixing the raw exhaust shall be introduced into the tunnel by directing it downstream along the centreline of the tunnel. A fraction of dilution air maybe introduced radially from the tunnel's inner surface to minimize exhaust interaction with the tunnel walls.
- (d) Diluent. For PM sampling the temperature of the diluents (ambient air, synthetic air, or nitrogen as quoted in paragraph 9.2.1.) shall be maintained within one of the following ranges (option):
  - (i) between 293 and 303 K (20 and 30 °C) or
  - (ii) between 293 and 325 K (20 to 52°C)The range shall be selected by the Contracting Party.
- (e) The Reynolds number,  $Re$ , shall be at least 4000 for the diluted exhaust stream, where  $Re$  is based on the inside diameter of the dilution tunnel.  $Re$  is defined in Annexes A.7-A.8. Verification of adequate mixing shall be performed while traversing a sampling probe across the tunnel's diameter, vertically and horizontally. If the analyzer response indicates any deviation exceeding  $\pm 2$  per cent of the mean measured concentration, the CVS shall be operated at a higher flow rate or a mixing plate or orifice shall be installed to improve mixing.
- (f) Flow measurement preconditioning. The diluted exhaust may be conditioned before measuring its flow rate, as long as this conditioning takes place downstream of heated HC or PM sample probes, as follows:
  - (i) Flow straighteners, pulsation dampeners, or both of these maybe used.
  - (ii) A filter maybe used.
  - (iii) A heat exchanger maybe used to control the temperature upstream of any flow meter but steps shall be taken to prevent aqueous condensation.
- (g) Aqueous condensation. To ensure that a flow is measured that corresponds to a measured concentration, either aqueous condensation shall be prevented between the sample probe location and the flow meter inlet in the dilution tunnel or aqueous condensation shall be allowed to occur and humidity at the flow meter inlet measured. The dilution tunnel walls or bulk stream tubing downstream of the tunnel may be heated or insulated to prevent aqueous condensation. Aqueous condensation shall be prevented throughout the dilution tunnel. Certain exhaust components can be diluted or eliminated by the presence of moisture.

For PM sampling, the already proportional flow coming from CVS goes through secondary dilution (one or more) to achieve the requested overall dilution ratio as shown in figure 9.2 and mentioned in paragraph 9.2.3.2.
- (h) The minimum overall dilution ratio shall be within the range of 5:1 to 7:1 and at least 2:1 for the primary dilution stage based on the maximum engine exhaust flow rate during the test cycle or test interval.
- (i) The overall residence time in the system shall be between 0.5 and 5 seconds, as measured from the point of diluent introduction to the filter holder(s).
- (j) The residence time in the secondary dilution system, if present, shall be at least 0.5 seconds, as measured from the point of secondary diluent introduction to the filter holder(s).

To determine the mass of the particulates, a particulate sampling system, a particulate sampling filter, a gravimetric balance, and a temperature and humidity controlled weighing chamber, are required.

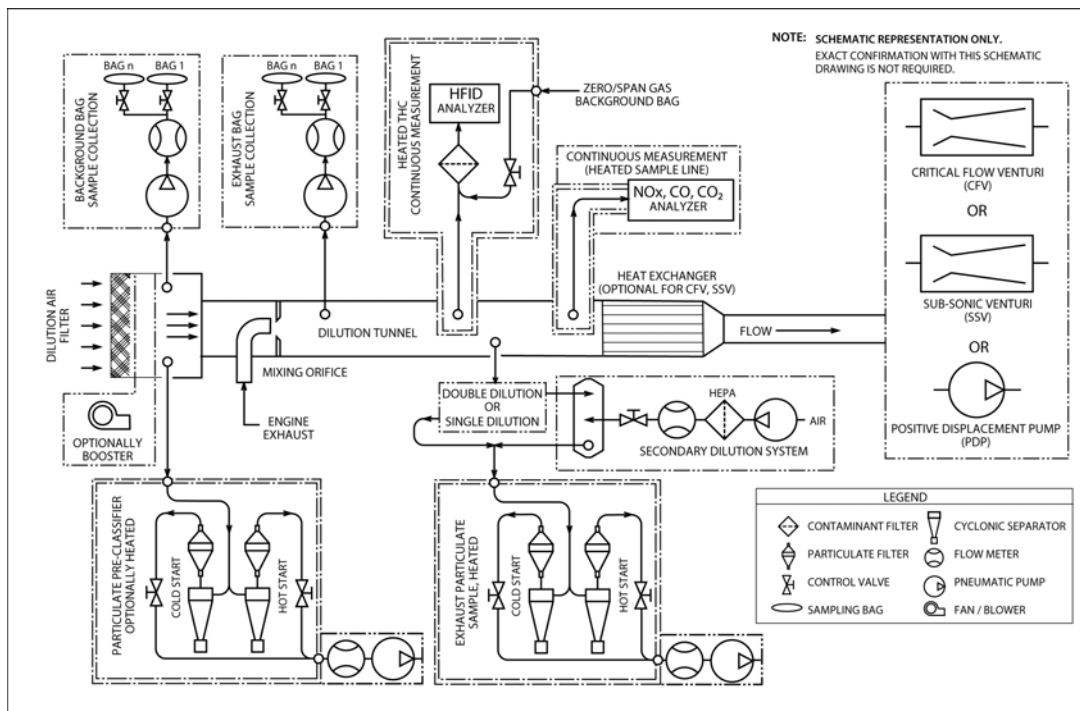

Figure 9.1 – Examples of full-flow dilution sampling configurations.

### 9.2.3. Partial flow dilution (PFD) system

#### 9.2.3.1. Description of partial flow system

A schematic of a PFD system is shown in figure 9.2. It is a general schematic showing principles of sample extraction, dilution and PM sampling. It is not meant to indicate that all the components described in the figure are necessary for other possible sampling systems that satisfy the intent of sample collection. Other configurations which do not match these schematics are allowed under the condition that they serve the same purpose of sample collection, dilution, and PM sampling. These need to satisfy other criteria such as in paragraphs 8.1.8.6. (periodic calibration) and 8.2.1.2. (validation) for varying dilution PFD, and paragraph 8.1.4.5 as well as table 8.2 (linearity verification) and paragraph 8.1.8.5.7. (verification) for constant dilution PFD.

As shown in figure 9.2, the raw exhaust gas or the primary diluted flow is transferred from the exhaust pipe EP or from CVS respectively to the dilution tunnel DT through the sampling probe SP and the transfer line TL. The total flow through the tunnel is adjusted with a flow controller and the sampling pump P of the particulate sampling system (PSS). For proportional raw exhaust sampling, the dilution air flow is controlled by the flow controller FC1, which may use  $q_{mew}$  (exhaust gas mass flow

rate on wet basis) or  $q_{maw}$  (intake air mass flow rate on wet basis) and  $q_{mf}$  (fuel mass flow rate) as command signals, for the desired exhaust split. The sample flow into the dilution tunnel DT is the difference of the total flow and the dilution air flow. The dilution air flow rate is measured with the flow measurement device FM1, the total flow rate with the flow measurement device of the particulate sampling system. The dilution ratio is calculated from these two flow rates. For sampling with a constant dilution ratio of raw or diluted exhaust versus exhaust flow (e.g.: secondary dilution for PM sampling), the dilution air flow rate is usually constant and controlled by the flow controller FC1 or dilution air pump.

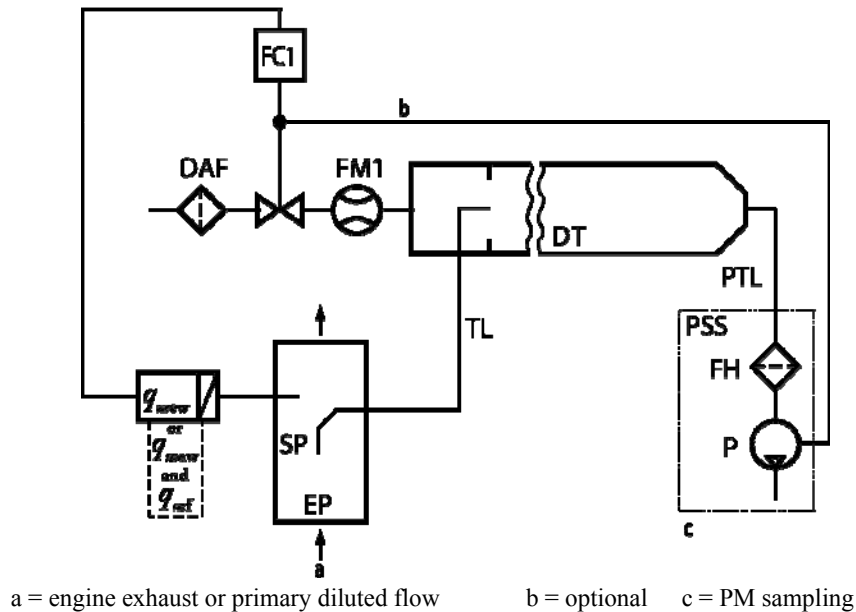

Figure 9.2. – Schematic of partial flow dilution system (total sampling type).

Components of figure 9.2:

DAF = Dilution air filter – The dilution air (ambient air, synthetic air, or nitrogen) shall be filtered with a high-efficiency PM air (HEPA) filter.

DT = Dilution tunnel or secondary dilution system

EP = Exhaust pipe or primary dilution system

FC1 = Flow controller

FH = Filter holder

FM1 = Flow measurement device measuring the dilution air flow rate

P = Sampling pump

PSS = PM sampling system

PTL = PM transfer line

SP = Raw or dilute exhaust gas sampling probe

TL = Transfer line

Mass flow rates applicable only for proportional raw exhaust sampling PFD:

$q_{mew}$  = Exhaust gas mass gas flow rate on wet basis

$q_{maw}$  = Intake air mass flow rate on wet basis

$q_{mf}$  = Fuel mass flow rate

#### 9.2.3.2. Dilution

The temperature of the diluents (ambient air, synthetic air, or nitrogen as quoted in paragraph 9.2.1.) shall be maintained within one of the following ranges (option):

(a) between 293 and 303 K (20 and 30 °C) or

(b) between 293 and 325 K (20 to 52°C)

in close proximity to the entrance into the dilution tunnel. The range shall be selected by the Contracting Party.

De-humidifying the dilution air before entering the dilution system is permitted. The partial flow dilution system has to be designed to extract a proportional raw exhaust sample from the engine exhaust stream, thus responding to excursions in the exhaust stream flow rate, and introduce dilution air to this sample to achieve a temperature at the test filter as prescribed by paragraph 9.3.3.4.3. For this it is essential that the dilution ratio be determined such that the accuracy requirements of paragraph 8.1.8.6.1. are fulfilled.

To ensure that a flow is measured that corresponds to a measured concentration, either aqueous condensation shall be prevented between the sample probe location and the flow meter inlet in the dilution tunnel or aqueous condensation shall be allowed to occur and humidity at the flow meter inlet measured. The PFD system may be heated or insulated to prevent aqueous condensation. Aqueous condensation shall be prevented throughout the dilution tunnel.

The minimum dilution ratio shall be within the range of 5:1 to 7:1 based on the maximum engine exhaust flow rate during the test cycle or test interval.

The residence time in the system shall be between 0.5 and 5 s, as measured from the point of diluent introduction to the filter holder(s).

To determine the mass of the particulates, a particulate sampling system, a particulate sampling filter, a gravimetric balance, and a temperature and humidity controlled weighing chamber, are required.

#### 9.2.3.3. Applicability

PFD may be used to extract a proportional raw exhaust sample for any batch or continuous PM and gaseous emission sampling over any transient duty cycle, any steady-state duty cycle or any ramped-modal duty cycle.

The system may be used also for a previously diluted exhaust where, via a constant dilution-ratio, an already proportional flow is diluted (see figure 9.2). This is the way of performing secondary dilution from a CVS tunnel to achieve the necessary overall dilution ratio for PM sampling.



9.2.3.4. Calibration

The calibration of the PFD to extract a proportional raw exhaust sample is considered in paragraph 8.1.8.6.

9.3. Sampling procedures

9.3.1 General sampling requirements

9.3.1.1. Probe design and construction

A probe is the first fitting in a sampling system. It protrudes into a raw or diluted exhaust stream to extract a sample, such that its inside and outside surfaces are in contact with the exhaust. A sample is transported out of a probe into a transfer line.

Sample probes shall be made with inside surfaces of stainless steel or, for raw exhaust sampling, with any non-reactive material capable of withstanding raw exhaust temperatures. Sample probes shall be located where constituents are mixed to their mean sample concentration and where interference with other probes is minimized. It is recommended that all probes remain free from influences of boundary layers, wakes, and eddies – especially near the outlet of a raw-exhaust tailpipe where unintended dilution might occur. Purging or back-flushing of a probe shall not influence another probe during testing. A single probe to extract a sample of more than one constituent may be used as long as the probe meets all the specifications for each constituent.

9.3.1.2. Transfer lines

Transfer lines that transport an extracted sample from a probe to an analyzer, storage medium, or dilution system shall be minimized in length by locating analyzers, storage media, and dilution systems as close to the probes as practical. The number of bends in transfer lines shall be minimized and that the radius of any unavoidable bend shall be maximized.

9.3.1.3. Sampling methods

For continuous and batch sampling, introduced in paragraph 7.2., the following conditions apply:

- (a) When extracting from a constant flow rate, the sample shall also be carried out at a constant flow rate.
- (b) When extracting from a varying flow rate, the sample flow rate shall be varied in proportion to the varying flow rate.
- (c) Proportional sampling shall be validated as described in paragraph 8.2.1.

### 9.3.2. Gas sampling

#### 9.3.2.1. Sampling probes

Either single-port or multi-port probes are used for sampling gaseous emissions. The probes may be oriented in any direction relative to the raw or diluted exhaust flow. For some probes, the sample temperatures shall be controlled, as follows:

- (a) For probes that extract  $\text{NO}_x$  from diluted exhaust, the probe's wall temperature shall be controlled to prevent aqueous condensation.
- (b) For probes that extract hydrocarbons from the diluted exhaust, a probe wall temperature is recommended to be controlled approximately 190 °C to minimise contamination.

#### 9.3.2.2. Transfer lines

Transfer lines with inside surfaces of stainless steel, PTFE, Viton<sup>TM</sup>, or any other material that has better properties for emission sampling shall be used. A non-reactive material capable of withstanding exhaust temperatures shall be used. In-line filters may be used if the filter and its housing meet the same temperature requirements as the transfer lines, as follows:

- (a) For  $\text{NO}_x$  transfer lines upstream of either an  $\text{NO}_2$ -to- $\text{NO}$  converter that meets the specifications of paragraph 8.1.11.5. or a chiller that meets the specifications of paragraph 8.1.11.4. a sample temperature that prevents aqueous condensation shall be maintained.
- (b) For THC transfer lines a wall temperature tolerance throughout the entire line of  $(191 \pm 11)$  °C shall be maintained. If sampled from raw exhaust, an unheated, insulated transfer line may be connected directly to a probe. The length and insulation of the transfer line shall be designed to cool the highest expected raw exhaust temperature to no lower than 191 °C, as measured at the transfer line outlet. For dilute sampling a transition zone between the probe and transfer line of up to 0.92 m in length is allowed to transition the wall temperature to  $(191 \pm 11)$  °C.

#### 9.3.2.3 Sample-conditioning components

##### 9.3.2.3.1. Sample dryers

###### 9.3.2.3.1.1. Requirements

The instrument that is used for removing moisture shall meet the minimum requirements in the following paragraph. The moisture content of 0.8 volume per cent  $\text{H}_2\text{O}$  is used in equation (A.8-14).

For the highest expected water vapour concentration  $H_m$ , the water removal technique shall maintain CLD humidity at  $\leq 5$  g water/kg dry air (or about 0.8 volume per cent  $\text{H}_2\text{O}$ ), which is 100 per cent relative humidity at 3.9 °C and 101.3 kPa. This humidity specification is also equivalent to about 25 per cent relative

humidity at 25 °C and 101.3 kPa. This may be demonstrated by measuring the temperature at the outlet of a thermal dehumidifier, or by measuring humidity at a point just upstream of the CLD.

9.3.2.3.1.2. Type of sample dryers allowed and procedure to estimate moisture content after the dryer

Either type of sample dryer described in this paragraph to decrease the effects of water on gaseous emission measurements may be used.

- (a) If an osmotic-membrane dryer upstream of any gaseous analyzer or storage medium is used, it shall meet the temperature specifications in paragraph 9.3.2.2. The dew point,  $T_{\text{dew}}$ , and absolute pressure,  $p_{\text{total}}$ , downstream of an osmotic-membrane dryer shall be monitored. The amount of water shall be calculated as specified in Annexes A.7-A.8 by using continuously recorded values of  $T_{\text{dew}}$  and  $p_{\text{total}}$  or their peak values observed during a test or their alarm set points. Lacking a direct measurement, the nominal  $p_{\text{total}}$  is given by the dryer's lowest absolute pressure expected during testing. The dew point,  $T_{\text{dew}}$ , and absolute pressure,  $p_{\text{total}}$ , downstream of a sample dryer shall be monitored.
- (b) A thermal chiller upstream of a THC measurement system for compression-ignition engines may not be used. If a thermal chiller upstream of an NO<sub>2</sub>-to-NO converter or in a sampling system without an NO<sub>2</sub>-to-NO converter is used, the chiller shall meet the NO<sub>2</sub> loss-performance check specified in paragraph 8.1.11.4. The dew point,  $T_{\text{dew}}$ , and absolute pressure,  $p_{\text{total}}$ , downstream of an osmotic-membrane dryer shall be monitored. The amount of water shall be calculated as specified in Annexes A.7-A.8 by using continuously recorded values of  $T_{\text{dew}}$  and  $p_{\text{total}}$  or their peak values observed during a test or their alarm set points. Lacking a direct measurement, the nominal  $p_{\text{total}}$  is given by the dryer's lowest absolute pressure expected during testing. The dew point,  $T_{\text{dew}}$ , and absolute pressure,  $p_{\text{total}}$ , downstream of a sample dryer shall be monitored. If it is valid to assume the degree of saturation in the thermal chiller,  $T_{\text{dew}}$  based on the known chiller efficiency and continuous monitoring of chiller temperature,  $T_{\text{chiller}}$  may be calculated. If values of  $T_{\text{chiller}}$  are not continuously recorded, its peak value observed during a test, or its alarm setpoint, may be used as a constant value to determine a constant amount of water according to Annexes A.7-A.8. If it is valid to assume that  $T_{\text{chiller}}$  is equal to  $T_{\text{dew}}$ ,  $T_{\text{chiller}}$  may be used in lieu of  $T_{\text{dew}}$  according to Annexes A.7-A.8. If it is valid to assume a constant temperature offset between  $T_{\text{chiller}}$  and  $T_{\text{dew}}$ , due to a known and fixed amount of sample reheat between the chiller outlet and the temperature measurement location, this assumed temperature offset value may be factored in into emission calculations. The validity of any assumptions allowed by this paragraph shall be shown by engineering analysis or by data.

9.3.2.3.2. Sample pumps

Sample pumps upstream of an analyzer or storage medium for any gas shall be used. Sample pumps with inside surfaces of stainless steel, PTFE, or any other material having better properties for emission sampling shall be used. For some sample pumps, temperatures shall be controlled, as follows:

- (a) If a NO<sub>x</sub> sample pump upstream of either an NO<sub>2</sub>-to-NO converter that meets paragraph 8.1.11.5. or a chiller that meets paragraph 8.1.11.4. is used, it shall be heated to prevent aqueous condensation.
- (b) If a THC sample pump upstream of a THC analyzer or storage medium is used, its inner surfaces shall be heated to a tolerance of (191 ±11) °C.

9.3.2.4. Sample storage media

In the case of bag sampling, gas volumes shall be stored in sufficiently clean containers that minimally off-gas or allow permeation of gases. Good engineering judgment shall be used to determine acceptable thresholds of storage media cleanliness and permeation. To clean a container, it may be repeatedly purged and evacuated and may be heated. A flexible container (such as a bag) within a temperature-controlled environment, or a temperature controlled rigid container that is initially evacuated or has a volume that can be displaced, such as a piston and cylinder arrangement, shall be used. Containers meeting the specifications in the following table 9.1 shall be used.

CO, CO <sub>2</sub> , O <sub>2</sub> , CH <sub>4</sub> , C <sub>2</sub> H <sub>6</sub> , C <sub>3</sub> H <sub>8</sub> , NO, NO <sub>2</sub> <sup>1</sup>	Tedlar™, <sup>2</sup> Kynar™, <sup>2</sup> Teflon™, <sup>3</sup> or stainless steel <sup>3</sup>
THC, NMHC	Teflon™ <sup>4</sup> or stainless steel <sup>4</sup>
<sup>1</sup> As long as aqueous condensation in storage container is prevented. <sup>2</sup> Up to 40 °C. <sup>3</sup> Up to 202 °C. <sup>4</sup> At (191 ±11) °C.	

Table 9.1 – Gaseous Batch Sampling Container Materials

9.3.3. PM sampling

9.3.3.1. Sampling probes

PM probes with a single opening at the end shall be used. PM probes shall be oriented to face directly upstream.

The PM probe may be shielded with a hat that conforms with the requirements in figure 9.3. In this case the pre-classifier described in paragraph 9.3.3.3. shall not be used.

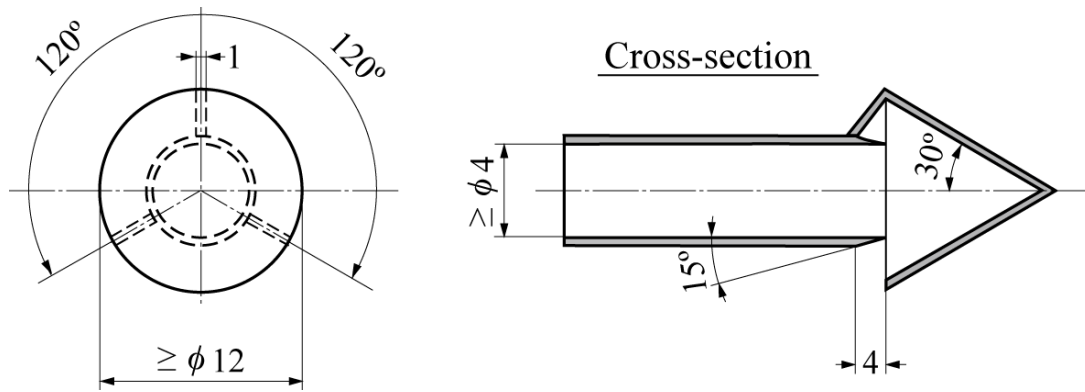

Figure 9.3 – Scheme of a sampling probe with a hat-shaped pre-classifier

#### 9.3.3.2. Transfer lines

Insulated or heated transfer lines or a heated enclosure are recommended to minimize temperature differences between transfer lines and exhaust constituents. Transfer lines that are inert with respect to PM and are electrically conductive on the inside surfaces shall be used. It is recommended using PM transfer lines made of stainless steel; any material other than stainless steel will be required to meet the same sampling performance as stainless steel. The inside surface of PM transfer lines shall be electrically grounded.

#### 9.3.3.3. Pre-classifier

The use of a PM pre-classifier to remove large-diameter particles is permitted that is installed in the dilution system directly before the filter holder. Only one pre-classifier is permitted. If a hat shaped probe is used (see figure 9.3), the use of a pre-classifier is prohibited.

The PM pre-classifier may be either an inertial impactor or a cyclonic separator. It shall be constructed of stainless steel. The pre-classifier shall be rated to remove at least 50 per cent of PM at an aerodynamic diameter of 10  $\mu\text{m}$  and no more than 1 per cent of PM at an aerodynamic diameter of 1  $\mu\text{m}$  over the range of flow rates for which it is used. The pre-classifier outlet shall be configured with a means of bypassing any PM sample filter so that the pre-classifier flow can be stabilized before starting a test. PM sample filter shall be located within 75 cm downstream of the pre-classifier's exit.

#### 9.3.3.4. Sample filter

The diluted exhaust shall be sampled by a filter that meets the requirements of paragraphs 9.3.3.4.1. to 9.3.3.4.4. during the test sequence.

#### 9.3.3.4.1. Filter specification

All filter types shall have a 0.3 µm DOP (di-octylphthalate) collection efficiency of at least 99.7 per cent. The sample filter manufacturer's measurements reflected in their product ratings may be used to show this requirement. The filter material shall be either:

- (a) fluorocarbon (PTFE) coated glass fibre, or
- (b) fluorocarbon (PTFE) membrane.

If the expected net PM mass on the filter exceeds 400 µg, a filter with a minimum initial collection efficiency of 98 per cent may be used.

#### 9.3.3.4.2. Filter size

The nominal filter size shall be 46.50 mm ± 0.6 mm diameter.

#### 9.3.3.4.3. Dilution and temperature control of PM samples

PM samples shall be diluted at least once upstream of transfer lines in case of a CVS system and downstream in case of PFD system (see 9.3.3.2. relating to transfer lines). Sample temperature is to be controlled to a (47 ± 5) °C tolerance, as measured anywhere within 200 mm upstream or 200 mm downstream of the PM storage media. The PM sample is intended to be heated or cooled primarily by dilution conditions as specified in paragraph 9.2.1.(a).

#### 9.3.3.4.4. Filter face velocity

A filter face velocity shall be between 0.90 and 1.00 m/s with less than 5 per cent of the recorded flow values exceeding this range. If the total PM mass exceeds 400 µg, the filter face velocity may be reduced. The face velocity shall be measured as the volumetric flow rate of the sample at the pressure upstream of the filter and temperature of the filter face, divided by the filter's exposed area. The exhaust stack or CVS tunnel pressure shall be used for the upstream pressure if the pressure drop through the PM sampler up to the filter is less than 2 kPa.

#### 9.3.3.4.5 Filter holder

To minimize turbulent deposition and to deposit PM evenly on a filter, a 12.5° (from centre) divergent cone angle to transition from the transfer-line inside diameter to the exposed diameter of the filter face shall be used. Stainless steel for this transition shall be used.

9.3.4. PM-stabilization and weighing environments for gravimetric analysis

9.3.4.1. Environment for gravimetric analysis

This section describes the two environments required to stabilize and weigh PM for gravimetric analysis: the PM stabilization environment, where filters are stored before weighing; and the weighing environment, where the balance is located. The two environments may share a common space.

Both the stabilization and the weighing environments shall be kept free of ambient contaminants, such as dust, aerosols, or semi-volatile material that could contaminate PM samples.

9.3.4.2. Cleanliness

The cleanliness of the PM-stabilization environment using reference filters shall be verified, as described in paragraph 8.1.12.1.4.

9.3.4.3. Temperature of the chamber

The temperature of the chamber (or room) in which the particulate filters are conditioned and weighed shall be maintained to within  $22\text{ }^{\circ}\text{C} \pm 1\text{ }^{\circ}\text{C}$  during all filter conditioning and weighing. The humidity shall be maintained to a dew point of  $9.5\text{ }^{\circ}\text{C} \pm 1\text{ }^{\circ}\text{C}$  and a relative humidity of 45 per cent  $\pm$  8 per cent. If the stabilization and weighing environments are separate, the stabilization environment shall be maintained at a tolerance of  $22\text{ }^{\circ}\text{C} \pm 3\text{ }^{\circ}\text{C}$ .

9.3.4.4. Verification of ambient conditions

When using measurement instruments that meet the specifications in paragraph 9.4 the following ambient conditions shall be verified:

- (a) Dew point and ambient temperature shall be recorded. These values shall be used to determine if the stabilization and weighing environments have remained within the tolerances specified in paragraph 9.3.4.3. of this section for at least 60 min before weighing filters.
- (b) Atmospheric pressure shall be continuously recorded within the weighing environment. An acceptable alternative is to use a barometer that measures atmospheric pressure outside the weighing environment, as long as it can be ensured that the atmospheric pressure at the balance is always at the balance within  $\pm 100\text{ Pa}$  of the shared atmospheric pressure. A means to record the most recent atmospheric pressure shall be provided when each PM sample is weighed. This value shall be used to calculate the PM buoyancy correction in paragraph 8.1.12.2.

#### 9.3.4.5. Installation of balance

The balance shall be installed as follows:

- (a) installed on a vibration-isolation platform to isolate it from external noise and vibration,
- (b) shielded from convective airflow with a static-dissipating draft shield that is electrically grounded.

#### 9.3.4.6. Static electric charge

Static electric charge shall be minimized in the balance environment, as follows:

- (a) The balance is electrically grounded.
- (b) Stainless steel tweezers shall be used if PM samples shall be handled manually.
- (c) Tweezers shall be grounded with a grounding strap, or a grounding strap shall be provided for the operator such that the grounding strap shares a common ground with the balance.
- (d) A static-electricity neutralizer shall be provided that is electrically grounded in common with the balance to remove static charge from PM samples.

### 9.4. Measurement instruments

#### 9.4.1. Introduction

##### 9.4.1.1. Scope

This paragraph specifies measurement instruments and associated system requirements related to emission testing. This includes laboratory instruments for measuring engine parameters, ambient conditions, flow-related parameters, and emission concentrations (raw or diluted).

##### 9.4.1.2. Instrument types

Any instrument mentioned in this gtr shall be used as described in the gtr itself (see Table 8.2 for measurement quantities provided by these instruments). Whenever an instrument mentioned in this gtr is used in a way that is not specified, or another instrument is used in its place, the requirements for equivalency provisions shall apply as specified in paragraph 5.1.3. Where more than one instrument for a particular measurement is specified, one of them will be identified by the type approval or certifying authority upon application as the reference for showing that an alternative procedure is equivalent to the specified procedure.

##### 9.4.1.3. Redundant systems

Data from multiple instruments to calculate test results for a single test may be used for all measurement instruments described in this paragraph, with prior approval of the type approval or certification authority. Results from all measurements shall be recorded and the raw data shall be retained, as described in paragraph 5.3. This



requirement applies whether or not the measurements are actually used in the calculations.

#### 9.4.2. Data recording and control

The test system shall be able to update data, record data and control systems related to operator demand, the dynamometer, sampling equipment, and measurement instruments. Data acquisition and control systems shall be used that can record at the specified minimum frequencies, as shown in table 9.2 (this table does not apply to discrete mode testing).

Applicable Test Protocol Section	Measured Values	Minimum Command and Control Frequency	Minimum Recording Frequency
7.6.	Speed and torque during an engine step-map	1 Hz	1 mean value per step
7.6.	Speed and torque during an engine sweep-map	5 Hz	1 Hz means
7.8.3.	Transient duty cycle reference and feedback speeds and torques	5 Hz	1 Hz means
7.8.2.	Steady-state and ramped-modal duty cycle reference and feedback speeds and torques	1 Hz	1 Hz
7.3.	Continuous concentrations of raw analyzers	N/A	1 Hz
7.3.	Continuous concentrations of dilute analyzers	N/A	1 Hz
7.3.	Batch concentrations of raw or dilute analyzers	N/A	1 mean value per test interval
7.6. 8.2.1.	Diluted exhaust flow rate from a CVS with a heat exchanger upstream of the flow measurement	N/A	1 Hz
7.6. 8.2.1.	Diluted exhaust flow rate from a CVS without a heat exchanger upstream of the flow measurement	5 Hz	1 Hz means
7.6. 8.2.1.	Intake-air or exhaust flow rate (for raw transient measurement)	N/A	1 Hz means
7.6. 8.2.1.	Dilution air if actively controlled	5 Hz	1 Hz means
7.6. 8.2.1.	Sample flow from a CVS with a heat exchanger	1 Hz	1 Hz
7.6. 8.2.1.	Sample flow from a CVS without a heat exchanger	5 Hz	1 Hz mean

Table 9.2 – Data recording and control minimum frequencies

#### 9.4.3. Performance specifications for measurement instruments

##### 9.4.3.1. Overview

The test system as a whole shall meet all the applicable calibrations, verifications, and test-validation criteria specified in paragraphs 8.1., including the requirements of the linearity check of paragraphs 8.1.4. and 8.2. Instruments shall meet the specifications in table 9.2 for all ranges to be used for testing. Furthermore, any documentation received from instrument manufacturers showing that instruments meet the specifications in table 9.2 shall be kept.

#### 9.4.3.2. Component requirements

Table 9.3 shows the specifications of transducers of torque, speed, and pressure, sensors of temperature and dew point, and other instruments. The overall system for measuring the given physical and/or chemical quantity shall meet the linearity verification in paragraph 8.1.4. For gaseous emissions measurements, analyzers may be used, that have compensation algorithms that are functions of other measured gaseous components, and of the fuel properties for the specific engine test. Any compensation algorithm shall only provide offset compensation without affecting any gain (that is no bias).

Measurement Instrument	Measured quantity symbol	Complete System Rise time	Recording update frequency	Accuracy <sup>(a)</sup>	Repeatability <sup>(a)</sup>
Engine speed transducer	<i>n</i>	1 s	1 Hz means	2.0 % of pt. or 0.5 % of max	1.0 % of pt. or 0.25 % of max
Engine torque transducer	<i>T</i>	1 s	1 Hz means	2.0 % of pt. or 1.0 % of max	1.0 % of pt. or 0.5 % of max
Fuel flow meter (Fuel totalizer)		5 s (N/A)	1 Hz (N/A)	2.0 % of pt. or 1.5 % of max	1.0 % of pt. or 0.75 % of max
Total diluted exhaust meter (CVS) (With heat exchanger before meter)		1 s (5 s)	1 Hz means (1 Hz)	2.0 % of pt. or 1.5 % of max	1.0 % of pt. or 0.75 % of max
Dilution air, inlet air, exhaust, and sample flow meters		1 s	1 Hz means of 5 Hz samples	2.5 % of pt. or 1.5 % of max	1.25 % of pt. or 0.75 % of max
Continuous gas analyzer raw	<i>X</i>	2.5 s	2 Hz	2.0 % of pt. or 2.0 % of meas.	1.0 % of pt. or 1.0 % of meas.
Continuous gas analyzer dilute	<i>X</i>	5 s	1 Hz	2.0 % of pt. or 2.0 % of meas.	1.0 % of pt. or 1.0 % of meas.
Continuous gas analyzer	<i>X</i>	5 s	1 Hz	2.0 % of pt. or 2.0 % of meas.	1.0 % of pt. or 1.0 % of meas.
Batch gas analyzer	<i>X</i>	N/A	N/A	2.0 % of pt. or 2.0 % of meas.	1.0 % of pt. or 1.0 % of meas.
Gravimetric PM balance	<i>m</i> <sub>PM</sub>	N/A	N/A	See 9.4.11.	0.5 µg
Inertial PM balance	<i>m</i> <sub>PM</sub>	5 s	1 Hz	2.0 % of pt. or 2.0 % of meas.	1.0 % of pt. or 1.0 % of meas.

<sup>(a)</sup> Accuracy and repeatability are all determined with the same collected data, as described in §9.4.3., and based on absolute values. "pt." refers to the overall mean value expected at the emission limit ; "max." refers to the peak value expected at the emission limit over the duty cycle , not the maximum of the instrument's range; "meas." refers to the actual mean measured over the duty cycle .

Table 9.3 – Recommended performance specifications for measurement instruments

9.4.4. Measurement of engine parameters & ambient conditions

9.4.4.1. Speed and torque sensors

9.4.4.1.1. Application

Measurement instruments for work inputs and outputs during engine operation shall meet the specifications in this paragraph. Sensors, transducers, and meters meeting the specifications in table 9.3 are recommended. Overall systems for measuring work inputs and outputs shall meet the linearity verifications in paragraph 8.1.4.

9.4.4.1.2. Shaft work

Work and power shall be calculated from outputs of speed and torque transducers according to paragraph 9.4.4.1. Overall systems for measuring speed and torque shall meet the calibration and verifications in paragraphs 8.1.7. and 8.1.4.

Torque induced by the inertia of accelerating and decelerating components connected to the flywheel, such as the drive shaft and dynamometer rotor, shall be compensated for.

9.4.4.2. Pressure transducers, temperature sensors, and dew point sensors

Overall systems for measuring pressure, temperature, and dew point shall meet the calibration in paragraph 8.1.7.

Pressure transducers shall be located in a temperature-controlled environment, or they shall compensate for temperature changes over their expected operating range. Transducer materials shall be compatible with the fluid being measured.

9.4.5. Flow-related measurements

For any type of flow meter (of fuel, intake-air, raw exhaust, diluted exhaust, sample), the flow shall be conditioned as needed to prevent wakes, eddies, circulating flows, or flow pulsations from affecting the accuracy or repeatability of the meter. For some meters, this may be accomplished by using a sufficient length of straight tubing (such as a length equal to at least 10 pipe diameters) or by using specially designed tubing bends, straightening fins, orifice plates (or pneumatic pulsation dampeners for the fuel flow meter) to establish a steady and predictable velocity profile upstream of the meter.

9.4.5.1 Fuel flow meter

Overall system for measuring fuel flow shall meet the calibration in paragraph 8.1.8.1. In any fuel flow measurement it shall be accounted for any fuel that bypasses the engine or returns from the engine to the fuel storage tank.

9.4.5.2. Intake-air flow meter

Overall system for measuring intake-air flow shall meet the calibration in paragraph 8.1.8.2.

9.4.5.3. Raw exhaust flow meter

9.4.5.3.1. Component requirements

The overall system for measuring raw exhaust flow shall meet the linearity requirements in paragraph 8.1.4. Any raw-exhaust meter shall be designed to appropriately compensate for changes in the raw exhaust's thermodynamic, fluid, and compositional states.

9.4.5.3.2. Flow meter response time

For the purpose of controlling of a partial flow dilution system to extract a proportional raw exhaust sample, a flow meter response time faster than indicated in table 9.2 is required. For partial flow dilution systems with online control, the flow meter response time shall meet the specifications of paragraph 8.2.1.2.

9.4.5.3.3. Exhaust cooling

Exhaust cooling upstream of the flow meter is permitted with the following restrictions:

- (a) PM shall not be sampled downstream of the cooling.
- (b) If cooling causes exhaust temperatures above 202 °C to decrease to below 180 °C, NMHC shall not be sampled downstream of the cooling.
- (c) If cooling causes aqueous condensation, NO<sub>x</sub> shall not be sampled downstream of the cooling unless the cooler meets the performance verification in paragraph 8.1.11.4.
- (d) If cooling causes aqueous condensation before the flow reaches a flow meter,  $T_{\text{dew}}$  and pressure  $p_{\text{total}}$  shall be measured at the flow meter inlet. These values shall be used in emission calculations according to Annexes A.7-A.8.

9.4.5.4. Dilution air and diluted exhaust flow meters

9.4.5.4.1. Application

Instantaneous diluted exhaust flow rates or total diluted exhaust flow over a test interval shall be determined by using a diluted exhaust flow meter. Raw exhaust flow rates or total raw exhaust flow over a test interval may be calculated from the difference between a diluted exhaust flow meter and a dilution air meter.

#### 9.4.5.4.2. Component requirements

The overall system for measuring diluted exhaust flow shall meet the calibration and verifications in paragraphs 8.1.8.4. and 8.1.8.5. The following meters may be used:

- (a) For constant-volume sampling (CVS) of the total flow of diluted exhaust, a critical-flow venturi (CFV) or multiple critical-flow venturis arranged in parallel, a positive-displacement pump (PDP), a subsonic venturi (SSV), or an ultrasonic flow meter (UFM) may be used. Combined with an upstream heat exchanger, either a CFV or a PDP will also function as a passive flow controller by keeping the diluted exhaust temperature constant in a CVS system.
- (b) For the Partial Flow Dilution (PFD) system the combination of any flow meter with any active flow control system to maintain proportional sampling of exhaust constituents may be used. The total flow of diluted exhaust, or one or more sample flows, or a combination of these flow controls may be controlled to maintain proportional sampling.

For any other dilution system, a laminar flow element, an ultrasonic flow meter, a subsonic venturi, a critical-flow venturi or multiple critical-flow venturis arranged in parallel, a positive-displacement meter, a thermal-mass meter, an averaging Pitot tube, or a hot-wire anemometer may be used.

#### 9.4.5.4.3. Exhaust cooling

Diluted exhaust upstream of a dilute flow meter may be cooled, as long as all the following provisions are observed:

- (a) PM shall not be sampled downstream of the cooling.
- (b) If cooling causes exhaust temperatures above 202 °C to decrease to below 180 °C, NMHC shall not be sampled downstream of the cooling.
- (c) If cooling causes aqueous condensation, NO<sub>x</sub> shall not be sampled downstream of the cooling unless the cooler meets the performance verification in paragraph 8.1.11.4.
- (d) If cooling causes aqueous condensation before the flow reaches a flow meter, dew point,  $T_{\text{dew}}$  and pressure  $p_{\text{total}}$  shall be measured at the flow meter inlet. These values shall be used in emission calculations according Annexes A.7-A.8.

#### 9.4.5.5. Sample flow meter for batch sampling

A sample flow meter shall be used to determine sample flow rates or total flow sampled into a batch sampling system over a test interval. The difference between two flow meters may be used to calculate sample flow into a dilution tunnel e.g. for partial flow dilution PM measurement and secondary dilution flow PM measurement. Specifications for differential flow measurement to extract a proportional raw exhaust sample is given in paragraph 8.1.8.6.1. and the calibration of differential flow measurement is given in paragraph 8.1.8.6.2.

Overall system for the sample flow meter shall meet the calibration in paragraph 8.1.8.

9.4.5.6. Gas divider

A gas divider may be used to blend calibration gases.

A gas divider shall be used that blends gases to the specifications of paragraph 9.5.1. and to the concentrations expected during testing. Critical-flow gas dividers, capillary-tube gas dividers, or thermal-mass-meter gas dividers may be used. Viscosity corrections shall be applied as necessary (if not done by gas divider internal software) to appropriately ensure correct gas division. The gas-divider system shall meet the linearity verification in paragraph 8.1.4.5. Optionally, the blending device may be checked with an instrument which by nature is linear, e.g. using NO gas with a CLD. The span value of the instrument shall be adjusted with the span gas directly connected to the instrument. The gas divider shall be checked at the settings used and the nominal value shall be compared to the measured concentration of the instrument.

9.4.6. CO and CO<sub>2</sub> measurements

A Non-dispersive infrared (NDIR) analyzer shall be used to measure CO and CO<sub>2</sub> concentrations in raw or diluted exhaust for either batch or continuous sampling.

The NDIR-based system shall meet the calibration and verifications in paragraph 8.1.8.1.

9.4.7. Hydrocarbon measurements

9.4.7.1. Flame-ionization detector

9.4.7.1.1. Application

A heated flame-ionization detector (FID) analyzer shall be used to measure hydrocarbon concentrations in raw or diluted exhaust for either batch or continuous sampling. Hydrocarbon concentrations shall be determined on a carbon number basis of one, C<sub>1</sub>. Methane and non-methane hydrocarbon values shall be determined as described in paragraph 9.4.7.1.4. Heated FID analyzers shall maintain all surfaces that are exposed to emissions at a temperature of 191 ±11 °C.

9.4.7.1.2. Component requirements

The FID-based system for measuring THC or CH<sub>4</sub> shall meet all of the verifications for hydrocarbon measurement in paragraph 8.1.10.

9.4.7.1.3. FID fuel and burner air

FID fuel and burner air shall meet the specifications of paragraph 9.5.1. The FID fuel and burner air shall not mix before entering the FID analyzer to ensure that the FID analyzer operates with a diffusion flame and not a premixed flame.

9.4.7.1.4. Methane

FID analyzers measure total hydrocarbons (THC). To determine non-methane hydrocarbons (NMHC), methane, CH<sub>4</sub>, shall be quantified either with a non-methane cutter and a FID analyzer as described in paragraph 9.4.7.2., or with a gas chromatograph as described in paragraph 9.4.7.3. For a FID analyzer used to determine NMHC, its response factor to CH<sub>4</sub>,  $RF_{CH_4}$ , shall be determined as described in paragraph 8.1.10.1. NMHC-related calculations are described in Annexes A.7-A.8.

9.4.7.1.5. Assumption on methane

Instead of measuring methane, it is allowed to assume that 2 per cent of measured total hydrocarbons is methane, as described in Annexes A.7-A.8.

9.4.7.2. Non-methane cutter

9.4.7.2.1. Application

A non-methane cutter may be used to measure CH<sub>4</sub> with a FID analyzer. A non-methane cutter oxidizes all non-methane hydrocarbons to CO<sub>2</sub> and H<sub>2</sub>O. A non-methane cutter may be used for raw or diluted exhaust for batch or continuous sampling.

9.4.7.2.2. System performance

Non-methane-cutter performance shall be determined as described in paragraph 8.1.10.3. and the results shall be used to calculate NMHC emission in A.7. and A.8.

9.4.7.2.3. Configuration

The non-methane cutter shall be configured with a bypass line for the verification described in paragraph 8.1.10.3.

9.4.7.2.4. Optimization

A non-methane cutter may be optimised to maximize the penetration of CH<sub>4</sub> and the oxidation of all other hydrocarbons. A sample may be humidified and a sample may be diluted with purified air or oxygen (O<sub>2</sub>) upstream of non-methane cutter to



optimize its performance. Any sample humidification and dilution shall be accounted for in emission calculations.

9.4.7.3. Gas chromatograph

Application: A gas chromatograph may be used to measure CH<sub>4</sub> concentrations of diluted exhaust for batch sampling. While also a non-methane cutter may be used to measure CH<sub>4</sub>, as described in paragraph 9.4.7.2. a reference procedure based on a gas chromatograph shall be used for comparison with any proposed alternate measurement procedure under paragraph 5.3.

9.4.8. NO<sub>x</sub> measurements

Two measurement instruments are specified for NO<sub>x</sub> measurement and either instrument may be used provided it meets the criteria specified in paragraph 9.4.8.1. or 9.4.8.2., respectively. The chemiluminescent detector shall be used as the reference procedure for comparison with any proposed alternate measurement procedure under paragraph 5.3.

9.4.8.1. Chemiluminescent detector

9.4.8.1.1. Application

A chemiluminescent detector (CLD) coupled with an NO<sub>2</sub>-to-NO converter is used to measure NO<sub>x</sub> concentration in raw or diluted exhaust for batch or continuous sampling.

9.4.8.1.2. Component requirements

The CLD-based system shall meet the quench verification in paragraph 8.1.11.1. A heated or unheated CLD may be used, and a CLD that operates at atmospheric pressure or under a vacuum may be used.

9.4.8.1.3. NO<sub>2</sub>-to-NO converter

An internal or external NO<sub>2</sub>-to-NO converter that meets the verification in paragraph 8.1.11.5. shall be placed upstream of the CLD, while the converter shall be configured with a bypass to facilitate this verification.

9.4.8.1.4. Humidity effects

All CLD temperatures shall be maintained to prevent aqueous condensation. To remove humidity from a sample upstream of a CLD, one of the following configurations shall be used:

- (a) A CLD connected downstream of any dryer or chiller that is downstream of an NO<sub>2</sub>-to-NO converter that meets the verification in paragraph 8.1.11.5.

- (b) A CLD connected downstream of any dryer or thermal chiller that meets the verification in paragraph 8.1.11.4.

#### 9.4.8.1.5. Response time

A heated CLD may be used to improve CLD response time.

#### 9.4.8.2. Non-dispersive ultraviolet analyzer

##### 9.4.8.2.1. Application

A non-dispersive ultraviolet (NDUV) analyzer is used to measure NO<sub>x</sub> concentration in raw or diluted exhaust for batch or continuous sampling.

##### 9.4.8.2.2. Component requirements

The NDUV-based system shall meet the verifications in paragraph 8.1.11.3.

##### 9.4.8.2.3. NO<sub>2</sub>-to-NO converter

If the NDUV analyzer measures only NO, an internal or external NO<sub>2</sub>-to-NO converter that meets the verification in paragraph 8.1.11.5. shall be placed upstream of the NDUV analyzer. The converter shall be configured with a bypass to facilitate this verification.

##### 9.4.8.2.4. Humidity effects

The NDUV temperature shall be maintained to prevent aqueous condensation, unless one of the following configurations is used:

- (a) An NDUV shall be connected downstream of any dryer or chiller that is downstream of an NO<sub>2</sub>-to-NO converter that meets the verification in paragraph 8.1.11.5.
- (b) An NDUV shall be connected downstream of any dryer or thermal chiller that meets the verification in paragraph 8.1.11.4.

#### 9.4.9. O<sub>2</sub> measurements

A paramagnetic detection (PMD) or magneto pneumatic detection (MPD) analyzer shall be used to measure O<sub>2</sub> concentration in raw or diluted exhaust for batch or continuous sampling.

#### 9.4.10. Air-to-fuel ratio measurements

A Zirconia (ZrO<sub>2</sub>) analyser may be used to measure air-to-fuel ratio in raw exhaust for continuous sampling. O<sub>2</sub> measurements with intake air or fuel flow measurements may be used to calculate exhaust flow rate according to Annexes A.7-A.8.

9.4.11. PM measurements with gravimetric balance

A balance shall be used to weigh net PM collected on sample filter media.

The minimum requirement on the balance resolution shall be equal or lower than the repeatability of 0.5 microgram recommended in table 9.3. If the balance uses internal calibration weights for routine spanning and linearity verifications, the calibration weights shall meet the specifications in paragraph 9.5.2.

The balance shall be configured for optimum settling time and stability at its location.

9.5. Analytical gases and mass standards

9.5.1. Analytical gases

Analytical gases shall meet the accuracy and purity specifications of this section.

9.5.1.1. Gas specifications

The following gas specifications shall be considered:

- (a) Purified gases shall be used to zero measurement instruments and to blend with calibration gases. Gases with contamination no higher than the highest of the following values in the gas cylinder or at the outlet of a zero-gas generator shall be used:
  - (i) 2 per cent contamination, measured relative to the mean concentration expected at the standard. For example, if a CO concentration of 100.0  $\mu\text{mol/mol}$  is expected, then it would be allowed to use a zero gas with CO contamination less than or equal to 2.000  $\mu\text{mol/mol}$ .
  - (ii) Contamination as specified in table 9.4, applicable for raw or dilute measurements
  - (iii) Contamination as specified in table 9.5, applicable for raw measurements

Constituent	Purified Synthetic Air <sup>a</sup>	Purified N <sub>2</sub> <sup>a</sup>
THC (C <sub>1</sub> equivalent)	< 0.05 $\mu\text{mol/mol}$	< 0.05 $\mu\text{mol/mol}$
CO	< 1 $\mu\text{mol/mol}$	< 1 $\mu\text{mol/mol}$
CO <sub>2</sub>	< 10 $\mu\text{mol/mol}$	< 10 $\mu\text{mol/mol}$
O <sub>2</sub>	0.205 to 0.215 mol/mol	< 2 $\mu\text{mol/mol}$
NO <sub>x</sub>	< 0.02 $\mu\text{mol/mol}$	< 0.02 $\mu\text{mol/mol}$

<sup>a</sup> It is not required that these levels of purity are international and/or national recognized standards-traceable.

Table 9.4: Contamination limits, applicable for raw or dilute measurements [ $\mu\text{mol/mol}$  = ppm (3.2.)]

Constituent	Purified Synthetic Air <sup>a</sup>	Purified N <sub>2</sub> <sup>a</sup>
THC (C <sub>1</sub> equivalent)	≤ 1 μmol/mol	≤ 1 μmol/mol
CO	≤ 1 μmol/mol	≤ 1 μmol/mol
CO <sub>2</sub>	≤ 400 μmol/mol	≤ 400 μmol/mol
O <sub>2</sub>	0.18 to 0.21 mol/mol	-
NO <sub>x</sub>	≤ 0.1 μmol/mol	≤ 0.1 μmol/mol

<sup>a</sup> It is not required that these levels of purity are international and/or national recognized standards traceable.

Table 9.5: Contamination limits applicable for raw measurements  
[μmol/mol = ppm (3.2.)]

- (b) The following gases shall be used with a FID analyzer:
- (i) FID fuel shall be used with an H<sub>2</sub> concentration of (0.39 to 0.41) mol/mol, balance He. The mixture shall not contain more than 0.05 μmol/mol THC.
  - (ii) FID burner air shall be used that meets the specifications of purified air in paragraph (a) of this paragraph.
  - (iii) FID zero gas. Flame-ionization detectors shall be zeroed with purified gas that meets the specifications in paragraph (a) of this paragraph, except that the purified gas O<sub>2</sub> concentration may be any value.
  - (iv) FID propane span gas. The THC FID shall be spanned and calibrated with span concentrations of propane, C<sub>3</sub>H<sub>8</sub>. It shall be calibrated on a carbon number basis of one (C<sub>1</sub>).
  - (v) FID methane span gas. If a CH<sub>4</sub> FID is always spanned and calibrated with a non-methane cutter, then the FID shall be spanned and calibrated with span concentrations of methane, CH<sub>4</sub>. It shall be calibrated on a carbon number basis of one (C<sub>1</sub>).
- (c) The following gas mixtures shall be used, with gases traceable within ±1.0 per cent of the international and/or national recognized standards true value or of other gas standards that are approved:
- (i) CH<sub>4</sub>, balance purified synthetic air and/or N<sub>2</sub> (as applicable).
  - (ii) C<sub>2</sub>H<sub>6</sub>, balance purified synthetic air and/or N<sub>2</sub> (as applicable).
  - (iii) C<sub>3</sub>H<sub>8</sub>, balance purified synthetic air and/or N<sub>2</sub> (as applicable).
  - (iv) CO, balance purified N<sub>2</sub>.
  - (v) CO<sub>2</sub>, balance purified N<sub>2</sub>.
  - (vi) NO, balance purified N<sub>2</sub>.
  - (vii) NO<sub>2</sub>, balance purified synthetic air.
  - (viii) O<sub>2</sub>, balance purified N<sub>2</sub>.
  - (ix) C<sub>3</sub>H<sub>8</sub>, CO, CO<sub>2</sub>, NO, balance purified N<sub>2</sub>.
  - (x) C<sub>3</sub>H<sub>8</sub>, CH<sub>4</sub>, CO, CO<sub>2</sub>, NO, balance purified N<sub>2</sub>.
- (d) Gases for species other than those listed in paragraph (c) of this paragraph may be used (such as methanol in air, which may be used to determine response factors), as long as they are traceable to within ±3.0 per cent of the international and/or national recognized standards true value, and meet the stability requirements of paragraph 9.5.1.2.

- (e) Own calibration gases may be generated using a precision blending device, such as a gas divider, to dilute gases with purified N<sub>2</sub> or purified synthetic air. If the gas dividers meet the specifications in paragraph 9.4.5.6, and the gases being blended meet the requirements of paragraphs (a) and (c) of this paragraph, the resulting blends are considered to meet the requirements of this paragraph 9.5.1.1.

9.5.1.2. Concentration and expiration date

The concentration of any calibration gas standard and its expiration date specified by the gas supplier shall be recorded.

- (a) No calibration gas standard may be used after its expiration date, except as allowed by paragraph (b) of this paragraph.
- (b) Calibration gases may be relabelled and used after their expiration date if it is approved in advance by type approval or certification authority.

9.5.1.3. Gas transfer

Gases shall be transferred from their source to analyzers using components that are dedicated to controlling and transferring only those gases.

The shelf life of all calibration gases shall be respected. The expiration date of the calibration gases stated by the manufacturer shall be recorded.

9.5.2. Mass standards

PM balance calibration weights that are certified as international and/or national recognized standards-traceable within 0.1 per cent uncertainty shall be used. Calibration weights may be certified by any calibration lab that maintains international and/or national recognized standards-traceability. It shall be made sure that the lowest calibration weight has no greater than ten times the mass of an unused PM-sample medium. The calibration report shall also state the density of the weights.

Annex A.1

TEST CYCLES

A.1.1. Steady-state discrete-mode testing

- (a) For variable-speed engines, the following 8-mode cycle 5/ shall be followed in dynamometer operation on the test engine:

Mode Number	Engine Speed	Torque [per cent]	Weighting Factor
1	Rated	100	0.15
2	Rated	75	0.15
3	Rated	50	0.15
4	Rated	10	0.10
5	Intermediate	100	0.10
6	Intermediate	75	0.10
7	Intermediate	50	0.10
8	Idle	---	0.15

- (b) For constant-speed engines, the following 5-mode cycle 6/ shall be followed in dynamometer operation on the test engine:

Mode Number	Engine Speed	Torque [per cent]	Weighting Factor
1	Rated	100	0.05
2	Rated	75	0.25
3	Rated	50	0.30
4	Rated	25	0.30
5	Rated	10	0.10

The load figures are percentage values of the torque corresponding to the prime power 7/ rating defined as the maximum power available during a variable power sequence, which may be run for an unlimited number of hours per year, between stated maintenance intervals and under the stated ambient conditions, the maintenance being carried out as prescribed by the manufacturer.

---

5/ Identical to C1 cycle as described in paragraph 8.3. of the ISO 8178-4 : 2007 standard.  
6/ Identical to D2 cycle as described in paragraph 8.4. of the ISO 8178-4 : 2007 standard.  
7/ For a better illustration of the prime power definition, see figure 2 of ISO 8528-1:1993(E) standard.

A.1.2. Steady-state ramped-modal testing

(a) For variable-speed engines, the following 9-mode duty cycle applies in case of ramped-modal testing:

RMC mode	Time in mode [s]	Engine speed <sup>(a) (c)</sup>	Torque (per cent) <sup>(b) (c)</sup>
1a Steady-state	126	Warm idle	0
1b Transition	20	Linear transition <sup>(2)</sup>	Linear transition
2a Steady-state	159	Intermediate	100
2b Transition	20	Intermediate	Linear transition
3a Steady-state	160	Intermediate	50
3b Transition	20	Intermediate	Linear transition
4a Steady-state	162	Intermediate	75
4b Transition	20	Linear transition	Linear transition
5a Steady-state	246	Rated	100
5b Transition	20	Rated	Linear transition
6a Steady-state	164	Rated	10
6b Transition	20	Rated	Linear transition
7a Steady-state	248	Rated	75
7b Transition	20	Rated	Linear transition
8a Steady-state	247	Rated	50
8b Transition	20	Linear transition	Linear transition
9 Steady-state	128	Warm idle	0

(a) Speed terms as per footnote of the steady-state discrete mode test.  
(b) The percent torque is relative to the maximum torque at the commanded engine speed.  
(c) Advance from one mode to the next within a 20-second transition phase. During the transition phase, command a linear progression from the torque setting of the current mode to the torque setting of the next mode, and simultaneously command a similar linear progression for engine speed if there is a change in speed setting

(b) For constant-speed engines, the following 5-mode duty cycle applies in case of ramped-modal testing:

RMC mode	Time in mode [s]	Engine speed	Torque (per cent) <sup>(a) (b)</sup>
1a Steady-state	53	Engine governed	100
1b Transition	20	Engine governed	Linear transition
2a Steady-state	101	Engine governed	10
2b Transition	20	Engine governed	Linear transition
3a Steady-state	277	Engine governed	75
3b Transition	20	Engine governed	Linear transition
4a Steady-state	339	Engine governed	25
4b Transition	20	Engine governed	Linear transition
5 Steady-state	350	Engine governed	50

(a) The percent torque is relative to maximum test torque.  
(b) Advance from one mode to the next within a 20-second transition phase. During the transition phase, command a linear progression from the torque setting of the current mode to the torque setting of the next mode.

A.1.3. Transient cycle

- (a) For variable-speed engines, the following full transient (variable speed and variable load) engine dynamometer schedule applies:



Time	Norm. Speed %	Norm. Torque %	Time	Norm. Speed %	Norm. Torque %	Time	Norm. Speed %	Norm. Torque %
1	0	0	52	102	46	103	74	24
2	0	0	53	102	41	104	77	6
3	0	0	54	102	31	105	76	12
4	0	0	55	89	2	106	74	39
5	0	0	56	82	0	107	72	30
6	0	0	57	47	1	108	75	22
7	0	0	58	23	1	109	78	64
8	0	0	59	1	3	110	102	34
9	0	0	60	1	8	111	103	28
10	0	0	61	1	3	112	103	28
11	0	0	62	1	5	113	103	19
12	0	0	63	1	6	114	103	32
13	0	0	64	1	4	115	104	25
14	0	0	65	1	4	116	103	38
15	0	0	66	0	6	117	103	39
16	0	0	67	1	4	118	103	34
17	0	0	68	9	21	119	102	44
18	0	0	69	25	56	120	103	38
19	0	0	70	64	26	121	102	43
20	0	0	71	60	31	122	103	34
21	0	0	72	63	20	123	102	41
22	0	0	73	62	24	124	103	44
23	0	0	74	64	8	125	103	37
24	1	3	75	58	44	126	103	27
25	1	3	76	65	10	127	104	13
26	1	3	77	65	12	128	104	30
27	1	3	78	68	23	129	104	19
28	1	3	79	69	30	130	103	28
29	1	3	80	71	30	131	104	40
30	1	6	81	74	15	132	104	32
31	1	6	82	71	23	133	101	63
32	2	1	83	73	20	134	102	54
33	4	13	84	73	21	135	102	52
34	7	18	85	73	19	136	102	51
35	9	21	86	70	33	137	103	40
36	17	20	87	70	34	138	104	34
37	33	42	88	65	47	139	102	36
38	57	46	89	66	47	140	104	44
39	44	33	90	64	53	141	103	44
40	31	0	91	65	45	142	104	33
41	22	27	92	66	38	143	102	27
42	33	43	93	67	49	144	103	26
43	80	49	94	69	39	145	79	53
44	105	47	95	69	39	146	51	37
45	98	70	96	66	42	147	24	23
46	104	36	97	71	29	148	13	33
47	104	65	98	75	29	149	19	55
48	96	71	99	72	23	150	45	30
49	101	62	100	74	22	151	34	7
50	102	51	101	75	24	152	14	4
51	102	50	102	73	30	153	8	16

Time	Norm.	Norm.	Time	Norm.	Norm.	Time	Norm.	Norm.
s	Speed	Torque	s	Speed	Torque	s	Speed	Torque
	%	%		%	%		%	%
154	15	6	205	20	18	256	102	84
155	39	47	206	27	34	257	58	66
156	39	4	207	32	33	258	64	97
157	35	26	208	41	31	259	56	80
158	27	38	209	43	31	260	51	67
159	43	40	210	37	33	261	52	96
160	14	23	211	26	18	262	63	62
161	10	10	212	18	29	263	71	6
162	15	33	213	14	51	264	33	16
163	35	72	214	13	11	265	47	45
164	60	39	215	12	9	266	43	56
165	55	31	216	15	33	267	42	27
166	47	30	217	20	25	268	42	64
167	16	7	218	25	17	269	75	74
168	0	6	219	31	29	270	68	96
169	0	8	220	36	66	271	86	61
170	0	8	221	66	40	272	66	0
171	0	2	222	50	13	273	37	0
172	2	17	223	16	24	274	45	37
173	10	28	224	26	50	275	68	96
174	28	31	225	64	23	276	80	97
175	33	30	226	81	20	277	92	96
176	36	0	227	83	11	278	90	97
177	19	10	228	79	23	279	82	96
178	1	18	229	76	31	280	94	81
179	0	16	230	68	24	281	90	85
180	1	3	231	59	33	282	96	65
181	1	4	232	59	3	283	70	96
182	1	5	233	25	7	284	55	95
183	1	6	234	21	10	285	70	96
184	1	5	235	20	19	286	79	96
185	1	3	236	4	10	287	81	71
186	1	4	237	5	7	288	71	60
187	1	4	238	4	5	289	92	65
188	1	6	239	4	6	290	82	63
189	8	18	240	4	6	291	61	47
190	20	51	241	4	5	292	52	37
191	49	19	242	7	5	293	24	0
192	41	13	243	16	28	294	20	7
193	31	16	244	28	25	295	39	48
194	28	21	245	52	53	296	39	54
195	21	17	246	50	8	297	63	58
196	31	21	247	26	40	298	53	31
197	21	8	248	48	29	299	51	24
198	0	14	249	54	39	300	48	40
199	0	12	250	60	42	301	39	0
200	3	8	251	48	18	302	35	18
201	3	22	252	54	51	303	36	16
202	12	20	253	88	90	304	29	17
203	14	20	254	103	84	305	28	21
204	16	17	255	103	85	306	31	15

Time	Norm.	Norm.	Time	Norm.	Norm.	Time	Norm.	Norm.
s	Speed	Torque	s	Speed	Torque	s	Speed	Torque
	%	%		%	%		%	%
307	31	10	358	29	0	409	34	43
308	43	19	359	18	13	410	68	83
309	49	63	360	25	11	411	102	48
310	78	61	361	28	24	412	62	0
311	78	46	362	34	53	413	41	39
312	66	65	363	65	83	414	71	86
313	78	97	364	80	44	415	91	52
314	84	63	365	77	46	416	89	55
315	57	26	366	76	50	417	89	56
316	36	22	367	45	52	418	88	58
317	20	34	368	61	98	419	78	69
318	19	8	369	61	69	420	98	39
319	9	10	370	63	49	421	64	61
320	5	5	371	32	0	422	90	34
321	7	11	372	10	8	423	88	38
322	15	15	373	17	7	424	97	62
323	12	9	374	16	13	425	100	53
324	13	27	375	11	6	426	81	58
325	15	28	376	9	5	427	74	51
326	16	28	377	9	12	428	76	57
327	16	31	378	12	46	429	76	72
328	15	20	379	15	30	430	85	72
329	17	0	380	26	28	431	84	60
330	20	34	381	13	9	432	83	72
331	21	25	382	16	21	433	83	72
332	20	0	383	24	4	434	86	72
333	23	25	384	36	43	435	89	72
334	30	58	385	65	85	436	86	72
335	63	96	386	78	66	437	87	72
336	83	60	387	63	39	438	88	72
337	61	0	388	32	34	439	88	71
338	26	0	389	46	55	440	87	72
339	29	44	390	47	42	441	85	71
340	68	97	391	42	39	442	88	72
341	80	97	392	27	0	443	88	72
342	88	97	393	14	5	444	84	72
343	99	88	394	14	14	445	83	73
344	102	86	395	24	54	446	77	73
345	100	82	396	60	90	447	74	73
346	74	79	397	53	66	448	76	72
347	57	79	398	70	48	449	46	77
348	76	97	399	77	93	450	78	62
349	84	97	400	79	67	451	79	35
350	86	97	401	46	65	452	82	38
351	81	98	402	69	98	453	81	41
352	83	83	403	80	97	454	79	37
353	65	96	404	74	97	455	78	35
354	93	72	405	75	98	456	78	38
355	63	60	406	56	61	457	78	46
356	72	49	407	42	0	458	75	49
357	56	27	408	36	32	459	73	50

Time	Norm.	Norm.	Time	Norm.	Norm.	Time	Norm.	Norm.
s	Speed	Torque	s	Speed	Torque	s	Speed	Torque
	%	%		%	%		%	%
460	79	58	511	85	73	562	43	25
461	79	71	512	84	73	563	30	60
462	83	44	513	85	73	564	40	45
463	53	48	514	86	73	565	37	32
464	40	48	515	85	73	566	37	32
465	51	75	516	85	73	567	43	70
466	75	72	517	85	72	568	70	54
467	89	67	518	85	73	569	77	47
468	93	60	519	83	73	570	79	66
469	89	73	520	79	73	571	85	53
470	86	73	521	78	73	572	83	57
471	81	73	522	81	73	573	86	52
472	78	73	523	82	72	574	85	51
473	78	73	524	94	56	575	70	39
474	76	73	525	66	48	576	50	5
475	79	73	526	35	71	577	38	36
476	82	73	527	51	44	578	30	71
477	86	73	528	60	23	579	75	53
478	88	72	529	64	10	580	84	40
479	92	71	530	63	14	581	85	42
480	97	54	531	70	37	582	86	49
481	73	43	532	76	45	583	86	57
482	36	64	533	78	18	584	89	68
483	63	31	534	76	51	585	99	61
484	78	1	535	75	33	586	77	29
485	69	27	536	81	17	587	81	72
486	67	28	537	76	45	588	89	69
487	72	9	538	76	30	589	49	56
488	71	9	539	80	14	590	79	70
489	78	36	540	71	18	591	104	59
490	81	56	541	71	14	592	103	54
491	75	53	542	71	11	593	102	56
492	60	45	543	65	2	594	102	56
493	50	37	544	31	26	595	103	61
494	66	41	545	24	72	596	102	64
495	51	61	546	64	70	597	103	60
496	68	47	547	77	62	598	93	72
497	29	42	548	80	68	599	86	73
498	24	73	549	83	53	600	76	73
499	64	71	550	83	50	601	59	49
500	90	71	551	83	50	602	46	22
501	100	61	552	85	43	603	40	65
502	94	73	553	86	45	604	72	31
503	84	73	554	89	35	605	72	27
504	79	73	555	82	61	606	67	44
505	75	72	556	87	50	607	68	37
506	78	73	557	85	55	608	67	42
507	80	73	558	89	49	609	68	50
508	81	73	559	87	70	610	77	43
509	81	73	560	91	39	611	58	4
510	83	73	561	72	3	612	22	37

Time	Norm.	Norm.	Time	Norm.	Norm.	Time	Norm.	Norm.
s	Speed	Torque	s	Speed	Torque	s	Speed	Torque
	%	%		%	%		%	%
613	57	69	664	92	72	715	102	64
614	68	38	665	91	72	716	102	69
615	73	2	666	90	71	717	102	68
616	40	14	667	90	71	718	102	70
617	42	38	668	91	71	719	102	69
618	64	69	669	90	70	720	102	70
619	64	74	670	90	72	721	102	70
620	67	73	671	91	71	722	102	62
621	65	73	672	90	71	723	104	38
622	68	73	673	90	71	724	104	15
623	65	49	674	92	72	725	102	24
624	81	0	675	93	69	726	102	45
625	37	25	676	90	70	727	102	47
626	24	69	677	93	72	728	104	40
627	68	71	678	91	70	729	101	52
628	70	71	679	89	71	730	103	32
629	76	70	680	91	71	731	102	50
630	71	72	681	90	71	732	103	30
631	73	69	682	90	71	733	103	44
632	76	70	683	92	71	734	102	40
633	77	72	684	91	71	735	103	43
634	77	72	685	93	71	736	103	41
635	77	72	686	93	68	737	102	46
636	77	70	687	98	68	738	103	39
637	76	71	688	98	67	739	102	41
638	76	71	689	100	69	740	103	41
639	77	71	690	99	68	741	102	38
640	77	71	691	100	71	742	103	39
641	78	70	692	99	68	743	102	46
642	77	70	693	100	69	744	104	46
643	77	71	694	102	72	745	103	49
644	79	72	695	101	69	746	102	45
645	78	70	696	100	69	747	103	42
646	80	70	697	102	71	748	103	46
647	82	71	698	102	71	749	103	38
648	84	71	699	102	69	750	102	48
649	83	71	700	102	71	751	103	35
650	83	73	701	102	68	752	102	48
651	81	70	702	100	69	753	103	49
652	80	71	703	102	70	754	102	48
653	78	71	704	102	68	755	102	46
654	76	70	705	102	70	756	103	47
655	76	70	706	102	72	757	102	49
656	76	71	707	102	68	758	102	42
657	79	71	708	102	69	759	102	52
658	78	71	709	100	68	760	102	57
659	81	70	710	102	71	761	102	55
660	83	72	711	101	64	762	102	61
661	84	71	712	102	69	763	102	61
662	86	71	713	102	69	764	102	58
663	87	71	714	101	69	765	103	58

Time	Norm.	Norm.	Time	Norm.	Norm.	Time	Norm.	Norm.
s	Speed	Torque	s	Speed	Torque	s	Speed	Torque
	%	%		%	%		%	%
766	102	59	817	81	46	868	83	16
767	102	54	818	80	39	869	83	12
768	102	63	819	80	32	870	83	9
769	102	61	820	81	28	871	83	8
770	103	55	821	80	26	872	83	7
771	102	60	822	80	23	873	83	6
772	102	72	823	80	23	874	83	6
773	103	56	824	80	20	875	83	6
774	102	55	825	81	19	876	83	6
775	102	67	826	80	18	877	83	6
776	103	56	827	81	17	878	59	4
777	84	42	828	80	20	879	50	5
778	48	7	829	81	24	880	51	5
779	48	6	830	81	21	881	51	5
780	48	6	831	80	26	882	51	5
781	48	7	832	80	24	883	50	5
782	48	6	833	80	23	884	50	5
783	48	7	834	80	22	885	50	5
784	67	21	835	81	21	886	50	5
785	105	59	836	81	24	887	50	5
786	105	96	837	81	24	888	51	5
787	105	74	838	81	22	889	51	5
788	105	66	839	81	22	890	51	5
789	105	62	840	81	21	891	63	50
790	105	66	841	81	31	892	81	34
791	89	41	842	81	27	893	81	25
792	52	5	843	80	26	894	81	29
793	48	5	844	80	26	895	81	23
794	48	7	845	81	25	896	80	24
795	48	5	846	80	21	897	81	24
796	48	6	847	81	20	898	81	28
797	48	4	848	83	21	899	81	27
798	52	6	849	83	15	900	81	22
799	51	5	850	83	12	901	81	19
800	51	6	851	83	9	902	81	17
801	51	6	852	83	8	903	81	17
802	52	5	853	83	7	904	81	17
803	52	5	854	83	6	905	81	15
804	57	44	855	83	6	906	80	15
805	98	90	856	83	6	907	80	28
806	105	94	857	83	6	908	81	22
807	105	100	858	83	6	909	81	24
808	105	98	859	76	5	910	81	19
809	105	95	860	49	8	911	81	21
810	105	96	861	51	7	912	81	20
811	105	92	862	51	20	913	83	26
812	104	97	863	78	52	914	80	63
813	100	85	864	80	38	915	80	59
814	94	74	865	81	33	916	83	100
815	87	62	866	83	29	917	81	73
816	81	50	867	83	22	918	83	53

Time	Norm.	Norm.	Time	Norm.	Norm.	Time	Norm.	Norm.
s	Speed	Torque	s	Speed	Torque	s	Speed	Torque
	%	%		%	%		%	%
919	80	76	970	81	39	1021	82	35
920	81	61	971	81	38	1022	79	53
921	80	50	972	80	41	1023	82	30
922	81	37	973	81	30	1024	83	29
923	82	49	974	81	23	1025	83	32
924	83	37	975	81	19	1026	83	28
925	83	25	976	81	25	1027	76	60
926	83	17	977	81	29	1028	79	51
927	83	13	978	83	47	1029	86	26
928	83	10	979	81	90	1030	82	34
929	83	8	980	81	75	1031	84	25
930	83	7	981	80	60	1032	86	23
931	83	7	982	81	48	1033	85	22
932	83	6	983	81	41	1034	83	26
933	83	6	984	81	30	1035	83	25
934	83	6	985	80	24	1036	83	37
935	71	5	986	81	20	1037	84	14
936	49	24	987	81	21	1038	83	39
937	69	64	988	81	29	1039	76	70
938	81	50	989	81	29	1040	78	81
939	81	43	990	81	27	1041	75	71
940	81	42	991	81	23	1042	86	47
941	81	31	992	81	25	1043	83	35
942	81	30	993	81	26	1044	81	43
943	81	35	994	81	22	1045	81	41
944	81	28	995	81	20	1046	79	46
945	81	27	996	81	17	1047	80	44
946	80	27	997	81	23	1048	84	20
947	81	31	998	83	65	1049	79	31
948	81	41	999	81	54	1050	87	29
949	81	41	1000	81	50	1051	82	49
950	81	37	1001	81	41	1052	84	21
951	81	43	1002	81	35	1053	82	56
952	81	34	1003	81	37	1054	81	30
953	81	31	1004	81	29	1055	85	21
954	81	26	1005	81	28	1056	86	16
955	81	23	1006	81	24	1057	79	52
956	81	27	1007	81	19	1058	78	60
957	81	38	1008	81	16	1059	74	55
958	81	40	1009	80	16	1060	78	84
959	81	39	1010	83	23	1061	80	54
960	81	27	1011	83	17	1062	80	35
961	81	33	1012	83	13	1063	82	24
962	80	28	1013	83	27	1064	83	43
963	81	34	1014	81	58	1065	79	49
964	83	72	1015	81	60	1066	83	50
965	81	49	1016	81	46	1067	86	12
966	81	51	1017	80	41	1068	64	14
967	80	55	1018	80	36	1069	24	14
968	81	48	1019	81	26	1070	49	21
969	81	36	1020	86	18	1071	77	48

Time	Norm.	Norm.	Time	Norm.	Norm.	Time	Norm.	Norm.
s	Speed	Torque	s	Speed	Torque	s	Speed	Torque
	%	%		%	%		%	%
1072	103	11	1123	66	62	1174	76	8
1073	98	48	1124	74	29	1175	76	7
1074	101	34	1125	64	74	1176	67	45
1075	99	39	1126	69	40	1177	75	13
1076	103	11	1127	76	2	1178	75	12
1077	103	19	1128	72	29	1179	73	21
1078	103	7	1129	66	65	1180	68	46
1079	103	13	1130	54	69	1181	74	8
1080	103	10	1131	69	56	1182	76	11
1081	102	13	1132	69	40	1183	76	14
1082	101	29	1133	73	54	1184	74	11
1083	102	25	1134	63	92	1185	74	18
1084	102	20	1135	61	67	1186	73	22
1085	96	60	1136	72	42	1187	74	20
1086	99	38	1137	78	2	1188	74	19
1087	102	24	1138	76	34	1189	70	22
1088	100	31	1139	67	80	1190	71	23
1089	100	28	1140	70	67	1191	73	19
1090	98	3	1141	53	70	1192	73	19
1091	102	26	1142	72	65	1193	72	20
1092	95	64	1143	60	57	1194	64	60
1093	102	23	1144	74	29	1195	70	39
1094	102	25	1145	69	31	1196	66	56
1095	98	42	1146	76	1	1197	68	64
1096	93	68	1147	74	22	1198	30	68
1097	101	25	1148	72	52	1199	70	38
1098	95	64	1149	62	96	1200	66	47
1099	101	35	1150	54	72	1201	76	14
1100	94	59	1151	72	28	1202	74	18
1101	97	37	1152	72	35	1203	69	46
1102	97	60	1153	64	68	1204	68	62
1103	93	98	1154	74	27	1205	68	62
1104	98	53	1155	76	14	1206	68	62
1105	103	13	1156	69	38	1207	68	62
1106	103	11	1157	66	59	1208	68	62
1107	103	11	1158	64	99	1209	68	62
1108	103	13	1159	51	86	1210	54	50
1109	103	10	1160	70	53	1211	41	37
1110	103	10	1161	72	36	1212	27	25
1111	103	11	1162	71	47	1213	14	12
1112	103	10	1163	70	42	1214	0	0
1113	103	10	1164	67	34	1215	0	0
1114	102	18	1165	74	2	1216	0	0
1115	102	31	1166	75	21	1217	0	0
1116	101	24	1167	74	15	1218	0	0
1117	102	19	1168	75	13	1219	0	0
1118	103	10	1169	76	10	1220	0	0
1119	102	12	1170	75	13	1221	0	0
1120	99	56	1171	75	10	1222	0	0
1121	96	59	1172	75	7	1223	0	0
1122	74	28	1173	75	13	1224	0	0



Time	Norm.	Norm.
s	Speed	Torque
	%	%
1225	0	0
1226	0	0
1227	0	0
1228	0	0
1229	0	0
1230	0	0
1231	0	0
1232	0	0
1233	0	0
1234	0	0
1235	0	0
1236	0	0
1237	0	0
1238	0	0

Time	Norm.	Norm.
s	Speed	Torque
	%	%

Time	Norm.	Norm.
s	Speed	Torque
	%	%

Annex A.2

STATISTICS

A.2.1. Arithmetic mean

The arithmetic mean,  $\bar{y}$ , shall be calculated as follows:

$$\bar{y} = \frac{\sum_{i=1}^{10} y_i}{N} \quad (\text{A.2-1})$$

A.2.2. Standard deviation

The standard deviation for a non-biased (e.g.,  $N-1$ ) sample,  $\sigma$ , shall be calculated as follows:

$$\sigma_y = \sqrt{\frac{\sum_{i=1}^N (y_i - \bar{y})^2}{(N-1)}} \quad (\text{A.2-2})$$

A.2.3. Root mean square

The root mean square,  $rms_y$ , shall be calculated as follows:

$$rms_y = \sqrt{\frac{1}{N} \sum_{i=1}^N y_i^2} \quad (\text{A.2-3})$$

A.2.4. t-test

It shall be determined if the data passes a t-test by using the following equations and tables:

- (a) For an unpaired t-test, the t statistic and its number of degrees of freedom,  $\nu$ , shall be calculated as follows:

$$t = \frac{|\bar{y}_{\text{ref}} - \bar{y}|}{\sqrt{\frac{\sigma_{\text{ref}}^2}{N_{\text{ref}}} + \frac{\sigma_y^2}{N}}} \quad (\text{A.2-4})$$

$$\nu = \frac{\left(\frac{\sigma_{\text{ref}}^2}{N_{\text{ref}}} + \frac{\sigma_y^2}{N}\right)^2}{\frac{(\sigma_{\text{ref}}^2/N_{\text{ref}})^2}{N_{\text{ref}} - 1} + \frac{(\sigma_y^2/N)^2}{N - 1}} \quad (\text{A.2-5})$$

- (b) For a paired  $t$ -test, the  $t$  statistic and its number of degrees of freedom,  $\nu$ , shall be calculated as follows, noting that the  $\sigma_i$  are the errors (*e.g.*, differences) between each pair of  $y_{refi}$  and  $y_i$ :

$$t = \frac{|\bar{\varepsilon}| \cdot \sqrt{N}}{\sigma_\varepsilon} \quad \nu = N - 1 \quad (\text{A.2-6})$$

- (c) Table A.2.1 of this paragraph shall be used to compare  $t$  to the  $t_{crit}$  values tabulated versus the number of degrees of freedom. If  $t$  is less than  $t_{crit}$ , then  $t$  passes the  $t$ -test.

$\nu$	Confidence	
	90 per cent	95 per cent
1	6.314	12.706
2	2.920	4.303
3	2.353	3.182
4	2.132	2.776
5	2.015	2.571
6	1.943	2.447
7	1.895	2.365
8	1.860	2.306
9	1.833	2.262
10	1.812	2.228
11	1.796	2.201
12	1.782	2.179
13	1.771	2.160
14	1.761	2.145
15	1.753	2.131
16	1.746	2.120
18	1.734	2.101
20	1.725	2.086
22	1.717	2.074
24	1.711	2.064
26	1.706	2.056
28	1.701	2.048
30	1.697	2.042
35	1.690	2.030
40	1.684	2.021
50	1.676	2.009
70	1.667	1.994
100	1.660	1.984
1000+	1.645	1.960

Table A.2.1: Critical  $t$  values versus number of degrees of freedom,  $\nu$

Linear interpolation shall be used to establish values not shown here.

A.2.5. F-test

The  $F$  statistic shall be calculated as follows:

$$F_y = \frac{\sigma_y^2}{\sigma_{\text{ref}}^2} \quad (\text{A.2-7})$$

- (a) For a 90 per cent confidence  $F$ -test, Table 2 of this paragraph is used to compare  $F$  to the  $F_{\text{crit}90}$  values tabulated versus  $(N-1)$  and  $(N_{\text{ref}}-1)$ . If  $F$  is less than  $F_{\text{crit}90}$ , then  $F$  passes the  $F$ -test at 90 per cent confidence.
- (b) For a 95 per cent confidence  $F$ -test, Table 3 of this paragraph is used to compare  $F$  to the  $F_{\text{crit}95}$  values tabulated versus  $(N-1)$  and  $(N_{\text{ref}}-1)$ . If  $F$  is less than  $F_{\text{crit}95}$ , then  $F$  passes the  $F$ -test at 95 per cent confidence.

$N-1$	1	2	3	4	5	6	7	8	9	10	12	15	20	24	30	40	60	120	1000+
$N_{ref}-1$																			
1	39.86	49.50	53.59	55.83	57.24	58.20	58.90	59.43	59.85	60.19	60.70	61.22	61.74	62.00	62.26	62.52	62.79	63.06	63.32
2	8.526	9.000	9.162	9.243	9.293	9.326	9.349	9.367	9.381	9.392	9.408	9.425	9.441	9.450	9.458	9.466	9.475	9.483	9.491
3	5.538	5.462	5.391	5.343	5.309	5.285	5.266	5.252	5.240	5.230	5.216	5.200	5.184	5.176	5.168	5.160	5.151	5.143	5.134
4	4.545	4.325	4.191	4.107	4.051	4.010	3.979	3.955	3.936	3.920	3.896	3.870	3.844	3.831	3.817	3.804	3.790	3.775	3.761
5	4.060	3.780	3.619	3.520	3.453	3.405	3.368	3.339	3.316	3.297	3.268	3.238	3.207	3.191	3.174	3.157	3.140	3.123	3.105
6	3.776	3.463	3.289	3.181	3.108	3.055	3.014	2.983	2.958	2.937	2.905	2.871	2.836	2.818	2.800	2.781	2.762	2.742	2.722
7	3.589	3.257	3.074	2.961	2.883	2.827	2.785	2.752	2.725	2.703	2.668	2.632	2.595	2.575	2.555	2.535	2.514	2.493	2.471
8	3.458	3.113	2.924	2.806	2.726	2.668	2.624	2.589	2.561	2.538	2.502	2.464	2.425	2.404	2.383	2.361	2.339	2.316	2.293
9	3.360	3.006	2.813	2.693	2.611	2.551	2.505	2.469	2.440	2.416	2.379	2.340	2.298	2.277	2.255	2.232	2.208	2.184	2.159
10	3.285	2.924	2.728	2.605	2.522	2.461	2.414	2.377	2.347	2.323	2.284	2.244	2.201	2.178	2.155	2.132	2.107	2.082	2.055
11	3.225	2.860	2.660	2.536	2.451	2.389	2.342	2.304	2.274	2.248	2.209	2.167	2.123	2.100	2.076	2.052	2.026	2.000	1.972
12	3.177	2.807	2.606	2.480	2.394	2.331	2.283	2.245	2.214	2.188	2.147	2.105	2.060	2.036	2.011	1.986	1.960	1.932	1.904
13	3.136	2.763	2.560	2.434	2.347	2.283	2.234	2.195	2.164	2.138	2.097	2.053	2.007	1.983	1.958	1.931	1.904	1.876	1.846
14	3.102	2.726	2.522	2.395	2.307	2.243	2.193	2.154	2.122	2.095	2.054	2.010	1.962	1.938	1.912	1.885	1.857	1.828	1.797
15	3.073	2.695	2.490	2.361	2.273	2.208	2.158	2.119	2.086	2.059	2.017	1.972	1.924	1.899	1.873	1.845	1.817	1.787	1.755
16	3.048	2.668	2.462	2.333	2.244	2.178	2.128	2.088	2.055	2.028	1.985	1.940	1.891	1.866	1.839	1.811	1.782	1.751	1.718
17	3.026	2.645	2.437	2.308	2.218	2.152	2.102	2.061	2.028	2.001	1.958	1.912	1.862	1.836	1.809	1.781	1.751	1.719	1.686
18	3.007	2.624	2.416	2.286	2.196	2.130	2.079	2.038	2.005	1.977	1.933	1.887	1.837	1.810	1.783	1.754	1.723	1.691	1.657
19	2.990	2.606	2.397	2.266	2.176	2.109	2.058	2.017	1.984	1.956	1.912	1.865	1.814	1.787	1.759	1.730	1.699	1.666	1.631
20	2.975	2.589	2.380	2.249	2.158	2.091	2.040	1.999	1.965	1.937	1.892	1.845	1.794	1.767	1.738	1.708	1.677	1.643	1.607
21	2.961	2.575	2.365	2.233	2.142	2.075	2.023	1.982	1.948	1.920	1.875	1.827	1.776	1.748	1.719	1.689	1.657	1.623	1.586
20	2.949	2.561	2.351	2.219	2.128	2.061	2.008	1.967	1.933	1.904	1.859	1.811	1.759	1.731	1.702	1.671	1.639	1.604	1.567
23	2.937	2.549	2.339	2.207	2.115	2.047	1.995	1.953	1.919	1.890	1.845	1.796	1.744	1.716	1.686	1.655	1.622	1.587	1.549
24	2.927	2.538	2.327	2.195	2.103	2.035	1.983	1.941	1.906	1.877	1.832	1.783	1.730	1.702	1.672	1.641	1.607	1.571	1.533

25	2.918	2.528	2.317	2.184	2.092	2.024	1.971	1.929	1.895	1.866	1.820	1.771	1.718	1.689	1.659	1.627	1.593	1.557	1.518
26	2.909	2.519	2.307	2.174	2.082	2.014	1.961	1.919	1.884	1.855	1.809	1.760	1.706	1.677	1.647	1.615	1.581	1.544	1.504
27	2.901	2.511	2.299	2.165	2.073	2.005	1.952	1.909	1.874	1.845	1.799	1.749	1.695	1.666	1.636	1.603	1.569	1.531	1.491
28	2.894	2.503	2.291	2.157	2.064	1.996	1.943	1.900	1.865	1.836	1.790	1.740	1.685	1.656	1.625	1.593	1.558	1.520	1.478
29	2.887	2.495	2.283	2.149	2.057	1.988	1.935	1.892	1.857	1.827	1.781	1.731	1.676	1.647	1.616	1.583	1.547	1.509	1.467
30	2.881	2.489	2.276	2.142	2.049	1.980	1.927	1.884	1.849	1.819	1.773	1.722	1.667	1.638	1.606	1.573	1.538	1.499	1.456
40	2.835	2.440	2.226	2.091	1.997	1.927	1.873	1.829	1.793	1.763	1.715	1.662	1.605	1.574	1.541	1.506	1.467	1.425	1.377
60	2.791	2.393	2.177	2.041	1.946	1.875	1.819	1.775	1.738	1.707	1.657	1.603	1.543	1.511	1.476	1.437	1.395	1.348	1.291
120	2.748	2.347	2.130	1.992	1.896	1.824	1.767	1.722	1.684	1.652	1.601	1.545	1.482	1.447	1.409	1.368	1.320	1.265	1.193
1000+	2.706	2.303	2.084	1.945	1.847	1.774	1.717	1.670	1.632	1.599	1.546	1.487	1.421	1.383	1.342	1.295	1.240	1.169	1.000

Table A.2.2 . – Critical  $F$  values,  $F_{\text{crit}90}$ , versus  $N-1$  and  $N_{\text{ref}}-1$  at 90 per cent confidence

<i>N</i> -1	1	2	3	4	5	6	7	8	9	10	12	15	20	24	30	40	60	120	1000+
<i>N<sub>ref</sub></i> -1																			
1	161.4	199.5	215.7	224.5	230.1	233.9	236.7	238.8	240.5	241.8	243.9	245.9	248.0	249.0	250.1	251.1	252.2	253.2	254.3
2	18.51	19.00	19.16	19.24	19.29	19.33	19.35	19.37	19.38	19.39	19.41	19.42	19.44	19.45	19.46	19.47	19.47	19.48	19.49
3	10.12	9.552	9.277	9.117	9.014	8.941	8.887	8.845	8.812	8.786	8.745	8.703	8.660	8.639	8.617	8.594	8.572	8.549	8.526
4	7.709	6.944	6.591	6.388	6.256	6.163	6.094	6.041	5.999	5.964	5.912	5.858	5.803	5.774	5.746	5.717	5.688	5.658	5.628
5	6.608	5.786	5.410	5.192	5.050	4.950	4.876	4.818	4.773	4.735	4.678	4.619	4.558	4.527	4.496	4.464	4.431	4.399	4.365
6	5.987	5.143	4.757	4.534	4.387	4.284	4.207	4.147	4.099	4.060	4.000	3.938	3.874	3.842	3.808	3.774	3.740	3.705	3.669
7	5.591	4.737	4.347	4.120	3.972	3.866	3.787	3.726	3.677	3.637	3.575	3.511	3.445	3.411	3.376	3.340	3.304	3.267	3.230
8	5.318	4.459	4.066	3.838	3.688	3.581	3.501	3.438	3.388	3.347	3.284	3.218	3.150	3.115	3.079	3.043	3.005	2.967	2.928
9	5.117	4.257	3.863	3.633	3.482	3.374	3.293	3.230	3.179	3.137	3.073	3.006	2.937	2.901	2.864	2.826	2.787	2.748	2.707
10	4.965	4.103	3.708	3.478	3.326	3.217	3.136	3.072	3.020	2.978	2.913	2.845	2.774	2.737	2.700	2.661	2.621	2.580	2.538
11	4.844	3.982	3.587	3.357	3.204	3.095	3.012	2.948	2.896	2.854	2.788	2.719	2.646	2.609	2.571	2.531	2.490	2.448	2.405
12	4.747	3.885	3.490	3.259	3.106	2.996	2.913	2.849	2.796	2.753	2.687	2.617	2.544	2.506	2.466	2.426	2.384	2.341	2.296
13	4.667	3.806	3.411	3.179	3.025	2.915	2.832	2.767	2.714	2.671	2.604	2.533	2.459	2.420	2.380	2.339	2.297	2.252	2.206
14	4.600	3.739	3.344	3.112	2.958	2.848	2.764	2.699	2.646	2.602	2.534	2.463	2.388	2.349	2.308	2.266	2.223	2.178	2.131
15	4.543	3.682	3.287	3.056	2.901	2.791	2.707	2.641	2.588	2.544	2.475	2.403	2.328	2.288	2.247	2.204	2.160	2.114	2.066
16	4.494	3.634	3.239	3.007	2.852	2.741	2.657	2.591	2.538	2.494	2.425	2.352	2.276	2.235	2.194	2.151	2.106	2.059	2.010
17	4.451	3.592	3.197	2.965	2.810	2.699	2.614	2.548	2.494	2.450	2.381	2.308	2.230	2.190	2.148	2.104	2.058	2.011	1.960
18	4.414	3.555	3.160	2.928	2.773	2.661	2.577	2.510	2.456	2.412	2.342	2.269	2.191	2.150	2.107	2.063	2.017	1.968	1.917
19	4.381	3.522	3.127	2.895	2.740	2.628	2.544	2.477	2.423	2.378	2.308	2.234	2.156	2.114	2.071	2.026	1.980	1.930	1.878
20	4.351	3.493	3.098	2.866	2.711	2.599	2.514	2.447	2.393	2.348	2.278	2.203	2.124	2.083	2.039	1.994	1.946	1.896	1.843
21	4.325	3.467	3.073	2.840	2.685	2.573	2.488	2.421	2.366	2.321	2.250	2.176	2.096	2.054	2.010	1.965	1.917	1.866	1.812
22	4.301	3.443	3.049	2.817	2.661	2.549	2.464	2.397	2.342	2.297	2.226	2.151	2.071	2.028	1.984	1.938	1.889	1.838	1.783
23	4.279	3.422	3.028	2.796	2.640	2.528	2.442	2.375	2.320	2.275	2.204	2.128	2.048	2.005	1.961	1.914	1.865	1.813	1.757
24	4.260	3.403	3.009	2.776	2.621	2.508	2.423	2.355	2.300	2.255	2.183	2.108	2.027	1.984	1.939	1.892	1.842	1.790	1.733
25	4.242	3.385	2.991	2.759	2.603	2.490	2.405	2.337	2.282	2.237	2.165	2.089	2.008	1.964	1.919	1.872	1.822	1.768	1.711

26	4.225	3.369	2.975	2.743	2.587	2.474	2.388	2.321	2.266	2.220	2.148	2.072	1.990	1.946	1.901	1.853	1.803	1.749	1.691
27	4.210	3.354	2.960	2.728	2.572	2.459	2.373	2.305	2.250	2.204	2.132	2.056	1.974	1.930	1.884	1.836	1.785	1.731	1.672
28	4.196	3.340	2.947	2.714	2.558	2.445	2.359	2.291	2.236	2.190	2.118	2.041	1.959	1.915	1.869	1.820	1.769	1.714	1.654
29	4.183	3.328	2.934	2.701	2.545	2.432	2.346	2.278	2.223	2.177	2.105	2.028	1.945	1.901	1.854	1.806	1.754	1.698	1.638
30	4.171	3.316	2.922	2.690	2.534	2.421	2.334	2.266	2.211	2.165	2.092	2.015	1.932	1.887	1.841	1.792	1.740	1.684	1.622
40	4.085	3.232	2.839	2.606	2.450	2.336	2.249	2.180	2.124	2.077	2.004	1.925	1.839	1.793	1.744	1.693	1.637	1.577	1.509
60	4.001	3.150	2.758	2.525	2.368	2.254	2.167	2.097	2.040	1.993	1.917	1.836	1.748	1.700	1.649	1.594	1.534	1.467	1.389
120	3.920	3.072	2.680	2.447	2.290	2.175	2.087	2.016	1.959	1.911	1.834	1.751	1.659	1.608	1.554	1.495	1.429	1.352	1.254
1000+	3.842	2.996	2.605	2.372	2.214	2.099	2.010	1.938	1.880	1.831	1.752	1.666	1.571	1.517	1.459	1.394	1.318	1.221	1.000

Table A.2.3 – Critical  $F$  values,  $F_{\text{crit}95}$ , versus  $N-1$  and  $N_{\text{ref}}-1$  at 95 per cent confidence



A.2.6. Slope

The least-squares regression slope,  $a_{1y}$ , shall be calculated as follows:

$$a_{1y} = \frac{\sum_{i=1}^N (y_i - \bar{y}) \cdot (y_{\text{ref}i} - \bar{y}_{\text{ref}})}{\sum_{i=1}^N (y_{\text{ref}i} - \bar{y}_{\text{ref}})^2} \quad (\text{A.2-8})$$

A.2.7. Intercept

The least-squares regression intercept,  $a_{0y}$ , shall be calculated as follows:

$$a_{0y} = \bar{y} - (a_{1y} \cdot \bar{y}_{\text{ref}}) \quad (\text{A.2-9})$$

A.2.8. Standard estimate of error

The standard estimate of error,  $SEE$ , shall be calculated as follows:

$$SEE_y = \frac{\sqrt{\sum_{i=1}^N [y_i - a_{0y} - (a_{1y} \cdot y_{\text{ref}i})]^2}}{N - 2} \quad (\text{A.2-10})$$

A.2.9. Coefficient of determination

The coefficient of determination,  $r^2$ , shall be calculated as follows:

$$r_y^2 = 1 - \frac{\sum_{i=1}^N [y_i - a_{0y} - (a_{1y} \cdot y_{\text{ref}i})]^2}{\sum_{i=1}^N [y_i - \bar{y}]^2} \quad (\text{A.2-11})$$

Annex A.3

1980 INTERNATIONAL GRAVITY FORMULA

The acceleration of Earth's gravity,  $a_g$ , varies depending on the location and  $a_g$  is calculated for a respective latitude, as follows:

$$a_g = 9.7803267715 \left[ 1 + 5.2790414 \times 10^{-3} \sin^2 \theta + 2.32718 \times 10^{-5} \sin^4 \theta + 1.262 \times 10^{-7} \sin^6 \theta + 7 \times 10^{-10} \sin^8 \theta \right] \quad (\text{A.3-1})$$

Where:

$\theta$  = Degrees north or south latitude

Annex A.4

CARBON FLOW CHECK

A.4.1. Introduction

All but a tiny part of the carbon in the exhaust comes from the fuel, and all but a minimal part of this is manifest in the exhaust gas as CO<sub>2</sub>. This is the basis for a system verification check based on CO<sub>2</sub> measurements.

The flow of carbon into the exhaust measurement systems is determined from the fuel flow rate. The flow of carbon at various sampling points in the emissions and particulate sampling systems is determined from the CO<sub>2</sub> concentrations and gas flow rates at those points.

In this sense, the engine provides a known source of carbon flow, and observing the same carbon flow in the exhaust pipe and at the outlet of the partial flow PM sampling system verifies leak integrity and flow measurement accuracy. This check has the advantage that the components are operating under actual engine test conditions of temperature and flow.

Figure A.4.1 shows the sampling points at which the carbon flows shall be checked. The specific equations for the carbon flows at each of the sample points are given below.

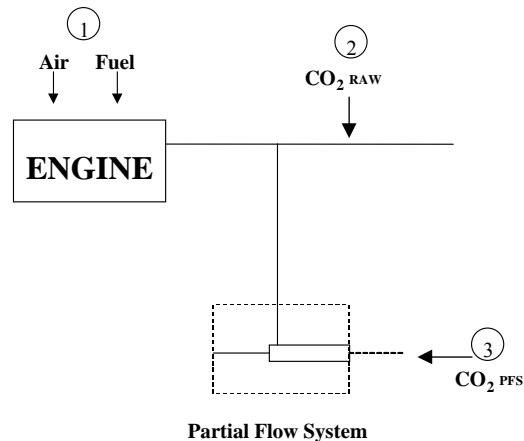

Figure A.4.1 – Measuring points for carbon flow check

A.4.2. Carbon flow rate into the engine (location 1)

The carbon mass flow rate into the engine  $q_{mCf}$  [kg/s] for a fuel  $CH_\alpha O_\varepsilon$  is given by:

$$q_{mCf} = \frac{12.011}{12.011 + \alpha + 15.9994 \cdot \varepsilon} \cdot q_{mf} \quad (\text{A.4-1})$$

Where:

$q_{mf}$  = fuel mass flow rate [kg/s]

A.4.3. Carbon flow rate in the raw exhaust (location 2)

The carbon mass flow rate in the exhaust pipe of the engine  $q_{mCe}$  [kg/s] shall be determined from the raw  $CO_2$  concentration and the exhaust gas mass flow rate:

$$q_{mCe} = \left( \frac{c_{CO_2,r} - c_{CO_2,a}}{100} \right) \cdot q_{mew} \cdot \frac{12.011}{M_e} \quad (\text{A.4-2})$$

Where:

$c_{CO_2,r}$  = wet  $CO_2$  concentration in the raw exhaust gas [per cent]

$c_{CO_2,a}$  = wet  $CO_2$  concentration in the ambient air [per cent]

$q_{mew}$  = exhaust gas mass flow rate on wet basis [kg/s]

$M_e$  = molar mass of exhaust gas [g/mol]

If  $CO_2$  is measured on a dry basis it shall be converted to a wet basis according to paragraph A.8.2.2.

A.4.4. Carbon flow rate in the dilution system (location 3)

For the partial flow dilution system, the splitting ratio also needs to be taken into account. The carbon flow rate in an equivalent dilution system  $q_{mCp}$  [kg/s] (with equivalent meaning equivalent to a full flow system where the total flow is diluted) shall be determined from the dilute  $CO_2$  concentration, the exhaust gas mass flow rate and the sample flow rate; the new equation is identical to equation A.4-2, being only supplemented by the dilution factor  $q_{mdew}/q_{mp}$ .

$$q_{mCp} = \left( \frac{c_{CO_2,d} - c_{CO_2,a}}{100} \right) \cdot q_{mew} \cdot \frac{12.011}{M_e} \cdot \frac{q_{mdew}}{q_{mp}} \quad (\text{A.4-3})$$

Where:

$c_{CO_2,d}$  = wet  $CO_2$  concentration in the dilute exhaust gas at the outlet of the dilution tunnel [per cent]

$c_{CO_2,a}$  = wet  $CO_2$  concentration in the ambient air [per cent]

$q_{mdew}$  = diluted sample flow in the partial flow dilution system [kg/s]

$q_{mew}$  = exhaust gas mass flow rate on wet basis [kg/s]  
 $q_{mp}$  = sample flow of exhaust gas into partial flow dilution system [kg/s]  
 $M_e$  = molar mass of exhaust gas [g/mol]

If CO<sub>2</sub> is measured on a dry basis, it shall be converted to wet basis according to paragraph A.8.2.2.

A.4.5. Calculation of the molar mass of the exhaust gas

The molar mass of the exhaust gas shall be calculated according to equation (A.8-15) (see paragraph A.8.2.4.1.)

Alternatively, the following exhaust gas molar masses may be used:

$M_e$  (diesel) = 28.9 g/mol

Annex A.5

## INSTALLATION REQUIREMENTS FOR EQUIPMENT AND AUXILIARIES

Number	Equipment and auxiliaries	Fitted for emission test
1	Inlet system Inlet manifold Crankcase emission control system Air flow meter Air filter Inlet silencer	Yes Yes Yes Yes <sup>(a)</sup> Yes <sup>(a)</sup>
2	Exhaust system	
	Exhaust aftertreatment Exhaust manifold Connecting pipes  Silencer Tail pipe Exhaust brake Pressure charging device	Yes Yes Yes <sup>(b)</sup>  Yes <sup>(b)</sup> Yes <sup>(b)</sup> No <sup>(c)</sup> Yes
3	Fuel supply pump	Yes <sup>(d)</sup>
4	Fuel injection equipment Prefilter Filter Pump	Yes Yes Yes
5	High-pressure pipe Injector Electronic control unit, sensors, etc. Governor/control system Automatic full-load stop for the control rack depending on atmospheric conditions	Yes Yes Yes Yes Yes
6	Liquid-cooling equipment Radiator Fan Fan cowl Water pump Thermostat	No No No Yes <sup>(e)</sup> Yes <sup>(f)</sup>
7	Air cooling Cowl Fan or Blower Temperature-regulating device	No <sup>(g)</sup> No <sup>(g)</sup> No
8	Pressure charging equipment Compressor driven either directly by the engine and/or by the exhaust gases Charge air cooler Coolant pump or fan (engine-driven) Coolant flow control device	Yes  Yes <sup>(g)(h)</sup> No <sup>(g)</sup> Yes
9	Auxiliary test-bed fan	Yes, if necessary
10	Anti-pollution device	Yes

Number	Equipment and auxiliaries	Fitted for emission test
11	Starting equipment	Yes or test bed equipment <sup>(1)</sup>
12	Lubricating oil pump	Yes
13	Certain auxiliaries whose definition is linked with the operation of the machine and which may be mounted on the engine shall be removed for the test. The following non-exhaustive list is given as an example: (i) air compressor for brakes (ii) power steering compressor (iii) suspension compressor (iv) air-conditioning system.	No
<p>(a) The complete inlet system shall be fitted as provided for the intended application:  (i) where there is a risk of an appreciable effect on the engine power;  (ii) when the manufacturer requests that this should be done.  In other cases, an equivalent system may be used and a check should be made to ascertain that the intake pressure does not differ by more than 100 Pa from the upper limit specified by the manufacturer for a clean air filter.</p> <p>(b) The complete exhaust system shall be fitted as provided for the intended application:  (i) where there is a risk of an appreciable effect on the engine power;  (ii) when the manufacturer requests that this should be done.  In other cases, an equivalent system may be installed provided the pressure measured does not differ by more than 1,000 Pa from the upper limit specified by the manufacturer.</p> <p>(c) If an exhaust brake is incorporated in the engine, the throttle valve shall be fixed in the fully open position.</p> <p>(d) The fuel feed pressure may be adjusted, if necessary, to reproduce the pressure existing in the particular engine application (particularly when a "fuel return" system is used).</p> <p>(e) The cooling-liquid circulation shall be operated by the engine water pump only. Cooling of the liquid may be produced by an external circuit, such that the pressure loss of this circuit and the pressure at the pump inlet remain substantially the same as those of the engine cooling system.</p> <p>(f) The thermostat may be fixed in the fully open position.</p> <p>(g) When the cooling fan or blower is fitted for the test, the power absorbed shall be added to the results, except for cooling fans of air cooled engines directly fitted on the crankshaft. The fan or blower power shall be determined at the speeds used for the test either by calculation from standard characteristics or by practical tests.</p> <p>(h) Charge air-cooled engines shall be tested with charge air cooling, whether liquid - or air-cooled, but if the manufacturer prefers, a test bench system may replace the air cooler. In either case, the measurement of power at each speed shall be made with the maximum pressure drop and the minimum temperature drop of the engine air across the charge air cooler on the test bench system as those specified by the manufacturer.</p> <p>(i) The power for electrical or other starting systems shall be provided from the test bed.</p>		

Annex A.6

## DIESEL REFERENCE FUELS

A.6.1. EUROPEAN UNION DIESEL REFERENCE FUEL

Parameter	Unit	Limits <sup>(a)</sup>		Test method	
		Minimum	Maximum		
Cetane number		52	54	ISO 5165	
Density at 15 °C	kg/m <sup>3</sup>	833	837	ISO 3675	
Distillation:					
- 50 per cent vol.	°C	245		ISO 3405	
- 95 per cent vol.	°C	345	350		
- final boiling point	°C		370		
Flash point	°C	55		ISO 2719	
Cold filter plugging point	°C		-5	EN 116	
Kinematic viscosity at 40 °C	mm <sup>2</sup> /s	2.3	3.3	ISO 3104	
Polycyclic aromatic hydrocarbons	per cent m/m	2.0	6.0	EN 12916	
Conradson carbon residue (10 per cent DR)	per cent m/m		0.2	ISO 10370	
Ash content	per cent m/m		0.01	EN-ISO 6245	
Water content	per cent m/m		0.02	EN-ISO 12937	
Sulphur content	mg/kg		10	EN-ISO 14596	
Copper corrosion at 50 °C			1	EN-ISO 2160	
Lubricity (HFRR at 60 °C)	µm		400	CEC F-06-A-96	
Neutralisation number	mg KOH/g		0.02		
Oxidation stability	mg/ml		0.025	EN-ISO 12205	
<p><sup>(a)</sup> The values quoted in the specification are "true values". In establishment of their limit values the terms of ISO 4259 "Petroleum products - Determination and application of precision data in relation to methods of test." have been applied and in fixing a minimum value, a minimum difference of 2R above zero has been taken into account; in fixing a maximum and minimum value, the minimum difference is 4R (R = reproducibility).</p> <p>Notwithstanding this measure, which is necessary for statistical reasons, the manufacturer of fuels should nevertheless aim at a zero value where the stipulated maximum value is 2R and at the mean value in the case of quotations of maximum and minimum limits. Should it be necessary to clarify the question as to whether a fuel meets the requirements of the specifications, the terms of ISO 4259 should be applied.</p>					



A.6.2. UNITED STATES OF AMERICA DIESEL REFERENCE FUEL 2-D

Parameter	Unit	Test method	Limits	
			min	max
Cetane number	1	ASTM D 613	40	50
Cetane index	1	ASTM D 976	40	50
Density at 15 °C	kg/m <sup>3</sup>	ASTM D 1298	840	865
Distillation		ASTM D 86		
Initial boiling point	°C		171	204
10 per cent Vol.	°C		204	238
50 per cent Vol.	°C		243	282
90 per cent Vol.	°C		293	332
Final boiling point	°C		321	366
Flash point	°C	ASTM D 93	54	-
Kinematic viscosity at 37.9 °C	mm <sup>2</sup> /s	ASTM D 445	2	3.2
Mass fraction of sulphur	ppm	ASTM D 2785	7	15
Volume fraction of aromatics	per cent v/v	ASTM D 1319 40CFR 80.520		35

A.6.3. JAPANESE DIESEL REFERENCE FUEL

Parameter	Unit	Limits		Test method
		Minimum	Maximum	
Cetane index		53	60	JIS K 2280
Density	g/cm <sup>3</sup>	0.815	0.840	JIS K 2249
Distillation:				JIS K 2254
- 50 per cent vol.	°C	255	295	
- 90 per cent vol.	°C	300	345	
- final boiling point	°C	-	370	
Flash point	°C	58		JIS K 2265-3
Kinematic viscosity at 30 °C	mm <sup>2</sup> /s	3.0	4.5	JIS K 2283
Total aromatic	vol. per cent	-	25	JPI HPLC
Polycyclic aromatic	vol. per cent	-	5.0	JPI HPLC
Sulphur content	wt- ppm	-	10	JIS K 2541-1, JIS K 2541-2 JIS K 2541-6, JIS K 2541-7
FAME	per cent	-	0.1	Method promulgated by Notification of Ministry of Economy, Trade and Industry (METI) No. 78 of 2007.
Triglyceride	per cent	-	0.01	

Annex A.7

## EMISSION MOLAR BASED CALCULATIONS

A.7.0. Symbol conversion

## A.7.0.1. General symbols

Annex 7 <sup>(1)</sup>	Annex 8	Unit	Quantity
$A$		$m^2$	Area
$A_t$		$m^2$	Venturi throat cross-sectional area
$a_0$	$b, D_0$	t.b.d. <sup>(7)</sup>	y intercept of the regression line, PDP calibration intercept
$a_1$	$m$	t.b.d. <sup>(7)</sup>	Slope of the regression line
$\beta$	$r_D$	m/m	Ratio of diameters
$C$		-	Coefficient
$C_d$	$C_d$	-	Discharge coefficient
$C_f$		-	Flow coefficient
$d$	$d$	m	Diameter
$DR$	$r_d$	-	Dilution ratio <sup>(2)</sup>
$e$	$e$	g/kWh	Brake specific basis
$e_{gas}$	$e_{gas}$	g/kWh	Specific emission of gaseous components
$e_{PM}$	$e_{PM}$	g/kWh	Specific emission of particulates
$f$		Hz	Frequency
$f_n$	$n$	$min^{-1}, s^{-1}$	Rotational frequency (shaft)
$\gamma$		-	Ratio of specific heats
$K$			Correction factor
$K_s$	$X_0$	s/rev	PDP slip correction factor
$k_{Dr}$	$k_{Dr}$	-	Downward adjustment factor
	$k_h$		Humidity correction factor for NO <sub>x</sub>
$k_r$	$k_r$	-	Multiplicative regeneration factor
$k_{Ur}$	$k_{Ur}$	-	Upward adjustment factor
$\mu$	$\mu$	Pa·s	Dynamic viscosity
$M$	$M$	g/mol	Molar mass <sup>(3)</sup>
$M_{gas}^{(4)}$	$M_{gas}$	g/mol	Molar mass of gaseous components
$m$	$m$	kg	Mass
$\dot{m}$	$q_m$	kg/s	Mass rate
$\nu$		$m^2/s$	Kinematic viscosity
$N$			Total number in series
$n$		mol	Amount of substance
$\dot{n}$		mol/s	Amount of substance rate
$P$	$P$	kW	Power

Annex 7 <sup>(1)</sup>	Annex 8	Unit	Quantity
$p$	$p$	kPa	Pressure
$p_{\text{abs}}$	$p_p$	kPa	Absolute pressure
$p_{\text{H}_2\text{O}}$	$p_r$	kPa	Water vapour pressure
$PF$	$1 - E$	per cent	Penetration fraction ( $E$ = conversion efficiency)
$\dot{V}$	$q_V$	m <sup>3</sup> /s	Volume flow rate
$\rho$	$\rho$	kg/m <sup>3</sup>	Mass density
$r$		-	Ratio of pressures
$Ra$		µm	Average surface roughness
$Re^\#$	$Re$	-	Reynolds number
$RH\%$	$RH$	per cent	Relative humidity
$\sigma$	$\sigma$	-	Standard deviation
$S$		K	Sutherland constant
$T$	$T_a$	K	Absolute temperature
$T$	$T$	°C	Temperature
$T$		N·m	Engine torque
$t$	$t$	s	Time
$\Delta t$	$\Delta t$	s	Time interval
$V$	$V$	m <sup>3</sup>	Volume
$\dot{V}$	$q_V$	m <sup>3</sup> /s	Volume rate
$W$	$W$	kWh	Work
$W_{\text{act}}$	$W_{\text{act}}$	kWh	Actual cycle work of the test cycle
$WF$	$WF$	-	Weighting factor
$w$	$w$	g/g	Mass fraction
$x^{(5)}$	$c$	mol/mol, per cent vol	Amount of substance mole fraction <sup>(6)</sup> / concentration (also in µmol/mol = ppm)
$\bar{x}$		mol/mol	Flow-weighted mean concentration
$y$		-	Generic variable
$\bar{y}$		-	Arithmetic mean
$Z$		-	Compressibility factor

- (1) See subscripts; e.g.:  $\dot{m}_{\text{air}}$  for mass rate of dry air or  $\dot{m}_{\text{fuel}}$  for fuel mass rate.
- (2) Dilution ratio  $r_d$  in Annex 8 and  $DR$  in Annex 7: different symbols but same meaning and same equations. Dilution factor  $D$  in Annex 8 and  $x_{\text{dil}}$  in Annex 7: different symbols but same physical meaning; equation (A.7-47) shows the relationship between  $x_{\text{dil}}$  and  $DR$ .
- (3) See paragraph A.7.1.1. of this section for the values to use for molar masses. In the cases of  $\text{NO}_x$  and HC, the regulations specify effective molar masses based on assumed speciation rather than actual speciation.
- (4) See symbols and abbreviations for the chemical components.
- (5) See specific symbols in the table of chemical balance.
- (6) The mole fractions for THC and NMHC are expressed on a C1 equivalent basis.
- (7) t.b.d.= to be defined

## A.7.0.2. Subscripts

Annex 7	Annex 8 <sup>(1)</sup>	Quantity
abs		Absolute quantity
act	act	Actual quantity
air		Air, dry
atmos		Atmospheric
bkgnd		Background
C		Carbon
cal		Calibration quantity
CFV		Critical flow venturi
cor		Corrected quantity
dil		Dilution air
dexh		Diluted exhaust
dry		Dry quantity
exh		Raw exhaust
exp		Expected quantity
eq		Equivalent quantity
fuel		Fuel
	<i>i</i>	Instantaneous measurement (e.g.: 1 Hz)
<i>i</i>		An individual of a series
idle		Condition at idle
in		Quantity in
init		Initial quantity, typically before an emission test
max		Maximum (i.e. peak) value
meas		Measured quantity
min		Minimum value
mix		Molar mass of air
out		Quantity out
part		Partial quantity
PDP		Positive displacement pump
raw		Raw exhaust
ref		Reference quantity
rev		Revolution
sat		Saturated condition
slip		PDP slip
smpl		Sampling
span		Span quantity
SSV		Subsonic venturi
std		Standard quantity
test		Test quantity
total		Total quantity
uncor		Uncorrected quantity
vac		Vacuum quantity
weight		Calibration weight
wet		Wet quantity
zero		Zero quantity

- (1) In Annex 8 the meaning of subscript is determined by the associated quantity; for example, the subscript "d" can indicate a dry basis as in " $c_d$  = concentration on dry basis", dilution air as in " $p_d$  = saturation vapour pressure of the dilution air" or " $k_{w,d}$  = dry to wet correction factor for the dilution air", dilution ratio as in " $r_d$ ". This is the reason why the column of Annex 8 is nearly empty.

## A.7.0.3. Symbols and abbreviations for the chemical components (used also as a subscript)

Annex 7	Annex 8	Quantity
Ar	Ar	Argon
C1	C1	Carbon 1 equivalent hydrocarbon
CH <sub>4</sub>	CH <sub>4</sub>	Methane
C <sub>2</sub> H <sub>6</sub>	C <sub>2</sub> H <sub>6</sub>	Ethane
C <sub>3</sub> H <sub>8</sub>	C <sub>3</sub> H <sub>8</sub>	Propane
CO	CO	Carbon monoxide
CO <sub>2</sub>	CO <sub>2</sub>	Carbon dioxide
DOP	DOP	Di-octylphthalate
H		Atomic hydrogen
H <sub>2</sub>		Molecular hydrogen
HC	HC	Hydrocarbon
H <sub>2</sub> O	H <sub>2</sub> O	Water
He		Helium
N		Atomic nitrogen
N <sub>2</sub>		Molecular nitrogen
NMHC	NMHC	Non-methane hydrocarbon
NO <sub>x</sub>	NO <sub>x</sub>	Oxides of nitrogen
NO	NO	Nitric oxide
NO <sub>2</sub>	NO <sub>2</sub>	Nitrogen dioxide
O		Atomic oxygen
PM	PM	Particulate matter
S		Sulfur

## A.7.0.4. Symbols and abbreviations for the fuel composition

Annex 7 <sup>(1)</sup>	Annex 8 <sup>(2)</sup>	Quantity
w <sub>C</sub> <sup>(4)</sup>	w <sub>C</sub> <sup>(4)</sup>	Carbon content of fuel, mass fraction [g/g] or [per cent mass]
w <sub>H</sub>	w <sub>H</sub>	Hydrogen content of fuel, mass fraction [g/g] or [per cent mass]
w <sub>N</sub>	w <sub>N</sub>	Nitrogen content of fuel, mass fraction [g/g] or [per cent mass]
w <sub>O</sub>	w <sub>O</sub>	Oxygen content of fuel, mass fraction [g/g] or [per cent mass]
w <sub>S</sub>	w <sub>S</sub>	Sulphur content of fuel, mass fraction [g/g] or [per cent mass]
$\alpha$	$\alpha$	Atomic hydrogen-to-carbon ratio (H/C)
$\beta$	$\varepsilon$	Atomic oxygen-to-carbon ratio (O/C) <sup>(3)</sup>
$\gamma$	$\gamma$	Atomic sulphur-to-carbon ratio (S/C)
$\delta$	$\delta$	Atomic nitrogen-to-carbon ratio (N/C)

(1) Referred to a fuel with chemical formula CH <sub>$\alpha$</sub> O <sub>$\beta$</sub> S <sub>$\gamma$</sub> N <sub>$\delta$</sub>

(2) Referred to a fuel with chemical formula CH <sub>$\alpha$</sub> O <sub>$\varepsilon$</sub> N <sub>$\delta$</sub> S <sub>$\gamma$</sub>

(3) Attention should be paid to the different meaning of symbol  $\beta$  in the two emissions calculation annexes: in Annex 8 it refers to a fuel having the chemical formula CH <sub>$\alpha$</sub> S <sub>$\gamma$</sub> N <sub>$\delta$</sub> O <sub>$\varepsilon$</sub>  (i.e. the formula C <sub>$\beta$</sub> H <sub>$\alpha$</sub> S <sub>$\gamma$</sub> N <sub>$\delta$</sub> O <sub>$\varepsilon$</sub>  where  $\beta = 1$ , assuming one carbon atom per molecule), while in Annex 7 it refers to the oxygen-to-carbon ratio with CH <sub>$\alpha$</sub> O <sub>$\beta$</sub> S <sub>$\gamma$</sub> N <sub>$\delta$</sub> . Then  $\beta$  of Annex 7 corresponds to  $\varepsilon$  of Annex 8.

(4) Mass fraction  $w$  accompanied by the symbol of the chemical component as a subscript.

## A.7.0.5. Symbols for chemical balance used in Annex 7

$x_{\text{dil/exh}}$  = Amount of dilution gas or excess air per mole of exhaust

$x_{\text{H}_2\text{Oexh}}$  = Amount of water in exhaust per mole of exhaust

$x_{\text{Ccombdry}}$  = Amount of carbon from fuel in the exhaust per mole of dry exhaust

$x_{\text{H}_2\text{Oexhdry}}$  = Amount of water in exhaust per dry mole of dry exhaust

$x_{\text{prod/intdry}}$  = Amount of dry stoichiometric products per dry mole of intake air

$x_{\text{dil/exhdry}}$  = Amount of dilution gas and/or excess air per mole of dry exhaust

$x_{\text{int/exhdry}}$  = Amount of intake air required to produce actual combustion products per mole of dry (raw or diluted) exhaust

$x_{\text{raw/exhdry}}$  = Amount of undiluted exhaust, without excess air, per mole of dry (raw or diluted) exhaust

$x_{\text{O}_2\text{intdry}}$  = Amount of intake air  $\text{O}_2$  per mole of dry intake air

$x_{\text{CO}_2\text{intdry}}$  = Amount of intake air  $\text{CO}_2$  per mole of dry intake air

$x_{\text{H}_2\text{Ointdry}}$  = Amount of intake air  $\text{H}_2\text{O}$  per mole of dry intake air

$x_{\text{CO}_2\text{int}}$  = Amount of intake air  $\text{CO}_2$  per mole of intake air

$x_{\text{CO}_2\text{dil}}$  = Amount of dilution gas  $\text{CO}_2$  per mole of dilution gas

$x_{\text{CO}_2\text{dildry}}$  = Amount of dilution gas  $\text{CO}_2$  per mole of dry dilution gas

$x_{\text{H}_2\text{Odildry}}$  = Amount of dilution gas  $\text{H}_2\text{O}$  per mole of dry dilution gas

$x_{\text{H}_2\text{Odil}}$  = Amount of dilution gas  $\text{H}_2\text{O}$  per mole of dilution gas

$x_{\text{[emission]meas}}$  = Amount of measured emission in the sample at the respective gas analyzer

$x_{\text{[emission]dry}}$  = Amount of emission per dry mole of dry sample

$x_{\text{H}_2\text{O[emission]meas}}$  = Amount of water in sample at emission-detection location

$x_{\text{H}_2\text{Oint}}$  = Amount of water in the intake air, based on a humidity measurement of intake air

A.7.1. Basic parameters and relationships

## A.7.1.1. Dry air and chemical species

This annex uses the following values for dry air composition:

$$x_{\text{O}_2\text{airdry}} = 0.209445 \text{ mol/mol}$$

$$x_{\text{CO}_2\text{airdry}} = 0.000375 \text{ mol/mol}$$

This annex uses the following molar masses or effective molar masses of chemical species:

$$M_{\text{air}} = 28.96559 \text{ g/mol (dry air)}$$

$$M_{\text{Ar}} = 39.948 \text{ g/mol (argon)}$$

$$M_{\text{C}} = 12.0107 \text{ g/mol (carbon)}$$

$$M_{\text{CO}} = 28.0101 \text{ g/mol (carbon monoxide)}$$

$$M_{\text{CO}_2} = 44.0095 \text{ g/mol (carbon dioxide)}$$

$$M_{\text{H}} = 1.00794 \text{ g/mol (atomic hydrogen)}$$

$$M_{\text{H}_2} = 2.01588 \text{ g/mol (molecular hydrogen)}$$

$$M_{\text{H}_2\text{O}} = 18.01528 \text{ g/mol (water)}$$

$$M_{\text{He}} = 4.002602 \text{ g/mol (helium)}$$

$$\begin{aligned}M_N &= 14.0067 \text{ g/mol (atomic nitrogen)} \\M_{N_2} &= 28.0134 \text{ g/mol (molecular nitrogen)} \\M_{NMHC} &= 13.875389 \text{ g/mol (non-methane hydrocarbon}^1\text{)} \\M_{NO_x} &= 46.0055 \text{ g/mol (oxides of nitrogen}^2\text{)} \\M_O &= 15.9994 \text{ g/mol (atomic oxygen)} \\M_{O_2} &= 31.9988 \text{ g/mol (molecular oxygen)} \\M_{C_3H_8} &= 44.09562 \text{ g/mol (propane)} \\M_S &= 32.065 \text{ g/mol (sulfur)} \\M_{THC} &= 13.875389 \text{ g/mol (total hydrocarbon}^2\text{)}\end{aligned}$$

- (a) The effective molar masses of THC and NMHC are defined by an atomic hydrogen-to-carbon ratio,  $\alpha$ , of 1.85;
- (b) The effective molar mass of  $NO_x$  is defined by the molar mass of nitrogen dioxide,  $NO_2$ .

This annex uses the following molar gas constant  $R$  for ideal gases:

$$R = 8.314472 \text{ J}/(\text{mol} \cdot \text{K})$$

This annex uses the following ratios of specific heats  $\gamma [J/(\text{kg} \cdot \text{K})]/[J/(\text{kg} \cdot \text{K})]$  for dilution air and diluted exhaust:

$$\gamma_{\text{air}} = 1.399 \text{ (ratio of specific heats for intake air or dilution air)}$$

$$\gamma_{\text{dil}} = 1.399 \text{ (ratio of specific heats for diluted exhaust)}$$

$$\gamma_{\text{dil}} = 1.385 \text{ (ratio of specific heats for raw exhaust)}$$

#### A.7.1.2. Wet air

This section describes how to determine the amount of water in an ideal gas:

##### A.7.1.2.1. Vapour pressure of water

The vapour pressure of water  $p_{H_2O}$  [kPa] for a given saturation temperature condition,  $T_{\text{sat}}$  [K], shall be calculated as follows:

- (a) For humidity measurements made at ambient temperatures from 0 to 100 °C or for humidity measurements made over super-cooled water at ambient temperatures from - 50 to 0 °C:

$$\begin{aligned} \log_{10}(p_{\text{H}_2\text{O}}) = & 10.79574 \cdot \left(1 - \frac{273.16}{T_{\text{sat}}}\right) - 5.02800 \cdot \log_{10}\left(\frac{T_{\text{sat}}}{273.16}\right) + \\ & + 1.50475 \cdot 10^{-4} \cdot \left(1 - 10^{-8.2969 \cdot \left(\frac{T_{\text{sat}}}{273.16} - 1\right)}\right) + 0.42873 \cdot 10^{-3} \cdot \left(10^{4.76955 \cdot \left(1 - \frac{273.16}{T_{\text{sat}}}\right)} - 1\right) - 0.2138602 \end{aligned} \quad (\text{A.7-1})$$

Where:

$p_{\text{H}_2\text{O}}$  = vapour pressure of water at saturation temperature condition [kPa]

$T_{\text{sat}}$  = saturation temperature of water at measured condition [K]

(b) For humidity measurements made over ice at ambient temperatures from (-100 to 0) °C:

$$\log_{10}(p_{\text{sat}}) = -9.096853 \cdot \left(\frac{273.16}{T_{\text{sat}}} - 1\right) - 3.566506 \cdot \log_{10}\left(\frac{273.16}{T_{\text{sat}}}\right) + 0.876812 \cdot \left(1 - \frac{T_{\text{sat}}}{273.16}\right) - 0.2138602 \quad (\text{A.7-2})$$

Where:

$T_{\text{sat}}$  = saturation temperature of water at measured condition [K]

#### A.7.1.2.2. Dew point

If humidity is measured as a dew point, the amount of water in an ideal gas  $x_{\text{H}_2\text{O}}$  [mol/mol] shall be obtained as follows:

$$x_{\text{H}_2\text{O}} = \frac{p_{\text{H}_2\text{O}}}{p_{\text{abs}}} \quad (\text{A.7-3})$$

Where:

$x_{\text{H}_2\text{O}}$  = amount of water in an ideal gas [mol/mol]

$p_{\text{H}_2\text{O}}$  = vapor pressure of water at the measured dew point,  $T_{\text{sat}} = T_{\text{dew}}$  [kPa]

$p_{\text{abs}}$  = wet static absolute pressure at the location of dew point measurement [kPa]

#### A.7.1.2.3. Relative humidity

If humidity is measured as a relative humidity  $RH_a$ , the amount of water of an ideal gas  $x_{\text{H}_2\text{O}}$  [mol/mol] is calculated as follows:

$$x_{\text{H}_2\text{O}} = \frac{RH\% \cdot p_{\text{H}_2\text{O}}}{p_{\text{abs}}} \quad (\text{A.7-4})$$



Where:

- $RH\%$  = relative humidity [per cent]  
 $p_{H_2O}$  = water vapor pressure at 100 per cent relative humidity at the location of relative humidity measurement,  $T_{sat}=T_{amb}$  [kPa]  
 $p_{abs}$  = wet static absolute pressure at the location of relative humidity measurement [kPa]

#### A.7.1.3. Fuel properties

The general chemical formula of fuel is  $CH_\alpha O_\beta S_\gamma N_\delta$  with  $\alpha$  atomic hydrogen-to-carbon ratio (H/C),  $\beta$  atomic oxygen-to-carbon ratio (O/C),  $\gamma$  atomic sulphur-to-carbon ratio (S/C) and  $\delta$  atomic nitrogen-to-carbon ratio (N/C). Based on this formula the carbon mass fraction of fuel  $w_C$  can be calculated. In case of diesel fuel the simple formula  $CH_\alpha O_\beta$  may be used. Default values for fuel composition may be derived from table A.7.1:

Fuel	Atomic hydrogen and oxygen-to-carbon ratios $CH_\alpha O_\beta$	Carbon mass concentration, $w_C$ [g/g]
N. 2 Diesel	$CH_{1.80}O_0$	0.869
N. 1 Diesel	$CH_{1.93}O_0$	0.861

Table A.7.1 - Default values of atomic hydrogen-to-carbon ratio,  $\alpha$ , atomic oxygen-to-carbon ratio,  $\beta$ , and carbon mass fraction of fuel,  $w_C$  for diesel fuels

#### A.7.1.4. Total HC and non-methane HC concentration

##### A.7.1.4.1. THC determination and THC/CH<sub>4</sub> initial contamination corrections

- (a) If THC emissions are required to be determined,  $x_{THC[THC-FID]}$  shall be calculated by using the initial THC contamination concentration  $x_{THC[THC-FID]_{init}}$  from paragraph 7.3.3. as follows:

$$x_{THC[THC-FID]_{cor}} = x_{THC[THC-FID]_{uncorr}} - x_{THC[THC-FID]_{init}} \quad (A.7-5)$$

Where:

- $x_{THC[THC-FID]_{cor}}$  = THC concentration corrected for contamination [mol/mol]  
 $x_{THC[THC-FID]_{uncorr}}$  = THC uncorrected concentration [mol/mol]  
 $x_{THC[THC-FID]_{init}}$  = initial THC contamination concentration [mol/mol]

- (b) For the NMHC determination described in paragraph (b) of this paragraph,  $x_{THC[THC-FID]}$  shall be corrected for initial HC contamination using equation (A.7-5). The initial contamination of the CH<sub>4</sub> sample train may be corrected using equation (A.7-5), substituting in CH<sub>4</sub> concentrations for THC.

## A.7.1.4.2. NMHC determination

To determine NMHC concentration,  $x_{\text{NMHC}}$ , one of the following shall be used:

- (a) If  $\text{CH}_4$  is not measured, NMHC concentrations may be determined as follows:  
The background corrected mass of NMHC shall be compared to background corrected mass of THC. If the background corrected mass of NMHC is greater than 0.98 times the background corrected mass of THC, the background corrected mass of NMHC shall be taken as 0.98 times the background corrected mass of THC. If the NMHC calculations are omitted as described in paragraph A.7.1.4.(c), the background corrected mass of NMHC shall be taken as 0.98 times the background corrected mass of THC.
- (b) For non-methane cutters,  $x_{\text{NMHC}}$  shall be calculated using the non-methane cutter's penetration fractions ( $PF$ ) of  $\text{CH}_4$  and  $\text{C}_2\text{H}_6$  from paragraph 8.1.10.3., and using the HC contamination and wet-to-dry corrected THC concentration  $x_{\text{THC}[\text{THC-FID}]_{\text{cor}}}$  as determined in paragraph (a) of this paragraph.
- (i) The following equation for penetration fractions determined using an NMC configuration as outlined in paragraph 8.1.10.3.4. shall be used:

$$x_{\text{NMHC}} = \frac{x_{\text{THC}[\text{THC-FID}]_{\text{cor}}} - x_{\text{THC}[\text{THC-FID}]} \cdot RF_{\text{CH}_4[\text{THC-FID}]}}{1 - RFPF_{\text{C}_2\text{H}_6[\text{NMC-FID}]} \cdot RF_{\text{CH}_4[\text{THC-FID}]}} \quad (\text{A.7-6})$$

Where:

- $x_{\text{NMHC}}$  = concentration of NMHC
- $x_{\text{THC}[\text{THC-FID}]_{\text{cor}}}$  = concentration of THC, HC contamination and dry-to-wet corrected, as measured by the THC FID during sampling while bypassing the NMC
- $x_{\text{THC}[\text{NMC-FID}]}$  = concentration of THC, HC contamination (optional) and dry-to-wet corrected, as measured by the THC FID during sampling through the NMC
- $RF_{\text{CH}_4[\text{THC-FID}]}$  = response factor of THC FID to  $\text{CH}_4$ , according to paragraph 8.1.10.3.4.
- $RFPF_{\text{C}_2\text{H}_6[\text{NMC-FID}]}$  = non-methane cutter combined ethane response factor and penetration fraction, according to paragraph 8.1.10.3.4.

- (ii) For penetration fractions determined using an NMC configuration as outlined in paragraph 8.1.10.3.5., the following equation shall be used:

$$x_{\text{NMHC}} = \frac{x_{\text{THC}[\text{THC-FID}]_{\text{cor}}} \cdot PF_{\text{CH}_4[\text{NMC-FID}]} - x_{\text{THC}[\text{NMC-FID}]}}{PF_{\text{CH}_4[\text{NMC-FID}]} - PF_{\text{C}_2\text{H}_6[\text{NMC-FID}]}} \quad (\text{A.7-7})$$

Where:

- $x_{\text{NMHC}}$  = concentration of NMHC

$x_{\text{THC}[\text{THC-FID}]_{\text{cor}}}$  = concentration of THC, HC contamination and dry-to-wet corrected, as measured by the THC FID during sampling while bypassing the NMC

$PF_{\text{CH}_4[\text{NMC-FID}]}$  = non-methane cutter  $\text{CH}_4$  penetration fraction, according to paragraph 8.1.10.3.5.

$x_{\text{THC}[\text{NMC-FID}]}$  = concentration of THC, HC contamination (optional) and dry-to-wet corrected, as measured by the THC FID during sampling through the NMC

$PF_{\text{C}_2\text{H}_6[\text{NMC-FID}]}$  = non-methane cutter ethane penetration fraction, according to paragraph 8.1.10.3.5.

(iii) For penetration fractions determined using an NMC configuration as outlined in paragraph 8.1.10.3.6., the following equation shall be used:

$$x_{\text{NMHC}} = \frac{x_{\text{THC}[\text{THC-FID}]_{\text{cor}}} \cdot PF_{\text{CH}_4[\text{NMC-FID}]} - x_{\text{THC}[\text{NMC-FID}]} \cdot RF_{\text{CH}_4[\text{THC-FID}]}}{PF_{\text{CH}_4[\text{NMC-FID}]} - RFPF_{\text{C}_2\text{H}_6[\text{NMC-FID}]} \cdot RF_{\text{CH}_4[\text{THC-FID}]}} \quad (\text{A.7-8})$$

Where:

$x_{\text{NMHC}}$  = concentration of NMHC

$x_{\text{THC}[\text{THC-FID}]_{\text{cor}}}$  = concentration of THC, HC contamination and dry-to-wet corrected, as measured by the THC FID during sampling while bypassing the NMC

$PF_{\text{CH}_4[\text{NMC-FID}]}$  = non-methane cutter  $\text{CH}_4$  penetration fraction, according to paragraph 8.1.10.3.6.

$x_{\text{THC}[\text{NMC-FID}]}$  = concentration of THC, HC contamination (optional) and dry-to-wet corrected, as measured by the THC FID during sampling through the NMC

$RFPF_{\text{C}_2\text{H}_6[\text{NMC-FID}]}$  = non-methane cutter  $\text{CH}_4$  combined ethane response factor and penetration fraction, according to paragraph 8.1.10.3.6.

$RF_{\text{CH}_4[\text{THC-FID}]}$  = response factor of THC FID to  $\text{CH}_4$ , according to paragraph 8.1.10.3.4.

(c) For a gas chromatograph,  $x_{\text{NMHC}}$  shall be calculated using the THC analyzer's response factor ( $RF$ ) for  $\text{CH}_4$ , from paragraph 8.1.10.3., and the HC contamination and wet-to-dry corrected initial THC concentration  $x_{\text{THC}[\text{THC-FID}]_{\text{cor}}}$  as determined in paragraph (a) above as follows:

$$x_{\text{NMHC}} = x_{\text{THC}[\text{THC-FID}]_{\text{cor}}} - RF_{\text{CH}_4[\text{THC-FID}]} \cdot x_{\text{CH}_4} \quad (\text{A.7-9})$$

Where:

$x_{\text{NMHC}}$  = concentration of NMHC

$x_{\text{THC}[\text{THC-FID}]_{\text{cor}}}$  = concentration of THC, HC contamination and dry-to-wet corrected, as measured by the THC FID

$x_{\text{CH}_4}$ =	concentration of CH <sub>4</sub> , HC contamination (optional) and dry-to-wet corrected, as measured by the gas chromatograph FID
$RF_{\text{CH}_4[\text{THC-FID}]}$ =	response factor of THC-FID to CH <sub>4</sub>

#### A.7.1.4.3. Approximation of NMHC from THC

NMHC (non-methane hydrocarbon) emissions can be approximated as 98 percent of THC (total hydrocarbon).

#### A.7.1.5. Flow-weighted mean concentration

In some paragraphs of this annex, it may be necessary to calculate a flow-weighted mean concentration to determine the applicability of certain provisions. A flow-weighted mean is the mean of a quantity after it is weighted proportional to a corresponding flow rate. For example, if a gas concentration is measured continuously from the raw exhaust of an engine, its flow-weighted mean concentration is the sum of the products of each recorded concentration times its respective exhaust molar flow rate, divided by the sum of the recorded flow rate values. As another example, the bag concentration from a CVS system is the same as the flow-weighted mean concentration because the CVS system itself flow-weights the bag concentration. A certain flow-weighted mean concentration of an emission at its standard might be already expected based on previous testing with similar engines or testing with similar equipment and instruments.

### A.7.2. Chemical balances of fuel, intake air, and exhaust

#### A.7.2.1. General

Chemical balances of fuel, intake air and exhaust may be used to calculate flows, the amount of water in their flows, and the wet concentration of constituents in their flows. With one flow rate of either fuel, intake air or exhaust, chemical balances may be used to determine the flows of the other two. For example, chemical balances along with either intake air or fuel flow to determine raw exhaust flow may be used.

#### A.7.2.2. Procedures that require chemical balances

Chemical balances are required to determine the following:

- The amount of water in a raw or diluted exhaust flow,  $x_{\text{H}_2\text{O}_{\text{exh}}}$ , when the amount of water to correct for the amount of water removed by a sampling system is not measured.
- The flow-weighted mean fraction of dilution air in diluted exhaust,  $x_{\text{dil/exh}}$ , when dilution air flow is not measured to correct for background emissions. It has to be noted that if chemical balances are used for this purpose, the exhaust is assumed to be stoichiometric, even if it is not.

### A.7.2.3. Chemical balance procedure

The calculations for a chemical balance involve a system of equations that require iteration. The initial values of up to three quantities shall be guessed: the amount of water in the measured flow,  $x_{\text{H}_2\text{Oexh}}$ , fraction of dilution air in diluted exhaust (or excess air in the raw exhaust),  $x_{\text{dil/exh}}$ , and the amount of products on a C1 basis per dry mole of dry measured flow,  $x_{\text{Ccombdry}}$ . Time-weighted mean values of combustion air humidity and dilution air humidity in the chemical balance may be used; as long as combustion air and dilution air humidity remain within tolerances of  $\pm 0.0025$  mol/mol of their respective mean values over the test interval. For each emission concentration,  $x$ , and amount of water  $x_{\text{H}_2\text{Oexh}}$ , it shall be determined their completely dry concentrations,  $x_{\text{dry}}$  and  $x_{\text{H}_2\text{Oexhdry}}$ . It shall also be used fuel's atomic hydrogen-to-carbon ratio,  $\alpha$ , oxygen-to-carbon ratio,  $\beta$  and carbon mass fraction of fuel,  $w_{\text{C}}$ . For the test fuel,  $\alpha$  and  $\beta$  or the default values in table 1 may be used.

Use the following steps to complete a chemical balance:

- (a) Measured concentrations such as,  $x_{\text{CO}_2\text{meas}}$ ,  $x_{\text{NOmeas}}$ , and  $x_{\text{H}_2\text{Oint}}$ , shall be converted to dry concentrations by dividing them by one minus the amount of water present during their respective measurements; for example:  $x_{\text{H}_2\text{OxCO}_2\text{meas}}$ ,  $x_{\text{H}_2\text{OxNOmeas}}$ , and  $x_{\text{H}_2\text{Oint}}$ . If the amount of water present during a "wet" measurement is the same as the unknown amount of water in the exhaust flow,  $x_{\text{H}_2\text{Oexh}}$ , it has to be iteratively solved for that value in the system of equations. If only total  $\text{NO}_x$  are measured and not  $\text{NO}$  and  $\text{NO}_2$  separately, good engineering judgement shall be used to estimate a split in your total  $\text{NO}_x$  concentration between  $\text{NO}$  and  $\text{NO}_2$  for the chemical balances. The molar concentration of  $\text{NO}_x$ ,  $x_{\text{NO}_x}$ , may be assumed to be 75 per cent  $\text{NO}$  and 25 per cent  $\text{NO}_2$ . For  $\text{NO}_2$  storage aftertreatment systems,  $x_{\text{NO}_x}$  may be assumed to be 25 per cent  $\text{NO}$  and 75 per cent  $\text{NO}_2$ . For calculating the mass of  $\text{NO}_x$  emissions, the molar mass of  $\text{NO}_2$  for the effective molar mass of all  $\text{NO}_x$  species, regardless of the actual  $\text{NO}_2$  fraction of  $\text{NO}_x$ , shall be used.
- (b) Equations in paragraph (c)(4) of this paragraph have to be entered into a computer program to iteratively solve for  $x_{\text{H}_2\text{Oexh}}$ ,  $x_{\text{Ccombdry}}$  and  $x_{\text{dil/exh}}$ . Good engineering judgment shall be used to guess initial values for  $x_{\text{H}_2\text{Oexh}}$ ,  $x_{\text{Ccombdry}}$ , and  $x_{\text{dil/exh}}$ . Guessing an initial amount of water that is about twice the amount of water in your intake or dilution air is recommended. Guessing an initial value of  $x_{\text{Ccombdry}}$  as the sum of your measured  $\text{CO}_2$ ,  $\text{CO}$ , and  $\text{THC}$  values is recommended. Guessing an initial  $x_{\text{dil}}$  between 0.75 and 0.95 ( $0.75 < x_{\text{dil}} < 0.95$ ), such as 0.8 is also recommended. Values in the system of equations shall be iterated until the most recently updated guesses are all within  $\pm 1$  per cent of their respective most recently calculated values.

- (c) The following symbols and subscripts are used in the equation system of paragraph (c) of this paragraph where  $x$  unit is mol/mol:

Symbol	Description
$x_{\text{dil/exh}}$	Amount of dilution gas or excess air per mole of exhaust
$x_{\text{H}_2\text{Oexh}}$	Amount of H <sub>2</sub> O in exhaust per mole of exhaust
$x_{\text{Ccombdry}}$	Amount of carbon from fuel in the exhaust per mole of dry exhaust
$x_{\text{H}_2\text{Oexhdry}}$	Amount of water in exhaust per dry mole of dry exhaust
$x_{\text{prod/intdry}}$	Amount of dry stoichiometric products per dry mole of intake air
$x_{\text{dil/exhdry}}$	Amount of dilution gas and/or excess air per mole of dry exhaust
$x_{\text{int/exhdry}}$	Amount of intake air required to produce actual combustion products per mole of dry (raw or diluted) exhaust
$x_{\text{raw/exhdry}}$	Amount of undiluted exhaust, without excess air, per mole of dry (raw or diluted) exhaust
$x_{\text{O}_2\text{intdry}}$	Amount of intake air O <sub>2</sub> per mole of dry intake air; $x_{\text{O}_2\text{intdry}} = 0.209445$ mol/mol may be assumed
$x_{\text{CO}_2\text{intdry}}$	Amount of intake air CO <sub>2</sub> per mole of dry intake air. $x_{\text{CO}_2\text{intdry}} = 375$ μmol/mol may be used, but measuring the actual concentration in the intake air is recommended
$x_{\text{H}_2\text{Ointdry}}$	Amount of the intake air H <sub>2</sub> O per mole of dry intake air
$x_{\text{CO}_2\text{int}}$	Amount of intake air CO <sub>2</sub> per mole of intake air
$x_{\text{CO}_2\text{dil}}$	Amount of dilution gas CO <sub>2</sub> per mole of dilution gas
$x_{\text{CO}_2\text{dildry}}$	Amount of dilution gas CO <sub>2</sub> per mole of dry dilution gas. If air is used as diluent, $x_{\text{CO}_2\text{dildry}} = 375$ μmol/mol may be used, but measuring the actual concentration in the intake air is recommended
$x_{\text{H}_2\text{Odildry}}$	Amount of dilution gas H <sub>2</sub> O per mole of dry dilution gas
$x_{\text{H}_2\text{Odil}}$	Amount of dilution gas H <sub>2</sub> O per mole of dilution gas
$x_{\text{[emission]meas}}$	Amount of measured emission in the sample at the respective gas analyzer
$x_{\text{[emission]dry}}$	Amount of emission per dry mole of dry sample
$x_{\text{H}_2\text{O[emission]meas}}$	Amount of water in sample at emission-detection location. These values shall be measured or estimated according to paragraph 9.3.2.3.1.
$x_{\text{H}_2\text{Oint}}$	Amount of water in the intake air, based on a humidity measurement of intake air
$\alpha$	Atomic hydrogen-to-carbon ratio of the mixture of fuel(s) (CH <sub><math>\alpha</math></sub> O <sub><math>\beta</math></sub> ) being combusted, weighted by molar consumption
$\beta$	Atomic oxygen-to-carbon ratio of the mixture of fuel(s) (CH <sub><math>\alpha</math></sub> O <sub><math>\beta</math></sub> ) being combusted, weighted by molar consumption

- (d) The following equations shall be used to iteratively solve for  $x_{\text{dil/exh}}$ ,  $x_{\text{H}_2\text{Oexh}}$  and  $x_{\text{Ccombdry}}$ :

$$x_{\text{dil/exh}} = 1 - \frac{x_{\text{raw/exhdry}}}{1 + x_{\text{H}_2\text{Oexhdry}}} \quad (\text{A.7-10})$$

$$x_{\text{H2Oexh}} = \frac{x_{\text{H2Oexhdry}}}{1 + x_{\text{H2Oexhdry}}} \quad (\text{A.7-11})$$

$$x_{\text{Ccombdry}} = x_{\text{CO2dry}} + x_{\text{COdry}} + x_{\text{THCdry}} - x_{\text{CO2dil}} \cdot x_{\text{dil/exhdry}} - x_{\text{CO2int}} \cdot x_{\text{int/exhdry}} \quad (\text{A.7-12})$$

$$x_{\text{H2Oexhdry}} = \frac{\alpha}{2} (x_{\text{Ccombdry}} - x_{\text{THCdry}}) + x_{\text{H2Odil}} \cdot x_{\text{dil/exhdry}} + x_{\text{H2Oint}} \cdot x_{\text{int/exhdry}} \quad (\text{A.7-13})$$

$$x_{\text{dil/exhdry}} = \frac{x_{\text{dil/exh}}}{1 - x_{\text{H2Oexh}}} \quad (\text{A.7-14})$$

$$x_{\text{int/exhdry}} = \frac{1}{2 \cdot x_{\text{O2int}}} \left[ \left( \frac{\alpha}{2} - \beta + 2 \right) (x_{\text{Ccombdry}} - x_{\text{THCdry}}) - (x_{\text{COdry}} - x_{\text{NOdry}} - 2x_{\text{NO2dry}}) \right] \quad (\text{A.7-15})$$

$$x_{\text{raw/exhdry}} = \frac{1}{2} \left[ \left( \frac{\alpha}{2} + \beta \right) (x_{\text{Ccombdry}} - x_{\text{THCdry}}) + (2x_{\text{THCdry}} + x_{\text{COdry}} - x_{\text{NO2dry}}) \right] + x_{\text{int/exhdry}} \quad (\text{A.7-16})$$

$$x_{\text{O2int}} = \frac{0.209820 - x_{\text{CO2intdry}}}{1 + x_{\text{H2Ointdry}}} \quad (\text{A.7-17})$$

$$x_{\text{CO2int}} = \frac{x_{\text{CO2intdry}}}{1 + x_{\text{H2Ointdry}}} \quad (\text{A.7-18})$$

$$x_{\text{H2Ointdry}} = \frac{x_{\text{H2Oint}}}{1 - x_{\text{H2Oint}}} \quad (\text{A.7-19})$$

$$x_{\text{CO2dil}} = \frac{x_{\text{CO2dildry}}}{1 + x_{\text{H2Odildry}}} \quad (\text{A.7-20})$$

$$x_{\text{H2Odildry}} = \frac{x_{\text{H2Odil}}}{1 - x_{\text{H2Odil}}} \quad (\text{A.7-21})$$

$$x_{\text{COdry}} = \frac{x_{\text{COmeas}}}{1 - x_{\text{H2OCOmeas}}} \quad (\text{A.7-22})$$

$$x_{\text{CO2dry}} = \frac{x_{\text{CO2meas}}}{1 - x_{\text{H2OCO2meas}}} \quad (\text{A.7-23})$$

$$x_{\text{NOdry}} = \frac{x_{\text{NOmeas}}}{1 - x_{\text{H}_2\text{ONOmeas}}} \quad (\text{A.7-24})$$

$$x_{\text{NO}_2\text{dry}} = \frac{x_{\text{NO}_2\text{meas}}}{1 - x_{\text{H}_2\text{ONO}_2\text{meas}}} \quad (\text{A.7-25})$$

$$x_{\text{THCdry}} = \frac{x_{\text{THCmeas}}}{1 - x_{\text{H}_2\text{OTHCmeas}}} \quad (\text{A.7-26})$$

At the end of the chemical balance, the molar flow rate  $\dot{n}_{\text{exh}}$  is calculated as specified in paragraphs A.7.3.2. and A.7.4.2.

#### A.7.2.4. NO<sub>x</sub> correction for humidity

All the NO<sub>x</sub> concentrations, including dilution air background concentrations, shall be corrected for intake-air humidity using the following equation:

$$x_{\text{NO}_x\text{cor}} = x_{\text{NO}_x\text{uncor}} \cdot (9.953 \cdot x_{\text{H}_2\text{O}} + 0.832) \quad (\text{A.7-27})$$

Where:

$x_{\text{NO}_x\text{uncor}}$  = uncorrected NO<sub>x</sub> molar concentration in the exhaust gas [ $\mu\text{mol/mol}$ ]

$x_{\text{H}_2\text{O}}$  = amount of water in the intake air [ $\text{mol/mol}$ ]

### A.7.3. Raw gaseous emissions

#### A.7.3.1. Mass of gaseous emissions

To calculate the total mass per test of gaseous emission  $m_{\text{gas}}$  [ $\text{g/test}$ ], its molar concentration shall be multiplied by its respective molar flow and by exhaust gas molar mass; then integration over test cycle shall be performed:

$$m_{\text{gas}} = M_{\text{gas}} \cdot \int \dot{n}_{\text{exhwet}} \cdot x_{\text{gaswet}} \cdot dt \quad (\text{A.7-28})$$

Where:

$M_{\text{gas}}$  = molar mass of the generic gaseous emission [ $\text{g/mol}$ ]

$\dot{n}_{\text{exhwet}}$  = instantaneous exhaust gas molar flow rate on a wet basis [ $\text{mol/s}$ ]

$x_{\text{gaswet}}$  = instantaneous generic gas molar concentration [ $\text{mol/mol}$ ]

$t$  = time [ $\text{s}$ ]

Since equation (A.7-28) has to be solved by numerical integration, it is transformed in:



$$m_{\text{gas}} = M_{\text{gas}} \cdot \left[ \int \dot{n}_{\text{exhwet}} \cdot x_{\text{gaswet}} \cdot dt \right] \Rightarrow m_{\text{gas}} = \frac{1}{f} \cdot M_{\text{gas}} \cdot \sum_{i=1}^N \dot{n}_{\text{exhwet},i} \cdot x_{\text{gaswet},i} \quad (\text{A.7-29})$$

Where:

$M_{\text{gas}}$  = generic emission molar mass [g/mol]

$\dot{n}_{\text{exhwet},i}$  = instantaneous exhaust gas molar flow rate on a wet basis [mol/s]

$x_{\text{gaswet},i}$  = instantaneous generic gas molar concentration [mol/mol]

$f$  = data sampling rate [Hz]

$N$  = number of measurements [-]

General equation may be modified according to which measurement system is used, batch or continuous sampling, and if a varying rather than a constant flow rate is sampled.

- (a) For continuous sampling, in the general case of varying flow rate, the mass of the gaseous emission  $m_{\text{gas}}$  [g/test] shall be calculated by means of the following equation:

$$m_{\text{gas}} = \frac{1}{f} \cdot M_{\text{gas}} \cdot \sum_{i=1}^N \dot{n}_{\text{exhwet},i} \cdot x_{\text{gaswet},i} \quad (\text{A.7-30})$$

Where:

$M_{\text{gas}}$  = generic emission molar mass [g/mol]

$\dot{n}_{\text{exhwet},i}$  = instantaneous exhaust gas molar flow rate on a wet basis [mol/s]

$x_{\text{gaswet},i}$  = instantaneous gaseous emission molar fraction [mol/mol]

$f$  = data sampling rate [Hz]

$N$  = number of measurements [-]

- (b) Still for continuous sampling but in the particular case of constant flow rate the mass of the gaseous emission  $m_{\text{gas}}$  [g/test] shall be calculated by means of the following equation:

$$m_{\text{gas}} = M_{\text{gas}} \cdot \bar{\dot{n}}_{\text{exhwet}} \cdot \bar{x}_{\text{gaswet}} \cdot t_{\text{cycle}} \quad (\text{A.7-31})$$

Where:

$M_{\text{gas}}$  = generic emission molar mass [g/mol]

$\bar{\dot{n}}_{\text{exhwet}}$  = mean exhaust gas molar flow rate on a wet basis [mol/s]

$\bar{x}_{\text{gaswet}}$  = mean gaseous emission molar fraction [mol/mol]

$t_{\text{cycle}}$  = test time interval

- (c) For the batch sampling, regardless the flow rate is varying or constant, the equation (A.7-30) can be simplified as follows:

$$m_{\text{gas}} = \frac{1}{f} \cdot M_{\text{gas}} \cdot \bar{x}_{\text{gaswet}} \cdot \sum_{i=1}^N \dot{n}_{\text{exhwet},i} \quad (\text{A.7-32})$$

Where:

$M_{\text{gas}}$	=	generic emission molar mass [g/mol]
$\dot{n}_{\text{exhwet},i}$	=	instantaneous exhaust gas molar flow rate on a wet basis [mol/s]
$\bar{x}_{\text{gaswet}}$	=	mean gaseous emission molar fraction [mol/mol]
$f$	=	data sampling rate [Hz]
$N$	=	number of measurements [-]

#### A.7.3.2. Dry-to-wet concentration conversion

Parameters of this paragraph are obtained from the results of the chemical balance calculated in paragraph A.7.2. The following relation exists between gas molar concentrations in the measured flow  $x_{\text{gasdry}}$  and  $x_{\text{gaswet}}$  [mol/mol] expressed on a dry and wet basis respectively:

$$x_{\text{gasdry}} = \frac{x_{\text{gaswet}}}{1 - x_{\text{H}_2\text{O}}} \quad (\text{A.7-33})$$

$$x_{\text{gaswet}} = \frac{x_{\text{gasdry}}}{1 + x_{\text{H}_2\text{Odry}}} \quad (\text{A.7-34})$$

Where:

$x_{\text{H}_2\text{O}}$	=	molar fraction of water in the measured flow on a wet basis [mol/mol]
$x_{\text{H}_2\text{O},\text{dry}}$	=	molar fraction of water in the measured flow on a dry basis [mol/mol]

For gaseous emissions a removed water correction shall be performed for the generic concentration  $x$  [mol/mol] as follows:

$$x = x_{[\text{emission}]_{\text{meas}}} \left[ \frac{(1 - x_{\text{H}_2\text{Oexh}})}{1 - x_{\text{H}_2\text{O}[\text{emission}]_{\text{meas}}}} \right] \quad (\text{A.7-35})$$

Where:

$x_{[\text{emission}]_{\text{meas}}}$	=	molar fraction of emission in the measured flow at measurement location [mol/mol]
$x_{\text{H}_2\text{O}[\text{emission}]_{\text{meas}}}$	=	amount of water in the measured flow at the concentration measurement [mol/mol]
$x_{\text{H}_2\text{Oexh}}$	=	amount of water at the flowmeter [mol/mol]

A.7.3.3. Exhaust gas molar flow rate

The flow rate of the raw exhaust gases can be directly measured or can be calculated based on the chemical balance of paragraph A.7.2. Calculation of raw exhaust molar flow rate is performed from measured intake air molar flow rate or fuel mass flow rate. The raw exhaust molar flow rate can be calculated from the sampled emissions,  $\dot{n}_{\text{exh}}$ , based on the measured intake air molar flow rate,  $\dot{n}_{\text{int}}$ , or the measured fuel mass flow rate,  $\dot{m}_{\text{fuel}}$ , and the values calculated using the chemical balance in paragraph A.7.2. It shall be solved for the chemical balance in paragraph A.7.2.(c) at the same frequency that  $\dot{n}_{\text{int}}$  or  $\dot{m}_{\text{fuel}}$  is updated and recorded.

- (a) Crankcase flow rate. The raw exhaust flow can be calculated based on  $\dot{n}_{\text{int}}$  or  $\dot{m}_{\text{fuel}}$  only if at least one of the following is true about crankcase emission flow rate:
- (i) The test engine has a production emission-control system with a closed crankcase that routes crankcase flow back to the intake air, downstream of intake air flow meter.
  - (ii) During emission testing open crankcase flow are routed to the exhaust according to paragraph 6.10.
  - (iii) Open crankcase emissions and flow are measured and added brake-specific emission calculations.
  - (iv) Using emission data or an engineering analysis, it can be demonstrated that neglecting the flow rate of open crankcase emissions does not adversely affect compliance with the applicable standards

- (b) Molar flow rate calculation based on intake air.

Based on  $\dot{n}_{\text{int}}$ , exhaust gas molar flow rate  $\dot{n}_{\text{exh}}$  [mol/s] shall be calculated as follows:

$$\dot{n}_{\text{exh}} = \frac{\dot{n}_{\text{int}}}{\left[ 1 + \frac{(x_{\text{int/exhdry}} - x_{\text{raw/exhdry}})}{(1 + x_{\text{H2Oexhdry}})} \right]} \quad (\text{A.7-36})$$

Where:

- $\dot{n}_{\text{exh}}$  = raw exhaust molar flow rate from which emissions are measured [mol/s]
- $\dot{n}_{\text{int}}$  = intake air molar flow rate including humidity in intake air [mol/s]
- $x_{\text{int/exhdry}}$  = amount of intake air required to produce actual combustion products per mole of dry (raw or diluted) exhaust [mol/mol]
- $x_{\text{raw/exhdry}}$  = amount of undiluted exhaust, without excess air, per mole of dry (raw or diluted) exhaust [mol/mol]
- $x_{\text{H2Oexhdry}}$  = amount of water in exhaust per mole of dry exhaust [mol/mol]

- (c) Molar flow rate calculation based on fuel mass flow rate  
Based on  $\dot{m}_{\text{fuel}}$ ,  $\dot{n}_{\text{exh}}$  [mol/s] shall be calculated as follows:

$$\dot{n}_{\text{exh}} = \frac{\dot{m}_{\text{fuel}} \cdot w_{\text{C}} \cdot (1 + x_{\text{H}_2\text{Oexhdry}})}{M_{\text{C}} \cdot x_{\text{Ccombdry}}} \quad (\text{A.7-37})$$

Where:

- $\dot{n}_{\text{exh}}$  = raw exhaust molar flow rate from which emissions are measured  
 $\dot{m}_{\text{fuel}}$  = fuel flow rate including humidity in intake air [g/s]  
 $w_{\text{C}}$  = carbon mass fraction for the given fuel [g/g]  
 $x_{\text{H}_2\text{Oexhdry}}$  = amount of H<sub>2</sub>O per dry mole of measured flow [mol/mol]  
 $M_{\text{C}}$  = molecular mass of carbon 12.0107 g/mol  
 $x_{\text{Ccombdry}}$  = amount of carbon from fuel in the exhaust per mole of dry exhaust [mol/mol]

#### A.7.4. Diluted gaseous emissions

##### A.7.4.1. Emission mass calculation and background correction

Equations for the calculation of gaseous emissions mass  $m_{\text{gas}}$  [g/test] as a function of molar emissions flow rates are as follows:

- (a) Continuous sampling, varying flow rate

$$m_{\text{gas}} = \frac{1}{f} \cdot M_{\text{gas}} \cdot \sum_{i=1}^N \dot{n}_{\text{exhwet},i} \cdot x_{\text{gaswet},i} \quad (\text{see A.7-29})$$

Continuous sampling, constant flow rate

$$m_{\text{gas}} = M_{\text{gas}} \cdot \bar{\dot{n}}_{\text{exhwet}} \cdot \bar{x}_{\text{gaswet}} \cdot t_{\text{cycle}} \quad (\text{see A.7-31})$$

- (b) Batch sampling, regardless varying flow or constant rate is, the following equation shall be used:

$$m_{\text{gas}} = \frac{1}{f} \cdot M_{\text{gas}} \cdot \bar{x}_{\text{gaswet}} \cdot \sum_{i=1}^N \dot{n}_{\text{exhwet}} \quad (\text{see A.7-32})$$

- (c) In case of diluted exhaust gases calculated values for mass of the pollutants shall be corrected by subtracting the mass of background emissions, due to dilution air:

- (i) Firstly, the molar flow rate of dilution air  $\dot{n}_{\text{airdil}}$  [mol/s] shall be determined over the test interval. This may be a measured quantity or a

quantity calculated from the diluted exhaust flow and the flow-weighted mean fraction of dilution air in diluted exhaust,  $\bar{x}_{\text{dil/exh}}$ ;

- (ii) The total flow of dilution air  $n_{\text{airdil}}$  [mol] shall be multiplied by the mean concentration of background emission. This may be a time-weighted mean or a flow-weighted mean (e.g., a proportionally sampled background). The product of  $n_{\text{airdil}}$  and the mean concentration of a background emission is the total amount of a background emission;
- (iii) If the result is a molar quantity, it shall be converted to a mass of the background emission  $m_{\text{bkgnd}}$  [g] by multiplying it by emission molar mass,  $M_{\text{gas}}$  [g/mol];
- (iv) Total background mass shall be subtracted from total mass to correct for background emissions.
- (v) The total flow of dilution air may be determined by a direct flow measurement. In this case, the total mass of background shall be calculated, using the dilution air flow,  $n_{\text{airdil}}$ . The background mass shall be subtracted from the total mass. The result shall be used in brake-specific emission calculations.
- (vi) The total flow of dilution air may be determined from the total flow of diluted exhaust and a chemical balance of the fuel, intake air, and exhaust as described in paragraph A.7.2. In this case, the total mass of background shall be calculated, using the total flow of diluted exhaust,  $n_{\text{dexh}}$ . Then this result shall be multiplied by the flow-weighted mean fraction of dilution air in diluted exhaust,  $\bar{x}_{\text{dil/exh}}$ .

Considering the two cases (v) and (vi), the following equations shall be used:

$$m_{\text{bkgnd}} = M_{\text{gas}} \cdot x_{\text{gasdil}} \cdot n_{\text{airdil}} \quad \text{or} \quad m_{\text{bkgnd}} = M_{\text{gas}} \cdot \bar{x}_{\text{dil/exh}} \cdot \bar{x}_{\text{bkgnd}} \cdot n_{\text{dexh}} \quad (\text{A.7-38})$$

$$m_{\text{gascor}} = m_{\text{gas}} - m_{\text{bkgnd}} \quad (\text{A.7-39})$$

Where:

$m_{\text{gas}}$  = total mass of the gaseous emission [g]

$m_{\text{bkgnd}}$  = total background masses [g]

$m_{\text{gascor}}$  = mass of gas corrected for background emissions [g]

$M_{\text{gas}}$  = molecular mass of generic gaseous emission [g/mol]

$x_{\text{gasdil}}$  = gaseous emission concentration in dilution air [mol/mol]

$n_{\text{airdil}}$  = dilution air molar flow [mol]

$\bar{x}_{\text{dil/exh}}$  = flow-weighted mean fraction of dilution air in diluted exhaust [mol/mol]

$\bar{x}_{\text{bkgnd}}$  = gas fraction of background [mol/mol]

$n_{\text{dexh}}$  = total flow of diluted exhaust [mol]

## A.7.4.2. Dry-to wet concentration conversion

The same relations for raw gases (paragraph A.7.3.2.) shall be used for dry-to-wet conversion on diluted samples. For dilution air a humidity measurement shall be performed with the aim to calculate its water vapour fraction  $x_{\text{H}_2\text{Odil}} [\text{mol/mol}]$ :

$$x_{\text{H}_2\text{Odil}_{\text{dry}}} = \frac{x_{\text{H}_2\text{Odil}}}{1 - x_{\text{H}_2\text{Odil}}} \quad (\text{see A.7-21})$$

Where:

$x_{\text{H}_2\text{Odil}}$  = water molar fraction in the dilution air flow [mol/mol]

## A.7.4.3. Exhaust molar flow rate

## (a) Calculation via chemical balance

The molar flow rate  $\dot{n}_{\text{exh}}$  [mol/s] can be calculated based on fuel mass flow rate

$\dot{m}_{\text{fuel}}$  :

$$\dot{n}_{\text{exh}} = \frac{\dot{m}_{\text{fuel}} \cdot w_{\text{C}} \cdot (1 + x_{\text{H}_2\text{Oexhdry}})}{M_{\text{C}} \cdot x_{\text{Ccombdry}}} \quad (\text{see A.7-37})$$

Where:

$\dot{n}_{\text{exh}}$  = raw exhaust molar flow rate from which emissions are measured

$\dot{m}_{\text{fuel}}$  = fuel flow rate including humidity in intake air [g/s]

$w_{\text{C}}$  = carbon mass fraction for the given fuel [g/g]

$x_{\text{H}_2\text{Oexhdry}}$  = amount of H<sub>2</sub>O per dry mole of measured flow [mol/mol]

$M_{\text{C}}$  = molecular mass of carbon 12.0107 g/mol

$x_{\text{Ccombdry}}$  = amount of carbon from fuel in the exhaust per mole of dry exhaust [mol/mol]

## (b) Measurement

The exhaust gas molar flow rate may be measured by means of three systems:

(i) PDP molar flow rate. Based upon the speed at which the Positive Displacement Pump (PDP) operates for a test interval, the corresponding slope  $a_1$ , and intercept,  $a_0$  [-], as calculated with the calibration procedure of Appendix 1 to this annex, shall be used to calculate molar flow rate  $\dot{n}$  [mol/s] as follows:

$$\dot{n} = f_{\text{n,PDP}} \cdot \frac{p_{\text{in}} \cdot V_{\text{rev}}}{R \cdot T_{\text{in}}} \quad (\text{A.7-40})$$

Where:

$$V_{\text{rev}} = \frac{a_1}{f_{n,\text{PDP}}} \cdot \sqrt{\frac{p_{\text{out}} - p_{\text{in}}}{p_{\text{in}}}} + a_0 \quad (\text{A.7-41})$$

Where:

$a_1$  = calibration coefficient [ $\text{m}^3/\text{s}$ ]

$a_0$  = calibration coefficient [ $\text{m}^3/\text{rev}$ ]

$p_{\text{in}}, p_{\text{out}}$  = inlet/outlet pressure [Pa]

$R$  = molar gas constant [ $\text{J}/(\text{mol K})$ ]

$T_{\text{in}}$  = inlet temperature [K]

$V_{\text{rev}}$  = PDP pumped volume [ $\text{m}^3/\text{rev}$ ]

$f_{n,\text{PDP}}$  = PDP speed [rev/s]

- (ii) SSV molar flow rate. Based on the  $C_d$  versus  $R_e^\#$  equation determined according to Appendix 1 of this annex, the Sub-Sonic Venturi (SSV) molar flow rate during an emission test  $\dot{n}$  [mol/s] shall be calculated as follows:

$$\dot{n} = C_d \cdot C_f \cdot \frac{A_t \cdot p_{\text{in}}}{\sqrt{Z \cdot M_{\text{mix}} \cdot R \cdot T_{\text{in}}}} \quad (\text{A.7-42})$$

Where:

$p_{\text{in}}$  = inlet pressure [Pa]

$A_t$  = Venturi throat cross-sectional area [ $\text{m}^2$ ]

$R$  = molar gas constant [ $\text{J}/(\text{mol K})$ ]

$T_{\text{in}}$  = inlet temperature [K]

$Z$  = compressibility factor

$M_{\text{mix}}$  = molar mass of diluted exhaust [kg/mol]

$C_d$  = discharge coefficient of the SSV [-]

$C_f$  = flow coefficient of the SSV [-]

- (iii) CFV molar flow rate. To calculate the molar flow rate through one venturi or one combination of venturis, its respective mean  $C_d$  and other constants, determined according to the Appendix 1 to this annex, shall be used. The calculation of its molar flow rate  $\dot{n}$  [mol/s] during an emission test follows:

$$\dot{n} = C_d \cdot C_f \cdot \frac{A_t \cdot p_{\text{in}}}{\sqrt{Z \cdot M_{\text{mix}} \cdot R \cdot T_{\text{in}}}} \quad (\text{A.7-43})$$

Where:

$p_{\text{in}}$  = inlet pressure [Pa]

$A_t$  = Venturi throat cross-sectional area [ $\text{m}^2$ ]

$R$  = molar gas constant [ $\text{J}/(\text{mol K})$ ]

$T_{in}$  = inlet temperature [K]  
 $Z$  = compressibility factor  
 $M_{mix}$  = molar mass of diluted exhaust [kg/mol]  
 $C_d$  = discharge coefficient of the CFV [-]  
 $C_f$  = flow coefficient of the CFV [-]

#### A.7.4.4. Determination of particulates

##### A.7.4.4.1. Sampling

- (a) Sampling from a varying flow rate:  
 Changing exhaust flow rate shall be extracted. The flow rate shall be integrated over a test interval to determine the total flow. The mean PM concentration  $\bar{M}_{PM}$  (which is already in units of mass per mole of sample) shall be multiplied by the total flow to obtain the total mass of PM  $m_{PM}$  [g]:

$$m_{PM} = \bar{M}_{PM} \cdot \sum_{i=1}^N (\dot{n}_i \cdot \Delta t_i) \quad (\text{A.7-44})$$

Where:

$\dot{n}_i$  = instantaneous exhaust molar flow rate [mol/s]

$\bar{M}_{PM}$  = mean PM concentration [g/mol]

$\Delta t_i$  = sampling interval [s]

- (b) Sampling from a constant flow rate  
 If a batch sample from a constant exhaust flow rate is collected, the mean molar flow rate from which the sample is extracted shall be determined. The mean PM concentration shall be multiplied by the total flow to obtain the total mass of PM  $m_{PM}$ [g]:

$$m_{PM} = \bar{M}_{PM} \cdot \bar{\dot{n}} \cdot t_{\text{cycle}} \quad (\text{A.7-45})$$

Where:

$\bar{\dot{n}}$  = mean exhaust molar flow rate [mol/s]

$\bar{M}_{PM}$  = mean PM concentration [g/mol]

$t_{\text{cycle}}$  = test interval [s]

For sampling with a constant dilution ratio ( $DR$ ),  $m_{PM}$  [g] shall be calculated using the following equation:

$$m_{PM} = m_{PMdil} \cdot DR \quad (\text{A.7-46})$$



Where:

$m_{\text{PMdil}}$  = PM mass in dilution air [g]

$DR$  = dilution ratio [-] defined as the ratio between the mass of the emission  $m$  and the mass of diluted exhaust  $m_{\text{dil}}$  ( $DR = m/m_{\text{dil}}$ ). The dilution ratio  $DR$  can be expressed as a function of  $x_{\text{dil}}$ :

$$DR = \frac{1}{1 - x_{\text{dil}}} \quad (\text{A.7-47})$$

#### A.7.4.4.2. Background correction

The same approach as that of paragraph A.7.4.1. shall be applied to correct the mass of PM for the background. Multiplying  $\bar{M}_{\text{PMbkgnd}}$  by the total flow of dilution air, the total background mass of PM ( $m_{\text{PMbkgnd}}$  [g]) is obtained. Subtraction of total background mass from total mass gives background corrected mass of particulates  $m_{\text{PMcor}}$  [g]:

$$m_{\text{PMcor}} = m_{\text{PMuncor}} - \bar{M}_{\text{PMbkgnd}} \cdot n_{\text{airdil}} \quad (\text{A.7-48})$$

Where:

$m_{\text{PMuncor}}$  = uncorrected PM mass [g]

$\bar{M}_{\text{PMbkgnd}}$  = mean PM concentration in dilution air [g/mol]

$n_{\text{airdil}}$  = dilution air molar flow [mol]

### A.7.5. Cycle work and specific emissions

#### A.7.5.1. Gaseous emissions

##### A.7.5.1.1. Transient and ramped modal cycle

Reference is made to paragraphs A.7.3.1. and A.7.4.1. for raw and diluted exhaust respectively. The resulting values for power  $P_i$  [kW] shall be integrated over a test interval. The total work  $W_{\text{act}}$  [kWh] is calculated as follows:

$$W_{\text{act}} = \sum_{i=1}^N P_i \cdot \Delta t_i = \frac{1}{f} \cdot \frac{1}{3600} \cdot \frac{1}{10^3} \frac{2 \cdot \pi}{60} \sum_{i=1}^N (n_i \cdot T_i) \quad (\text{A.7-49})$$

Where:

$P_i$  = instantaneous engine power [kW]

$n_i$  = instantaneous engine speed [rpm]

$T_i$  = instantaneous engine torque [N·m]

$W_{\text{act}}$  = actual cycle work [kWh]

$f$  = data sampling rate [Hz]

$N$  = number of measurements [-]

The specific emissions  $e_{\text{gas}}$  [g/kWh] shall be calculated in the following ways depending on the type of test cycle.

$$e_{\text{gas}} = \frac{m_{\text{gas}}}{W_{\text{act}}} \quad (\text{A.7-50})$$

Where:

$m_{\text{gas}}$  = total mass of emission [g/test]

$W_{\text{act}}$  = cycle work [kWh]

In case of the transient cycle, the final test result  $e_{\text{gas}}$  [g/kWh] shall be a weighted average from cold start test and hot start test by using:

$$e_{\text{gas}} = \frac{(0.1 \cdot m_{\text{cold}}) + (0.9 \cdot m_{\text{hot}})}{(0.1 \cdot W_{\text{actcold}}) + (0.9 \cdot W_{\text{acthot}})} \quad (\text{A.7-51})$$

In case of an infrequent (periodic) exhaust regeneration (paragraph 6.6.2.), the specific emissions shall be corrected with the multiplicative adjustment factor  $k_r$  (equation (6-4)) or with the two separate pairs of adjustment additive factors  $k_{\text{Ur}}$  (upward factor of equation (6-5)) and  $k_{\text{Dr}}$  (downward factor of equation (6-6)).

#### A.7.5.1.2. Steady-state discrete-mode cycle

The specific emissions  $e_{\text{gas}}$  [g/kWh] are calculated as follows:

$$e_{\text{gas}} = \frac{\sum_{i=1}^{N_{\text{mode}}} (\dot{m}_{\text{gas},i} \cdot WF_i)}{\sum_{i=1}^{N_{\text{mode}}} (P_i \cdot WF_i)} \quad (\text{A.7-52})$$

Where:

$\dot{m}_{\text{gas},i}$  = mean emission mass flow rate for the mode  $i$  [g/h]

$P_i$  = engine power for the mode  $i$  [kW] with  $P_i = P_{\text{maxi}} + P_{\text{auxi}}$  (see paragraphs 7.7.1.2. and 6.3.)

$WF_i$  = weighting factor for the mode  $i$  [-]

A.7.5.2. Particulate emissions

A.7.5.2.1. Transient and ramped modal cycles

The particulate specific emissions shall be calculated with equation (A.7-50) where  $e_{\text{gas}}$  [g/kWh] and  $m_{\text{gas}}$  [g/test] are substituted by  $e_{\text{PM}}$  [g/kWh] and  $m_{\text{PM}}$  [g/test] respectively:

$$e_{\text{PM}} = \frac{m_{\text{PM}}}{W_{\text{act}}} \quad (\text{A.7-53})$$

Where:

$m_{\text{PM}}$  = total mass of particulates emission, calculated according to paragraph A.8.3.4. [g/test]

$W_{\text{act}}$  = cycle work [kWh]

The emissions on the transient composite cycle (i.e. cold phase and hot phase) shall be calculated as shown in paragraph A.7.5.1.

A.7.5.2.2. Steady state discrete-mode cycle

The particulate specific emission  $e_{\text{PM}}$  [g/kWh] shall be calculated in the following way:

A.7.5.2.2.1. For the single-filter method

$$e_{\text{PM}} = \frac{\dot{m}_{\text{PM}}}{\sum_{i=1}^N (P_i \cdot WF_i)} \quad (\text{A.7-54})$$

Where:

$P_i$  = engine power for the mode  $i$  [kW] with  $P_i = P_{\text{max}i} + P_{\text{aux}i}$  (see paragraphs 7.7.1.2. and 6.3.)

$WF_i$  = weighting factor for the mode  $i$  [-]

$\dot{m}_{\text{PM}}$  = particulate mass flow rate [g/h]

A.7.5.2.2.2. For the multiple-filter method

$$e_{\text{PM}} = \frac{\sum_{i=1}^N (\dot{m}_{\text{PM}i} \cdot WF_i)}{\sum_{i=1}^N (P_i \cdot WF_i)} \quad (\text{A.7-55})$$

Where:

$P_i$  = engine power for the mode  $i$  [kW] with  $P_i = P_{\max i} + P_{\text{aux}i}$  (see paragraphs 7.7.1.2. and 6.3.)

$WF_i$  = weighting factor for the mode  $i$  [-]

$\dot{m}_{\text{PM}i}$  = particulate mass flow rate at mode  $i$  [g/h]

For the single-filter method, the effective weighting factor,  $WF_{\text{eff}i}$ , for each mode shall be calculated in the following way:

$$WF_{\text{eff}i} = \frac{m_{\text{smpldex}hi} \cdot \overline{\dot{m}_{\text{eqdexhwet}}}}{m_{\text{smpldex}} \cdot \dot{m}_{\text{eqdexhwet}i}} \quad (\text{A.7-56})$$

Where:

$m_{\text{smpldex}hi}$  = mass of the diluted exhaust sample passed through the particulate sampling filters at mode  $i$  [kg]

$m_{\text{smpldex}}$  = mass of the diluted exhaust sample passed through the particulate sampling filters [kg]

$\dot{m}_{\text{eqdexhwet}i}$  = equivalent diluted exhaust gas mass flow rate at mode  $i$  [kg/s]

$\overline{\dot{m}_{\text{eqdexhwet}}}$  = average equivalent diluted exhaust gas mass flow rate [kg/s]

The value of the effective weighting factors shall be within  $\pm 0.005$  (absolute value) of the weighting factors listed in Annex A.1.

Annex A.7. - Appendix 1

DILUTED EXHAUST FLOW (CVS) CALIBRATION

A.7.6. This section describes the calculations for calibrating various flow meters. Paragraph (a) of this section first describes how to convert reference flow meter outputs for use in the calibration equations, which are presented on a molar basis. The remaining paragraphs describe the calibration calculations that are specific to certain types of flow meters.

A.7.6.1. Reference meter conversions. The calibration equations in this section use molar flow rate,  $\dot{n}_{\text{ref}}$ , as a reference quantity. If he adopted reference meter outputs a flow rate in a different quantity, such as standard volume rate,  $\dot{V}_{\text{stdref}}$ , actual volume rate,  $\dot{V}_{\text{actref}}$ , or mass rate,  $\dot{m}_{\text{ref}}$ , the reference meter output shall be converted to a molar flow rate using the following equations, noting that while values for volume rate, mass rate, pressure, temperature, and molar mass may change during an emission test, they should be kept as constant as practical for each individual set point during a flow meter calibration:

$$\dot{n}_{\text{ref}} = \frac{\dot{V}_{\text{stdref}} \cdot p_{\text{std}}}{T_{\text{std}} \cdot R} = \frac{\dot{V}_{\text{actref}} \cdot p_{\text{act}}}{T_{\text{act}} \cdot R} = \frac{\dot{m}_{\text{ref}}}{M_{\text{mix}}} \quad (\text{A.7-57})$$

Where:

- $\dot{n}_{\text{ref}}$  = reference molar flow rate [mol/s]
- $\dot{V}_{\text{stdref}}$  = reference volume flow rate, corrected to a standard pressure and a standard temperature [m<sup>3</sup>/s]
- $\dot{V}_{\text{actref}}$  = reference volume flow rate, at the actual pressure and temperature [m<sup>3</sup>/s]
- $\dot{m}_{\text{ref}}$  = reference mass flow [g/s]
- $p_{\text{std}}$  = standard pressure [Pa]
- $p_{\text{act}}$  = actual pressure of the flow rate [Pa]
- $T_{\text{std}}$  = standard temperature [K]
- $T_{\text{act}}$  = actual temperature of the flow rate [K]
- $R$  = molar gas constant [J/(mol·K)]
- $M_{\text{mix}}$  = molar mass of the diluted flow rate [g/mol]

A.7.6.2. PDP calibration calculations. For each restrictor position, the following values shall be calculated from the mean values determined in paragraph 8.1.8.4., as follows:

(a) PDP volume pumped per revolution,  $V_{\text{rev}}$  (m<sup>3</sup>/rev):

$$V_{\text{rev}} = \frac{\bar{\dot{n}}_{\text{ref}} \cdot R \cdot \bar{T}_{\text{in}}}{\bar{p}_{\text{in}} \cdot \bar{f}_{\text{nPDP}}} \quad (\text{A.7-58})$$

Where:

$\bar{n}_{ref}$  = mean value of reference molar flow rate [mol/s]

$R$  = molar gas constant [J/(mol · K)]

$\bar{T}_{in}$  = mean inlet temperature [K]

$\bar{p}_{in}$  = mean inlet pressure [Pa]

$\bar{f}_{nPDP}$  = mean rotational speed [rev/s]

- (b) PDP slip correction factor,  $K_s$  [s/rev]:

$$K_s = \frac{1}{\bar{f}_{nPDP}} \cdot \sqrt{\frac{\bar{p}_{out} - \bar{p}_{in}}{\bar{p}_{out}}} \quad (\text{A.7-59})$$

Where:

$\bar{n}_{ref}$  = mean reference molar flow rate [mol/s]

$\bar{T}_{in}$  = mean inlet temperature [K]

$\bar{p}_{in}$  = mean inlet pressure [Pa]

$\bar{p}_{out}$  = mean outlet pressure [Pa]

$\bar{f}_{nPDP}$  = mean PDP revolution speed [rev/s]

$R$  = molar gas constant [J/(mol · K)]

- (c) A least-squares regression of PDP volume pumped per revolution,  $V_{rev}$ , versus PDP slip correction factor,  $K_s$ , shall be performed by calculating slope,  $a_1$ , and intercept,  $a_0$ , as described in Annex A.2.
- (d) The procedure in paragraphs (b)(1) through (3) of this section shall be repeated for every speed that PDP is operated.
- (e) The following table illustrates these calculations for different values of  $\bar{f}_{nPDP}$ :

$\bar{f}_{nPDP}$ [rev/min]	$\bar{f}_{nPDP}$ [rev/s]	$a_1$ [m <sup>3</sup> /min]	$a_1$ [m <sup>3</sup> /s]	$a_0$ [m <sup>3</sup> /rev]
755.0	12.58	50.43	0.8405	0.056
987.6	16.46	49.86	0.831	-0.013
1254.5	20.9	48.54	0.809	0.028
1401.3	23.355	47.30	0.7883	-0.061

Table A.7.2 – Example of PDP calibration data

- (f) For each speed at which the PDP is operated, the corresponding slope,  $a_1$ , and intercept,  $a_0$ , shall be used to calculate flow rate during emission testing as described in paragraph A.7.4.3.(b)

- A.7.6.3. Venturi governing equations and permissible assumptions. This section describes the governing equations and permissible assumptions for calibrating a venturi and calculating flow using a venturi. Because a subsonic venturi (SSV) and a critical-flow venturi (CFV) both operate similarly, their governing equations are nearly the same, except for the equation describing their pressure ratio,  $r$  (*i.e.*,  $r_{SSV}$  versus  $r_{CFV}$ ). These governing equations assume one-dimensional isentropic inviscid compressible flow of an ideal gas. In paragraph (c)(4) of this section, other assumptions that may be made are described. If the assumption of an ideal gas for the measured flow is not allowed, the governing equations include a first-order correction for the behaviour of a real gas; namely, the compressibility factor,  $Z$ . If good engineering judgment dictates using a value other than  $Z = 1$ , an appropriate equation of state to determine values of  $Z$  as a function of measured pressures and temperatures may be used, or specific calibration equations may be developed based on good engineering judgment. It shall be noted that the equation for the flow coefficient,  $C_f$ , is based on the ideal gas assumption that the isentropic exponent,  $\gamma$ , is equal to the ratio of specific heats,  $c_p/c_v$ . If good engineering judgment dictates using a real gas isentropic exponent, an appropriate equation of state to determine values of  $\gamma$  as a function of measured pressures and temperatures may be used, or specific calibration equations may be developed. Molar flow rate,  $\dot{n}$  [mol/s], shall be calculated as follows:

$$\dot{n} = C_d \cdot C_f \cdot \frac{A_t \cdot p_{in}}{\sqrt{Z \cdot M_{mix} \cdot R \cdot T_{in}}} \quad (\text{A.7-60})$$

Where:

$C_d$  = Discharge coefficient, as determined in paragraph (c)(1) of this section [-]

$C_f$  = Flow coefficient, as determined in paragraph (c)(2) of this section [-]

$A_t$  = Venturi throat cross-sectional area [m<sup>2</sup>]

$p_{in}$  = Venturi inlet absolute static pressure [Pa]

$Z$  = Compressibility factor [-]

$M_{mix}$  = Molar mass of gas mixture [kg/mol]

$R$  = Molar gas constant [J/(mol·K)]

$T_{in}$  = Venturi inlet absolute temperature [K]

- (a) Using the data collected in paragraph 8.1.8.4.,  $C_d$  is calculated using the following equation:

$$C_d = \dot{n}_{ref} \cdot \frac{\sqrt{Z \cdot M_{mix} \cdot R \cdot T_{in}}}{C_f \cdot A_t \cdot p_{in}} \quad (\text{A.7-61})$$

Where:

$\dot{n}_{ref}$  = reference molar flow rate [mol/s]

Other symbols as per equation (A.7-60).

- (b)  $C_f$  shall be determined using one of the following methods:
- (i) For CFV flow meters only,  $C_{fCFV}$  is derived from the following table based on values for  $\beta$  (ratio of venturi throat to inlet diameters) and  $\gamma$  (ratio of specific heats of the gas mixture), using linear interpolation to find intermediate values:

$C_{fCFV}$		
$\beta$	$\gamma_{exh}=1.385$	$\gamma_{dexh}=\gamma_{air}=1.399$
0.000	0.6822	0.6846
0.400	0.6857	0.6881
0.500	0.6910	0.6934
0.550	0.6953	0.6977
0.600	0.7011	0.7036
0.625	0.7047	0.7072
0.650	0.7089	0.7114
0.675	0.7137	0.7163
0.700	0.7193	0.7219
0.720	0.7245	0.7271
0.740	0.7303	0.7329
0.760	0.7368	0.7395
0.770	0.7404	0.7431
0.780	0.7442	0.7470
0.790	0.7483	0.7511
0.800	0.7527	0.7555
0.810	0.7573	0.7602
0.820	0.7624	0.7652
0.830	0.7677	0.7707
0.840	0.7735	0.7765
0.850	0.7798	0.7828

Table A.7.3 –  $C_{fCFV}$  versus  $\beta$  and  $\gamma$  for CFV flow meters

- (ii) For any CFV or SSV flow meter, the following equation may be used to calculate  $C_f$ :

$$C_f = \left[ \frac{2 \cdot \gamma \cdot \left( r^{\frac{\gamma-1}{\gamma}} - 1 \right)}{(\gamma - 1) \cdot \left( \beta^4 - r^{\frac{-2}{\gamma}} \right)} \right]^{\frac{1}{2}} \quad (\text{A.7-62})$$



Where:

$\gamma$  = isentropic exponent [-]. For an ideal gas, this is the ratio of specific heats of the gas mixture,  $c_p/c_V$

$r$  = pressure ratio, as determined in paragraph (c)(3) of this section

$\beta$  = ratio of venturi throat to inlet diameters

(c) The pressure ratio  $r$  shall be calculated as follows:

(i) For SSV systems only,  $r_{SSV}$  is calculated using the following equation:

$$r_{SSV} = 1 - \frac{\Delta p_{SSV}}{p_{in}} \quad (A.7-63)$$

Where:

$\Delta p_{SSV}$  = differential static pressure; venturi inlet minus venturi throat [Pa]

(ii) For CFV systems only,  $r_{CFV}$  shall be calculated iteratively using the following equation:

$$r_{CFV}^{\frac{1-\gamma}{\gamma}} + \left( \frac{\gamma-1}{2} \right) \cdot \beta^4 \cdot r_{CFV}^{\frac{2}{\gamma}} = \frac{\gamma+1}{2} \quad (A.7-64)$$

(d) Any of the following simplifying assumptions of the governing equations may be made, or good engineering judgment may be used to develop more appropriate values for testing:

(i) For emission testing over the full ranges of raw exhaust, diluted exhaust and dilution air, the gas mixture may be assumed to behave as an ideal gas:  $Z = 1$ .

(ii) For the full range of raw exhaust a constant ratio of specific heats of  $\gamma = 1.385$  may be assumed.

(iii) For the full range of diluted exhaust and air (e.g., calibration air or dilution air), a constant ratio of specific heats of  $\gamma = 1.399$  may be assumed.

(iv) For the full range of diluted exhaust and air, the molar mass of the mixture,  $M_{mix}$  [g/mol], may be considered as a function only of the amount of water in the dilution air or calibration air,  $x_{H_2O}$ , determined as described in paragraph A.7.1.2., as follows:

$$M_{mix} = M_{air} \cdot (1 - x_{H_2O}) + M_{H_2O} \cdot (x_{H_2O}) \quad (A.7-65)$$

Where:

$M_{air} = 28.96559$  g/mol

$M_{H_2O} = 18.01528$  g/mol

$x_{H_2O}$  = amount of water in the dilution or calibration air [mol/mol]

- (v) For the full range of diluted exhaust and air, a constant molar mass of the mixture,  $M_{\text{mix}}$ , may be assumed for all calibration and all testing as long as assumed molar mass differs no more than  $\pm 1$  per cent from the estimated minimum and maximum molar mass during calibration and testing. This assumption may be made if sufficient control of the amount of water in calibration air and in dilution air is ensured, or if sufficient water is removed from both calibration air and dilution air. The following table gives examples of permissible ranges of dilution air dew point versus calibration air dew point:

If calibration $T_{\text{dew}}$ ( $^{\circ}\text{C}$ ) is...	the following constant $M_{\text{mix}}$ (g/mol) is assumed	for the following ranges of $T_{\text{dew}}$ ( $^{\circ}\text{C}$ ) during emission tests <sup>(a)</sup>
dry	28.96559	dry to 18
0	28.89263	dry to 21
5	28.86148	dry to 22
10	28.81911	dry to 24
15	28.76224	dry to 26
20	28.68685	-8 to 28
25	28.58806	12 to 31
30	28.46005	23 to 34
<sup>(a)</sup> Range valid for all calibration and emission testing over the atmospheric pressure range (80,000 to 103,325) kPa.		

Table A.7.4 – Examples of dilution air and calibration air dew points at which a constant  $M_{\text{mix}}$  may be assumed

#### A.7.7.1 SSV calibration

- (a) Molar based approach. To calibrate an SSV flow meter the following steps shall be performed:
- (i) The Reynolds number,  $Re^{\#}$ , for each reference molar flow rate, shall be calculated using the throat diameter of the venturi,  $d_t$ . Because the dynamic viscosity,  $\mu$ , is needed to compute  $Re^{\#}$ , a specific viscosity model may be used to determine  $\mu$  for calibration gas (usually air), using good engineering judgment. Alternatively, the Sutherland three-coefficient viscosity model may be used to approximate  $\mu$ :

$$Re^{\#} = \frac{4 \cdot M_{\text{mix}} \cdot \dot{n}_{\text{ref}}}{\pi \cdot d_t \cdot \mu} \quad (\text{A.7-66})$$

Where:

$d_t$  = diameter of the SSV throat [m]

$M_{\text{mix}}$  = mixture molar mass [kg/mol]

$\dot{n}_{\text{stdref}}$  = reference molar flow rate [mol/s]

and, using the Sutherland three-coefficient viscosity model:

$$\mu = \mu_0 \left( \frac{T_{in}}{T_0} \right)^{\frac{3}{2}} \cdot \left( \frac{T_0 + S}{T_{in} + S} \right) \quad (\text{A.7-67})$$

Where:

$\mu$  = Dynamic viscosity of calibration gas [kg/(m·s)]

$\mu_0$  = Sutherland reference viscosity [kg/(m·s)]

$S$  = Sutherland constant [K]

$T_0$  = Sutherland reference temperature [K]

$T_{in}$  = Absolute temperature at the venturi inlet [K]

Gas <sup>(a)</sup>	$\mu_0$	$T_0$	$S$	Temp range within $\pm 2$ per cent error	Pressure limit
	kg/(m·s)	K	K	K	kPa
Air	$1.716 \times 10^{-5}$	273	111	170 to 1900	$\leq 1800$
CO <sub>2</sub>	$1.370 \times 10^{-5}$	273	222	190 to 1700	$\leq 3600$
H <sub>2</sub> O	$1.12 \times 10^{-5}$	350	1,064	360 to 1500	$\leq 10000$
O <sub>2</sub>	$1.919 \times 10^{-5}$	273	139	190 to 2000	$\leq 2500$
N <sub>2</sub>	$1.663 \times 10^{-5}$	273	107	100 to 1500	$\leq 1600$
<sup>(a)</sup> Tabulated parameters only for the pure gases, as listed, shall be used. Parameters to calculate viscosities of gas mixtures shall not be combined.					

Table A.7.5 – Sutherland three-coefficient viscosity model parameters

- (ii) An equation for  $C_d$  versus  $Re^\#$  shall be created, using paired values of ( $Re^\#, C_d$ ).  $C_d$  is calculated according to equation (A.7-61), with  $C_f$  obtained from equation (A.7-62), or any mathematical expression may be used, including a polynomial or a power series. The following equation is an example of a commonly used mathematical expression for relating  $C_d$  and  $Re^\#$ :

$$C_d = a_0 - a_1 \cdot \sqrt{\frac{10^6}{Re^\#}} \quad (\text{A.7-68})$$

- (iii) A least-squares regression analysis shall be performed to determine the best-fit coefficients to the equation and calculate the equation's regression statistics, the standard estimate error  $SEE$  and the coefficient of determination  $r^2$ , according to Annex A.2.
- (iv) If the equation meets the criteria of  $SEE < 0.5\% \cdot \dot{n}_{ref\ max}$  (or  $\dot{m}_{ref\ max}$ ) and  $r^2 \geq 0.995$ , the equation may be used to determine  $C_d$  for emission tests, as described in A.7.4.3.(b).

- (v) If the *SEE* and  $r^2$  criteria are not met, good engineering judgment may be used to omit calibration data points to meet the regression statistics. At least seven calibration data points shall be used to meet the criteria.
- (vi) If omitting points does not resolve outliers, corrective action shall be taken. For example, another mathematical expression for the  $C_d$  versus  $Re^\#$  equation shall be selected, leaks are to be checked, or the calibration process has to be repeated. If the process shall be repeated, tighter tolerances shall be applied to measurements and more time for flows to stabilize shall be allowed.
- (vii) Once the equation meets the regression criteria, the equation may be used only to determine flow rates that are within the range of the reference flow rates used to meet the  $C_d$  versus  $Re^\#$  equation's regression criteria.

#### A.7.7.2. CFV calibration

- (a) Molar based approach. Some CFV flow meters consist of a single venturi and some consist of multiple venturis, where different combinations of venturis are used to meter different flow rates. For CFV flow meters that consist of multiple venturis, either calibration of each venturi independently to determine a separate discharge coefficient,  $C_d$ , for each venturi, or calibration of each combination of venturis as one venture may be performed. In the case where a combination of venturis is calibrated, the sum of the active venturi throat areas is used as  $A_t$ , the square root of the sum of the squares of the active venturi throat diameters as  $d_t$ , and the ratio of the venturi throat to inlet diameters as the ratio of the venturi throat to inlet diameters as the ratio of the square root of the sum of the active venture throat diameters ( $d_t$ ) to the diameter of the common entrance to all of the venturis ( $D$ ). To determine the  $C_d$  for a single venturi or a single combination of venturis, the following steps shall be performed:
  - (i) With the data collected at each calibration set point to an individual  $C_d$  for each point shall be calculated using equation (A.7-60).
  - (ii) The mean and standard deviation of all the  $C_d$  values shall be calculated according to equations (A.2-1) and (A.2-2).
  - (iii) If the standard deviation of all the  $C_d$  values is less than or equal to 0.3 per cent of the mean  $C_d$ , then the mean  $C_d$  shall be used in equation (A.7-43), and the CFV shall be used only down to the lowest  $r$  measured during calibration.

$$r = 1 - (\Delta p / p_{in}) \quad (\text{A.7-69})$$

- (iv) If the standard deviation of all the  $C_d$  values exceeds 0.3 per cent of the mean  $C_d$ , the  $C_d$  values corresponding to the data point collected at the lowest  $r$  measured during calibration shall be omitted.
- (v) If the number of remaining data points is less than seven, corrective action shall be taken by checking calibration data or repeating the calibration process. If the calibration process is repeated, checking for

leaks, applying tighter tolerances to measurements and allowing more time for flows to stabilize, is recommended.

- (vi) If the number of remaining  $C_d$  values is seven or greater, the mean and standard deviation of the remaining  $C_d$  values shall be recalculated.
- (vii) If the standard deviation of the remaining  $C_d$  values is less than or equal to 0.3 per cent of the mean of the remaining  $C_d$ , that mean  $C_d$  shall be used in equation (A.7-43) and the CFV values only down to the lowest  $r$  associated with the remaining  $C_d$  shall be used.
- (viii) If the standard deviation of the remaining  $C_d$  still exceeds 0.3 per cent of the mean of the remaining  $C_d$  values, the steps in paragraph (e) (4) through (8) of this section shall be repeated.

Annex A.7 - Appendix 2

DRIFT CORRECTION

A.7.8.1. Scope and frequency

The calculations in this section are performed to determine if gas analyzer drift invalidates the results of a test interval. If drift does not invalidate the results of a test interval, the test interval's gas analyzer responses shall be corrected for drift according to this section. The drift-corrected gas analyzer responses shall be used in all subsequent emission calculations. The acceptable threshold for gas analyzer drift over a test interval is specified in paragraph 8.2.2.2.

A.7.8.2. Correction principles

The calculations in this section utilize a gas analyzer's responses to reference zero and span concentrations of analytical gases, as determined sometime before and after a test interval. The calculations correct the gas analyzer's responses that were recorded during a test interval. The correction is based on an analyzer's mean responses to reference zero and span gases, and it is based on the reference concentrations of the zero and span gases themselves. Validation and correction for drift shall be performed as follows:

A.7.8.3. Drift validation

After applying all the other corrections—except drift correction—to all the gas analyzer signals, brake-specific emissions shall be calculated according to A.7.5. Then all gas analyzer signals shall be corrected for drift according to this section. Brake-specific emissions shall be recalculated using all of the drift-corrected gas analyzer signals. The brake-specific emission results shall be validated and reported before and after drift correction according to paragraph 8.2.2.2.

A.7.8.4. Drift correction

All gas analyzer signals shall be corrected as follows:

- (a) Each recorded concentration,  $x_i$ , shall be corrected for continuous sampling or for batch sampling,  $\bar{x}$ .
- (b) Correction for drift shall be done using the following equation:

$$x_{\text{driftcor}} = x_{\text{refzero}} + (x_{\text{refspan}} - x_{\text{refzero}}) \frac{2x_i - (x_{\text{prezero}} + x_{\text{postzero}})}{(x_{\text{prespan}} + x_{\text{postspan}}) - (x_{\text{prezero}} + x_{\text{postzero}})} \quad (\text{A.7-70})$$

Where:

$x_{\text{driftcor}}$	=	concentration corrected for drift [ $\mu\text{mol/mol}$ ]
$x_{\text{refzero}}$	=	reference concentration of the zero gas, which is usually zero unless known to be otherwise [ $\mu\text{mol/mol}$ ]
$x_{\text{refspan}}$	=	reference concentration of the span gas [ $\mu\text{mol/mol}$ ]
$x_{\text{prespan}}$	=	pre-test interval gas analyzer response to the span gas concentration [ $\mu\text{mol/mol}$ ]
$x_{\text{postspan}}$	=	post-test interval gas analyzer response to the span gas concentration [ $\mu\text{mol/mol}$ ]
$x_i$ or $\bar{x}$	=	concentration recorded, i.e. measured, during test, before drift correction [ $\mu\text{mol/mol}$ ]
$x_{\text{prezero}}$	=	pre-test interval gas analyzer response to the zero gas concentration [ $\mu\text{mol/mol}$ ]
$x_{\text{postzero}}$	=	post-test interval gas analyzer response to the zero gas concentration [ $\mu\text{mol/mol}$ ]

- (c) For any pre-test interval concentrations, concentrations determined most recently before the test interval shall be used. For some test intervals, the most recent pre-zero or pre-span might have occurred before one or more previous test intervals.
- (d) For any post-test interval concentrations, concentrations determined most recently after the test interval shall be used. For some test intervals, the most recent post-zero or post-span might have occurred after one or more subsequent test intervals.
- (e) If any pre-test interval analyzer response to the span gas concentration,  $x_{\text{prespan}}$ , is not recorded,  $x_{\text{prespan}}$  shall be set equal to the reference concentration of the span gas:  $x_{\text{prespan}} = x_{\text{refspan}}$ .
- (f) If any pre-test interval analyzer response to the zero gas concentration,  $x_{\text{prezero}}$ , is not recorded,  $x_{\text{prezero}}$  shall be set equal to the reference concentration of the zero gas:  $x_{\text{prezero}} = x_{\text{refzero}}$ .
- (g) Usually the reference concentration of the zero gas,  $x_{\text{refzero}}$ , is zero:  $x_{\text{refzero}} = 0 \mu\text{mol/mol}$ . However, in some cases it might be known that  $x_{\text{refzero}}$  has a non-zero concentration. For example, if a  $\text{CO}_2$  analyzer is zeroed using ambient air, the default ambient air concentration of  $\text{CO}_2$ , which is  $375 \mu\text{mol/mol}$ , may be used. In this case,  $x_{\text{refzero}} = 375 \mu\text{mol/mol}$ . When an analyzer is zeroed using a non-zero  $x_{\text{refzero}}$ , the analyzer shall be set to output the actual  $x_{\text{refzero}}$  concentration. For example, if  $x_{\text{refzero}} = 375 \mu\text{mol/mol}$ , the analyzer shall be set to output a value of  $375 \mu\text{mol/mol}$  when the zero gas is flowing to the analyzer.

Annex A.8

## MASS BASED EMISSION CALCULATIONS

A.8.0. Symbol conversion

## A.8.0.1. General symbols

Annex 8	Annex 7	Unit	Quantity
$b, D_0$	$a_0$	t.b.d. <sup>(3)</sup>	y intercept of the regression line
$m$	$a_1$	t.b.d. <sup>(3)</sup>	Slope of the regression line
$A/F_{st}$		-	Stoichiometric air to fuel ratio
$C_d$	$C_d$	-	Discharge coefficient
$c$	$x$	ppm, % vol	Concentration ( $\mu\text{mol/mol} = \text{ppm}$ )
$c_d$	<sup>(1)</sup>	ppm, % vol	Concentration on dry basis
$c_w$	<sup>(1)</sup>	ppm, % vol	Concentration on wet basis
$c_b$	<sup>(1)</sup>	ppm, % vol	Background concentration
$D$	$x_{dil}$	-	Dilution factor <sup>(2)</sup>
$D_0$		$\text{m}^3/\text{rev}$	PDP calibration intercept
$d$	$d$	m	Diameter
$d_V$		m	Throat diameter of venturi
$e$	$e$	g/kWh	Brake specific basis
$e_{gas}$	$e_{gas}$	g/kWh	Specific emission of gaseous components
$e_{PM}$	$e_{PM}$	g/kWh	Specific emission of particulates
$E$	$1 - PF$	per cent	Conversion efficiency ( $PF = \text{Penetration fraction}$ )
$F_s$		-	Stoichiometric factor
$f_c$		-	Carbon factor
$H$		g/kg	Absolute humidity
$K_V$		$\left[ \left( \sqrt{K} \cdot \text{m}^4 \cdot \text{s} \right) / \text{kg} \right]$	CFV calibration function
$k_f$		$\text{m}^3/\text{kg fuel}$	Fuel specific factor
$k_h$		-	Humidity correction factor for $\text{NO}_x$ , diesel engines
$k_{Dr}$	$k_{Dr}$	-	Downward adjustment factor
$k_r$	$k_r$	-	Multiplicative regeneration factor
$k_{Ur}$	$k_{Ur}$	-	Upward adjustment factor
$k_{w,a}$		-	Dry to wet correction factor for the intake air
$k_{w,d}$		-	Dry to wet correction factor for the dilution air
$k_{w,e}$		-	Dry to wet correction factor for the diluted exhaust gas
$k_{w,r}$		-	Dry to wet correction factor for the raw exhaust gas
$\mu$	$\mu$	Pa·s	Dynamic viscosity
$M$	$M$	g/mol	Molar mass <sup>(3)</sup>



Annex 8	Annex 7	Unit	Quantity
$M_a$	<sup>(1)</sup>	g/mol	Molar mass of the intake air
$M_e$	<sup>(1)</sup>	g/mol	Molar mass of the exhaust
$M_{\text{gas}}$	$M_{\text{gas}}$	g/mol	Molar mass of gaseous components
$m$	$m$	kg	Mass
$q_m$	$\dot{m}$	kg/s	Mass rate
$m_d$	<sup>(1)</sup>	kg	Mass of the dilution air sample passed through the particulate sampling filters
$m_{\text{ed}}$	<sup>(1)</sup>	kg	Total diluted exhaust mass over the cycle
$m_{\text{edf}}$	<sup>(1)</sup>	kg	Mass of equivalent diluted exhaust gas over the test cycle
$m_{\text{ew}}$	<sup>(1)</sup>	kg	Total exhaust mass over the cycle
$m_f$	<sup>(1)</sup>	mg	Particulate sample mass collected
$m_{f,d}$	<sup>(1)</sup>	mg	Particulate sample mass of the dilution air collected
$m_{\text{gas}}$	$m_{\text{gas}}$	g	Mass of gaseous emissions over the test cycle
$m_{\text{PM}}$	$m_{\text{PM}}$	g	Mass of particulate emissions over the test cycle
$m_{\text{se}}$	<sup>(1)</sup>	kg	Exhaust sample mass over the test cycle
$m_{\text{sed}}$	<sup>(1)</sup>	kg	Mass of diluted exhaust gas passing the dilution tunnel
$m_{\text{sep}}$	<sup>(1)</sup>	kg	Mass of diluted exhaust gas passing the particulate collection filters
$m_{\text{ssd}}$		kg	Mass of secondary dilution air
$n$	$f_n$	min <sup>-1</sup>	Engine rotational speed
$n_p$		r/s	PDP pump speed
$P$	$P$	kW	Power
$p$	$p$	kPa	Pressure
$p_a$		kPa	Dry atmospheric pressure
$p_b$		kPa	Total atmospheric pressure
$p_d$		kPa	Saturation vapour pressure of the dilution air
$p_p$	$p_{\text{abs}}$	kPa	Absolute pressure
$p_r$	$p_{\text{H}_2\text{O}}$	kPa	Water vapour pressure
$p_s$		kPa	Dry atmospheric pressure
$1 - E$	$PF$	per cent	Penetration fraction
$q_{\text{mad}}$	$\dot{m}$ <sup>(1)</sup>	kg/s	Intake air mass flow rate on dry basis
$q_{\text{maw}}$	<sup>(1)</sup>	kg/s	Intake air mass flow rate on wet basis
$q_{\text{mCe}}$	<sup>(1)</sup>	kg/s	Carbon mass flow rate in the raw exhaust gas
$q_{\text{mCf}}$	<sup>(1)</sup>	kg/s	Carbon mass flow rate into the engine
$q_{\text{mCp}}$	<sup>(1)</sup>	kg/s	Carbon mass flow rate in the partial flow dilution system
$q_{\text{mdew}}$	<sup>(1)</sup>	kg/s	Diluted exhaust gas mass flow rate on wet basis
$q_{\text{mdw}}$	<sup>(1)</sup>	kg/s	Dilution air mass flow rate on wet basis

Annex 8	Annex 7	Unit	Quantity
$q_{medf}$	(1)	kg/s	Equivalent diluted exhaust gas mass flow rate on wet basis
$q_{mew}$	(1)	kg/s	Exhaust gas mass flow rate on wet basis
$q_{mex}$	(1)	kg/s	Sample mass flow rate extracted from dilution tunnel
$q_{mf}$	(1)	kg/s	Fuel mass flow rate
$q_{mp}$	(1)	kg/s	Sample flow of exhaust gas into partial flow dilution system
$q_V$	$\dot{V}$	m <sup>3</sup> /s	Volume flow rate
$q_{V_{CVS}}$	(1)	m <sup>3</sup> /s	CVS volume rate
$q_{V_s}$	(1)	dm <sup>3</sup> /min	System flow rate of exhaust analyzer system
$q_{V_t}$	(1)	cm <sup>3</sup> /min	Tracer gas flow rate
$\rho$	$\rho$	kg/m <sup>3</sup>	Mass density
$\rho_e$		kg/m <sup>3</sup>	Exhaust gas density
$r_d$	$DR$	-	Dilution ratio <sup>(2)</sup>
$RH$		per cent	Relative humidity
$r_D$	$\beta$	m/m	Ratio of diameters (CVS systems)
$r_p$		-	Pressure ratio of SSV
$Re$	$Re^\#$	-	Reynolds number
$\sigma$	$\sigma$	-	Standard deviation
$T$	$T$	°C	Temperature
$T_a$		K	Absolute temperature
$t$	$t$	s	Time
$\Delta t$	$\Delta t$	s	Time interval
$u$		-	Ratio between densities of gas component and exhaust gas
$V$	$V$	m <sup>3</sup>	Volume
$q_V$	$\dot{V}$	m <sup>3</sup> /s	Volume rate
$V_0$		m <sup>3</sup> /r	PDP gas volume pumped per revolution
$W$	$W$	kWh	Work
$W_{act}$	$W_{act}$	kWh	Actual cycle work of the test cycle
$WF$	$WF$	-	Weighting factor
$w$	$w$	g/g	Mass fraction
$X_0$	$K_s$	s/rev	PDP calibration function
$\bar{y}$	$\bar{y}$		Arithmetic mean

(1) See subscripts; e.g.:  $\dot{m}_{air}$  for mass rate of dry air,  $\dot{m}_{fuel}$  for fuel mass rate, etc.

(2) Dilution ratio  $r_d$  in Annex 8 and  $DR$  in Annex 7: different symbols but same meaning and same equations. Dilution factor  $D$  in Annex 8 and  $x_{dil}$  in Annex 7: different symbols but same physical meaning; equation (A.7-47) shows the relationship between  $x_{dil}$  and  $DR$ .

(3) t.b.d.= to be defined

## A.8.0.2. Subscripts

Annex 8 <sup>(1)</sup>	Annex 7	Quantity
act	act	Actual quantity
<i>i</i>		Instantaneous measurement (e.g.: 1 Hz)
	<i>i</i>	An individual of a series

- (1) In Annex 8 the meaning of subscript is determined by the associated quantity; for example, the subscript "d" can indicate a dry basis as in " $c_d$  = concentration on dry basis", dilution air as in " $p_d$  = saturation vapour pressure of the dilution air" or " $k_{w,d}$  = dry to wet correction factor for the dilution air", dilution ratio as in " $r_d$ ".

## A.8.0.3. Symbols and abbreviations for the chemical components (used also as a subscript)

Annex 8	Annex 7	Quantity
Ar	Ar	Argon
C1	C1	Carbon 1 equivalent hydrocarbon
CH <sub>4</sub>	CH <sub>4</sub>	Methane
C <sub>2</sub> H <sub>6</sub>	C <sub>2</sub> H <sub>6</sub>	Ethane
C <sub>3</sub> H <sub>8</sub>	C <sub>3</sub> H <sub>8</sub>	Propane
CO	CO	Carbon monoxide
CO <sub>2</sub>	CO <sub>2</sub>	Carbon dioxide
DOP	DOP	Di-octylphthalate
HC	HC	Hydrocarbon
H <sub>2</sub> O	H <sub>2</sub> O	Water
NMHC	NMHC	Non-methane hydrocarbon
NO <sub>x</sub>	NO <sub>x</sub>	Oxides of nitrogen
NO	NO	Nitric oxide
NO <sub>2</sub>	NO <sub>2</sub>	Nitrogen dioxide
PM	PM	Particulate matter
S	S	Sulfur

## A.8.0.4. Symbols and abbreviations for the fuel composition

Annex 8 <sup>(1)</sup>	Annex 7 <sup>(2)</sup>	Quantity
$w_C^{(4)}$	$w_C^{(4)}$	Carbon content of fuel, mass fraction [g/g] or [per cent mass]
$w_H$	$w_H$	Hydrogen content of fuel, mass fraction [g/g] or [per cent mass]
$w_N$	$w_N$	Nitrogen content of fuel, mass fraction [g/g] or [per cent mass]
$w_O$	$w_O$	Oxygen content of fuel, mass fraction [g/g] or [per cent mass]
$w_S$	$w_S$	Sulphur content of fuel, mass fraction [g/g] or [per cent mass]
$\alpha$	$\alpha$	Atomic hydrogen-to-carbon ratio (H/C)
$\varepsilon$	$\beta$	Atomic oxygen-to-carbon ratio (O/C) <sup>(3)</sup>
$\gamma$	$\gamma$	Atomic sulphur-to-carbon ratio (S/C)
$\delta$	$\delta$	Atomic nitrogen-to-carbon ratio (N/C)

- (1) Referred to a fuel with chemical formula  $CH_\alpha O_\varepsilon N_\delta S_\gamma$   
(2) Referred to a fuel with chemical formula  $CH_\alpha O_\beta S_\gamma N_\delta$   
(3) Attention should be paid to the different meaning of symbol  $\beta$  in the two emissions calculation annexes: in Annex 8 it refers to a fuel having the chemical formula  $CH_\alpha S_\gamma N_\delta O_\varepsilon$  (i.e. the formula  $C_\beta H_\alpha S_\gamma N_\delta O_\varepsilon$  where  $\beta = 1$ , assuming one carbon atom per molecule), while in Annex 7 it refers to the oxygen-to-carbon ratio with  $CH_\alpha O_\beta S_\gamma N_\delta$ . Then  $\beta$  of Annex 7 corresponds to  $\varepsilon$  of Annex 8.  
(4) Mass fraction  $w$  accompanied by the symbol of the chemical component as a subscript.

A.8.1. Basic Parameters

## A.8.1.1. Determination of methane and non-methane HC concentration

The concentration of NMHC ( $c_{\text{NMHC}}$  [-]) and CH<sub>4</sub> ( $c_{\text{CH}_4}$  [-]) shall be calculated as follows:

$$c_{\text{NMHC}} = \frac{c_{\text{HC(w/oCutter)}} \cdot (1 - E_{\text{CH}_4}) - c_{\text{HC(w/Cutter)}}}{E_{\text{C}_2\text{H}_6} - E_{\text{CH}_4}} \quad (\text{A.8-1})$$

$$c_{\text{CH}_4} = \frac{c_{\text{HC(w/Cutter)}} - c_{\text{HC(w/oCutter)}} \cdot (1 - E_{\text{C}_2\text{H}_6})}{E_{\text{C}_2\text{H}_6} - E_{\text{CH}_4}} \quad (\text{A.8-2})$$

Where:

$c_{\text{HC(w/Cutter)}}$  = HC concentration with sample gas flowing through the NMC [ppm]

$c_{\text{HC(w/oCutter)}}$  = HC concentration with sample gas bypassing the NMC [ppm]

$E_{\text{CH}_4}$  = methane efficiency, as determined in paragraph 8.1.10.3. [-]

$E_{\text{C}_2\text{H}_6}$  = the ethane efficiency, as determined in paragraph 8.1.10.3. [-]

NMHC (non-methane hydrocarbon) emissions can be approximated as 98 percent of THC (total hydrocarbon).

A.8.2. Raw gaseous emissions

## A.8.2.1. Gaseous emissions

## A.8.2.1.1. Steady state tests

The emission rate of a gaseous emission  $q_{\text{mgas},i}$  for each mode  $i$  of the steady state test shall be calculated. The concentration of the gaseous emission shall be multiplied by its respective flow:

$$q_{\text{mgas},i} = k_h \cdot k \cdot u_{\text{gas}} \cdot q_{\text{mew},i} \cdot c_{\text{gas},i} \cdot \frac{3600}{1000} \quad (\text{A.8-3})$$

$q_{\text{mgas},i}$  = emission rate in mode  $i$  of the steady state test [g/h]

$k$  = 1 for  $c_{\text{gasr},w,i}$  in [ppm] and  $k = 10,000$  for  $c_{\text{gasr},w,i}$  in [per cent vol]

$k_h$  = NO<sub>x</sub> correction factor [-], only to be applied for the NO<sub>x</sub> emission calculation (see paragraph A.8.2.2.)

$u_{\text{gas}}$  = component specific factor or ratio between densities of gas component and exhaust gas (see paragraph A.8.2.4.)

$q_{\text{mew},i}$  = exhaust gas mass flow rate in mode  $i$  on a wet basis [kg/s]

$c_{\text{gas},i}$  = emission concentration in the raw exhaust gas in mode  $i$ , on a wet basis [ppm] or [per cent vol]

## A.8.2.1.2. Transient and ramped modal cycles tests

The total mass per test of a gaseous emission  $m_{\text{gas}}$  [g/test] shall be calculated by multiplication of the time aligned instantaneous concentrations and exhaust gas flows and integration over the test cycle according to the following equation:

$$m_{\text{gas}} = \frac{1}{f} \cdot k_h \cdot k \cdot u_{\text{gas}} \cdot \sum_{i=1}^N (q_{\text{mew},i} \cdot c_{\text{gas},i}) \quad (\text{A.8-4})$$

Where:

$f$	=	data sampling rate [Hz]
$k_h$	=	NO <sub>x</sub> correction factor [-], only to be applied for the NO <sub>x</sub> emission calculation
$k$	=	1 for $c_{\text{gasr},w,i}$ in [ppm] and $k = 10,000$ for $c_{\text{gasr},w,i}$ in [per cent vol]
$u_{\text{gas}}$	=	component specific factor (see paragraph A.8.2.4.)
$N$	=	number of measurements [-]
$q_{\text{mew},i}$	=	instantaneous exhaust gas mass flow rate on a wet basis [kg/s]
$c_{\text{gas},i}$	=	instantaneous emission concentration in the raw exhaust gas, on a wet basis [ppm] or [per cent vol]

The following chapters show how the needed quantities ( $c_{\text{gas},i}$ ,  $u_{\text{gas}}$  and  $q_{\text{mew},i}$ ) shall be calculated.

## A.8.2.2. Dry-to wet concentration conversion

If the emissions are measured on a dry basis, the measured concentration  $c_d$  on dry basis shall be converted to the concentration  $c_w$  on a wet basis according to the following general equation:

$$c_w = k_w \cdot c_d \quad (\text{A.8-5})$$

Where:

$k_w$	=	dry-to-wet conversion factor [-]
$c_d$	=	emission concentration on a dry basis [ppm] or [per cent vol]

For complete combustion, the dry-to-wet conversion factor for raw exhaust gas is written as  $k_{w,a}$  [-] and shall be calculated as follows:

$$k_{w,a} = \frac{\left( 1 - \frac{1.2442 \cdot H_a + 111.19 \cdot w_H \cdot \frac{q_{mf,i}}{q_{mad,i}}}{773.4 + 1.2442 \cdot H_a + \frac{q_{mf,i}}{q_{mad,i}} \cdot k_f \cdot 1000} \right)}{\left( 1 - \frac{p_r}{p_b} \right)} \quad (\text{A.8-6})$$

Where:

$H_a$	=	intake air humidity [g H <sub>2</sub> O/kg dry air] (see paragraph A.8.1.2.)
$q_{mf,i}$	=	instantaneous fuel flow rate [kg/s]
$q_{mad,i}$	=	instantaneous dry intake air flow rate [kg/s]
$p_r$	=	water pressure after cooler [kPa]
$p_b$	=	total barometric pressure [kPa]
$w_H$	=	hydrogen content of the fuel [per cent mass]
$k_f$	=	combustion additional volume [m <sup>3</sup> /kg fuel]

with:

$$k_f = 0.055594 \cdot w_H + 0.0080021 \cdot w_N + 0.0070046 \cdot w_O \quad (\text{A.8-7})$$

Where:

$w_H$	=	hydrogen content of fuel [per cent mass]
$w_N$	=	nitrogen content of fuel [per cent mass]
$w_O$	=	oxygen content of fuel [per cent mass]

In the equation (A.8-6), the ratio  $p_r/p_b$  may be assumed:

$$\frac{1}{\left( 1 - \frac{p_r}{p_b} \right)} = 1.008 \quad (\text{A.8-8})$$

For incomplete combustion (rich fuel air mixtures) and also for emission tests without direct air flow measurements, a second method of  $k_{w,a}$  calculation is preferred:

$$k_{w,a} = \frac{1}{1 + \alpha \cdot 0.005 \cdot (c_{CO_2} + c_{CO})} - k_{w1} \quad (\text{A.8-9})$$

$$\frac{1}{1 - \frac{p_r}{p_b}}$$

Where:

$c_{CO_2}$ =	concentration of CO <sub>2</sub> in the raw exhaust gas, on a dry basis [per cent vol]
$c_{CO}$ =	concentration of CO in the raw exhaust gas, on a dry basis [ppm]
$p_r$ =	water pressure after cooler [kPa] (see equation (A.8-9))
$p_b$ =	total barometric pressure [kPa] (see equation (A.8-9))
$\alpha$ =	molar to carbon hydrogen ratio [-]
$k_{w1}$ =	intake air moisture [-]

$$k_{w1} = \frac{1.608 \cdot H_a}{1000 + 1.608 \cdot H_a} \quad (\text{A.8-10})$$

#### A.8.2.3. NO<sub>x</sub> correction for humidity and temperature

As the NO<sub>x</sub> emission depends on ambient air conditions, the NO<sub>x</sub> concentration shall be corrected for ambient air temperature and humidity with the factors  $k_h$  [-] given in the following equation. This factor is valid for a humidity range between 0 and 25 g<sub>H2O</sub>/kg dry air.

$$k_h = \frac{15.698 \cdot H_a}{1000} + 0.832 \quad (\text{A.8-11})$$

Where:

$H_a$  = humidity of the intake air [g H<sub>2</sub>O/kg dry air]

#### A.8.2.4. Component specific factor $u$

##### A.8.2.4.1. Tabulated values

Applying some simplifications (assumption on the  $\lambda$  value and on intake air conditions as shown in the following table) to the equations of paragraph A.8.2.4.2. figures for  $u_{gas}$ , can be calculated (see paragraph A.8.2.1.). The  $u_{gas}$  values are given in table A.8.1.

Gas	NO <sub>x</sub>	CO	HC	CO <sub>2</sub>	O <sub>2</sub>	CH <sub>4</sub>	
$\rho_{gas}$ [kg/m <sup>3</sup> ]	2.053	1.250	0.621	1.9636	1.4277	0.716	
FUEL	$\rho_c$ Coefficient $u_{gas}$ at $\lambda = 2$ , dry air, 273 K, 101.3 kPa						
Diesel	1.2939	0.001587	0.000966	0.000479	0.001518	0.001103	0.000553

Table A.8.1 – Raw exhaust gas  $u$  and component densities (the  $u$  figures are calculated for emission concentration expressed in ppm).

## A.8.2.4.2. Calculated values

The component specific factor,  $u_{\text{gas},i}$ , can be calculated by the density ratio of the component and the exhaust or alternatively by the corresponding ratio of molar masses:

$$u_{\text{gas},i} = M_{\text{gas}} / (M_{e,i} \cdot 1000) \quad (\text{A.8-12})$$

or

$$u_{\text{gas},i} = \rho_{\text{gas}} / (\rho_{e,i} \cdot 1000) \quad (\text{A.8-13})$$

Where:

- $M_{\text{gas}}$  = molar mass of the gas component [g/mol]
- $M_{e,i}$  = instantaneous molar mass of the wet raw exhaust gas [g/mol]
- $\rho_{\text{gas}}$  = density of the gas component [kg/m<sup>3</sup>]
- $\rho_{e,i}$  = instantaneous density of the wet raw exhaust gas [kg/m<sup>3</sup>]

The molar mass of the exhaust,  $M_{e,i}$  shall be derived for a general fuel composition  $\text{CH}_\alpha\text{O}_\varepsilon\text{N}_\delta\text{S}_\gamma$  under the assumption of complete combustion, as follows:

$$M_{e,i} = \frac{1 + \frac{q_{mf,i}}{q_{maw,i}}}{\frac{q_{mf,i}}{q_{maw,i}} \cdot \frac{\frac{\alpha}{4} + \frac{\varepsilon}{2} + \frac{\delta}{2}}{12.001 + 1.00794 \cdot \alpha + 15.9994 \cdot \varepsilon + 14.0067 \cdot \delta + 32.0065 \cdot \gamma} + \frac{\frac{H_a \cdot 10^{-3}}{2 \times 1.00794 + 15.9994} + \frac{1}{M_a}}{1 + H_a \cdot 10^{-3}}} \quad (\text{A.8-14})$$

Where:

- $q_{mf,i}$  = instantaneous fuel mass flow rate on wet basis [kg/s]
- $q_{maw,i}$  = instantaneous intake air mass flow rate on wet basis [kg/s]
- $\alpha$  = molar hydrogen-to-carbon ratio [-]
- $\delta$  = molar sulphur-to-carbon ratio [-]
- $\varepsilon$  = molar oxygen-to-carbon ratio [-]
- $H_a$  = intake air humidity [g H<sub>2</sub>O/kg dry air]
- $M_a$  = dry intake air molecular mass = 28.965 g/mol

The instantaneous raw exhaust density  $\rho_{e,i}$  [kg/m<sup>3</sup>] shall be derived as follows:

$$\rho_{e,i} = \frac{1000 + H_a + 1000 \cdot (q_{mf,i} / q_{mad,i})}{773.4 + 1.2434 \cdot H_a + k_f \cdot 1000 \cdot (q_{mf,i} / q_{mad,i})} \quad (\text{A.8-15})$$



Where:

$q_{mf,i}$ =	instantaneous fuel mass flow rate [kg/s]
$q_{mad,i}$ =	instantaneous dry intake air mass flow rate [kg/s]
$H_a$ =	intake air humidity [g H <sub>2</sub> O/kg dry air]
$k_f$ =	combustion additional volume [m <sup>3</sup> /kg fuel] (see equation A.8-7)

#### A.8.2.5. Mass flow rate of the exhaust gas

##### A.8.2.5.1. Air and fuel measurement method

The method involves measurement of the air flow and the fuel flow with suitable flowmeters. The calculation of the instantaneous exhaust gas flow  $q_{mew,i}$  [kg/s] shall be as follows:

$$q_{mew,i} = q_{maw,i} + q_{mf,i} \quad (\text{A.8-16})$$

Where:

$q_{maw,i}$ =	instantaneous intake air mass flow rate [kg/s]
$q_{mf,i}$ =	instantaneous fuel mass flow rate [kg/s]

##### A.8.2.5.2. Tracer measurement method

This involves measurement of the concentration of a tracer gas in the exhaust. The calculation of the instantaneous exhaust gas flow  $q_{mew,i}$  [kg/s] shall be as follows:

$$q_{mew,i} = \frac{q_{Vt} \cdot \rho_e}{10^{-6} \cdot (c_{mix,i} - c_b)} \quad (\text{A.8-17})$$

Where:

$q_{Vt}$ =	tracer gas flow rate [m <sup>3</sup> /s]
$c_{mix,i}$ =	instantaneous concentration of the tracer gas after mixing [ppm]
$\rho_e$ =	density of the raw exhaust gas [kg/m <sup>3</sup> ]
$c_b$ =	background concentration of the tracer gas in the intake air [ppm]

The background concentration of the tracer gas  $c_b$  may be determined by averaging the background concentration measured immediately before the test run and after the test run. When the background concentration is less than 1 per cent of the concentration of the tracer gas after mixing  $c_{mix,i}$  at maximum exhaust flow, the background concentration may be neglected.

##### A.8.2.5.3. Air flow and air to fuel ratio measurement method

This involves exhaust mass calculation from the air flow and the air to fuel ratio. The calculation of the instantaneous exhaust gas mass flow  $q_{mew,i}$  [kg/s] is as follows:

$$q_{mew,i} = q_{maw,i} \cdot \left( 1 + \frac{1}{A/F_{st} \cdot \lambda_i} \right) \quad (\text{A.8-18})$$

with:

$$A/F_{st} = \frac{138.0 \cdot \left( 1 + \frac{\alpha}{4} - \frac{\varepsilon}{2} + \gamma \right)}{12.011 + 1.00794 \cdot \alpha + 15.9994 \cdot \varepsilon + 14.0067 \cdot \delta + 32.065 \cdot \gamma} \quad (\text{A.8-19})$$

$$\lambda_i = \frac{\left( 100 - \frac{c_{COd} \cdot 10^{-4}}{2} - c_{HCw} \cdot 10^{-4} \right) + \left( \frac{\alpha}{4} \cdot \frac{1 - \frac{2 \cdot c_{COd} \cdot 10^{-4}}{3.5 \cdot c_{CO2d}}}{1 + \frac{c_{COd} \cdot 10^{-4}}{3.5 \cdot c_{CO2d}}} - \frac{\varepsilon}{2} - \frac{\delta}{2} \right) \cdot (c_{CO2d} + c_{COd} \cdot 10^{-4})}{4.764 \cdot \left( 1 + \frac{\alpha}{4} - \frac{\varepsilon}{2} + \gamma \right) \cdot (c_{CO2d} + c_{COd} \cdot 10^{-4} + c_{HCw} \cdot 10^{-4})} \quad (\text{A.8-20})$$

Where:

$q_{maw,i}$	wet intake air mass flow rate [kg/s]
$A/F_{st}$	stoichiometric air-to-fuel ratio [-]
$\lambda_i$	instantaneous excess air ratio [-]
$c_{COd}$	concentration of CO in the raw exhaust gas on a dry basis [ppm]
$c_{CO2d}$	concentration of CO <sub>2</sub> in the raw exhaust gas on a dry basis [per cent]
$c_{HCw}$	concentration of HC in the raw exhaust gas on a wet basis [ppm C1]
$\alpha$	molar hydrogen-to-carbon ratio [-]
$\delta$	molar sulphur-to-carbon ratio [-]
$\varepsilon$	molar oxygen-to-carbon ratio [-]
$\gamma$	molar nitrogen-to-carbon ratio [-]

#### A.8.2.5.4. Carbon balance method, 1 step-procedure

The following 1-step formula can be used for the calculation of the wet exhaust mass flow rate  $q_{mew,i}$  [kg/s]:

$$q_{mew,i} = q_{mf,i} \cdot \left[ \frac{1.4 \cdot w_C^2}{(1.0828 \cdot w_C + k_{fd} \cdot f_c) f_c} \left( 1 + \frac{H_a}{1000} \right) + 1 \right] \quad (\text{A.8-21})$$

with the carbon factor  $f_c$  [-] given by:

$$f_c = 0.5441 \cdot (c_{CO2d} - c_{CO2d}) + \frac{c_{COd}}{18,522} + \frac{c_{HCw}}{17,355} \quad (\text{A.8-22})$$

Where:

$q_{mf,i}$	instantaneous fuel mass flow rate [kg/s]
------------	--

$w_C$ =	carbon content of fuel [per cent mass]
$H_a$ =	intake air humidity [g H <sub>2</sub> O/kg dry air]
$k_{fd}$ =	combustion additional volume on a dry basis [m <sup>3</sup> /kg fuel]
$c_{CO2d}$ =	dry CO <sub>2</sub> concentration in the raw exhaust [per cent]
$c_{CO2ad}$ =	dry CO <sub>2</sub> concentration in the ambient air [per cent]
$c_{COd}$ =	dry CO concentration in the raw exhaust [ppm]
$c_{HCw}$ =	wet HC concentration in the raw exhaust [ppm]

and factor  $k_{fd}$  [m<sup>3</sup>/kg fuel] that is calculated on a dry basis by subtracting the water formed by combustion from  $k_f$ :

$$k_{fd} = k_f - 0.11118 \cdot w_H \quad (\text{A.8-23})$$

Where:

$k_f$ =	fuel specific factor of equation (A.8-7) [m <sup>3</sup> /kg fuel]
$w_H$ =	hydrogen content of fuel [per cent mass]

### A.8.3. Diluted gaseous emissions

#### A.8.3.1. Mass of the gaseous emissions

##### A.8.3.1.1. Full flow dilution measurement (CVS)

The exhaust mass flow rate shall be measured with a constant volume sampling (CVS) system, which may use a positive displacement pump (PDP), a critical flow venturi (CFV) or a subsonic venturi (SSV).

For systems with constant mass flow (i.e. with heat exchanger), the mass of the pollutants  $m_{gas}$  [g/test] shall be determined from the following equation:

$$m_{gas} = k_h \cdot k \cdot u_{gas} \cdot c_{gas} \cdot m_{ed} \quad (\text{A.8-24})$$

Where:

$u_{gas}$ =	ratio between density of exhaust component and density of air (tabulated values) [-]
$c_{gas}$ =	mean background corrected concentration of the component on a wet basis [ppm] or [per cent vol] respectively
$k_h$ =	NO <sub>x</sub> correction factor [-], only to be applied for the NO <sub>x</sub> emission calculation
$k$ =	1 for $c_{gasr,w,i}$ in [ppm], $k = 10,000$ for $c_{gasr,w,i}$ in [per cent vol]
$m_{ed}$ =	total diluted exhaust gas mass over the cycle [kg/test]

For systems with flow compensation (without heat exchanger), the mass of the pollutants  $m_{gas}$  [g/test] shall be determined by calculation of the instantaneous mass

emissions, by integration and by background correction according to the following equation:

$$m_{\text{gas}} = k_h \cdot k \cdot \left\{ \sum_{i=1}^N \left[ (m_{\text{ed},i} \cdot c_e \cdot u_{\text{gas}}) \right] - \left[ \left( m_{\text{ed}} \cdot c_d \cdot \left( 1 - \frac{1}{D} \right) \cdot u_{\text{gas}} \right) \right] \right\} \quad (\text{A.8-25})$$

Where:

- $c_e$  = emission concentration in the diluted exhaust gas, on a wet basis [ppm] or [per cent vol]  
 $c_d$  = emission concentration in the dilution air, on a wet basis [ppm] or [per cent vol]  
 $m_{\text{ed},i}$  = mass of the diluted exhaust gas during time interval  $i$  [kg]  
 $m_{\text{ed}}$  = total mass of diluted exhaust gas over the cycle [kg]  
 $u_{\text{gas}}$  = tabulated value from table A.8.2 [-]  
 $D$  = dilution factor (see equation (A.8-29) of paragraph A.8.3.2.2.) [-]  
 $k_h$  = NO<sub>x</sub> correction factor [-], only to be applied for the NO<sub>x</sub> emission calculation  
 $k$  = 1 for  $c$  in [ppm],  $k = 10,000$  for  $c$  in [per cent vol]

The concentrations  $c_{\text{gas}}$ ,  $c_e$  and  $c_d$  can be either values measured in a batch sample (bag, but not allowed for NO<sub>x</sub> and HC) or be averaged by integration from continuous measurements. Also  $m_{\text{ed},i}$  has to be averaged by integration over the test cycle.

The following equations show how the needed quantities ( $c_e$ ,  $u_{\text{gas}}$  and  $m_{\text{ed}}$ ) shall be calculated.

#### A.8.3.2. Dry-to wet concentration conversion

All concentrations in section A.8.3.2. shall be converted using equation (A.8-5) ( $c_w = k_w \cdot c_d$ ).

##### A.8.3.2.1. Diluted exhaust gas

All concentrations measured dry shall be converted to wet concentrations by one of the following two equations applied to equation:

$$k_{w,c} = \left[ \left( 1 - \frac{\alpha \cdot c_{\text{CO2w}}}{200} \right) - k_{w2} \right] \cdot 1.008 \quad (\text{A.8-26})$$

or

$$k_{w,e} = \left( \frac{(1 - k_{w2})}{1 + \frac{\alpha \cdot c_{CO2d}}{200}} \right) \cdot 1.008 \quad (\text{A.8-27})$$

Where:

$k_{w,e}$  = dry-to-wet conversion factor for the diluted exhaust gas [-]

$\alpha$  = molar hydrogen to carbon ratio of the fuel [-]

$c_{CO2w}$  = concentration of CO<sub>2</sub> in the diluted exhaust gas on a wet basis [per cent vol]

$c_{CO2d}$  = concentration of CO<sub>2</sub> in the diluted exhaust gas on a dry basis [per cent vol]

The dry to wet correction factor  $k_{w2}$  takes into consideration the water content of both intake air and dilution air:

$$k_{w2} = \frac{1.608 \cdot \left[ H_d \cdot \left( 1 - \frac{1}{D} \right) + H_a \cdot \left( \frac{1}{D} \right) \right]}{1000 + \left\{ 1.608 \cdot \left[ H_d \cdot \left( 1 - \frac{1}{D} \right) + H_a \cdot \left( \frac{1}{D} \right) \right] \right\}} \quad (\text{A.8-28})$$

Where:

$H_a$  = intake air humidity [g H<sub>2</sub>O/kg dry air]

$H_d$  = dilution air humidity [g H<sub>2</sub>O/kg dry air]

$D$  = dilution factor (see equation (A.8-29) of paragraph A.8.3.2.2.) [-]

#### A.8.3.2.2. Dilution factor

The dilution factor  $D$  [-] (which is necessary for the background correction and the  $k_{w2}$  calculation) shall be calculated as follows:

$$D = \frac{F_S}{c_{CO2,e} + (c_{HC,e} + c_{CO,e}) \cdot 10^{-4}} \quad (\text{A.8-29})$$

Where:

$F_S$  = stoichiometric factor [-]

$c_{CO2,e}$  = concentration of CO<sub>2</sub> in the diluted exhaust gas on a wet basis [per cent vol]

$c_{HC,e}$  = concentration of HC in the diluted exhaust gas on a wet basis [ppm C1]

$c_{CO,e}$  = concentration of CO in the diluted exhaust gas on a wet basis [ppm]

The stoichiometric factor shall be calculated as follows:

$$F_S = 100 \cdot \frac{1}{1 + \frac{\alpha}{2} + 3.76 \cdot \left( 1 + \frac{\alpha}{4} \right)} \quad (\text{A.8-30})$$

Where:

$\alpha =$  molar hydrogen to carbon ratio in the fuel [-]

Alternatively, if the fuel composition is not known, the following stoichiometric factors may be used:  $F_S$  (diesel) = 13.4

If a direct measurement is made of the exhaust gas flow, the dilution factor  $D$  [-] may be calculated as follows:

$$D = \frac{q_{VCVS}}{q_{Vew}} \quad (\text{A.8-31})$$

Where:

$q_{VCVS}$  is the volumetric flow rate of diluted exhaust gas [ $\text{m}^3/\text{s}$ ]

$q_{Vew}$  = volumetric flow rate of raw exhaust gas [ $\text{m}^3/\text{s}$ ]

#### A.8.3.2.3. Dilution air

$$k_{w,d} = (1 - k_{w3}) \cdot 1.008 \quad (\text{A.8-32})$$

with

$$k_{w3} = \frac{1.608 \cdot H_d}{1000 + 1.608 \cdot H_d} \quad (\text{A.8-33})$$

Where:

$H_d =$  dilution air humidity [ $\text{g H}_2\text{O}/\text{kg dry air}$ ]

#### A.8.3.2.4. Determination of the background corrected concentration

The average background concentration of the gaseous pollutants in the dilution air shall be subtracted from measured concentrations to get the net concentrations of the pollutants. The average values of the background concentrations can be determined by the sample bag method or by continuous measurement with integration. The following equation shall be used:

$$c_{\text{gas}} = c_{\text{gas,e}} - c_d \cdot \left(1 - \frac{1}{D}\right) \quad (\text{A.8-34})$$

Where:

$c_{\text{gas}} =$  net concentration of the gaseous pollutant [ppm] or [per cent vol]

- $c_{\text{gas,e}}$  = emission concentration in the diluted exhaust gas, on a wet basis [ppm] or [per cent vol]  
 $c_{\text{d}}$  = emission concentration in the dilution air, on a wet basis [ppm] or [per cent vol]  
 $D$  = dilution factor (see equation (A.8-29) of paragraph A.8.3.2.2.) [-]

### A.8.3.3. Component specific factor $u$

The component specific factor  $u_{\text{gas}}$  of diluted gas can either be calculated by the following equation or be taken from table A.8.2; in table A.8.2 the density of the diluted exhaust gas has been assumed equal to air density.

$$u = \frac{M_{\text{gas}}}{M_{\text{d,w}}} = \frac{M_{\text{gas}}}{M_{\text{da,w}} \cdot \left(1 - \frac{1}{D}\right) + M_{\text{r,w}} \cdot \left(\frac{1}{D}\right)} \quad (\text{A.8-35})$$

Where:

- $M_{\text{gas}}$  = molar mass of the gas component [g/mol]  
 $M_{\text{d,w}}$  = molar mass of diluted exhaust gas [g/mol]  
 $M_{\text{da,w}}$  = molar mass of dilution air [g/mol]  
 $M_{\text{r,w}}$  = molar mass of raw exhaust gas [g/mol]  
 $D$  = dilution factor (see equation (A.8-29) of paragraph A.8.3.2.2.) [-]

Fuel	$\rho_{\text{de}}$	Gas					
		NO <sub>x</sub>	CO	HC	CO <sub>2</sub>	O <sub>2</sub>	CH <sub>4</sub>
		$\rho_{\text{gas}}$ [kg/m <sup>3</sup> ]					
		2.053	1.250	0.621	1.9636	1.4277	0.716
		Coefficient $u_{\text{gas}}$ at $\lambda = 2$ , dry air, 273 K, 101.3 kPa					
Diesel	1.293	0.001588	0.000967	0.000480	0.001519	0.001104	0.000553

Table A.8.2 – Diluted exhaust gas  $u$  values and component densities (the  $u$  figures are calculated for emission concentration expressed in ppm)

### A.8.3.4. Exhaust gas mass flow calculation

#### A.8.3.4.1. PDP-CVS system

The calculation of the mass of the diluted exhaust [kg/test] over the cycle is as follows, if the temperature of the diluted exhaust  $m_{\text{ed}}$  is kept within  $\pm 6$  K over the cycle by using a heat exchanger:

$$m_{\text{ed}} = 1.293 \cdot V_0 \cdot n_p \cdot \frac{p_p}{101.3} \cdot \frac{273}{T} \quad (\text{A.8-36})$$

Where:

- $V_0$  = volume of gas pumped per revolution under test conditions [m<sup>3</sup>/rev]  
 $n_p$  = total revolutions of pump per test [rev/test]

$p_p$  = absolute pressure at pump inlet [kPa]  
 $T$  = average temperature of the diluted exhaust gas at pump inlet [K]  
 $1.293$  = air density [ $\text{kg}/\text{m}^3$ ] at 273.15 K and 101.325 kPa

If a system with flow compensation is used (i.e. without heat exchanger), the mass of the diluted exhaust gas  $m_{\text{ed},i}$  [kg] during the time interval shall be calculated as follows:

$$m_{\text{ed},i} = 1.293 \cdot V_0 \cdot n_{p,i} \cdot \frac{p_p}{101.3} \cdot \frac{273}{T} \quad (\text{A.8-37})$$

Where:

$V_0$  = volume of gas pumped per revolution under test conditions [ $\text{m}^3/\text{rev}$ ]  
 $p_p$  = absolute pressure at pump inlet [kPa]  
 $n_{p,i}$  = total revolutions of pump per time interval  $i$  [ $\text{rev}/\Delta t$ ]  
 $\bar{T}$  = average temperature of the diluted exhaust gas at pump inlet [K]  
 $1.293$  = air density [ $\text{kg}/\text{m}^3$ ] at 273.15 K and 101.325 kPa

#### A.8.3.4.2. CFV-CVS system

The calculation of the mass flow over the cycle  $m_{\text{ed}}$  [g/test] is as follows, if the temperature of the diluted exhaust is kept within  $\pm 11$  K over the cycle by using a heat exchanger:

$$m_{\text{ed}} = \frac{1.293 \cdot t \cdot K_v \cdot p_p}{T^{0.5}} \quad (\text{A.8-38})$$

Where:

$t$  = cycle time [s]  
 $K_v$  = calibration coefficient of the critical flow venturi for standard conditions  
 $\left[ \left( \sqrt{\text{K}} \cdot \text{m}^4 \cdot \text{s} \right) / \text{kg} \right]$   
 $p_p$  = absolute pressure at venturi inlet [kPa]  
 $T$  = absolute temperature at venturi inlet [K]  
 $1.293$  = air density [ $\text{kg}/\text{m}^3$ ] at 273.15 K and 101.325 kPa

If a system with flow compensation is used (i.e. without heat exchanger), the mass of the diluted exhaust gas  $m_{\text{ed},i}$  [kg] during the time interval shall be calculated as follows:

$$m_{\text{ed},i} = \frac{1.293 \cdot \Delta t_i \cdot K_v \cdot p_p}{T^{0.5}} \quad (\text{A.8-39})$$

Where:

$\Delta t_i$  = time interval of the test [s]



$K_V =$	calibration coefficient of the critical flow venturi for standard conditions $\left[ \left( \sqrt{\text{K}} \cdot \text{m}^4 \cdot \text{s} \right) / \text{kg} \right]$
$p_P =$	absolute pressure at venturi inlet [kPa]
$T =$	absolute temperature at venturi inlet [K]
1.293 =	air density [ $\text{kg}/\text{m}^3$ ] at 273.15 K and 101.325 kPa

#### A.8.3.4.3. SSV-CVS system

The calculation of the diluted exhaust gas mass over the cycle  $m_{ed}$  [kg/test] shall be as follows, if the temperature of the diluted exhaust is kept within  $\pm 11\text{K}$  over the cycle by using a heat exchanger:

$$m_{ed} = 1.293 \cdot q_{SSV} \cdot \Delta t \quad (\text{A.8-40})$$

Where:

1.293 $\text{kg}/\text{m}^3 =$	air density at 273.15 K and 101.325 kPa
$\Delta t =$	cycle time [s]

with

$$q_{SSV} = A_0 d_v^2 C_d p_P \sqrt{\left[ \frac{1}{T} \left( r_p^{1,4286} - r_p^{1,7143} \right) \cdot \left( \frac{1}{1 - r_D^4 r_p^{1,4286}} \right) \right]} \quad (\text{A.8-41})$$

Where:

$$A_0 = 0.0056940 \text{ collection constant for } \left[ \frac{\text{m}^3}{\text{min}} \cdot \frac{\text{K}^{\frac{1}{2}}}{\text{kPa}} \cdot \frac{1}{\text{mm}^2} \right]$$

$d_v =$  diameter of the SSV throat [m]

$C_d =$  discharge coefficient of the SSV [-]

$p_{in} =$  absolute pressure at venturi inlet [kPa]

$T_{in} =$  temperature at the venturi inlet [K]

$r_p =$  ratio of the SSV throat to inlet absolute static pressure,  $\left( 1 - \frac{\Delta p}{p_a} \right)$  [-]

$r_D =$  ratio of the SSV throat diameter to the inlet pipe inner diameter  $\frac{d}{D}$  [-]

If a system with flow compensation is used (i.e. without heat exchanger), the mass of the diluted exhaust gas  $m_{ed,i}$  [kg] during the time interval shall be calculated as follows:

$$m_{ed,i} = 1.293 \cdot q_{SSV} \cdot \Delta t_i \quad (\text{A.8-42})$$

Where:

$1.293 \text{ kg/m}^3 =$  air density at 273.15 K and 101.325 kPa

$\Delta t_i =$  time interval [s]

$q_{SSV} =$  volumetric flow rate of the SSV [ $\text{m}^3/\text{s}$ ]

#### A.8.3.5. Calculation of particulates emission

##### A.8.3.5.1. Transient and ramped modal cycles

The particulate mass shall be calculated after buoyancy correction of the particulate sample mass according to paragraph 8.1.12.2.5.

##### A.8.3.5.1.1. Partial flow dilution system

The calculation for double dilution system is shown in paragraph A.8.3.5.1.2.

##### A.8.3.5.1.1.1. Calculation based on sample ratio

The particulate emission over the cycle  $m_{PM}$  [g] shall be calculated with the following equation:

$$m_{PM} = \frac{m_f}{r_s \cdot 1000} \quad (\text{A.8-43})$$

Where:

$m_f =$  particulate mass sampled over the cycle [mg]

$r_s =$  average sample ratio over the test cycle [-]

with:

$$r_s = \frac{m_{sc}}{m_{ew}} \cdot \frac{m_{sep}}{m_{sed}} \quad (\text{A.8-44})$$

Where:

$m_{sc} =$  sample mass of raw exhaust over the cycle [kg]

$m_{ew} =$  total mass of raw exhaust over the cycle [kg]

$m_{sep} =$  mass of diluted exhaust gas passing the particulate collection filters [kg]

$m_{sed} =$  mass of diluted exhaust gas passing the dilution tunnel [kg]

In case of the total sampling type system,  $m_{sep}$  and  $m_{sed}$  are identical.

## A.8.3.5.1.1.2. Calculation based on dilution ratio

The particulate emission over the cycle  $m_{PM}$  [g] shall be calculated with the following equation:

$$m_{PM} = \frac{m_f}{m_{sep}} \cdot \frac{m_{edf}}{1000} \quad (\text{A.8-45})$$

Where:

$m_f$  = particulate mass sampled over the cycle [mg]  
 $m_{sep}$  = mass of diluted exhaust gas passing the particulate collection filters [kg]  
 $m_{edf}$  = mass of equivalent diluted exhaust gas over the cycle [kg]

The total mass of equivalent diluted exhaust gas mass over the cycle  $m_{edf}$  [kg] shall be determined as follows:

$$m_{edf} = \frac{1}{f} \cdot \sum_{i=1}^N q_{medf,i} \quad (\text{A.8-46})$$

$$q_{medf,i} = q_{mew,i} \cdot r_{d,i} \quad (\text{A.8-47})$$

$$r_{d,i} = \frac{q_{mdew,i}}{q_{mdew,i} - q_{mdw,i}} \quad (\text{A.8-48})$$

Where:

$q_{medf,i}$  = instantaneous equivalent diluted exhaust mass flow rate [kg/s]  
 $q_{mew,i}$  = instantaneous exhaust mass flow rate on a wet basis [kg/s]  
 $r_{d,i}$  = instantaneous dilution ratio [-]  
 $q_{mdew,i}$  = instantaneous diluted exhaust mass flow rate on a wet basis [kg/s]  
 $q_{mdw,i}$  = instantaneous dilution air mass flow rate [kg/s]  
 $f$  = data sampling rate [Hz]  
 $n$  = number of measurements [-]

## A.8.3.5.1.2. Full flow dilution system

The mass emission shall be calculated as follows:

$$m_{PM} = \frac{m_f}{m_{sep}} \cdot \frac{m_{ed}}{1000} \quad (\text{A.8-49})$$

Where:

$m_f$  = particulate mass sampled over the cycle [mg]

$m_{\text{sep}}$  = mass of diluted exhaust gas passing the particulate collection filters [kg]  
 $m_{\text{ed}}$  = mass of diluted exhaust gas over the cycle [kg]

with

$$m_{\text{sep}} = m_{\text{set}} - m_{\text{ssd}} \quad (\text{A.8-50})$$

Where:

$m_{\text{set}}$  = mass of double diluted exhaust gas through particulate filter [kg]

$m_{\text{ssd}}$  = mass of secondary dilution air [kg]

#### A.8.3.5.1.3. Background correction

The particulate mass  $m_{\text{PM,c}}$  [g] may be background corrected as follows:

$$m_{\text{PM,c}} = \left\{ \frac{m_f}{m_{\text{sep}}} - \left[ \frac{m_b}{m_{\text{sd}}} \cdot \left( 1 - \frac{1}{D} \right) \right] \right\} \cdot \frac{m_{\text{ed}}}{1000} \quad (\text{A.8-51})$$

Where:

$m_f$  = particulate mass sampled over the cycle [mg]

$m_{\text{sep}}$  = mass of diluted exhaust gas passing the particulate collection filters [kg]

$m_{\text{sd}}$  = mass of dilution air sampled by background particulate sampler [kg]

$m_b$  = mass of collected background particulates of dilution air [mg]

$m_{\text{ed}}$  = mass of equivalent diluted exhaust gas over the cycle [kg]

$D$  = dilution factor (see equation (A.8-29) of paragraph A.8.3.2.2.) [-]

#### A.8.3.5.2. Calculation for steady-state discrete-mode cycles

##### A.8.3.5.2.1. Dilution system

All calculations shall be based upon the average values of the individual modes  $i$  during the sampling period.

- (a) For partial-flow dilution, the equivalent mass flow of diluted exhaust gas shall be determined by means of the system with flow measurement shown in figure 9.2:

$$q_{\text{medf}} = q_{\text{mew}} \cdot r_d \quad (\text{A.8-52})$$

$$r_d = \frac{q_{\text{mdew}}}{q_{\text{mdew}} - q_{\text{mdw}}} \quad (\text{A.8-53})$$

Where:

$q_{medf}$	=	equivalent diluted exhaust mass flow rate [kg/s]
$q_{mew}$	=	exhaust mass flow rate on a wet basis [kg/s]
$r_d$	=	dilution ratio [-]
$q_{mdew}$	=	diluted exhaust mass flow rate on a wet basis [kg/s]
$q_{mdw}$	=	dilution air mass flow rate [kg/s]

(b) For full-flow dilution systems  $q_{mdew}$  is used as  $q_{medf}$ .

#### A.8.3.5.2.2. Calculation of the particulate mass flow rate

The particulate emission flow rate over the cycle  $q_{mPM}$  [g/h] shall be calculated as follows:

(a) For the single-filter method

$$q_{mPM} = \frac{m_f}{m_{sep}} \cdot \overline{q_{medf}} \cdot \frac{3600}{1000} \quad (\text{A.8-54})$$

$$\overline{q_{medf}} = \sum_{i=1}^N q_{medfi} \cdot WF_i \quad (\text{A.8-55})$$

$$m_{sep} = \sum_{i=1}^N m_{sepi} \quad (\text{A.8-56})$$

Where:

$q_{mPM}$	=	particulate mass flow rate [g/h]
$m_f$	=	particulate mass sampled over the cycle [mg]
$\overline{q_{medf}}$	=	average equivalent diluted exhaust gas mass flow rate on wet basis [kg/s]
$q_{medfi}$	=	equivalent diluted exhaust gas mass flow rate on wet basis at mode $i$ [kg/s]
$WF_i$	=	weighting factor for the mode $i$ [-]
$m_{sep}$	=	mass of diluted exhaust gas passing the particulate collection filters [kg]
$m_{sepi}$	=	mass of diluted exhaust sample passed through the particulate sampling filter at mode $i$ [kg]

(b) For the multiple-filter method

$$q_{mPMi} = \frac{m_{fi}}{m_{sepi}} \cdot \overline{q_{medfi}} \cdot \frac{3600}{1000} \quad (\text{A.8-57})$$

Where:

- $q_{mPMi}$  = particulate mass flow rate for the mode  $i$  [g/s]  
 $m_{fi}$  = particulate sample mass collected at mode  $i$  [mg]  
 $q_{medfi}$  = equivalent diluted exhaust gas mass flow rate on wet basis at mode  $i$  [kg/s]  
 $m_{sepi}$  = mass of diluted exhaust sample passed through the particulate sampling filter at mode  $i$  [kg]

The PM mass is determined over the test cycle by summation of the average values of the individual modes  $i$  during the sampling period.

The particulate mass flow rate  $q_{mPM}$  [g/h] may be background corrected as follows:

(c) For the single-filter method

$$q_{mPM} = \left\{ \frac{m_f}{m_{sep}} - \left[ \frac{m_{f,d}}{m_d} \cdot \sum_{i=1}^N \left( 1 - \frac{1}{D_i} \right) \cdot WF_i \right] \right\} \cdot \frac{q_{medf}}{1000} \quad (\text{A.8-58})$$

(d) For the multiple-filter method

$$q_{mPM} = \left\{ \frac{m_{fi}}{m_{sepi}} - \left[ \frac{m_{f,d}}{m_d} \cdot \left( 1 - \frac{1}{D} \right) \right] \right\} \cdot \frac{q_{medfi}}{1000} \quad (\text{A.8-59})$$

Where:

- $q_{mPM}$  = particulate mass flow rate [g/h]  
 $WF_i$  = weighting factor for the mode  $i$  [-]  
 $m_f$  = particulate sample mass collected [mg]  
 $m_{fi}$  = particulate sample mass collected at mode  $i$  [mg]  
 $m_{f,d}$  = particulate sample mass of the dilution air collected [mg]  
 $q_{medfi}$  = equivalent diluted exhaust gas mass flow rate on wet basis at mode  $i$  [kg/h]  
 $m_{sep}$  = mass of diluted exhaust sample passed through the particulate sampling filter [kg]  
 $m_{sepi}$  = mass of diluted exhaust sample passed through the particulate sampling filter at mode  $i$  [kg]  
 $m_d$  = mass of the dilution air sample passed through the particulate sampling filters [kg]  
 $D$  = dilution factor (see equation (A.8-29) of paragraph A.8.3.2.2.) [-]

If more than one measurement is made,  $m_{f,d}/m_d$  shall be replaced with  $\overline{m_{f,d}/m_d}$ .

A.8.4. Cycle work and specific emissions

## A.8.4.1. Gaseous emissions

## A.8.4.1.1. Transient and ramped modal cycles

Reference is made to paragraphs A.8.2.1. and A.8.3.1. for raw and diluted exhaust respectively. The resulting values for power  $P$  [kW] shall be integrated over a test interval. The total work  $W_{act}$  [kWh] is calculated as follows:

$$W_{act} = \sum_{i=1}^N P_i \cdot \Delta t_i = \frac{1}{f} \cdot \frac{1}{3600} \cdot \frac{1}{10^3} \frac{2 \cdot \pi}{60} \sum_{i=1}^N (n_i \cdot T_i) \quad (\text{A.8-60})$$

Where:

$P_i$ =	instantaneous engine power [kW]
$n_i$ =	instantaneous engine speed [rpm]
$T_i$ =	instantaneous engine torque [Nm]
$W_{act}$ =	actual cycle work [kWh]
$f$ =	data sampling rate [Hz]
$N$ =	number of measurements [-]

The specific emissions  $e_{gas}$  [g/kWh] shall be calculated in the following ways depending on the type of test cycle.

$$e_{gas} = \frac{m_{gas}}{W_{act}} \quad (\text{A.8-61})$$

Where:

$m_{gas}$ =	total mass of emission [g/test]
$W_{act}$ =	cycle work [kWh]

In case of the transient cycle, the final test result  $e_{gas}$  [g/kWh] shall be a weighted average from cold start test and hot start test by using:

$$e_{gas} = \frac{(0.1 \cdot m_{cold}) + (0.9 \cdot m_{hot})}{(0.1 \cdot W_{act,cold}) + (0.9 \cdot W_{act,hot})} \quad (\text{A.8-62})$$

In case of an infrequent (periodic) exhaust regeneration (paragraph 6.6.2.), the specific emissions shall be corrected with the multiplicative adjustment factor  $k_r$  (equation (6-4)) or with the two separate pairs of adjustment additive factors  $k_{Ur}$  (upward factor of equation (6-5)) and  $k_{Dr}$  (downward factor of equation (6-6)).

## A.8.4.1.2. Steady-state discrete-mode cycle

The specific emissions  $e_{\text{gas}}$  [g/kWh] are calculated as follows:

$$e_{\text{gas}} = \frac{\sum_{i=1}^{N_{\text{mode}}} (q_{m\text{gas},i} \cdot WF_i)}{\sum_{i=1}^{N_{\text{mode}}} (P_i \cdot WF_i)} \quad (\text{A.8-63})$$

Where:

- $q_{m\text{gas},i}$  = mean emission mass flow rate for the mode  $i$  [g/h]  
 $P_i$  = engine power for the mode  $i$  [kW] with  $P_i = P_{\text{max},i} + P_{\text{aux},i}$  (see paragraphs 7.7.1.2. and 6.3.)  
 $WF_i$  = weighting factor for the mode  $i$  [-]

## A.8.4.2. Particulate emissions

## A.8.4.2.1. Transient and ramped modal cycles

The particulate specific emissions shall be calculated with equation (A.8-61) where  $e_{\text{gas}}$  [g/kWh] and  $m_{\text{gas}}$  [g/test] are substituted by  $e_{\text{PM}}$  [g/kWh] and  $m_{\text{PM}}$  [g/test] respectively:

$$e_{\text{PM}} = \frac{m_{\text{PM}}}{W_{\text{act}}} \quad (\text{A.8-64})$$

Where:

- $m_{\text{PM}}$  = total mass of particulates emission, calculated according to paragraph A.8.3.4. [g/test]  
 $W_{\text{act}}$  = cycle work [kWh]

The emissions on the transient composite cycle (i.e. cold phase and hot phase) shall be calculated as shown in paragraph A.8.4.1.

## A.8.4.2.2. Steady state discrete-mode cycle

The particulate specific emission  $e_{\text{PM}}$  [g/kWh] shall be calculated in the following way:

- (a) For the single-filter method

$$e_{\text{PM}} = \frac{q_{m\text{PM}}}{\sum_{i=1}^N (P_i \cdot WF_i)} \quad (\text{A.8-65})$$



Where:

$P_i$  = engine power for the mode  $i$  [kW] with  $P_i = P_{\max i} + P_{\text{aux}i}$  (see paragraphs 7.7.1.2. and 6.3.)

$WF_i$  = weighting factor for the mode  $i$  [-]

$q_{\text{mPM}}$  = particulate mass flow rate [g/h]

(b) For the multiple-filter method

$$e_{\text{PM}} = \frac{\sum_{i=1}^N (q_{\text{mPM}i} \cdot WF_i)}{\sum_{i=1}^N (P_i \cdot WF_i)} \quad (\text{A.8-66})$$

Where:

$P_i$  = engine power for the mode  $i$  [kW] with  $P_i = P_{\max i} + P_{\text{aux}i}$  (see paragraphs 7.7.1.2. and 6.3.)

$WF_i$  = weighting factor for the mode  $i$  [-]

$q_{\text{mPM}i}$  = particulate mass flow rate at mode  $i$  [g/h]

For the single-filter method, the effective weighting factor,  $WF_{ei}$ , for each mode shall be calculated in the following way:

$$WF_{ei} = \frac{m_{\text{sepi}} \cdot \overline{q_{\text{medf}}}}{m_{\text{sep}} \cdot q_{\text{medfi}}} \quad (\text{A.8-67})$$

Where:

$m_{\text{sepi}}$  = mass of the diluted exhaust sample passed through the particulate sampling filters at mode  $i$  [kg]

$\overline{q_{\text{medf}}}$  = average equivalent diluted exhaust gas mass flow rate [kg/s]

$q_{\text{medfi}}$  = equivalent diluted exhaust gas mass flow rate at mode  $i$  [kg/s]

$m_{\text{sep}}$  = mass of the diluted exhaust sample passed through the particulate sampling filters [kg]

The value of the effective weighting factors shall be within  $\pm 0.005$  (absolute value) of the weighting factors listed in Annex A.1.

Annex A.8 - Appendix 1

## DILUTED EXHAUST FLOW (CVS) CALIBRATION

- A.8.1. The CVS system shall be calibrated by using an accurate flowmeter and a restricting device. The flow through the system shall be measured at different restriction settings, and the control parameters of the system shall be measured and related to the flow.

Various types of flowmeters may be used, e.g. calibrated venturi, calibrated laminar flowmeter, calibrated turbine meter.

- A.8.1.1. Positive displacement pump (PDP)

All the parameters related to the pump shall be simultaneously measured along with the parameters related to a calibration venturi which is connected in series with the pump. The calculated flow rate (in m<sup>3</sup>/s at pump inlet, absolute pressure and temperature) shall be plotted versus a correlation function which is the value of a specific combination of pump parameters. The linear equation which relates the pump flow and the correlation function shall be determined. If a CVS has a multiple speed drive, the calibration shall be performed for each range used.

Temperature stability shall be maintained during calibration.

Leaks in all the connections and ducting between the calibration venturi and the CVS pump shall be maintained lower than 0.3 per cent of the lowest flow point (highest restriction and lowest PDP speed point).

The airflow rate ( $q_{VCVS}$ ) at each restriction setting (minimum 6 settings) shall be calculated in standard m<sup>3</sup>/s from the flowmeter data using the manufacturer's prescribed method. The airflow rate shall then be converted to pump flow ( $V_0$ ) in m<sup>3</sup>/rev at absolute pump inlet temperature and pressure as follows:

$$V_0 = \frac{q_{VCVS}}{n} \cdot \frac{T}{273} \cdot \frac{101.3}{p_p} \quad (\text{A.8-68})$$

Where:

$q_{VCVS}$  = airflow rate at standard conditions (101.3 kPa, 273 K) [m<sup>3</sup>/s]  
 $T$  = temperature at pump inlet [K]  
 $p_p$  = absolute pressure at pump inlet [kPa]  
 $n$  = pump speed [rev/s]

To account for the interaction of pressure variations at the pump and the pump slip rate, the correlation function ( $X_0$ ) [s/rev] between pump speed, pressure differential from pump inlet to pump outlet and absolute pump outlet pressure shall be calculated as follows:

$$X_0 = \frac{1}{n} \cdot \sqrt{\frac{\Delta p_p}{p_p}} \quad (\text{A.8-69})$$

Where:

$\Delta p_p$  = pressure differential from pump inlet to pump outlet [kPa]  
 $p_p$  = absolute outlet pressure at pump outlet [kPa]  
 $n$  = pump speed [rev/s]

A linear least-square fit shall be performed to generate the calibration equation as follows:

$$V_0 = D_0 - m \cdot X_0 \quad (\text{A.8-70})$$

with  $D_0$  [ $\text{m}^3/\text{rev}$ ] and  $m$  [ $\text{m}^3/\text{s}$ ], intercept and slope respectively, describing the regression line.

For a CVS system with multiple speeds, the calibration curves generated for the different pump flow ranges shall be approximately parallel, and the intercept values ( $D_0$ ) shall increase as the pump flow range decreases.

The calculated values from the equation shall be within  $\pm 0.5$  per cent of the measured value of  $V_0$ . Values of  $m$  will vary from one pump to another. Particulate influx over time will cause the pump slip to decrease, as reflected by lower values for  $m$ . Therefore, calibration shall be performed at pump start-up, after major maintenance, and if the total system verification indicates a change of the slip rate.

#### A.8.1.2. Critical flow venturi (CFV)

Calibration of the CFV is based upon the flow equation for a critical venturi. Gas flow is a function of venturi inlet pressure and temperature.

To determine the range of critical flow,  $K_V$  shall be plotted as a function of venturi inlet pressure. For critical (choked) flow,  $K_V$  will have a relatively constant value. As pressure decreases (vacuum increases), the venturi becomes unchoked and  $K_V$  decreases, which indicates that the CFV is operated outside the permissible range.

The airflow rate ( $q_{VCVS}$ ) at each restriction setting (minimum 8 settings) shall be calculated in standard  $\text{m}^3/\text{s}$  from the flowmeter data using the manufacturer's prescribed method. The calibration coefficient  $K_V$  [ $(\sqrt{\text{K}} \cdot \text{m}^4 \cdot \text{s})/\text{kg}$ ] shall be calculated from the calibration data for each setting as follows:

$$K_V = \frac{q_{VCVS} \cdot \sqrt{T}}{p_p} \quad (\text{A.8-71})$$

Where:

$q_{VSSV}$  = air flow rate at standard conditions (101.3 kPa, 273 K) [ $\text{m}^3/\text{s}$ ]

$T$  = temperature at the venturi inlet [K]

$p_p$  = absolute pressure at venturi inlet [kPa]

The average  $K_V$  and the standard deviation shall be calculated. The standard deviation shall not exceed  $\pm 0.3$  per cent of the average  $K_V$ .

#### A.8.1.3. Subsonic venturi (SSV)

Calibration of the SSV is based upon the flow equation for a subsonic venturi. Gas flow is a function of inlet pressure and temperature, pressure drop between the SSV inlet and throat, as shown in equation (A.8-41).

The airflow rate ( $q_{VSSV}$ ) at each restriction setting (minimum 16 settings) shall be calculated in standard  $\text{m}^3/\text{s}$  from the flowmeter data using the manufacturer's prescribed method. The discharge coefficient shall be calculated from the calibration data for each setting as follows:

$$C_d = \frac{q_{VSSV}}{d_v^2 p_p \sqrt{\left[ \frac{1}{T_{in,V}} (r_p^{1.4286} - r_p^{1.7143}) \left( \frac{1}{1 - r_D^4 r_p^{1.4286}} \right) \right]}} \quad (\text{A.8-72})$$

Where:

$q_{VSSV}$  = air flow rate at standard conditions (101.3 kPa, 273 K) [ $\text{m}^3/\text{s}$ ]

$T_{in,V}$  = temperature at the venturi inlet [K]

$d_v$  = diameter of the SSV throat [m]

$r_p$  = ratio of the SSV throat to inlet absolute static pressure =  $1 - \Delta p / p_p$  [-]

$r_D$  = ratio of the SSV throat diameter,  $d_v$ , to the inlet pipe inner diameter  $D$  [-]

To determine the range of subsonic flow,  $C_d$  shall be plotted as a function of Reynolds number  $Re$ , at the SSV throat. The  $Re$  at the SSV throat shall be calculated with the following equation:

$$Re = A_1 \cdot \frac{q_{VSSV}}{d_v \cdot \mu} \quad (\text{A.8-73})$$

with

$$\mu = \frac{b \times T^{1.5}}{S + T} \quad (\text{A.8-74})$$

Where:

$$A_1 = 25.55152 \text{ in units of } \left(\frac{1}{m^3}\right)\left(\frac{\text{min}}{s}\right)\left(\frac{\text{mm}}{m}\right)$$

$q_{VSSV}$  = air flow rate at standard conditions (101.3 kPa, 273 K) [ $m^3/s$ ]

$d_V$  = diameter of the SSV throat [m]

$\mu$  = absolute or dynamic viscosity of the gas [kg/ms]

$b$  =  $1.458 \times 10^6$  (empirical constant) [ $\text{kg/msK}^{0.3}$ ]

$S$  = 110.4 (empirical constant) [K]

Because  $q_{VSSV}$  is an input to the  $Re$  equation, the calculations shall be started with an initial guess for  $q_{VSSV}$  or  $C_d$  of the calibration venturi, and repeated until  $q_{VSSV}$  converges. The convergence method shall be accurate to 0.1 per cent of point or better.

For a minimum of sixteen points in the region of subsonic flow, the calculated values of  $C_d$  from the resulting calibration curve fit equation shall be within  $\pm 0.5$  per cent of the measured  $C_d$  for each calibration point.

Annex A.8 – Appendix 2

## DRIFT CORRECTION

A.8.2. Calculations in this appendix are performed as described in Appendix 2 to Annex A.7.

$$c_{\text{idriftcor}} = c_{\text{refzero}} + (c_{\text{refspan}} - c_{\text{refzero}}) \frac{2c_i - (c_{\text{prezero}} + c_{\text{postzero}})}{(c_{\text{prespan}} + c_{\text{postspan}}) - (c_{\text{prezero}} + c_{\text{postzero}})} \quad (\text{A.8-75})$$

Where:

- $c_{\text{idriftcor}}$  = concentration corrected for drift [ppm]
- $c_{\text{refzero}}$  = reference concentration of the zero gas, which is usually zero unless known to be otherwise [ppm]
- $c_{\text{refspan}}$  = reference concentration of the span gas [ppm]
- $c_{\text{prespan}}$  = pre-test interval gas analyzer response to the span gas concentration [ppm]
- $c_{\text{postspan}}$  = post-test interval gas analyzer response to the span gas concentration [ppm]
- $c_i$  or  $\bar{c}$  = concentration recorded, i.e. measured, during test, before drift correction [ppm]
- $c_{\text{prezero}}$  = pre-test interval gas analyzer response to the zero gas concentration [ppm]
- $c_{\text{postzero}}$  = post-test interval gas analyzer response to the zero gas concentration [ppm]

-----