

**JAMA Proposal for ELSA meeting, January 22, 2009****ELECTRICAL SAFETY PROVISIONS FOR VEHICLES IN USE**

Attached Sheet 1

**ISOLATION RESISTANCE MEASUREMENT METHOD****1. General**

The isolation resistance of whole vehicle shall be determined by measuring for the whole vehicle at a time, or by calculation from the measured value of each part or component of the high voltage bus.

**2. Measurement Method**

The isolation resistance measurement shall be conducted by selecting an appropriate measurement method from among those listed in Paragraphs 2-1 through 2-3, depending on the electrical charge of the live parts or the isolation resistance, etc.

The range of the electrical circuit to be measured shall be clarified in advance, using electrical circuit diagrams, etc.

Moreover, modification necessary for measuring the isolation resistance may be carried out, such as removal of the cover in order to reach the live parts, drawing of measurement lines, change in software, etc.

In cases where the measured values are not stable due to the operation of the on-board isolation resistance monitoring system, etc., necessary modification for conducting the measurement may be carried out, such as stopping of the operation of the device concerned or removing it. Furthermore, when the device is removed, it must be proven, using drawings, etc., that it will not change the isolation resistance between the live parts and the electrical chassis.

Utmost care must be exercised as to short circuit, electric shock, etc., for this confirmation might require direct operations of the high-voltage circuit.

**2-1 Measurement method using DC voltage from off-vehicle sources****2-1-1 Measurement instrument**

An isolation resistance test instrument capable of applying a DC voltage higher than the **maximum** working voltage of the high voltage bus shall be used.

**2-1-2 Measurement method**

An insulator resistance test instrument shall be connected between the live parts and the electrical chassis. Then, the isolation resistance shall be measured by applying a DC voltage higher than the **maximum** working voltage of the high voltage bus **and coupling system for charging the RESS, respectively.**

**If the system has several voltage ranges (e.g. because of boost converter) in galvanically connected circuit and some of the components can not withstand the working voltage of the entire circuit, the isolation resistance between those components and the electrical chassis can be measured separately by applying their own working voltage with those component disconnected.**

**Comment [トヨタ自動車株式会社]**  
Some fuel cell engineers are worrying that the Fuel cell may be destroyed when the working voltage of the entire system, which is higher than the working voltage of the fuel cell, is applied.

[However, in cases where there is likelihood that parts are damaged during the measurement, because no appropriate application voltage is obtained due to the characteristics of the isolation resistance test instrument, it shall be permissible to perform the measurement with the next lower voltage level of the test instrument, or with those parts removed.]

Comment [トヨタ自動車株式会社  
Some HVs have voltage boost system which raises the working voltage to more than 2 times of the RESS voltage. We cannot make the voltage to such high voltage level in a static measurement.

2-2 Measurement method using the vehicle's own RESS as DC voltage source

2-2-1 Test vehicle conditions

The high voltage-bus shall be energized by the vehicle's own RESS and/or energy conversion system and the voltage level of the RESS and/or energy conversion system throughout the test shall be at least the nominal operating voltage as specified by the vehicle manufacturer.

Comment [トヨタ自動車株式会社  
added the words "of the RESS and/or energy conversion system". Some HVs have voltage boost system which raise the working voltage to more than 2 times of the RESS voltage. We cannot make the voltage level to such high voltage in a static measurement.

2-2-2 Measurement instrument

The voltmeter used in this test shall measure DC values and shall have an internal resistance of at least 10 MΩ.

2-2-3 Measurement method

2-2-3-1 First step

The voltage is measured as shown in Figure 1 and the high voltage Bus voltage ( $V_b$ ) is recorded.  $V_b$  shall be equal to or greater than the nominal operating voltage of the RESS and/or energy conversion system as specified by the vehicle manufacturer.

Comment [トヨタ自動車株式会社  
ame as 2-2-1.

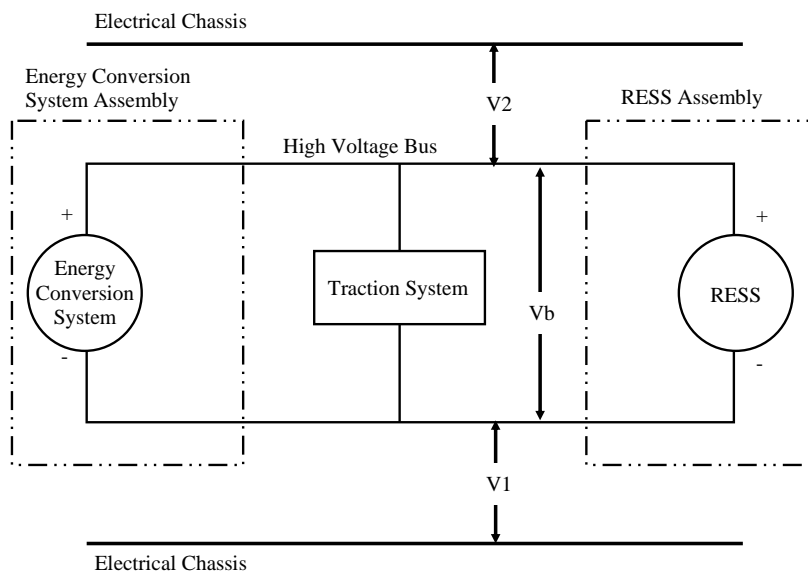

Figure 1: Measurement of  $V_b$ ,  $V_1$ ,  $V_2$

2-2-3-2 Second step

Measure and record the voltage ( $V_1$ ) between the negative side of the high voltage bus and the electrical chassis (see Figure 1):

2-2-3-3 Third step

Measure and record the voltage (V2) between the positive side of the high voltage bus and the electrical chassis (see Figure 1).

2-2-3-4 Fourth step

If V1 is greater than or equal to V2, insert a standard known resistance (Ro) between the negative side of the high voltage bus and the electrical chassis. With Ro installed, measure the voltage (V1') between the negative side of the high voltage bus and the electrical chassis (see Figure 2).

Calculate the electrical isolation (Ri) according to the following formula:

$$Ri = Ro * (Vb / V1' - Vb / V1) \text{ or } Ri = Ro * Vb * (1 / V1' - 1 / V1)$$

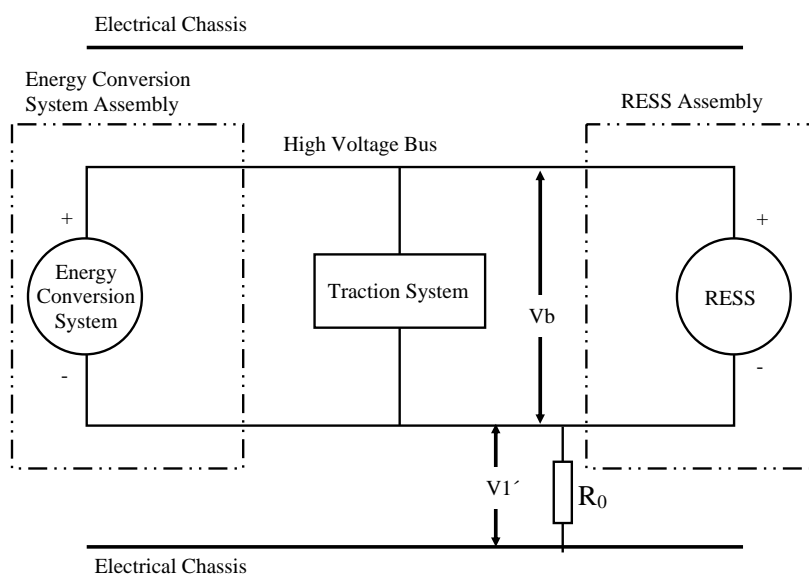

Figure 2: Measurement of V1'

If V2 is greater than V1, insert a standard known resistance (Ro) between the positive side of the high voltage bus and the electrical chassis. With Ro installed, measure the voltage (V2') between the positive side of the high voltage bus and the electrical chassis. (See Figure 3). Calculate the electrical isolation (Ri) according to the formula shown. Divide this electrical isolation value (in ohms) by the nominal operating voltage of the high voltage bus (in volts).

Calculate the electrical isolation (Ri) according to the following formula:

$$Ri = Ro * (Vb / V2' - Vb / V2) \text{ or } Ri = Ro * Vb * (1 / V2' - 1 / V2)$$

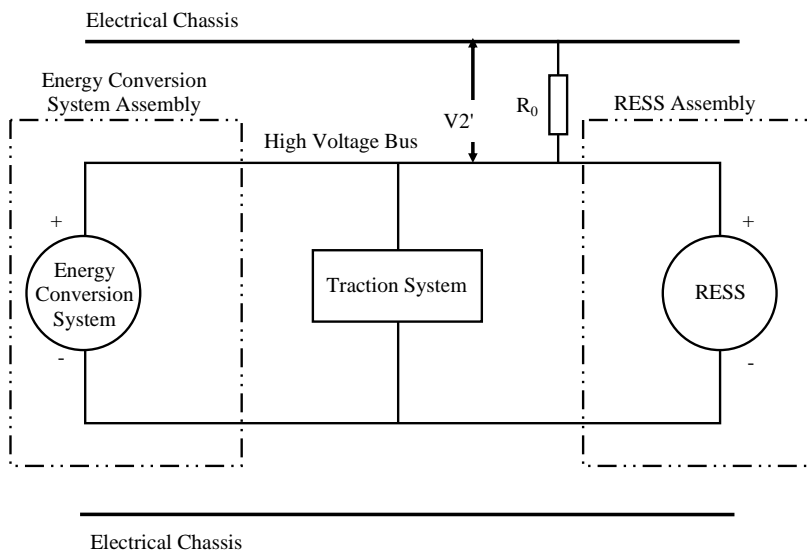

Figure 3: Measurement of V2'

2-2-3-5 Fifth step

The electrical isolation value  $R_i$  (in ohms) divided by the ~~maximum operating working~~ voltage of the high voltage bus (in volts) results in the isolation resistance (in ohms/volt).

**NOTE 1:** The standard known resistance  $R_0$  (in ohms) should be ~~approximately 500 times~~ the value of the minimum required isolation resistance (in ohms/V) multiplied by the ~~nominal operating working~~ voltage of the vehicle plus minus 20% (in volts).  $R_0$  is not required to be precisely this value since the equations are valid for any  $R_0$ ; however, a  $R_0$  value in this range should provide good resolution for the voltage measurements.

**Comment** [トヨタ自動車株式会社] heoretically,  $R_0$  value of the minimum required isolation resistance (in ohms/V) multiplied by the nominal operating working voltage of the vehicle (in volts) will provide good resolution for the voltage measurement if the isolation resistance is around the minimum required value.

**Comment** [トヨタ自動車株式会社] Plus minus 20% " is the suggestion by the authority of Japanese government. There is no rational reason.

Attached Sheet 2

### CONFIRMATION METHOD FOR FUNCTIONS OF ON-BOARD ISOLATION RESISTANCE MONITORING SYSTEM

The function of the on-board isolation resistance monitoring system shall be confirmed by the following method or a method equivalent to it

When a resistor is inserted which causes the isolation resistance between the terminal being monitored and the electrical chassis to drop **below to the minimum required isolation resistance value**, the warning shall be activated.

**However, if the isolation resistance between the terminal being monitored and the electrical chassis cannot be set to the minimum required isolation resistance value due to the resistance of a resistor inserted, the setting shall be made to the smallest possible resultant resistance of the minimum required isolation resistance value or greater.**

**Comment** [トヨタ自動車株式会社]  
e can accept the requirement of "onboard isolation resistance monitoring system together with a warning to the driver if the isolation resistance drops to the minimum required value ". However, the characteristics of the onboard isolation resistance monitoring system should be such that it can detect the isolation drop immediately the isolation becomes below the requirement.

Attached Sheet 3

## PROTECTION AGAINST DIRECT CONTACTS OF PARTS UNDER VOLTAGE

### 1. General

This test method shall apply to the electrical power train whose working voltage does not exceeding 1,000 V AC and 1,500 V DC.

### 2. Access probes

Access probes to verify the protection of persons against access to live parts are given in table 1.

### 3. Test conditions

The access probe is pushed against any openings of the enclosure with the force specified in table 1. If it partly or fully penetrates, it is placed in every possible position, but in no case shall the stop face fully penetrate through the opening.

Internal barriers are considered part of the enclosure.

A low-voltage supply (of not less than 40 V and not more than 50 V) in series with a suitable lamp should be connected, if necessary, between the probe and live parts inside the barrier or enclosure. Live parts covered only with varnish or paint which is not intended for solid insulator, or protected by oxidation or by a similar process, are covered by a metal foil electrically connected to those parts which are normally live in operation.

The signal-circuit method should also be applied to the moving live parts of high voltage equipment.

Internal moving parts may be operated slowly, where this is possible.

### 4. Acceptance conditions

The access probe shall not touch live parts.

If this requirement is verified by a signal circuit between the probe and live parts, the lamp shall not light.

In the case of the test for IPXXB, the jointed test finger may penetrate to its 80 mm length, but the stop face (diameter 50 mm x 20 mm) shall not pass through the opening. Starting from the straight position, both joints of the test finger shall be successively bent through an angle of up to 90 degree with respect to the axis of the adjoining section of the finger and shall be placed in every possible position.

In case of the tests for IPXXD, the access probe may penetrate to its full length, but the stop face shall not fully penetrate through the opening.

**Table 1** - Access probes for the tests for protection of persons against access to hazardous parts

First numeral	Addit. letter	Access probe	Test force
2	B	<p style="text-align: center;"><b>Jointed test finger</b></p>  <p>See Fig. 1 for full dimensions</p>	10N+/-10%
4.5.6	D	<p style="text-align: center;">Test wire 1.0 mm diameter 100 mm long</p> 	1N+/-10%

Figure 1 - Jointed test finger



Material: metal, except where otherwise specified

Linear dimensions in millimeters

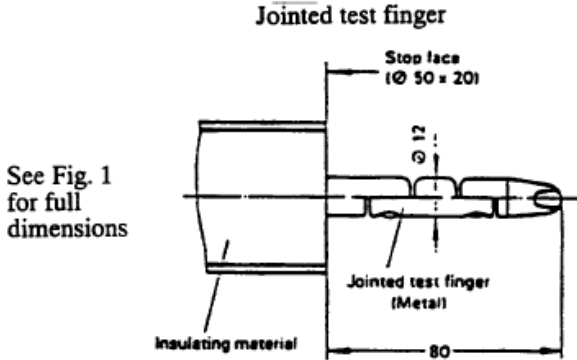
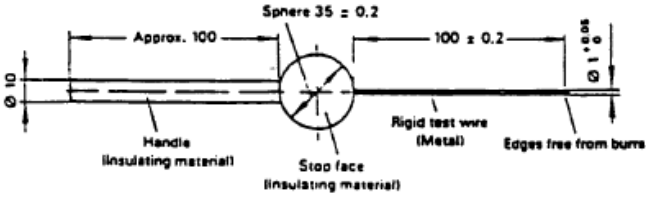
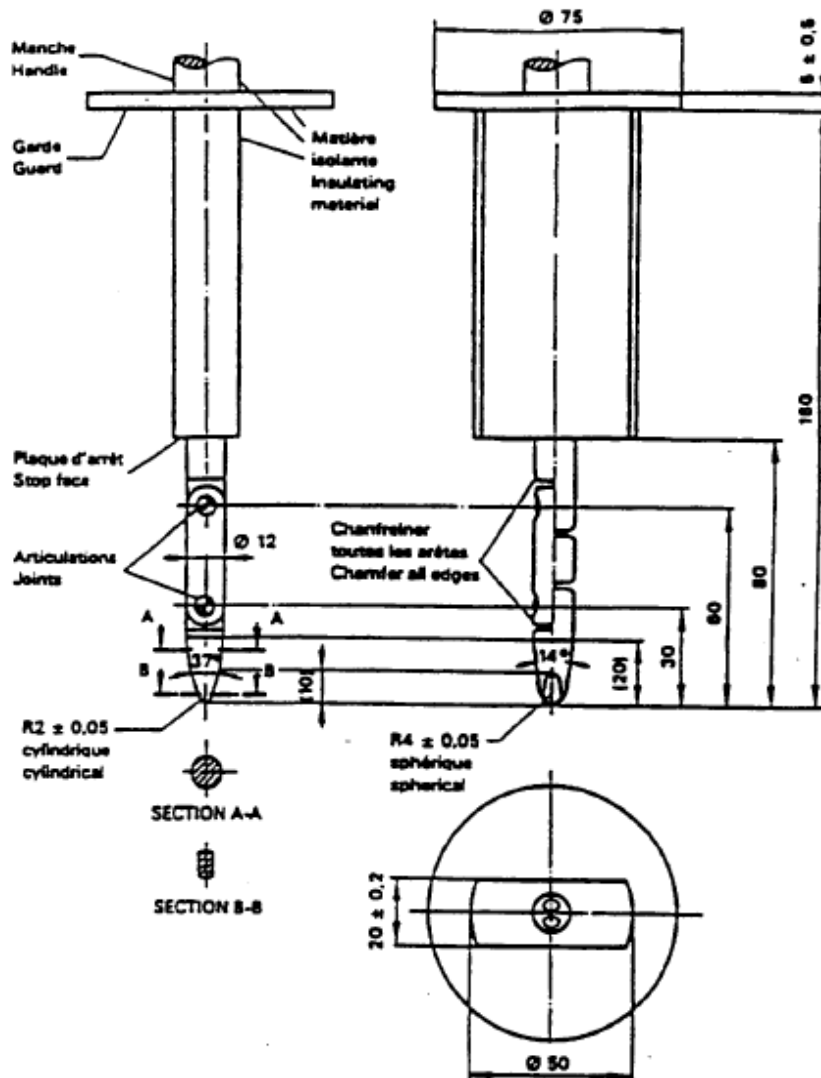
Tolerances on dimensions without specific tolerance:

on angles,  $0/-10'$

on linear dimensions:

up to 25 mm:  $0/-0.05$

over 25 mm:  $\pm 0.2$

Both joints shall permit movement in the same plane and the same direction through an angle of  $90^\circ$  with a  $0$  to  $+10^\circ$  tolerance.



**PROTECTION DEGREES**~~4 IPXXB~~

Jointed test finger diameter 12; 80 length      Dimensions in millimetres

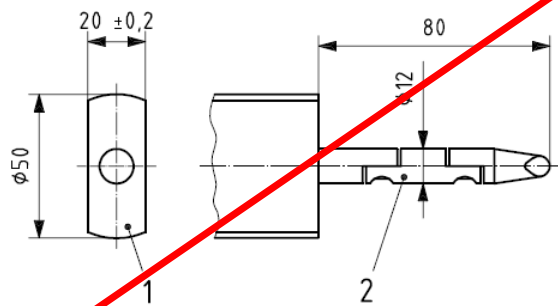
**Key**

- 1 stop face (diameter 50 × 20) (insulating material)
- 2 jointed test finger (metal)

~~The jointed test finger may penetrate over its full length of 80 mm but shall not contact the hazardous parts, even when its joints are bent at any optional angle (up to 90° from its axis) and are brought into any possible position. The stop face (Ø50 mm × 20 mm) shall not pass through the opening.~~

~~The test force shall be 10 N ± 10 %.~~

~~2 IPXXD~~

Test wire diameter 1,0; 100 long

Dimensions in millimetres

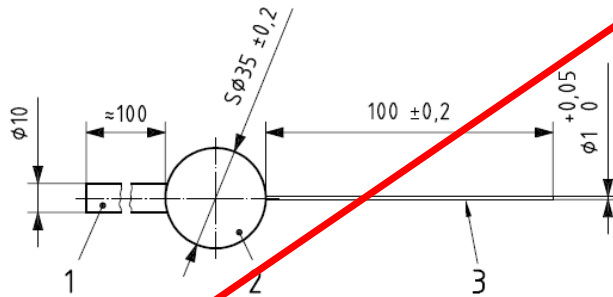

Key

- 1 handle (insulating material)
- 2 stop face (insulating material)
- 3 sphere
- 4 rigid test wire (metal) (edges free from burrs)

~~The rigid test wire (diameter 1,0 mm, 100 mm long) may penetrate over its full length of 100 mm, but shall be sufficiently distant from hazardous parts in any possible angular position. The stop face (sphere Ø35 mm) shall not pass through the opening. The test force shall be 1 N ± 10 %.~~