

**Economic and Social Council**

Distr.: General

28 August 2012

English only

Economic Commission for Europe

Inland Transport Committee

World Forum for Harmonization of Vehicle Regulations**Working Party on Lighting and Light-Signalling****Sixty-eighth session**

Geneva, 16–18 October 2012

Item 18(f) of the provisional agenda

Regulation No. 10 (Electromagnetic compatibility)**Proposal for the 05 series of amendments to Regulation
No. 10 (Electromagnetic compatibility)****Submitted by the experts from OICA***

The text reproduced below was prepared by the experts from the International Organization of Vehicle Manufacturers (OICA) extending the scope of the present Regulation to all kinds of power train systems above a certain working voltage level, when they are in charging mode. For configuration "REESS charging mode coupled to power grid" Regulation No. 10, 04 series of amendments covers only type approval for complete vehicles. This proposal extends the type approval to separate electrical components (ESAs) for the afore-mentioned configuration. This proposal includes updated vehicle tests for REESS charging systems to be in line with the referenced CISPR and ISO standards. The modifications to the existing text of Regulation No. 10 are marked in bold for new or strikethrough for deleted characters.

* In accordance with the programme of work of the Inland Transport Committee for 2010–2014 (ECE/TRANS/208, para. 106, ECE/TRANS/2010/8, programme activity 02.4), the World Forum will develop, harmonize and update Regulations in order to enhance the performance of vehicles. The present document is submitted in conformity with that mandate.

I. Proposal

Contents, Paragraph 6, amend to read:

- "6. Specifications in configurations other than "REESS RESS charging mode coupled to the power grid"

Paragraph 7, amend to read:

- "7. Additional specifications in the configuration "REESS RESS charging mode coupled to the power grid"

Annexes, insert new Annexes 17 to 22, to read:

- "17 Method(s) of testing for emission of harmonics generated on AC power lines from an ESA
- 18 Method(s) of testing for emission of voltage changes, voltage fluctuations and flicker on AC power lines from an ESA
- 19 Method(s) of testing for emission of radiofrequency conducted disturbances on AC or DC power lines from an ESA
- 20 Method(s) of testing for emission of radiofrequency conducted disturbances on network and telecommunication access from an ESA
- 21 Method of testing for immunity of an ESA to electrical fast transient/burst disturbances conducted along AC and DC power lines
- 22 Method of testing for immunity of ESAs to surges conducted along AC and DC power lines"

Paragraph 1.3., amend to read:

- "1.3. It covers:
- (a) requirements regarding the immunity... vehicle statutory data;
 - (b) requirements regarding the control ...retrofitted to the vehicle.
 - (c) additional requirements for vehicles **and ESAs** providing coupling systems for charging the **REESS** regarding the control of emissions and immunity from this connection between vehicle and power grid."

Paragraphs 2.5. to 2.7., amend to read:

- "2.5. "Broadband emission" means an emission, which has a bandwidth greater than that of a particular measuring apparatus or receiver (~~International Special Committee on Radio Interference (CISPR) 25, second edition 2002 and corrigendum 2004.~~).
- 2.6. "Narrowband emission" means an emission which has a bandwidth less than that of a particular measuring apparatus or receiver (~~CISPR 25, second edition 2002 and corrigendum 2004.~~).
- 2.7. "Electrical/electronic system" means (an) electrical and/or electronic device(s) or set(s) of devices together with any associated electrical connections which form part of a vehicle but which are not intended to be type approved separately from the vehicle. ~~Both RESS and Coupling system for charging the RESS are considered electrical / electronic systems."~~

Paragraphs 2.12. to 2.14., amend to read:

- "2.12. "Immunity related functions" are:
- (a) Functions related to the direct control of the vehicle:
 - (i) ...
 -
 - (f) Function related to ~~the RESS in~~ charging mode **when** coupled to the power grid:
 - (i) **for vehicle test:** by leading to unexpected vehicle motion
 - (ii) **for ESA test: by leading to an incorrect charging condition (e.g. over-current, over-voltage)**
- 2.13. "**REESS**" means the rechargeable energy storage system that provides electric energy for electric propulsion of the vehicle.
- 2.14. "*Coupling system for charging the ~~RESS~~ REESS*" means the electrical circuit installed in the vehicle used for charging the ~~RESS~~ REESS."

Insert new paragraph 2.15., to read:

- "2.15. "REESS charging mode coupled to the power grid" means the normal charging operation mode of the vehicle and/or charging system."**

Paragraph 3.1.3., amend to read:

- "3.1.3. The vehicle manufacturer shall draw up ... and those which provide coupling systems for charging the **REESS**."

Paragraph 3.1.9., amend to read:

- "3.1.9. Vehicle type approval shall be applied for both **REESS** and coupling system for charging the **REESS** as they are considered as electrical/electronic systems."

Paragraph 3.2.1., amend to read:

- "3.2.1. Applicability of this Regulation to ESA:

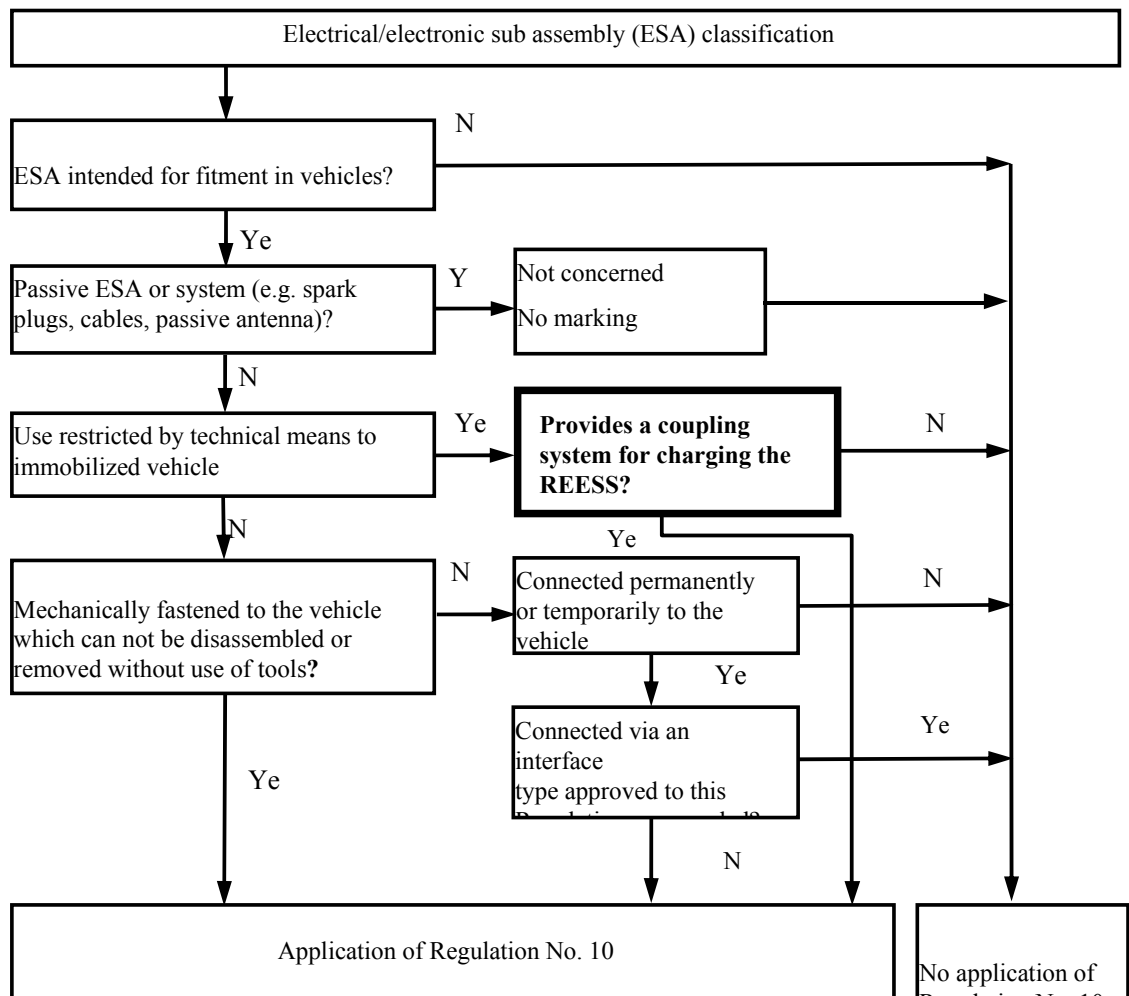

Paragraph 3.2.9., amend to read:

"3.2.9. Components sold as aftermarket equipment and intended for the installation in motor vehicles need no type approval if they are not related to immunity related functions (see paragraph 2.12.). In this case a declaration must be issued by the manufacturer that the ESA fulfils the requirements of this Regulation and in particular the limits defined in paragraphs 6.5., 6.6., **6.7.**, 6.8. and 6.9."

Paragraph 4.1.1.1., amend to read:

"4.1.1.1. Approval of a vehicle installation

A vehicle installation may be type approved directly by following the provisions laid down in paragraph 6 **and if applicable in paragraph 7** of this Regulation. If this procedure is chosen by a vehicle manufacturer, no separate testing of electrical/electronic systems or ESAs is required."

Paragraph 4.2.1.1., amend to read:

"4.2.1.1. If the representative vehicle fulfils the requirements of paragraph 6 **and if applicable paragraph 7** of this Regulation, type approval shall be granted."

Paragraph 4.2.2.1., amend to read:

"4.2.2.1. If the representative ESA system(s) fulfil(s) the requirements of paragraph 6 **and if applicable paragraph 7** of this Regulation, type approval shall be granted."

Paragraph 5.1., amend to read:

"5.1. An approval number shall be assigned to each vehicle or ESA type approved. The first two digits of this number (at present 05) shall indicate the series of amendments corresponding to the most recent essential technical amendments made to the Regulation at the date of approval. A Contracting Party may not assign the same approval number to another type of vehicle or ESA."

Paragraph 6., amend to read:

"6. Specification in configurations other than "REESS charging mode coupled to the power grid"

Paragraphs 6.9. and 6.9.1., renumber as paragraphs 6.7. and 6.7.1., and amend to read:

"6.7. Specifications concerning the emission of transient conducted disturbances generated by ESAs on **12/24 V** supply lines.

6.7.1. Method of testing

The emission of ESA representative of its type shall be tested by the method(s) according to ISO 7637-2 (~~second edition 2004~~) as described in Annex 10 for the levels given in Table ~~2~~ **1**.

Table ~~2~~ **1**

Maximum allowed pulse amplitude

Polarity of pulse amplitude	<i>Maximum allowed pulse amplitude for</i>	
	Vehicles with 12 V systems	Vehicles with 24 V systems
Positive	+75	+150
Negative	-100	-450

"

Paragraphs 6.7. to 6.7.2.2., renumber as paragraphs 6.8. to 6.8.2.2.

Paragraphs 6.8. and 6.8.1., renumber as paragraphs 6.9. and 6.9.1. and amend to read:

"6.9. Specifications concerning the immunity of ESAs to transient disturbances conducted along **12/24 V** supply lines.

6.9.1. Method of testing

The immunity of ESA representative of this type shall be tested by the method(s) according to ISO 7637-2 (~~second edition 2004~~) as described in Annex 10 with the test levels given in Table ~~2~~ **2**.

Table 4 2
Immunity of ESA

Test pulse number	Immunity test level	Functional status for systems:	
		Related to immunity related functions	Not related to immunity related functions
1	III	C	D
2a	III	B	D
2b	III	C	D
3a/3b	III	A	D
4	III	B	D
		(for ESA which must be operational during engine start phases)	
		C	
		(for other ESA)	

"

Paragraph 6.10.3., amend to read:

"6.10.3. ESAs with no immunity related functions need not be tested for immunity to radiated disturbances and shall be deemed to comply with paragraph ~~6.7.~~ **6.8.** and with Annex 9 to this Regulation."

Paragraph 6.10.5., amend to read:

"6.10.5. Emission of transient conducted disturbances generated by ESAs on **12/24 V** supply lines
ESAs that are not switched, contain no switches or do not include inductive load need not be tested for transient conducted emission and shall be deemed to comply with paragraph ~~6.9.~~ **6.7.**"

Paragraphs 7. to 7.1.1., amend to read:

"7. Additional specifications in the configuration "**REESS** charging mode coupled to the power grid

7.1. General specifications

7.1.1. A vehicle and its electrical/electronic system(s) **or ESA(s)** shall be so designed, constructed and fitted as to enable the vehicle, in configuration "**REESS** charging mode coupled to the power grid", to comply with the requirements of this Regulation."

Paragraph 7.1.2., renumber as 7.1.1.1. and amend to read:

"**7.1.1.1.** A vehicle in configuration "**REESS** charging mode coupled to the power grid" shall be tested for radiated emissions, immunity to radiated disturbances, conducted emissions and immunity to conducted disturbances."

Insert new paragraph 7.1.1.2., to read:

"7.1.1.2. ESAs in configuration "REESS charging mode coupled to the power grid" shall be tested for radiated and conducted emissions, for immunity to radiated and conducted disturbances."

Paragraph 7.1.3., renumber as paragraph 7.1.2. and amend to read:

"7.1.2. Before testing the Technical Service has to prepare a test plan in conjunction with the manufacturer, for the configuration "REESS charging mode coupled to the power grid" configuration which contains at least mode of operation, stimulated function(s), monitored function(s), pass/fail criterion (criteria) and intended emissions."

Insert new paragraphs 7.1.3. and 7.1.4., to read:

"7.1.3. A vehicle in configuration "REESS charging mode coupled to the power grid" should be tested with the charging cable delivered by the manufacturer. In this case, the cable shall be type approved as part of the vehicle.

7.1.4. Artificial networks

AC Power mains shall be applied to the vehicle / ESA through 50 $\mu\text{H}/50 \Omega$ AN(s) as defined in CISPR 16-1-2 clause 4.3.

DC Power mains shall be applied to the vehicle / ESA through 5 $\mu\text{H}/50 \Omega$ AN(s) as defined in CISPR 25.

High voltage power line shall be applied to the ESA through a 5 $\mu\text{H}/50 \Omega$ HV-AN(s) as defined in appendix 8."

Paragraph 7.3.2.1., amend to read:

"7.3.2.1. If measurements are made using the method described in Annex 11, the limits for input current ≤ 16 A per phase are those defined in IEC 61000-3-2 (edition 3.2—2005 + Amd1:2008 + Amd2:2009) and given in Table 3.

Table 3

Maximum allowed harmonics (input current ≤ 16 A per phase)

<i>Harmonic number</i>	<i>Maximum authorized harmonic current</i>
<i>n</i>	<i>A</i>
Odd harmonics	
3	2.3
5	1.14
7	0.77
9	0.40
11	0.33
13	0.21
$15 \leq n \leq 39$	$0.15 \times 15/n$
Even harmonics	
2	1.08
4	0.43
6	0.30
$8 \leq n \leq 40$	$0.23 \times 8/n$

"

Paragraph 7.3.2.2., amend to read:

"7.3.2.2. If measurements are made using the method described in Annex 11, the limits for input current > 16 A and ≤ 75 A per phase are those defined in IEC 61000-3-12, (~~edition 1.0—2004~~) and given in given in ~~Table 4, 5 and 6~~ **Table 4, Table 5 and Table 6.**"

Tables 4, 5, 6 remain unchanged.

Paragraph 7.4.2.1., amend to read:

"7.4.2.1. If measurements are made using the method described in Annex 12, the limits for rated current ≤ 16 A per phase and not subjected to conditional connection are those defined in IEC 61000-3-3, (~~edition 2.0—2008~~) **clause 5 and given in Table 7.**"

Table 7, to delete.

Paragraph 7.4.2.2., amend to read:

"7.4.2.2. If measurements are made using the method described in Annex 12, the limits for rated current > 16 A and ≤ 75 A per phase and subjected to conditional connection are those defined in IEC 61000-3-11, (~~edition 1.0—2000~~) **clause 5 and given in Table 8.**"

Table 8, to delete.

Paragraphs 7.5.2.1. and 7.5.2.2., amend to read:

"7.5.2.1. If measurements are made using the method described in Annex 13, the limits on AC power lines are those defined in IEC 61000-6-3 (~~edition 2.0—2006~~) and given in Table ~~97~~.

Table ~~97~~

Maximum allowed radiofrequency conducted disturbances on AC power lines

Frequency (MHz)	Limits and detector
0.15 to 0.5	66 to 56 dB μ V (quasi-peak) 56 to 46 dB μ V (average) (linearly decreasing with logarithm of frequency)
0.5 to 5	56 dB μ V (quasi-peak) 46 dB μ V (average)
5 to 30	60 dB μ V (quasi-peak) 50 dB μ V (average)

7.5.2.2. If measurements are made using the method described in Annex 13, the limits on DC power lines are those defined in IEC 61000-6-3 (edition 2.0-2006) and given in Table 108.

Table ~~108~~

Maximum allowed radiofrequency conducted disturbances on DC power lines

Frequency (MHz)	Limits and detector
-----------------	---------------------

<i>Frequency (MHz)</i>	<i>Limits and detector</i>
0.15 to 0.5	79 dB μ V (quasi-peak) 66 dB μ V (average)
0.5 to 30	73 dB μ V (quasi-peak) 60 dB μ V (average)

"

Paragraph 7.6.2.1., amend to read:

"7.6.2.1. If measurements are made using the method described in Annex 14, the limits on network and telecommunication access (**telecommunication access as defined in clause 3.6. of CISPR22**) are those defined in IEC 61000-6-3 (~~edition 2.0-2006~~) and given in Table 449.

Table 449

Maximum allowed radiofrequency conducted disturbances on network and telecommunication access

<i>Frequency (MHz)</i>	<i>Limits and detector</i>	
	<i>Voltage limits (detector)</i>	<i>Current limits (detector)</i>
0.15 to 0.5	84 to 74 dB μ V (quasi-peak) 74 to 64 dB μ V (average) (linearly decreasing with logarithm of frequency)	40 to 30 dB μ A (quasi-peak) 30 to 20 dB μ A (average) (linearly decreasing with logarithm of frequency)
0.5 to 30	74 dB μ V (quasi-peak) 64 dB μ V (average)	30 dB μ A (quasi-peak) 20 dB μ A (average)

"

Paragraph 7.9.2.1., amend to read:

"7.9.2.1. If tests are made using the methods described in Annex 16, the immunity test levels shall be:

- for AC power lines: ± 2 kV test voltage in open circuit between line and earth and ± 1 kV between lines (**pulse 1,2 μ s / 50 μ s**), with a rise time (Tr) of 1,2 μ s, and a hold time (Th) of 50 μ s. Each surge shall be applied 5 times ~~at 1 minute delay for each of~~ **with a maximum delay of 1 minute between each pulse. This has to be applied for the** following phases: 0, 90, 180 and 270°,
- for DC power lines: $\pm 0,5$ kV test voltage in open circuit between line and earth and $\pm 0,5$ kV between lines (**pulse 1,2 μ s / 50 μ s**) with a rise time (Tr) of 1,2 μ s, and a hold time (Th) of 50 μ s. Each surge shall be applied 5 times ~~at 1 minute delay~~ **with a maximum delay of 1 minute.**

Insert new paragraphs 7.10. to 7.19., to read:

"7.10. Specifications concerning broadband electromagnetic interference caused by ESAs

7.10.1. Method of measurement

The electromagnetic radiation generated by the ESA representative of its type shall be measured by the method described in Annex 7.

7.10.2. ESA broadband type approval limits

7.10.2.1. If measurements are made using the method described in Annex 7, the limits shall be 62 to 52 dB microvolts/m in the 30 to 75 MHz frequency band, this limit decreasing logarithmically with frequencies above 30 MHz, and 52 to 63 dB microvolts/m in the 75 to 400 MHz band, this limit increasing logarithmically with frequencies above 75 MHz as shown in Appendix 6. In the 400 to 1,000 MHz frequency band the limit remains constant at 63 dB microvolts/m.

7.10.2.2. On the ESA representative of its type, the measured values, expressed in dB microvolts/m, shall be below the type approval limits.

7.11. Specifications concerning emission of harmonics on AC power lines from ESAs

7.11.1. Method of measurement

The harmonics emission on AC power lines generated by the ESA representative of its type shall be measured using the method described in Annex 17. The method of measurement shall be defined by the manufacturer in accordance with the Technical Service.

7.11.2. ESA type approval limit

7.11.2.1. If measurements are made using the method described in Annex 17, the limits for input current ≤ 16 A per phase are those defined in IEC 61000-3-2 and given in Table 10.

Table 10
Maximum allowed harmonics (input current ≤ 16 A per phase)

<i>Harmonic number</i>	<i>Maximum authorized harmonic current</i>
<i>n</i>	<i>A</i>
<i>Odd harmonics</i>	
3	2,3
5	1.14
7	0.77
9	0.40
11	0.33
13	0.21
$15 \leq n \leq 39$	$0.15 \times 15/n$
<i>Even harmonics</i>	
2	1.08
4	0.43
6	0.30
$8 \leq n \leq 40$	$0.23 \times 8/n$

- 7.11.2.2. If measurements are made using the method described in Annex 17, the limits for input current > 16 A and ≤ 75 A per phase are those defined in IEC 61000-3-12 and given in Table 11, Table 12 and Table 13.

Table 11

Maximum allowed harmonics (input current > 16 A and ≤ 75 A per phase) for equipment other than balanced three-phase equipment

Minimum R_{scc}	Acceptable individual harmonic current I_n/I_1 %						Maximum current harmonic ratio %	
	I_3	I_5	I_7	I_9	I_{11}	I_{13}	THD	PWHD
33	21.6	10.7	7.2	3.8	3.1	2	23	23
66	24	13	8	5	4	3	26	26
120	27	15	10	6	5	4	30	30
250	35	20	13	9	8	6	40	40
≥ 350	41	24	15	12	10	8	47	47

Relative values of even harmonics lower or equal to 12 shall be lower than $16/n$ %. Even harmonics greater than 12 are taken into account in the THD and PWHD in the same way than odd harmonics.

Linear interpolation between successive values of R_{scc} is authorized.

Table 12

Maximum allowed harmonics (input current > 16 A and ≤ 75 A per phase) for balanced three-phase equipment

Minimum R_{scc}	Acceptable individual harmonic current I_n/I_1 %				Maximum current harmonic ratio %	
	I_5	I_7	I_{11}	I_{13}	THD	PWHD
33	10.7	7.2	3.1	2	13	22
66	14	9	5	3	16	25
120	19	12	7	4	22	28
250	31	20	12	7	37	38
≥ 350	40	25	15	10	48	46

Relative values of even harmonics lower or equal to 12 shall be lower than $16/n$ %. Even harmonics greater than 12 are taken into account in the THD and PWHD in the same way as odd harmonics.

Linear interpolation between successive values of R_{scc} is authorized.

Table 13

Maximum allowed harmonics (input current > 16 A and ≤ 75 A per phase) for balanced three-phase equipment under specific conditions

Minimum R_{scc}	Acceptable individual harmonic current I_n/I_1 %				Maximum current harmonic ratio %	
	I_5	I_7	I_{11}	I_{13}	THD	PWHD
33	10,7	7,2	3,1	2	13	22
≥ 120	40	25	15	10	48	46

Relative values of even harmonics lower or equal to 12 shall be lower than 16/n %. Even harmonics greater than 12 are taken into account in the THD and PWHD in the same way as odd harmonics

7.12. Specifications concerning emission of voltage changes, voltage fluctuations and flicker on AC power lines from ESAs

7.12.1. Method of measurement

The emission of voltage changes, voltage fluctuations and flicker on AC power lines generated by the ESA representative of its type shall be measured using the method described in Annex 18. The method of measurement shall be defined by the ESA manufacturer in accordance with the Technical Service.

7.12.2. ESA type approval limit

7.12.2.1. If measurements are made using the method described in Annex 18, the limits for rated current ≤ 16 A per phase and not subjected to conditional connection are those defined in IEC 61000-3-3, clause 5.

7.12.2.2. If measurements are made using the method described in Annex 18, the limits for rated current > 16 A and ≤ 75 A per phase and subjected to conditional connection are those defined in IEC 61000-3-11, clause 5.

7.13. Specifications concerning emission of radiofrequency conducted disturbances on AC or DC power lines from ESA

7.13.1. Method of measurement

The emission of radiofrequency conducted disturbances on AC or DC power lines generated by the ESA representative of its type shall be measured using the method described in Annex 19. The method of measurement shall be defined by the ESA manufacturer in accordance with the Technical Service.

7.13.2. ESA type approval limit

7.13.2.1. If measurements are made using the method described in Annex 19, the limits on AC power lines are those defined in IEC 61000-6-3 and given in Table 14.

Table 14

Maximum allowed radiofrequency conducted disturbances on AC power lines

Frequency (MHz)	Limits and detector
0.15 to 0.5	66 to 56 dB μ V (quasi-peak) 56 to 46 dB μ V (average) (linearly decreasing with logarithm of frequency)

<i>Frequency (MHz)</i>	<i>Limits and detector</i>
0.5 to 5	56 dBμV (quasi-peak) 46 dBμV (average)
5 to 30	60 dBμV (quasi-peak) 50 dBμV (average)

7.13.2.2. If measurements are made using the method described in Annex 19, the limits on DC power lines are those defined in IEC 61000-6-3 and given in Table 15.

Table 15

Maximum allowed radiofrequency conducted disturbances on DC power lines

<i>Frequency (MHz)</i>	<i>Limits and detector</i>
0.15 to 0.5	79 dBμV (quasi-peak) 66 dBμV (average)
0.5 to 30	73 dBμV (quasi-peak) 60 dBμV (average)

7.14. Specifications concerning emission of radiofrequency conducted disturbances on network and telecommunication access from ESA

7.14.1. Method of measurement

The emission of radiofrequency conducted disturbances on network and telecommunication access generated by the ESA representative of its type shall be measured using the method described in Annex 20. The method of measurement shall be defined by the ESA manufacturer in accordance with the Technical Service.

7.14.2. ESA type approval limit

7.14.2.1. If measurements are made using the method described in Annex 20, the limits on network and telecommunication access (telecommunication access as defined in Clause 3.6 of CISPR22) are those defined in IEC 61000-6-3 and given in Table 16.

Table 16

Maximum allowed radiofrequency conducted disturbances on network and telecommunication access

<i>Frequency (MHz)</i>	<i>Voltage limits (detector)</i>	<i>Current limits (detector)</i>
0,15 to 0,5	84 to 74 dBμV (quasi-peak) 74 to 64 dBμV (average) (linearly decreasing with logarithm of frequency)	40 to 30 dBμA (quasi-peak) 30 to 20 dBμA (average) (linearly decreasing with logarithm of frequency)
0,5 to 30	74 dBμV (quasi-peak) 64 dBμV (average)	30 dBμA (quasi-peak) 20 dBμA (average)

7.15. Specifications concerning the immunity of ESAs to electrical fast transient/burst disturbances conducted along AC and DC power lines

7.15.1. Method of testing

- 7.15.1.1. The immunity to electrical fast transient/burst disturbances conducted along AC and DC power lines of the ESA representative of its type shall be tested by the method described in Annex 21.
- 7.15.2. ESA immunity type approval limits
- 7.15.2.1. If tests are made using the methods described in Annex 21, the immunity test levels, for AC or DC power lines, shall be : ± 2 kV test voltage in open circuit, with a rise time (Tr) of 5 ns, and a hold time (Th) of 50 ns and a repetition rate of 5 kHz for at least 1 minute.
- 7.15.2.2. The ESA representative of its type shall be considered as complying with immunity requirements if, during the tests performed in accordance with Annex 15, there shall be no degradation of performance of "immunity related functions", according to paragraph 2.2. of Annex 9.
- 7.16. Specifications concerning the immunity of ESAs to surge conducted along AC or DC power lines
- 7.16.1. Method of testing
- 7.16.1.1. The immunity to surge conducted along AC / DC power lines of the ESA representative of its type shall be tested by the method described in Annex 22.
- 7.16.2. ESA immunity type approval limits
- 7.16.2.1. If tests are made using the methods described in Annex 22, the immunity test levels shall be:
- (a) for AC power lines: ± 2 kV test voltage in open circuit between line and earth and ± 1 kV between lines (pulse 1,2 μ s / 50 μ s), with a rise time (Tr) of 1,2 μ s, and a hold time (Th) of 50 μ s. Each surge shall be applied 5 times with a maximum delay of 1 minute between each pulse. This has to be applied for the following phases: 0, 90, 180 and 270°,
- (b) for DC power lines: $\pm 0,5$ kV test voltage in open circuit between line and earth and $\pm 0,5$ kV between lines (pulse 1,2 μ s / 50 μ s) with a rise time (Tr) of 1,2 μ s, and a hold time (Th) of 50 μ s. Each surge shall be applied 5 times with a maximum delay of 1 minute.
- 7.16.2.2. The ESA representative of its type shall be considered as complying with immunity requirements if, during the tests performed in accordance with Annex 22, there shall be no degradation of performance of "immunity related functions", according to paragraph 2.2. of Annex 9.
- 7.17. Specifications concerning the emission of transient conducted disturbances generated by ESAs on 12/ 24 V supply lines
- 7.17.1. Method of testing
- The emission of ESA representative of its type shall be tested by the method(s) according to *ISO 7637-2*, as described in Annex 10 for the levels given in Table 17.

Table 17

Maximum allowed pulse amplitude

Maximum allowed pulse amplitude for

<i>Maximum allowed pulse amplitude for</i>		
<i>Polarity of pulse amplitude</i>	<i>Vehicles with 12 V systems</i>	<i>Vehicles with 24 V systems</i>
Positive	+75	+150
Negative	-100	-450

7.18. Specifications concerning immunity of ESAs to electromagnetic radiation

7.18.1. Method(s) of testing

The immunity to electromagnetic radiation of the ESA representative of its type shall be tested by the method(s) chosen from those described in Annex 9.

7.18.2. ESA immunity type approval limits

7.18.2.1. If tests are made using the methods described in Annex 9, the immunity test levels shall be 60 volts/m rms for the 150 mm stripline testing method, 15 volts/m rms for the 800 mm stripline testing method, 75 volts/m rms for the Transverse Electromagnetic Mode (TEM) cell testing method, 60 mA rms for the bulk current injection (BCI) testing method and 30 volts/m rms for the free field testing method in over 90 per cent of the 20 to 2,000 MHz frequency band, and to a minimum of 50 volts/m rms for the 150 mm stripline testing method, 12.5 volts/m rms for the 800 mm stripline testing method, 62.5 volts/m rms, for the TEM cell testing method, 50 mA rms for the bulk current injection (BCI) testing method and 25 volts/m rms for the free field testing method over the whole 20 to 2,000 MHz frequency band.

7.18.2.2. The ESA representative of its type shall be considered as complying with immunity requirements if, during the tests performed in accordance with Annex 9, there shall be no degradation of performance of "immunity related functions".

7.19. Specifications concerning the immunity of ESAs to transient disturbances conducted along 12/ 24 V supply lines.

7.19.1 Method of testing

The immunity of ESA representative of its type shall be tested by the method(s) according to *ISO 7637-2*, as described in Annex 10 with the test levels given in Table 18.

Table 18

Immunity of ESA

<i>Test pulse number</i>	<i>Immunity test level</i>	<i>Functional status for systems:</i>	
		<i>Related to immunity related functions</i>	<i>Not related to immunity related functions</i>
1	III	C	D
2a	III	B	D

<i>Test pulse number</i>	<i>Immunity test level</i>	<i>Functional status for systems:</i>	
		<i>Related to immunity related functions</i>	<i>Not related to immunity related functions</i>
2b	III	C	D
3a/3b	III	A	D
4	III	B	D
		(for ESA which must be operational during engine start phases)	
		C	
		(for other ESA)	

Paragraph 7.10. renumber as 7.20.

Insert new paragraph 7.20.1, to read:

"7.20.1. When there is no direct connection to a telecommunication network which includes telecommunication service additional to the charging communication service, Annex 14 and Annex 20 shall not apply."

Paragraph 7.10.1., renumber as 7.20.2.

Insert new paragraphs 7.20.3. to 7.20.5., to read:

"7.20.3. When network and telecommunication access of the ESA uses Power Line Transmission (PLT) on its AC/DC power lines, Annex 20 shall not apply.

7.20.4. Vehicles and / or ESA which are intended to be used in "REESS charging mode coupled to the power grid" in the configuration connected to a DC-charging station with a length of a DC network cable shorter than 30 m do not have to fulfil the requirements of Annex 13, Annex 15, Annex 16, Annex 19, Annex 21 and Annex 22.

In this case, the manufacturer must provide a statement that the vehicle and /or ESA can be used in "REESS charging mode coupled to the power grid" only with cables shorter than 30m. This information must be made publicly available following the type approval.

7.20.5. Vehicles and / or ESA which are intended to be used in "REESS charging mode coupled to the power grid" in the configuration connected to a local / private DC-charging station without additional participants do not have to fulfil requirements of Annexes 13, 15, 16, 19, 21 and 22.

In this case, the manufacturer must provide a statement that the vehicle and /or ESA can be used in "REESS charging mode coupled to the power grid" only with a local / private DC charging station without additional participants. This information must be made publicly available following the type approval."

Paragraph 8.2., amend to read:

- "8.2. Where the additional or substitutional part(s) has (have) not received approval pursuant to this Regulation, and if testing is considered necessary, the whole vehicle shall be deemed to conform if the new or revised part(s) can be shown to conform to the relevant requirements of paragraph 6 **and if applicable of paragraph 7** or if, in a comparative test, the new part can be shown not to be likely to adversely affect the conformity of the vehicle type."

Paragraph 9.1., amend to read:

- "9.1. Vehicles or components or ESAs approved under this Regulation shall be so manufactured as to conform to the type approved by meeting the requirements set forth in paragraph 6 **and if applicable in paragraph 7** above."

Paragraphs 9.3. to 9.3.3., amend to read:

- "9.3. If the Competent Authority is not satisfied with the checking procedure of the manufacturer, then paragraphs **9.3.1., 9.3.2 and 9.3.3.** below shall apply.
- 9.3.1. When the conformity of a vehicle, component or ESA taken from the series is being verified, production shall be deemed to conform to the requirements of this Regulation in relation to broadband electromagnetic disturbances and narrowband electromagnetic disturbances if the levels measured do not exceed by more ~~the~~ **than 4 dB (60 per cent)** the reference limits prescribed in paragraphs 6.2.2.1., 6.2.2.2., 6.3.2.1., 6.3.2.2. **and, if applicable, paragraphs 7.2.2.1. and 7.2.2.2 for vehicles and 6.5.2.1, 6.6.2.1, and, if applicable, 7.10.2.1 for ESAs,** (as appropriate).
- 9.3.2. When the conformity of a vehicle, component or ESA taken from the series is being verified, production shall be deemed to conform to the requirements of this Regulation in relation to immunity to electromagnetic radiation if the vehicle ESA does not exhibit any degradation relating to the direct control of the vehicle which could be observed by the driver or other road user when the vehicle is in the state defined in Annex 6, paragraph 4, and is subjected to a field strength, expressed in Volts/m, up to 80 per cent of the reference limits prescribed in paragraph 6.4.2.1., and, **if applicable, paragraph 7.7.2.1. for vehicles and paragraph 6.8.2.1 and, if applicable, paragraph 7.18.2.1 for ESAs above.**
- 9.3.3. If the conformity of a component, or Separate Technical Unit (STU) taken from the series is being verified, production shall be deemed to conform to the requirements of this Regulation in relation to immunity to conducted disturbances and emission if the component or STU shows no degradation of performance of "immunity related functions" up to levels given in paragraph **6.9.1. and, if applicable, paragraph 7.19.1.,** and does not exceed the levels given in paragraph **6.7.1. and, if applicable, paragraph 7.17.1."**

Paragraph 10.1., amend to read:

- "10.1. The approval granted in respect of a type of vehicle, component or separate technical unit pursuant to this Regulation may be withdrawn if the requirements laid down in paragraph **6 and if applicable 7** above are not complied with or if the selected vehicles fail to pass the tests provided for in paragraph **6 and if applicable 7** above."

Paragraph 13, Transitional Provisions, amend to read:

Paragraph 13.1., amend to read:

13.1. General

Former paragraphs 13.1. and 13.5. combined to new paragraph 13.1.1., to read:

"13.1.1. As from the official date of entry into force of the most recent series of amendments, no Contracting Party applying this Regulation shall refuse to grant approval under this Regulation as amended by these most recent series of amendments."

Insert new paragraph 13.1.2., to read:

"13.1.2. Notwithstanding paragraphs 13.3.1. to 13.4.4., approvals granted to the preceding series of amendments to the Regulation for vehicle type which are not equipped with a coupling system to charge the REESS, or for component or separate technical unit which doesn't include a coupling part to charge the REESS, shall remain valid and Contracting Parties applying this Regulation shall continue to accept them."

Insert new paragraph 13.2., to read:

"13.2. Transitional provisions applicable to 03 series of amendments."

Paragraph 13.2., amend to read:

"13.2.1. As from 11 July 2009 (12 months after the date of entry into force of this Regulation, as amended by the 03 series of amendments), Contracting Parties applying this Regulation shall grant approvals only if the vehicle type, component or separate technical unit to be approved meets the requirements of this Regulation as amended by the 03 series of amendments."

Renumber paragraphs 13.3. to 13.2.2.

Paragraph 13.4., amend to read:

"13.2.3. Starting 11 July 2012 (48 months after the entry into force of the 03 series of amendments to this Regulation), Contracting Parties applying this Regulation may refuse first national registration (first entry into service) of a vehicle, component or separate technical unit which does not meet the requirements of the 03 series of amendments to this Regulation."

Insert new paragraph 13.3., to read:

"13.3. Transitional provisions applicable to 04 series of amendments."

Paragraph 13.5., amend to read:

"13.3.1. As from 28 October 2014 (36 months after the official date of entry into force of this Regulation, as amended by the 04 series of amendments,) Contracting Parties applying this Regulation shall grant approvals only if the vehicle type, component or separate technical unit, to be approved meets the requirements of this Regulation as amended by the 04 series of amendments."

Insert new paragraph 13.3.2., to read:

"13.3.2. Contracting Parties applying this Regulation shall continue to grant approvals to those types of vehicles or component or separate technical unit type which comply with the requirements of this Regulation as amended by the preceding series of amendments until 28. October 2014 (during the 36 months period which follows the date of entry into force of the 04 series of amendments)."

Paragraph 13.6., amend to read:

"**13.3.3.** Until **28 October 2016** (~~36~~ **60** months after the date of entry into force of the 04 series of amendments), no Contracting Parties shall refuse national or regional **type** approval of a vehicle, **component or separate technical unit type** approved to the preceding series of amendments to this Regulation."

Paragraph 13.7., amend to read:

"**13.3.4.** As from **28. October 2016** (60, months after the date of entry into force of the 04 series of amendments), Contracting Parties **applying this Regulation** may refuse **national or regional type approval and may refuse** first registration of a vehicle **type, or first entry into service of component or separate technical unit** which does not meet the requirements of the 04 series of amendments to this Regulation."

Paragraph 13.8., delete.

Insert new paragraphs 13.4. until 13.4.4., to read:

"**13.4. Transitional provisions applicable to 05 series of amendments.**

13.4.1. As from the official date of entry into force of the 05 series of amendments, no Contracting Party applying this UN Regulation shall refuse to accept UN type approvals under this UN Regulation as amended by the 05 series of amendments.

13.4.2. As from 36 months after the date of entry into force of the 05 series of amendments, Contracting Parties applying this UN Regulation shall grant UN type approvals only if the vehicle type, component or separate technical unit, to be approved meets the requirements of this UN Regulation as amended by the 05 series of amendments.

13.4.3. Until 60 months after the date of entry into force of the 05 series of amendments to this UN Regulation, no Contracting Party applying this Regulation shall refuse national or regional type approval of a vehicle, component or separate technical unit type approved to the preceding series of amendments to this Regulation.

13.4.4. As from 60 months after the date of entry into force of the 05 series of amendments to this UN Regulation, Contracting Parties applying this Regulation shall not be obliged to accept, for the purpose of national or regional type approval, a vehicle type approved to the preceding series of amendments to this Regulation."

Appendix 2, amend to read:

"...

(See paragraphs 6.2.2.1. and 7.2.2.1. of this Regulation)"

Appendix 3, amend to read:

"...

(See paragraphs 6.2.2.2. and 7.2.2.2. of this Regulation)"

Appendix 6, amend to read:

"...

(See paragraphs 6.5.2.1. and 7.10.2.1. of this Regulation)"

Insert new Appendix 8, to read:

"Appendix 8

HV artificial network

Figure 1

HV artificial network

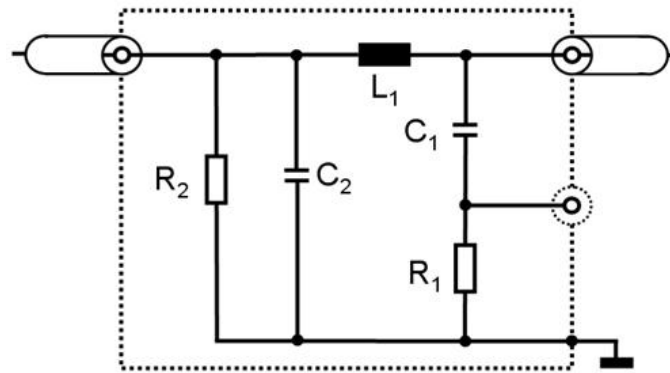

Key

$C_2: 0.1 \mu F$

$L_1: 5 \mu H$

$R_1: 1 k\Omega$

$C_1: 0.1 \mu F$

$R_2: 100 k\Omega$ (discharging C_2 to $< 50 V_{dc}$ within 60 s)

Figure 2

Impedance of HV artificial network

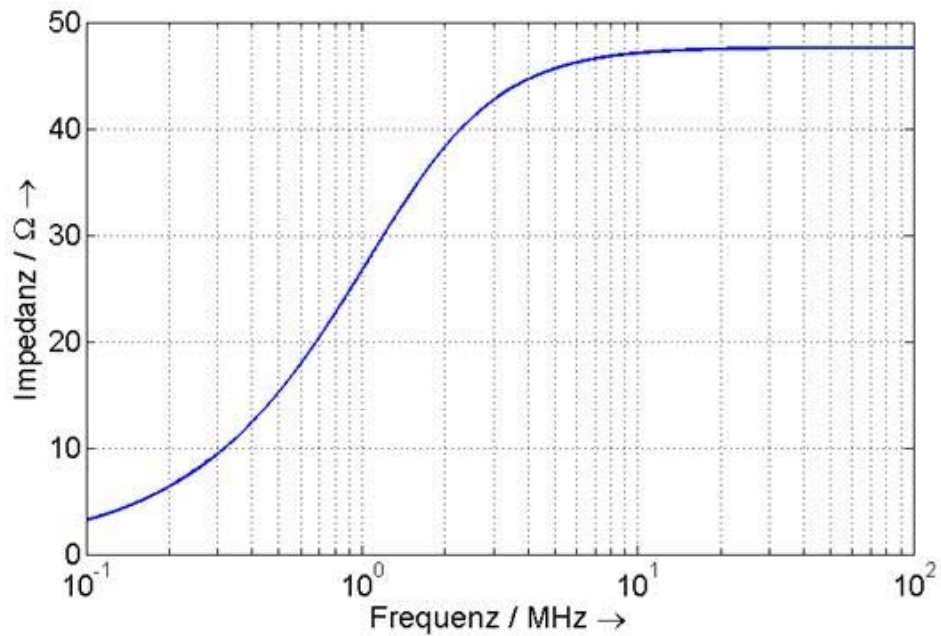
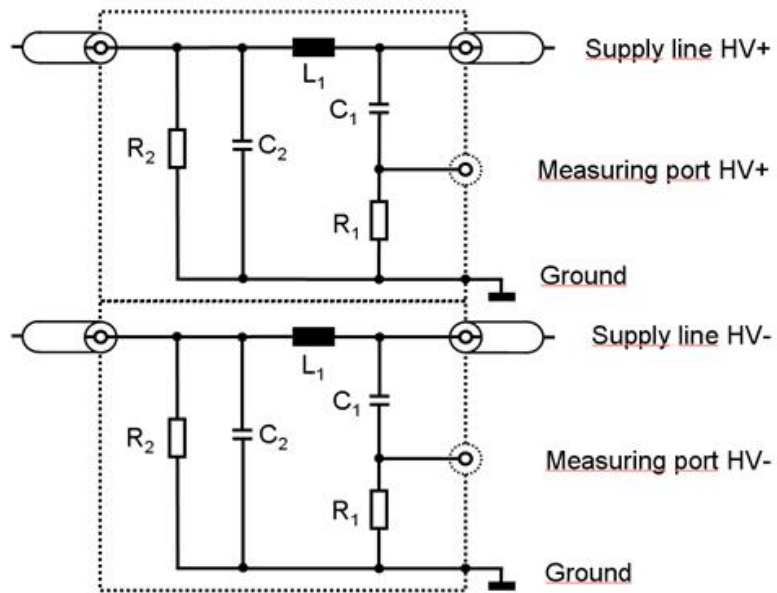

Figure 3
Combination of HV artificial network



Annex I, amend to read:

"Examples of approval marks

Model A

(See paragraph 5.2. of this Regulation)

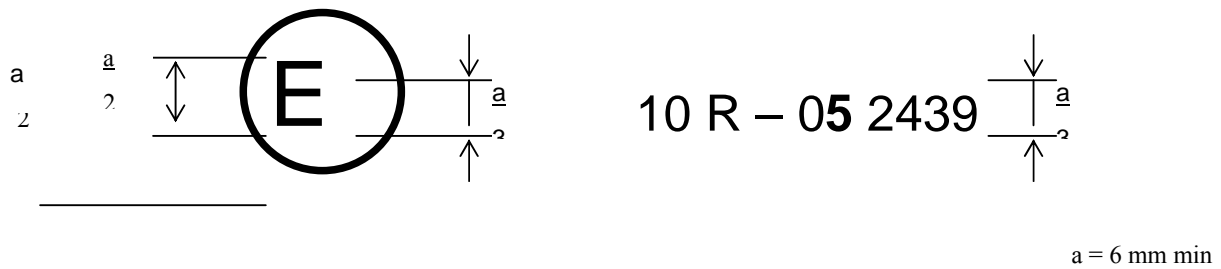

The above approval mark affixed to a vehicle or ESA shows that the vehicle type concerned has, with regard to electromagnetic compatibility, been approved in the Netherlands (E 4) pursuant to Regulation No. 10 under approval No. 052439. The approval number indicates that the approval was granted according to the requirements of Regulation No. 10 as amended by the 05 series of amendments.

Model B
(See paragraph 5.2. of this Regulation)

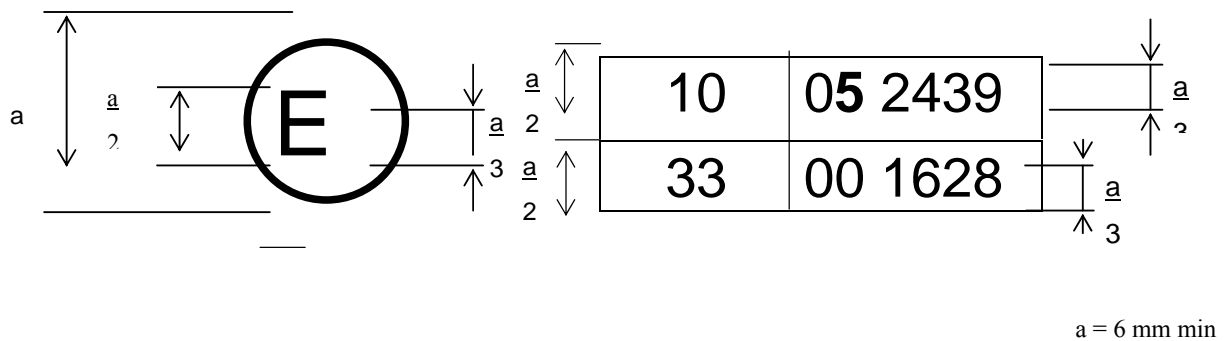

The above approval mark affixed to a vehicle or ESA shows that the vehicle type concerned has, with regard to electromagnetic compatibility, been approved in the Netherlands (E 4) pursuant to Regulations Nos. 10 and 33.¹ The approval numbers indicate that, at the date when the respective approvals were given, Regulation No. 10 included the 05 series of amendments and Regulation No. 33 was still in its original form.

Annex 2A, insert new paragraphs 70. to 72., to read:

- "70. **Minimum R_{sce} value (see chapter 7.3.)**
- 71. **Charging cable delivered with the vehicle: yes/no¹**
- 72. **If charging cable delivered with the vehicle:**
length (m)

¹ The second number is given merely as an example.

cross sectional area (mm²)..... "

Annex 2B, insert new paragraphs 10. to 15., to read:

"Only applicable for charging systems:

- 10. **Charger: on board/external¹**..... "
- 11. **Charging current: direct current/alternating current (number of phases/frequency)¹**
- 12. **Maximal nominal current (in each mode if necessary)**.....
- 13. **Nominal charging voltage**.....
- 14. **Basic ESA interface functions: ex. L1/L2/L3/N/PE/control pilot**
- 15. **Minimum Rsce value (see chapter 7.11.)**..... "

Annex 4, amend to read:

"Method of measurement of radiated broadband electromagnetic emissions from vehicles

- 1. General
 - 1.1. The test method described in this annex shall only be applied to vehicles. This method concerns both configurations of the vehicle:
 - (a) other than "REESS ~~in~~ charging mode coupled to the power grid".
 - (b) "REESS ~~in~~ charging mode coupled to the power grid"
 - 1.2. Test method

This test is intended to measure the broadband emissions generated by electrical or electronic systems fitted to the vehicle (e.g. ignition system or electric motors).

If not otherwise stated in this annex the test shall be performed according to *CISPR 12 (fifth edition 2001 and Amd1:2005)*.
- 2. Vehicle state during tests
 - 2.1. Vehicle in configuration other than "REESS ~~in~~ charging mode coupled to the power grid".
 - 2.1.1. Engine

The engine shall be in operation according to *CISPR 12 (fifth edition 2001 and Amd1:2005)*.
 - 2.1.2. Other vehicle systems

All equipment capable of generating broadband emissions which can be switched on permanently by the driver or passenger should be in operation in maximum load, e.g. wiper motors or fans. The horn and electric window motors are excluded because they are not used continuously.
 - 2.2. Vehicle in configuration "REESS ~~in~~ charging mode coupled to the power grid".

The state of charge (SOC) of the traction battery shall be kept between 20 per cent and 80 per cent of the maximum SOC during the whole

frequency range measurement (this may lead to split the measurement in different sub-bands with the need to discharge the vehicle's traction battery before starting the next sub-bands). If the current consumption can be adjusted, then the current shall be set to at least 80 per cent of its nominal value.

The test set-up for the connection of the vehicle in configuration "REESS in charging mode coupled to the power grid" is shown in Figure 3a to 3h (depending of AC or DC power charging mode, location of charging plug and charging with or without communication) of Appendix 1 to this annex.

2.3. Charging station / Power mains

The charging station may be placed either in the test location or outside the test location.

Note 1: If the communication between the vehicle and the charging station could be simulated, the charging station may be replaced by the supply from power mains.

In both case duplicated power mains and communication lines socket(s) shall be placed in the test location with the following conditions:

- It shall be placed on the ground plane.
- The length of the harness between the power mains / communication lines socket and the AN(s) / IS(s) shall be kept as short as possible.
- The harness between the power mains / communication lines socket and the AN(s) / IS(s) shall be placed as close as possible to the ground plane.

Note 2: The power mains and communication lines socket(s) should be filtered.

If the charging station is placed inside the test location then harness between charging station and the power mains / communication lines socket shall be placed with the following conditions:

- The harness at charging station side shall hang vertically down to the ground plane.
- The extraneous length shall be placed as close as possible of the ground plane and "Z-folded" if necessary.

Note 3: the charging station should be placed outside the beamwidth of the receiving antenna.

2.4. Artificial networks

The AN(s) shall be mounted directly on the ground plane. The cases of the AN(s) shall be bonded to the ground plane.

The measuring port of each AN shall be terminated with a 50 Ω load.

The AN shall be placed as defined in Figures 3a to 3h.

2.5. Impedance Stabilization

Communication lines shall be applied to the vehicle through IS(s).

The impedance stabilization (IS) to be connected in the network and communication cables is defined in CISPR 22, paragraph 9.6.2.

The IS(s) shall be mounted directly on the ground plane. The case of the IS(s) shall be bonded to the ground plane.

The measuring port of each IS shall be terminated with a 50 Ω load.

The IS shall be placed as defined in Figures 3e to 3h.

2.6 Power charging / communication cable

The power charging / communication cable shall be placed in a straight line between the AN(s) / IS(s) and the vehicle charging plug. The projected cable length shall be 0.8 (+0.2 / -0) m.

If the length of the cable is longer than 1 m, the extraneous length shall be “Z-folded” in less than 0.5 m width.

The charging / communication cable at vehicle side shall hang vertically at a distance of 100 (+200 / -0) mm from the vehicle body.

The whole cable shall be placed on a non-conductive, low relative permittivity (dielectric-constant) material ($\epsilon_r \leq 1.4$), at (100 mm \pm 25) mm above the ground plane.

3. Measuring location

3.1. As an alternative to the requirements of CISPR 12 (~~fifth edition 2001 and Amd1:2005~~) for vehicles of category L the test surface may be any location that fulfils the conditions shown in the Figure in the appendix to this annex. In this case the measuring equipment must lie outside the part shown in the Figure of Appendix 1 to this annex.

3.2. Enclosed test facilities may be used if correlation can be shown between the results obtained in the enclosed test facility and those obtained at an outdoor site. Enclosed test facilities do not need to meet the dimensional requirements of the outdoor site other than the distance from the antenna to the vehicle and the height of the antenna.

4. Test requirements

4.1. The limits apply throughout the frequency range 30 to 1,000 MHz for measurements performed in a semi anechoic chamber or an outdoor test site.

4.2. Measurements can be performed with either quasi-peak or peak detectors. The limits given in paragraphs 6.2. and 6.5. of this Regulation are for quasi-peak detectors. If peak detectors are used a correction factor of 20 dB as defined in CISPR 12 (~~fifth edition 2001 and Amd1:2005~~) shall be applied.

4.3. **The measurements shall be performed with a spectrum analyser or a scanning receiver. The parameters to be used are defined in Table 1 and Table 2.**

Table 1
Spectrum analyser parameters

Frequency range MHz	Peak detector		Quasi-peak detector		Average detector	
	RBW at -3 dB	Scan time	RBW at -6 dB	Scan time	RBW at -3 dB	Scan time

Frequency range MHz	Peak detector		Quasi-peak detector		Average detector	
	RBW at -3 dB	Scan time	RBW at -6 dB	Scan time	RBW at -3 dB	Scan time
30 to 1 000	100/120 kHz	100 ms/MHz	120 kHz	20 s/MHz	100/120 kHz	100 ms/MHz

Note: If a spectrum is used for peak measurements, the video bandwidth shall be at least three times the resolution bandwidth (RBW)

Table 2
Scanning receiver parameters

Frequency range MHz	Peak detector			Quasi-peak detector			Average detector		
	BW at -6 dB	Step size ^a	Dwell time	BW at -6 dB	Step size ^a	Dwell time	BW at -6 dB	Step size ^a	Dwell time
30 to 1 000	120 kHz	50 kHz	5 ms	120 kHz	50 kHz	1 s	120 kHz	50 kHz	5 ms

a) For purely broadband disturbances, the maximum frequency step size may be increased up to a value not greater than the bandwidth value.

4.3. 4.4. Measurements

The Technical Service shall perform the test at the intervals specified in the CISPR 12 (~~fifth edition 2001 and Amd1:2005~~) standard throughout the frequency range 30 to 1,000 MHz.

Alternatively, if the manufacturer provides measurement data for the whole frequency band from a test laboratory accredited to the applicable parts of ISO 17025 (~~second edition 2005 and Corrigendum:2006~~) and recognized by the Approval Authority, the Technical Service may divide the frequency range in 14 frequency bands 30 – 34, 34 – 45, 45 – 60, 60 – 80, 80 – 100, 100 – 130, 130 – 170, 170 – 225, 225 – 300, 300–400, 400 – 525, 525 – 700, 700 – 850, 850 – 1,000 MHz and perform tests at the 14 frequencies giving the highest emission levels within each band to confirm that the vehicle meets the requirements of this annex.

In the event that the limit is exceeded during the test, investigations shall be made to ensure that this is due to the vehicle and not to background radiation.

4.4. 4.5. Readings

The maximum of the readings relative to the limit (horizontal and vertical polarization and antenna location on the left and right-hand sides of the vehicle) in each of the 14 frequency bands shall be taken as the characteristic reading at the frequency at which the measurements were made."

Annex 4, Appendix, amend to read:

"Annex 4 – Appendix

Figure 1

Clear horizontal surface free of electromagnetic reflection delimitation of the surface defined by an ellipse

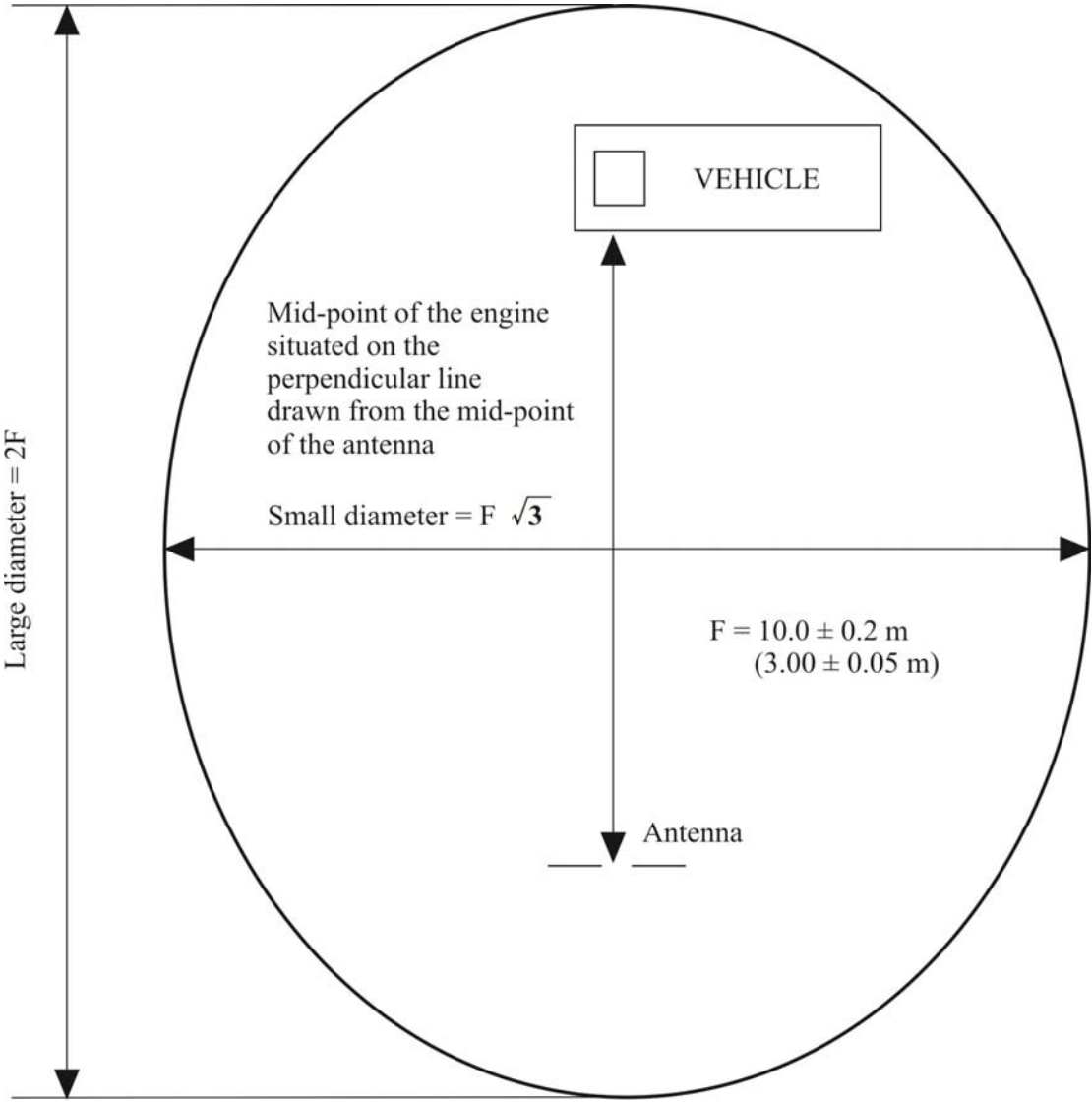
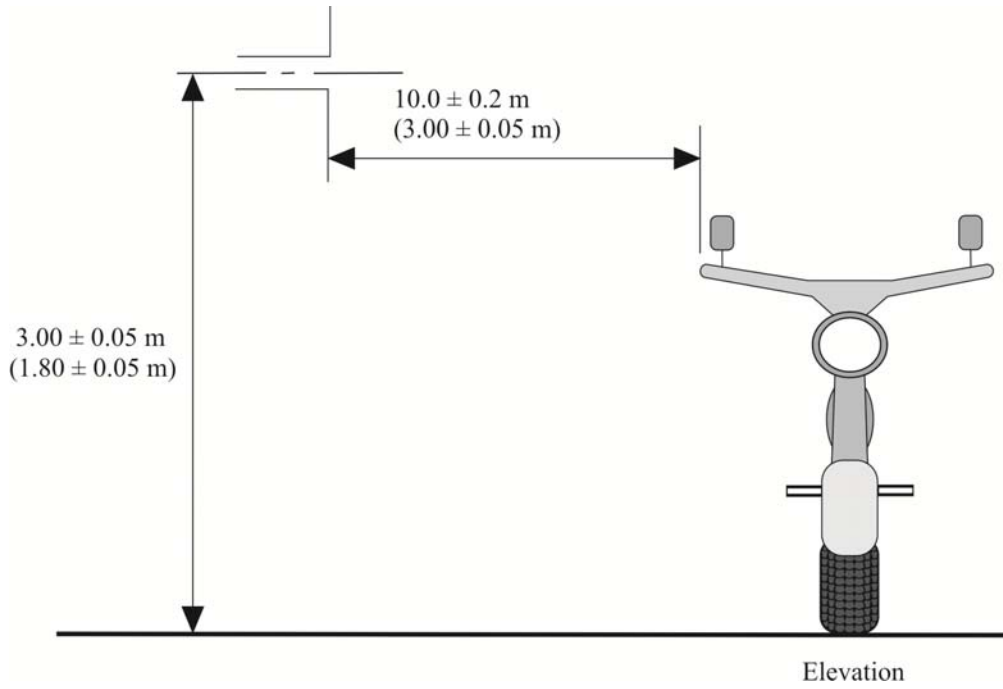

Figure 2

Position of antenna in relation to the vehicle

Dipole antenna in position to measure the vertical radiation components



Dipole antenna in position to measure the horizontal radiation components

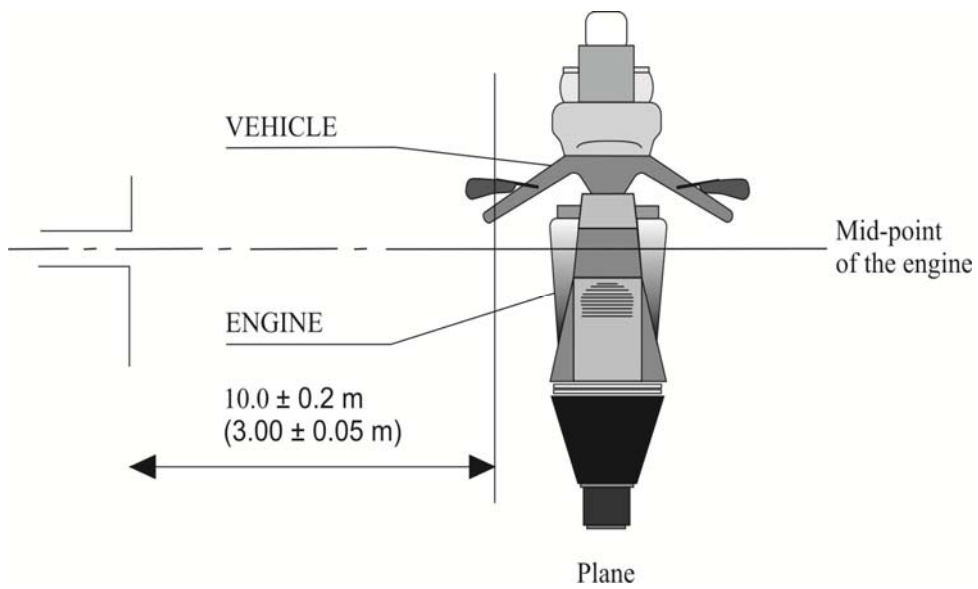
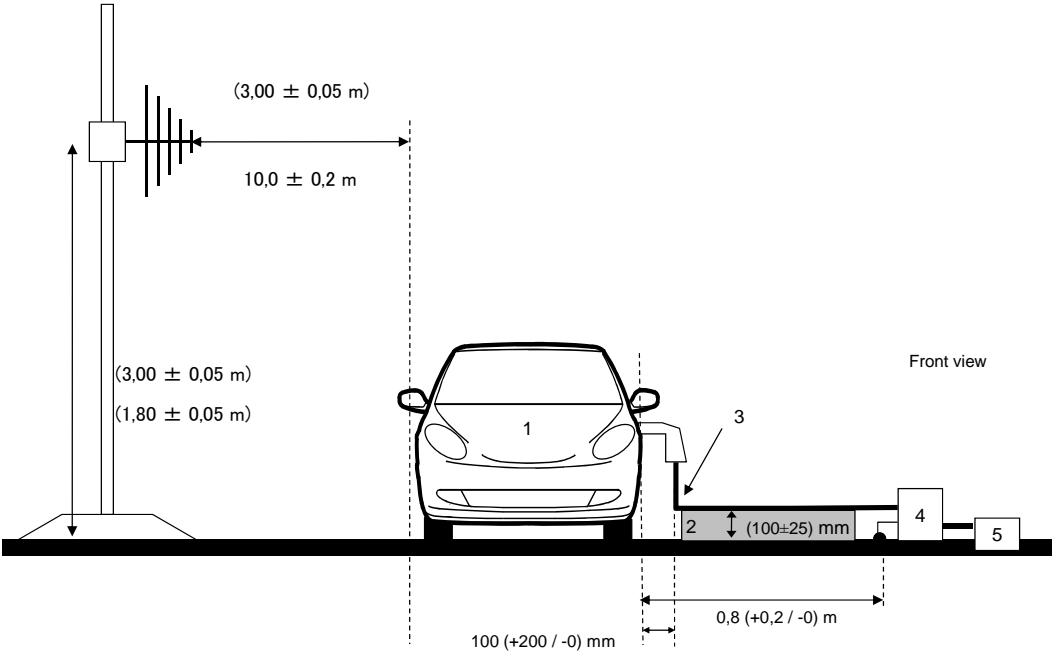
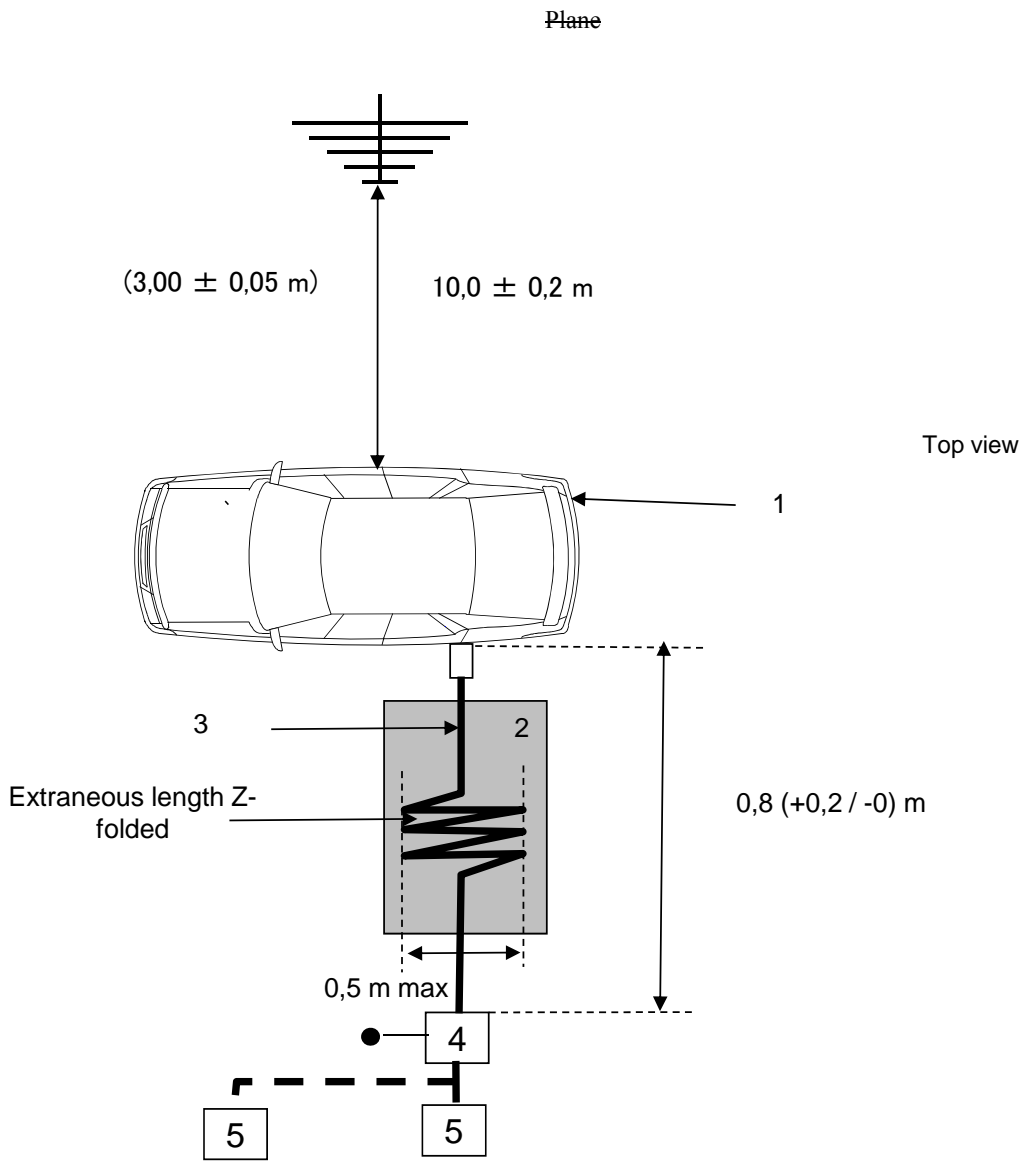

Figure 3
Vehicle in configuration "REESS charging mode" coupled to the power grid

Elevation





Key

- 1 Vehicle under test
- 2 Insulating support
- 3 Charging cable
- 4 Artificial Network(s) grounded
- 5 Power mains socket

Figures 3a & 3b - Example of test setup for vehicle with plug located on vehicle side (AC powered without communication)

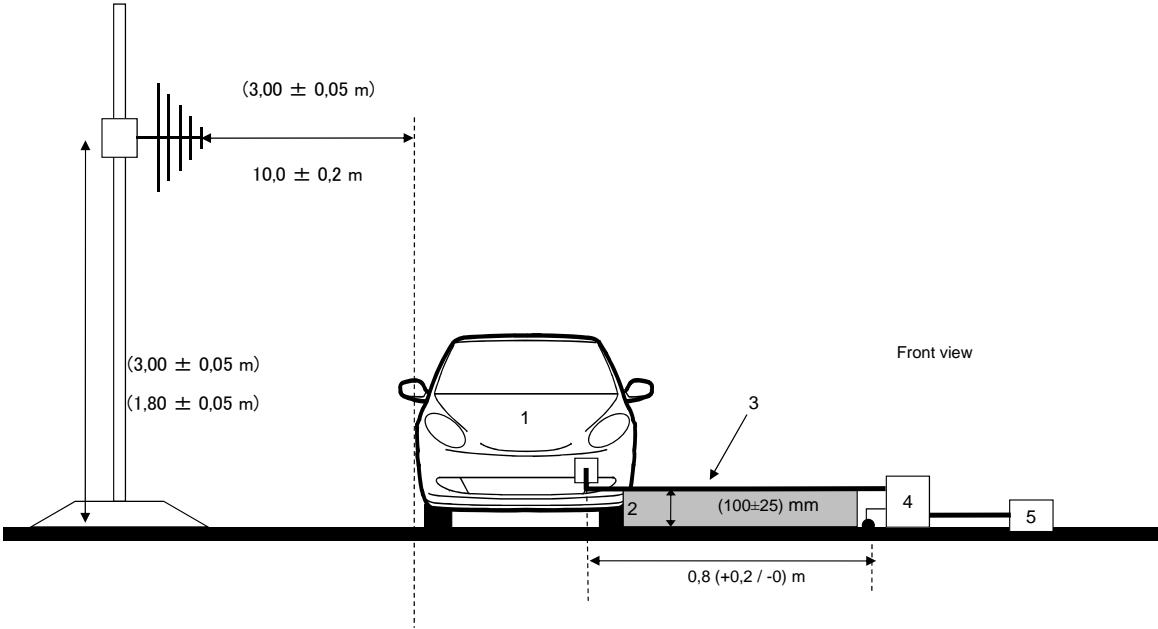

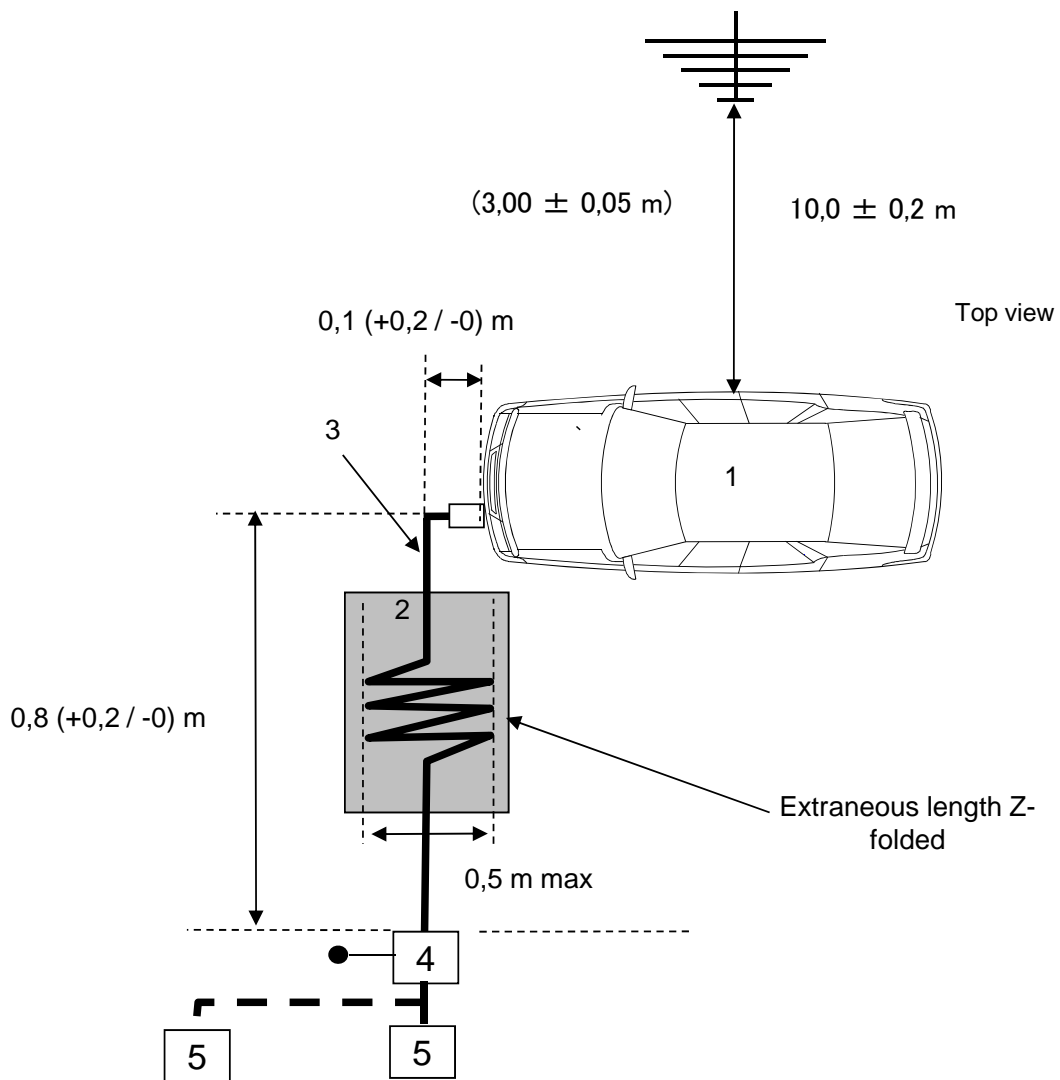

Key

- 1 Vehicle under test
- 2 Insulating support
- 3 Charging cable
- 4 Artificial Network(s) grounded
- 5 Power mains socket

Figures 3c & 3d - Example of test setup for vehicle with plug located front/rear of vehicle (AC powered without communication)

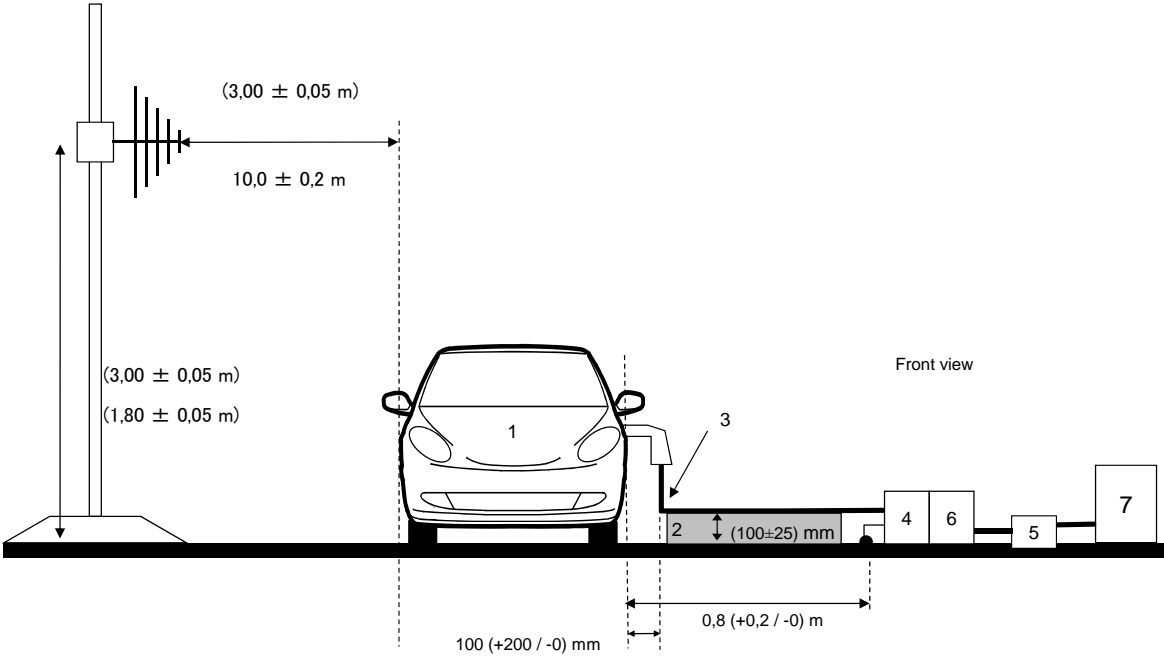

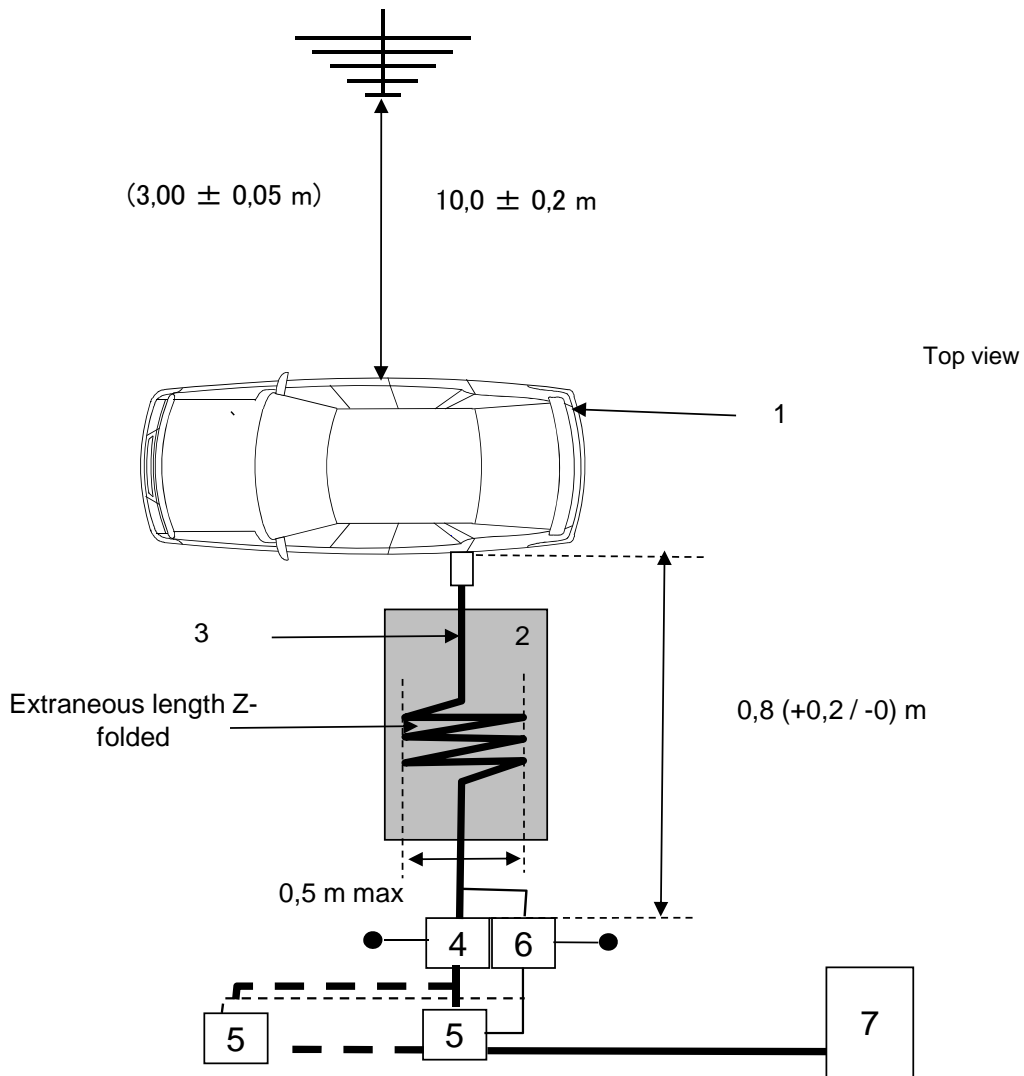

Key

- 1 Vehicle under test
- 2 Insulating support
- 3 Charging / communication cable
- 4 AC or DC Artificial Network(s) grounded
- 5 Power mains socket
- 6 Impedance Stabilisation(s) grounded
- 7 Charging Station

Figures 3e & 3f - Example of test setup for vehicle with plug located on vehicle side (AC or DC powered with communication)

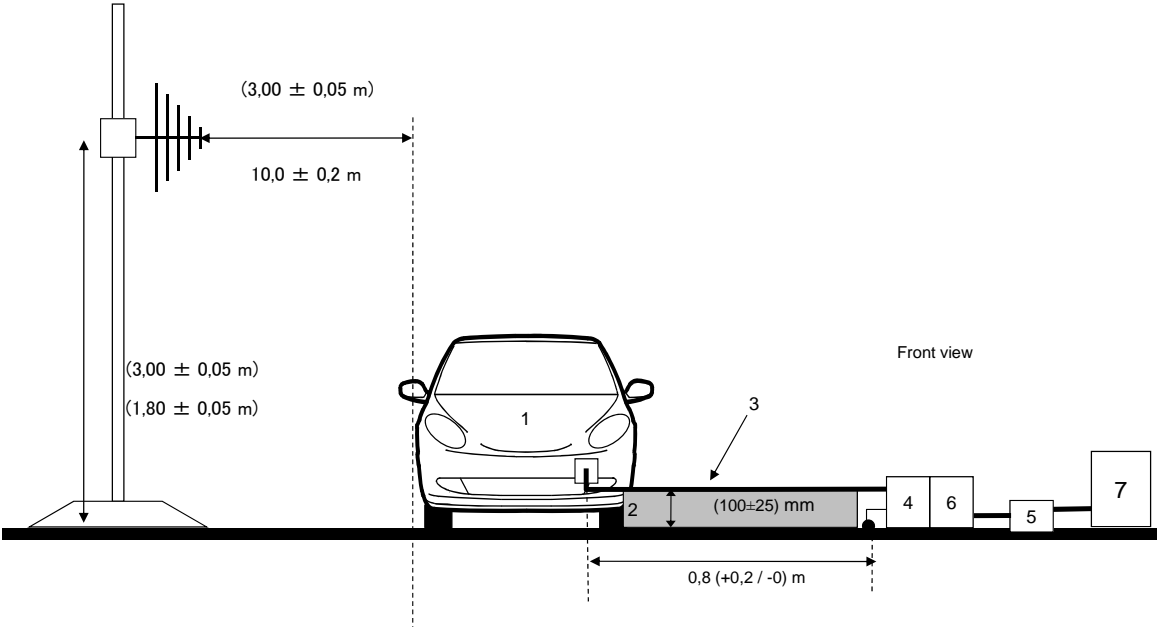

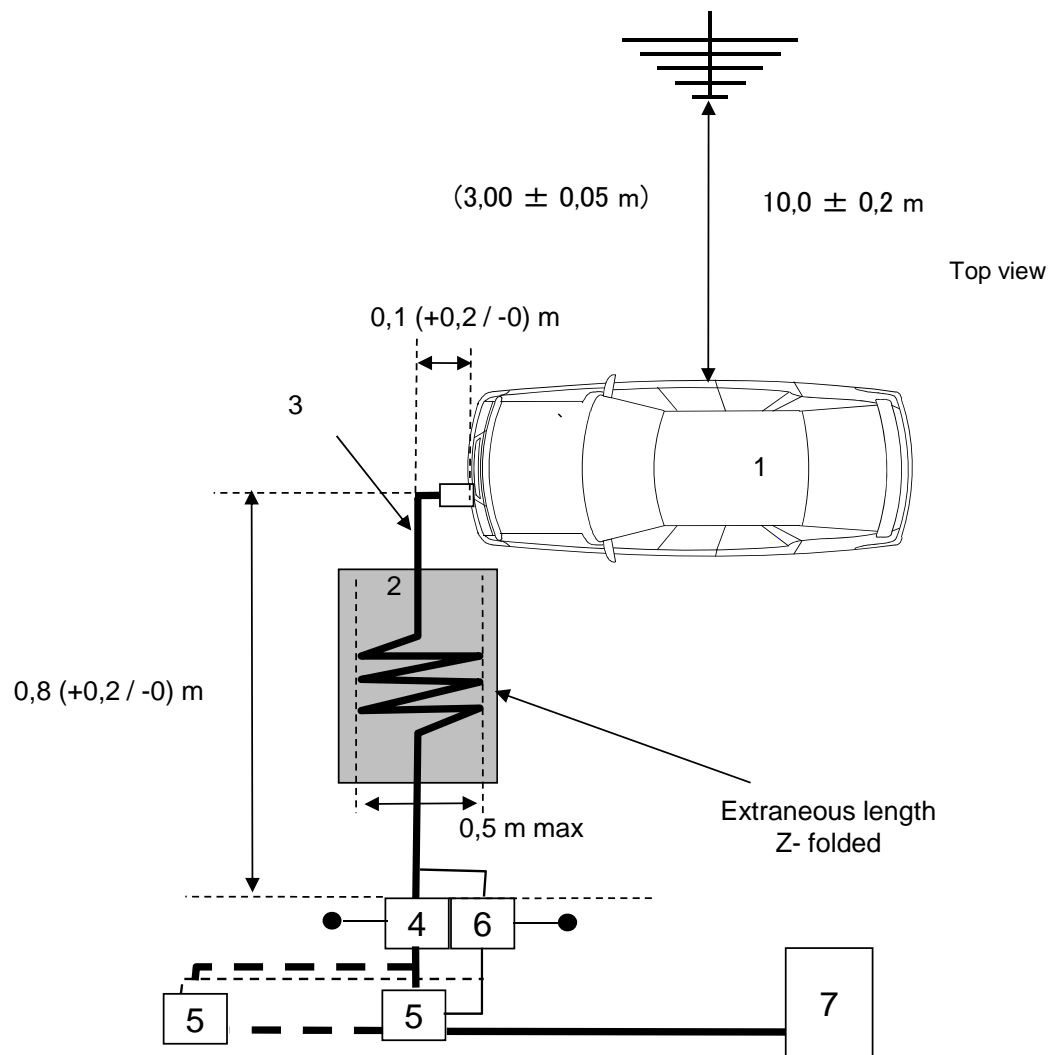

Key

- 1 Vehicle under test
- 2 Insulating support
- 3 Charging / communication cable
- 4 AC or DC Artificial Network(s) grounded
- 5 Power mains socket
- 6 Impedance Stabilisation(s) grounded
- 7 Charging Station

Figures 3g & 3h - Example of test setup for vehicle with plug located front/rear of the vehicle (AC or DC powered with communication)"

Annex 5, paragraphs 1. to 1.2., amend to read:

- "1. General
- 1.1. The test method described in this annex shall only be applied to vehicles. This method concerns only the configuration of the vehicle other than "REESS in charging mode coupled to the power grid".
- 1.2. Test method
- This test is intended to measure the narrowband electromagnetic emissions such as might emanate from microprocessor-based systems or other narrowband source.
- If not otherwise stated in this annex the test shall be performed according to *CISPR 12 (fifth edition 2001 and Amd1:2005)* or to *CISPR 25 (and corrigendum 2004)*."

Annex 5, insert new paragraph 3.3., to read:

- "3.3. The measurements shall be performed with a spectrum analyser or a scanning receiver. The parameters to be used are defined in Table 1 and Table 2.

Table 1
Spectrum analyser parameters

Frequency range MHz	Peak detector		Quasi-peak detector		Average detector	
	RBW at -3 dB	Scan time	RBW at -6 dB	Scan time	RBW at -3 dB	Scan time
30 to 1 000	100/120 kHz	100 ms/MHz	120 kHz	20 s/MHz	100/120 kHz	100 ms/MHz

Note: If a spectrum is used for peak measurements, the video bandwidth shall be at least three times the resolution bandwidth (RBW)

Table 2
Scanning receiver parameters

Frequency range MHz	Peak detector			Quasi-peak detector			Average detector		
	BW at -6 dB	Step size ^a	Dwell time	BW at -6 dB	Step size ^a	Dwell time	BW at -6 dB	Step size ^a	Dwell time
30 to 1 000	120 kHz	50 kHz	5 ms	120 kHz	50 kHz	1 s	120 kHz	50 kHz	5 ms

- a) For purely broadband disturbances, the maximum frequency step size may be increased up to a value not greater than the bandwidth value."

Annex 5, paragraph 3.3., renumber as 3.4. and amend to read:

- "3.4. Measurements

The Technical Service shall perform the test at the intervals specified in the CISPR 12 (~~fifth edition 2001 and Amd1:2005~~) standard throughout the frequency range 30 to 1,000 MHz.

Alternatively, if the manufacturer provides measurement data for the whole frequency band from a test laboratory accredited to the applicable parts of ISO 17025 (~~second edition 2005 and Corrigendum:2006~~) and recognized by the Approval Authority, the Technical Service may divide the frequency range in 14 frequency bands 30 – 34, 34 – 45, 45 – 60, 60 – 80, 80 – 100, 100 – 130, 130 – 170, 170 – 225, 225 – 300, 300– 400, 400 – 525, 525 – 700, 700 – 850, 850 – 1,000 MHz and perform tests at the 14 frequencies giving the highest emission levels within each band to confirm that the vehicle meets the requirements of this annex.

In the event that the limit is exceeded during the test, investigations shall be made to ensure that this is due to the vehicle and not to background radiation including broadband radiation from any ESA."

Annex 5, paragraph 3.4., renumber as paragraph 3.5.

Annex 6, paragraph 1. to 1.3., amend to read:

"1. General

1.1. The test method described in this annex shall only be applied to vehicles. This method concerns both configurations of vehicle:

- (a) other than "REESS in charging mode coupled to the power grid".
- (b) "REESS in charging mode coupled to the power grid"

1.2. Test method

This test is intended to demonstrate the immunity of the vehicle electronic systems. The vehicle shall be subject to electromagnetic fields as described in this annex. The vehicle shall be monitored during the tests.

If not otherwise stated in this annex the test shall be performed according to ISO 11451-2, ~~third edition 2005~~.

1.3. Alternative test methods

The test may be alternatively performed in an outdoor test site for all vehicles. The test facility shall comply with (national) legal requirements regarding the emission of electromagnetic fields.

If a vehicle is longer than 12 m and/or wider than 2.60 m and/or higher than 4.00 m, BCI (bulk current injection) method according to ISO 11451-4 (~~first edition 1995~~) can be used in the frequency range 20 to 2,000 MHz with levels defined in paragraph 6.78.2.1. of this Regulation."

Annex 6, paragraph 2.1., amend to read:

"2.1. Vehicle in configuration other than "REESS in charging mode coupled to the power grid."

Annex 6, paragraph 2.2., amend to read:

"2.2. Vehicle in configuration "REESS in charging mode coupled to the power grid."

Annex 6, paragraph 2.2.1.2., amend to read:

"2.2.1.2. Basic vehicle conditions

The paragraph defines minimum test conditions (as far as applicable) and failures criteria for vehicle immunity tests. Other vehicle systems, which can affect immunity related functions, must be tested in a way to be agreed between manufacturer and Technical Service.

<i>"REESS in charging mode" vehicle test conditions</i>	<i>Failure criteria</i>
The REESS shall be in charging mode. The REESS state of charge shall be agreed in between the manufacturer and the Technical Service (SOC) shall be kept between 20 per cent and 80 per cent of the maximum SOC during the whole frequency range measurement (this may lead to split the measurement in different sub-bands with the need to discharge the vehicle's traction battery before starting the next sub-bands). If the current consumption can be adjusted, then the current shall be set to at least 20 percent of its nominal value.	Vehicle sets in motion.
"	

Annex 6, insert new paragraphs 2.2.3. to 2.6., to read:

"2.2.3. The test set-up for the connection of the vehicle in configuration "REESS ~~in~~ charging mode coupled to the power grid" is shown in Figure 4a to 4h (depending of AC or DC power charging mode, location of charging plug and charging with or without communication) of Appendix 1 to this annex.

2.3. Charging station / Power mains

The charging station may be placed either in the test location or outside the test location.

Note 1: If the communication between the vehicle and the charging station could be simulated, the charging station may be replaced by the supply from power mains.

In both case duplicated power mains and communication lines socket(s) shall be placed in the test location with the following conditions:

- (a) It shall be placed on the ground plane.
- (b) The length of the harness between the power mains / communication lines socket and the AN(s) / IS(s) shall be kept as short as possible.
- (c) The harness between the power mains / communication lines socket and the AN(s) / IS(s) shall be placed as close as possible of the ground plane.

Note 2: The power mains and communication lines socket(s) should be filtered.

If the charging station is placed inside the test location then harness between charging station and the power mains / communication lines socket shall be placed with the following conditions:

(a) The harness at charging station side shall hang vertically down to the ground plane.

(b) The extraneous length shall be placed as close as possible of the ground plane and “Z-folded” if necessary.

Note 3: the charging station should be placed outside the beamwidth of the emitting antenna.

2.4. Artificial networks

The AN(s) shall be mounted directly on the ground plane. The cases of the AN(s) shall be bonded to the ground plane.

The measuring port of each AN shall be terminated with a 50 Ω load.

The AN shall be placed as defined in Figure 4a to 4h.

2.5. Impedance Stabilization

Communication lines shall be applied to the vehicle through IS(s).

The impedance stabilization (IS) to be connected in the network and communication cables is defined in CISPR 22 paragraph 9.6.2.

The IS(s) shall be mounted directly on the ground plane. The case of the IS(s) shall be bonded to the ground plane.

The measuring port of each IS shall be terminated with a 50 Ω load.

The IS shall be placed as defined in figure 4e to 4h.

2.6. Power charging / communication cable

The power charging / communication cable shall be placed in a straight line between the AN(s) / IS(s) and the vehicle charging plug. The projected cable length shall be 0.8 (+0.2 / -0) m.

If the length of the cable is longer than 1 m, the extraneous length shall be “Z-folded” in less than 0.5 m width.

The charging / communication cable at vehicle side shall hang vertically at a distance of 100 (+200 / -0) mm from the vehicle body.

The whole cable shall be placed on a non-conductive, low relative permittivity (dielectric-constant) material ($\epsilon_r \leq 1,4$), at (100 mm ± 25) mm above the ground plane."

Annex 6, paragraph 3.2., amend to read:

"3.2. For category M, N, O vehicles according to ISO 11451-2, ~~third edition 2005.~~"

Annex 6, paragraph 4.1. and 4.1.1., amend to read;

"4.1. Frequency range, dwell times, polarization

The vehicle shall be exposed to electromagnetic radiation in the 20 to 2,000 MHz frequency ranges in vertical polarization.

The test signal modulation shall be:

- (a) AM (amplitude modulation), with 1 kHz modulation and 80 per cent modulation depth in the 20 to 800 MHz frequency range, and
- (b) PM (pulse modulation), ~~τ on T on~~ 577 μs, period 4,600 μs in the 800 to 2,000 MHz frequency range,

if not otherwise agreed between Technical Service and vehicle manufacturer.

Frequency step size and dwell time shall be chosen according to ISO 11451-1, ~~third edition 2005 and Amd1:2008~~.

- 4.1.1. The Technical Service shall perform the test at the intervals specified in ISO 11451-1, ~~third edition 2005 and Amd1:2008~~ throughout the frequency range 20 to 2,000 MHz.

Alternatively, if the manufacturer provides measurement to data for the whole frequency band from a test laboratory accredited to the applicable parts of ISO 17025 (~~second edition 2005 and Corrigendum:2006~~) and recognized by the Approval Authority, the Technical Service may choose a reduced number of spot frequencies in the range, e.g. 27, 45, 65, 90, 120, 150, 190, 230, 280, 380, 450, 600, 750, 900, 1,300, and 1,800 MHz to confirm that the vehicle meets the requirements of this annex.

If a vehicle fails the test defined in this annex, it must be verified as having failed under the relevant test conditions and not as a result of the generation of uncontrolled fields."

Annex 6, paragraph 5.1.1., amend to read:

- "5.1.1. The substitution method according to ISO 11451-1, ~~third edition 2005 and Amd1:2008~~ shall be used to establish the test field conditions."

Annex 6, Appendix, amend to read:

"Annex 6 – Appendix 1

Figure 1

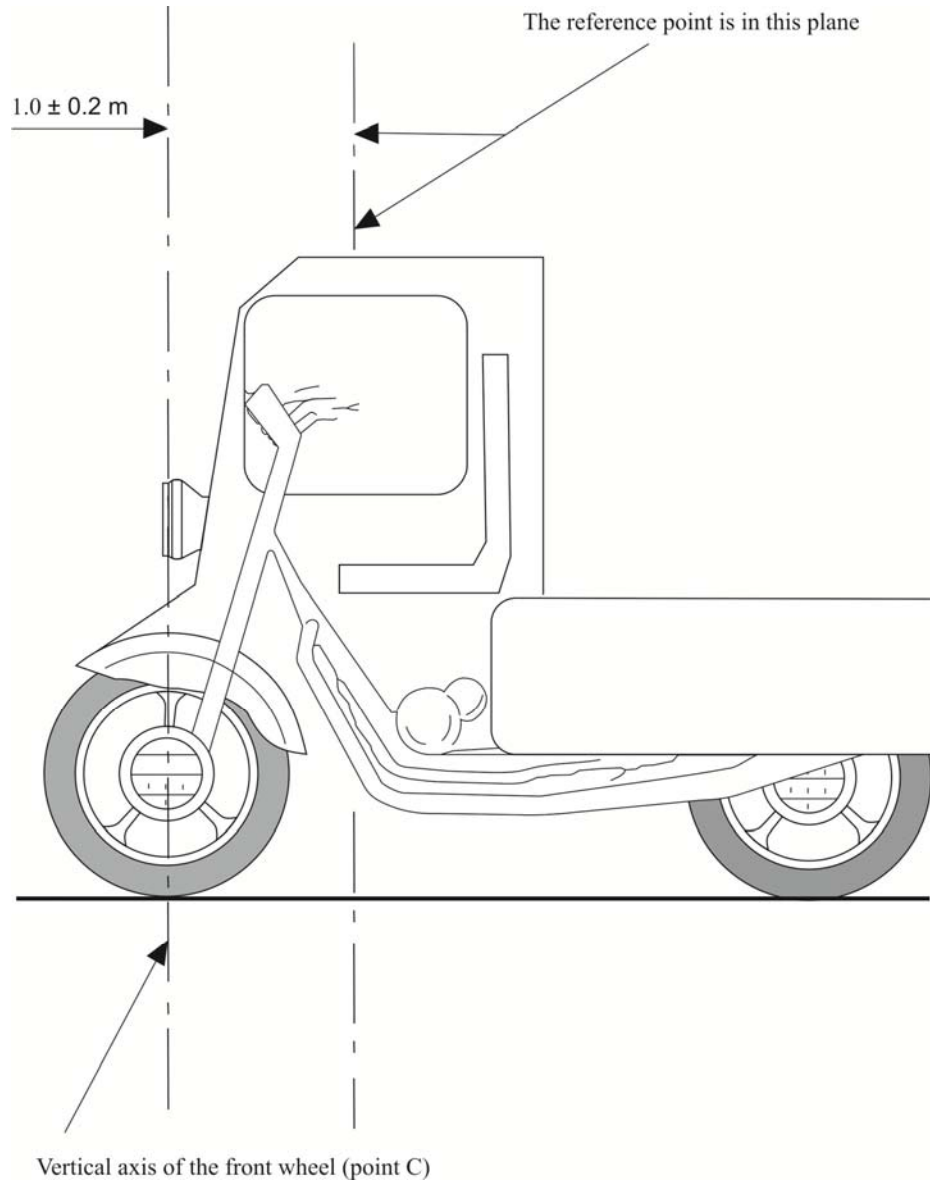

Figure 2

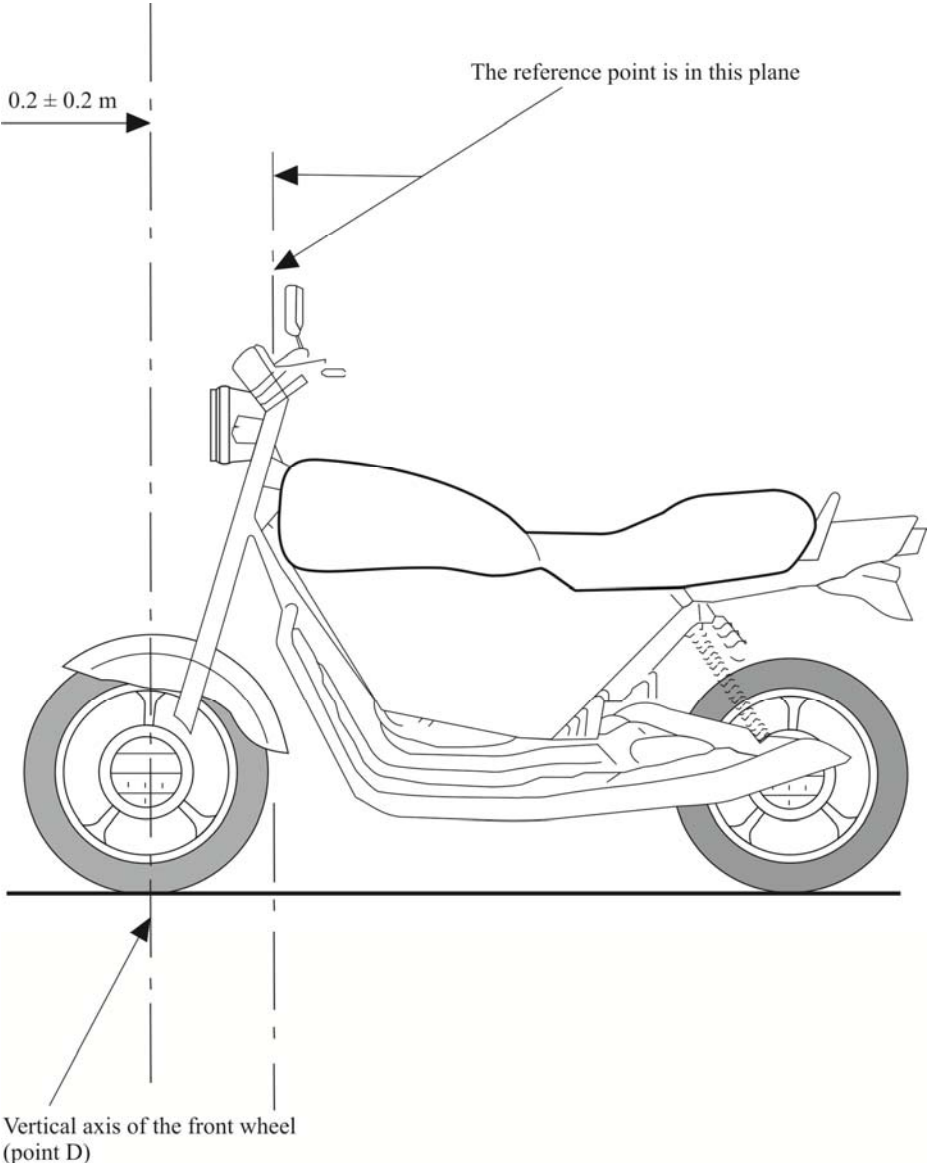

Figure 3

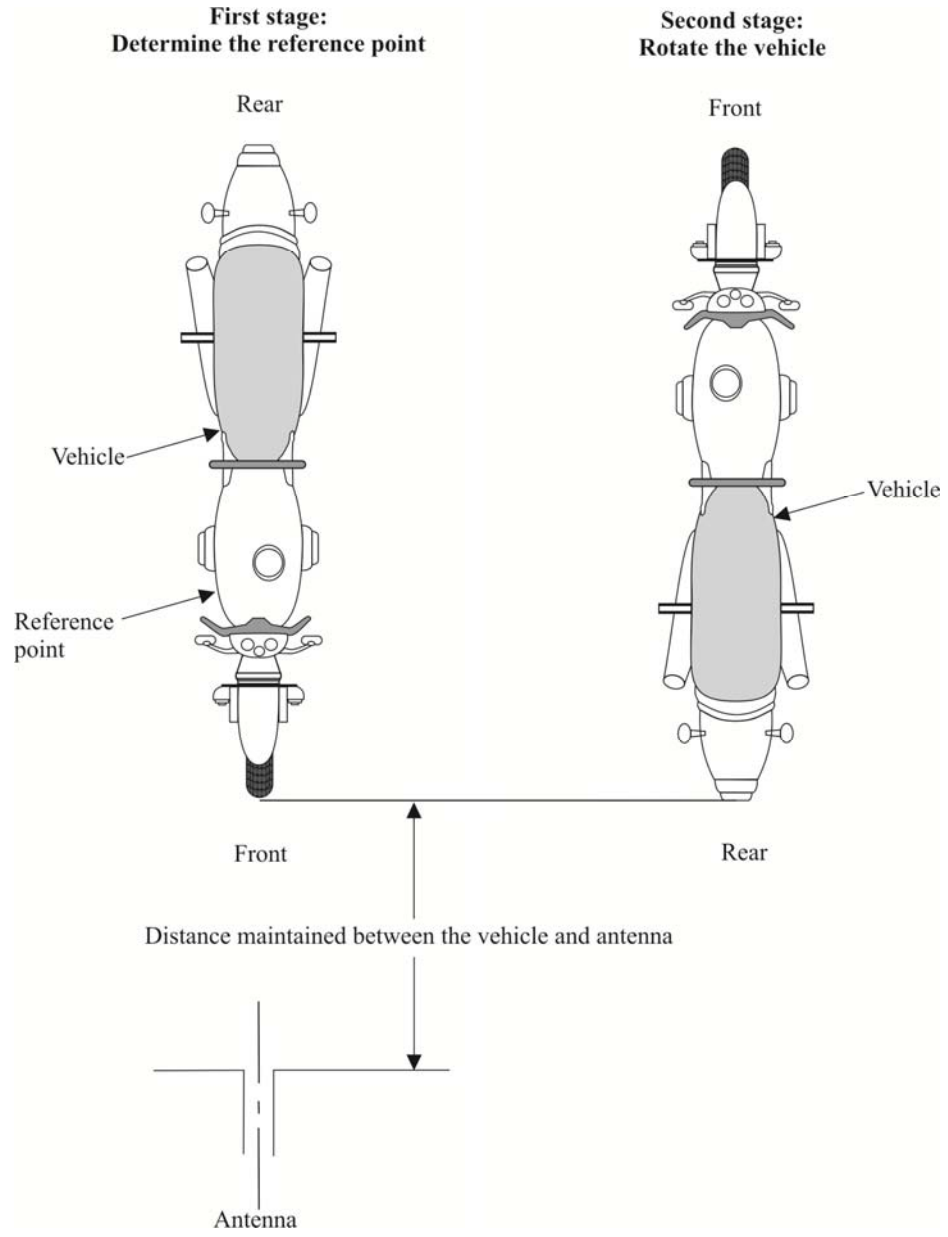
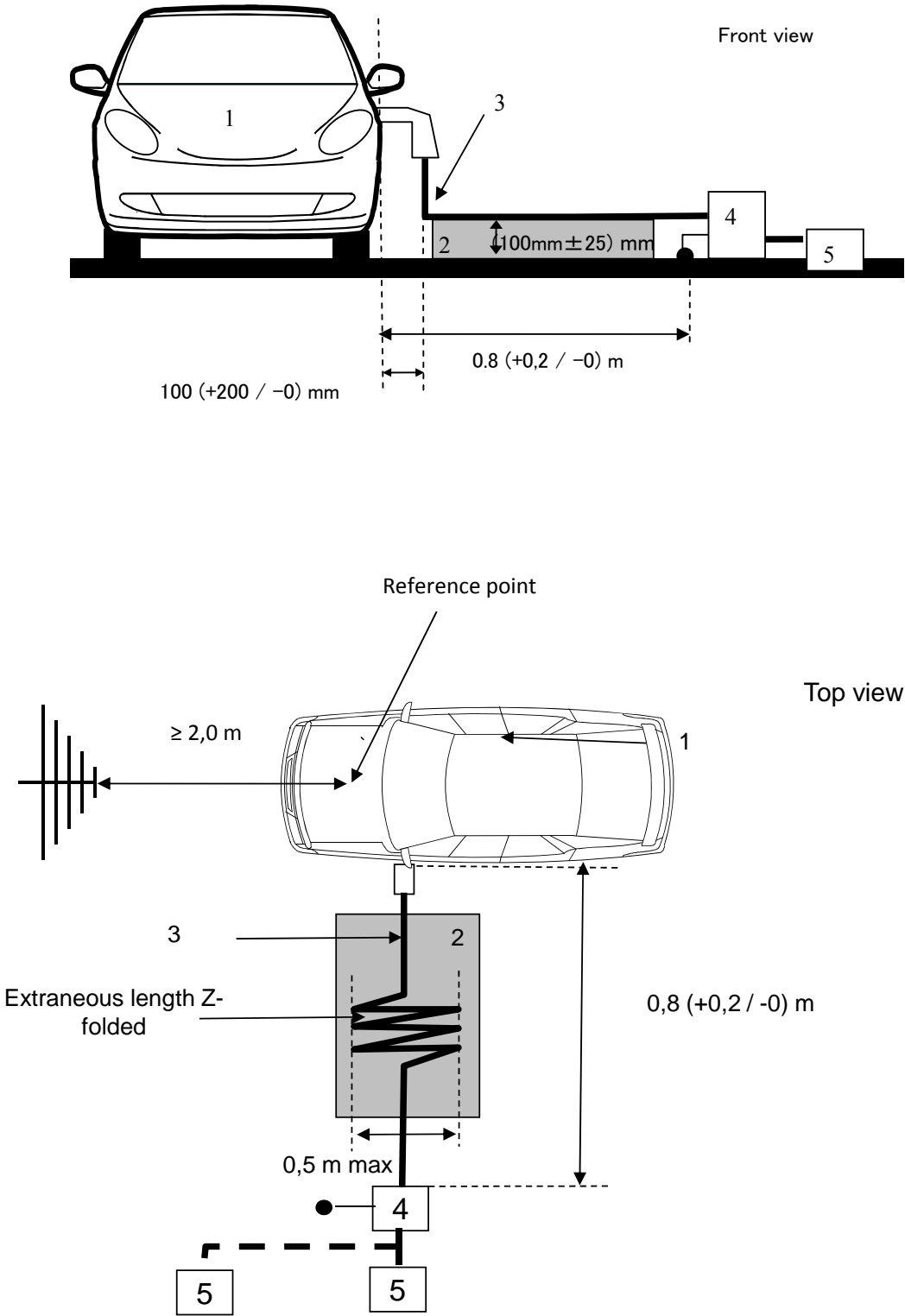

Figure 4
Vehicle in configuration "REESS in charging mode coupled to the power grid"



Key

- 1 Vehicle under test
- 2 Insulating support
- 3 Charging cable
- 4 Artificial Network(s) grounded
- 5 Power mains socket

Figures 4a and 4b – Example of test setup for vehicle with plug located on the vehicle side (AC power charging without communication)

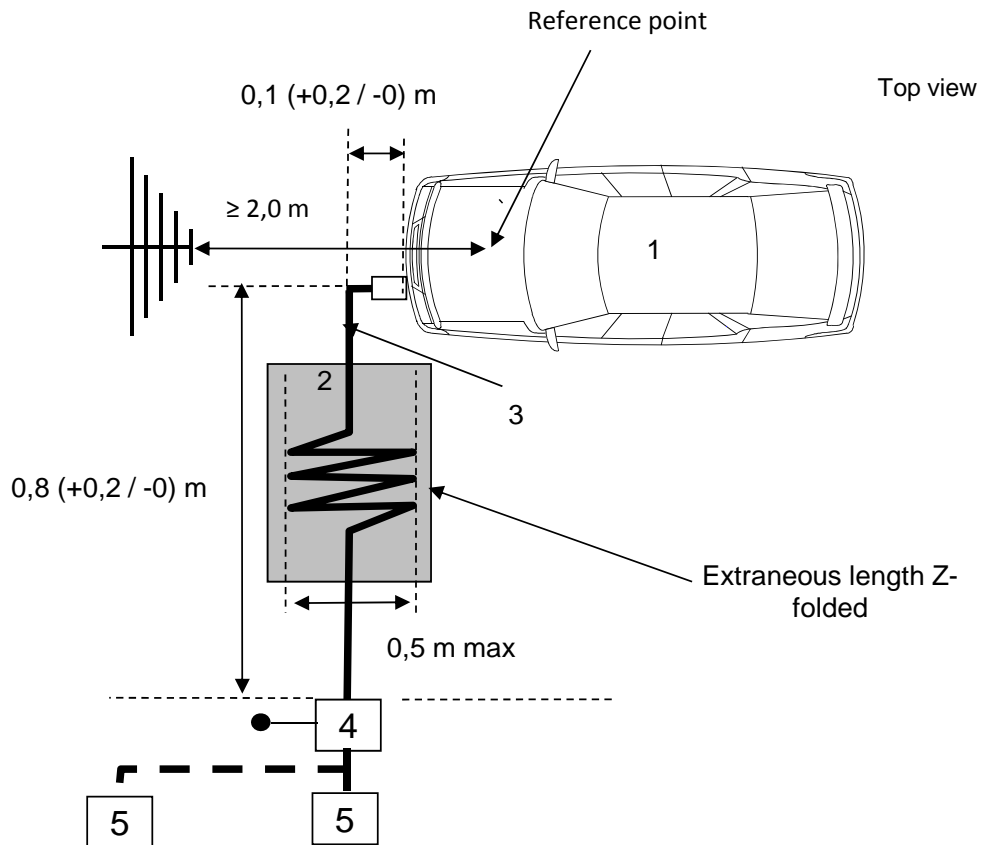
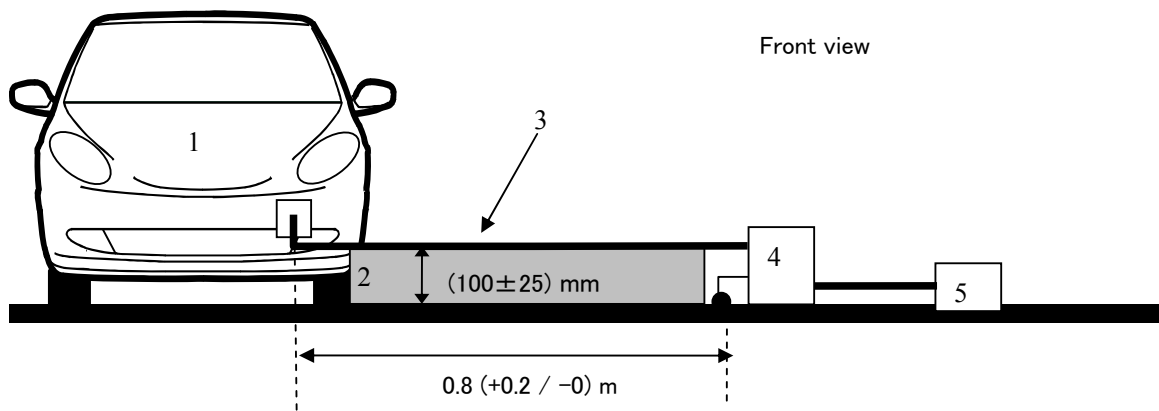

Key

- 1 Vehicle under test
- 2 Insulating support
- 3 Charging cable
- 4 Artificial Network(s) grounded
- 5 Power mains socket

Figures 4c and 4d – Example of test setup for vehicle with plug located front / rear of vehicle (AC power charging without communication)

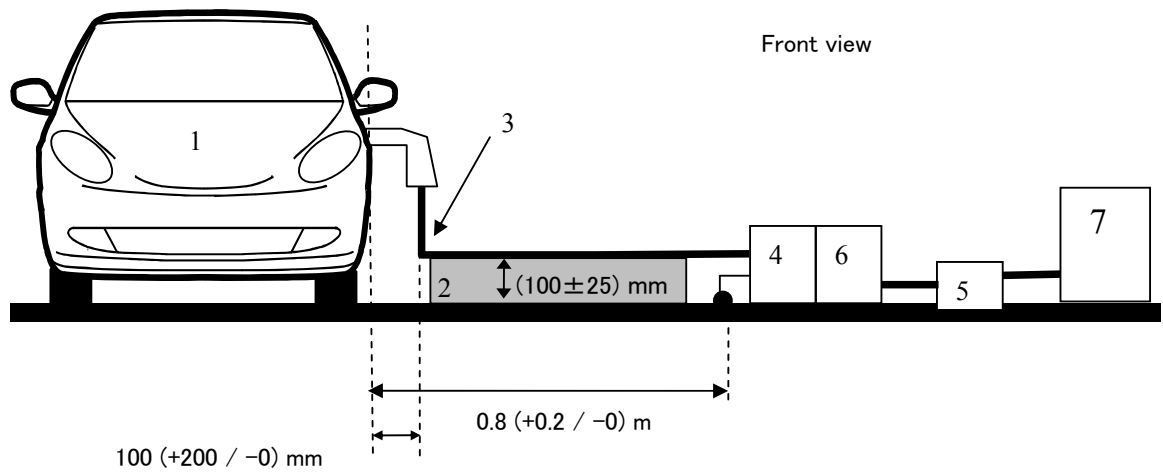

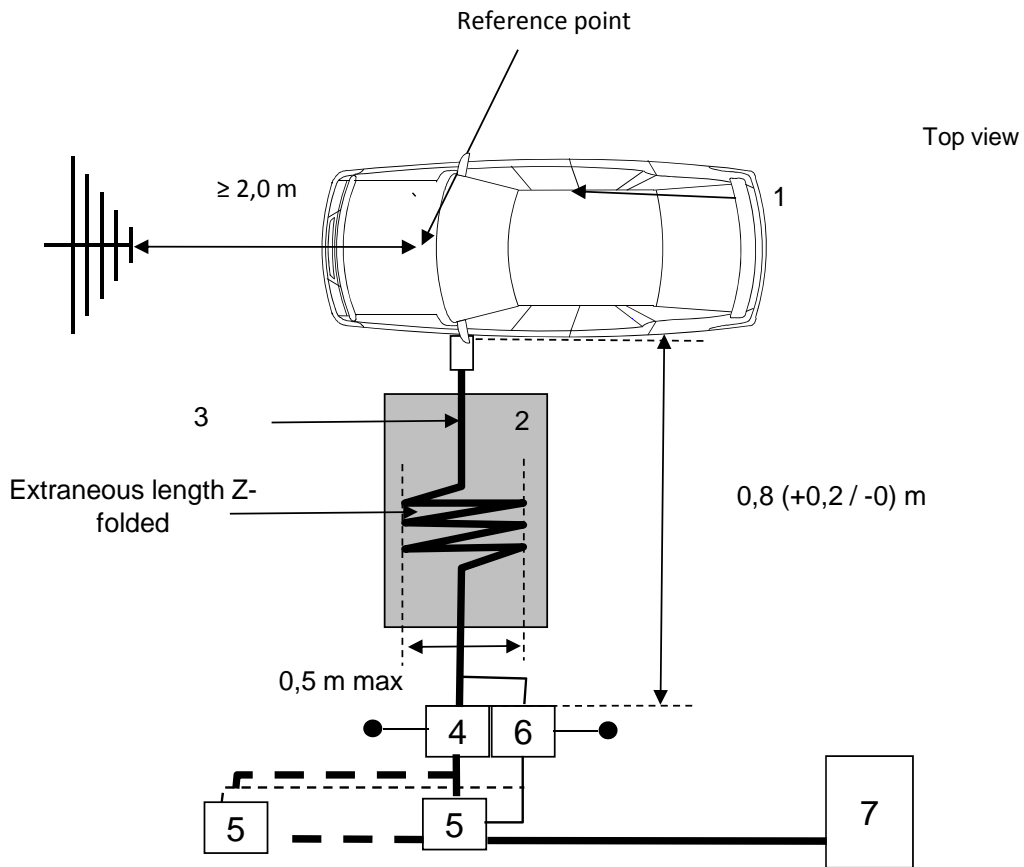

Key

- 1 Vehicle under test
- 2 Insulating support
- 3 Charging / communication cable
- 4 AC or DC Artificial Network(s) grounded
- 5 Power mains socket
- 6 Impedance Stabilisation(s) grounded
- 7 Charging Station

Figures 4e and 4f – Example of test setup for vehicle with plug located on vehicle side (AC or DC power charging with communication)

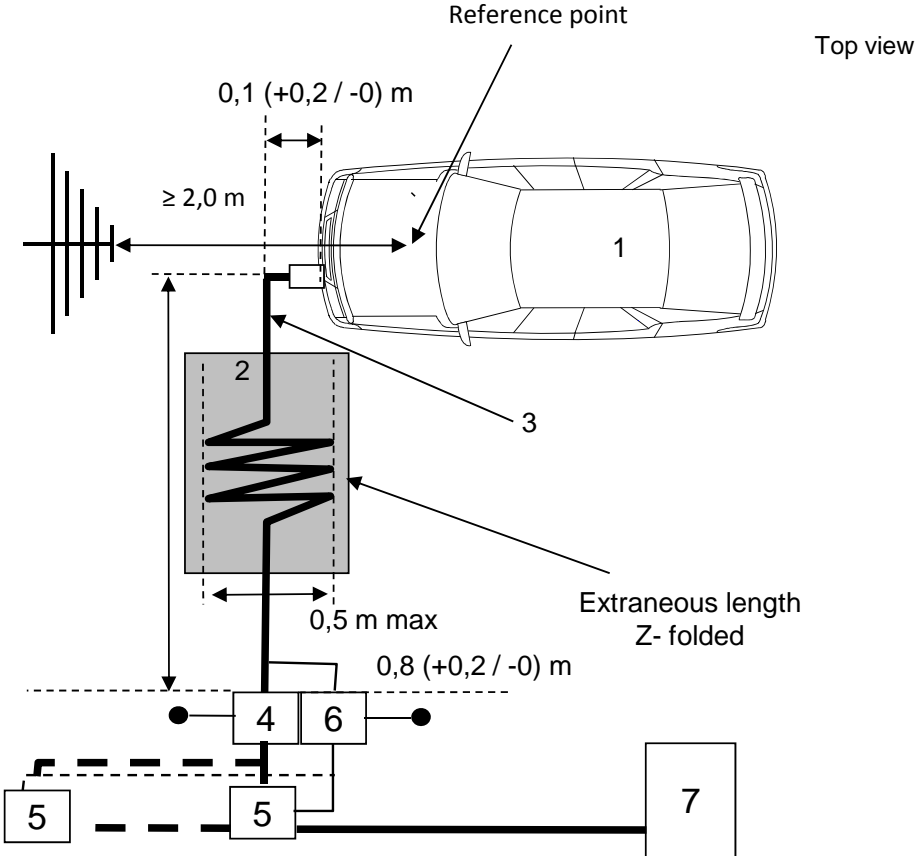
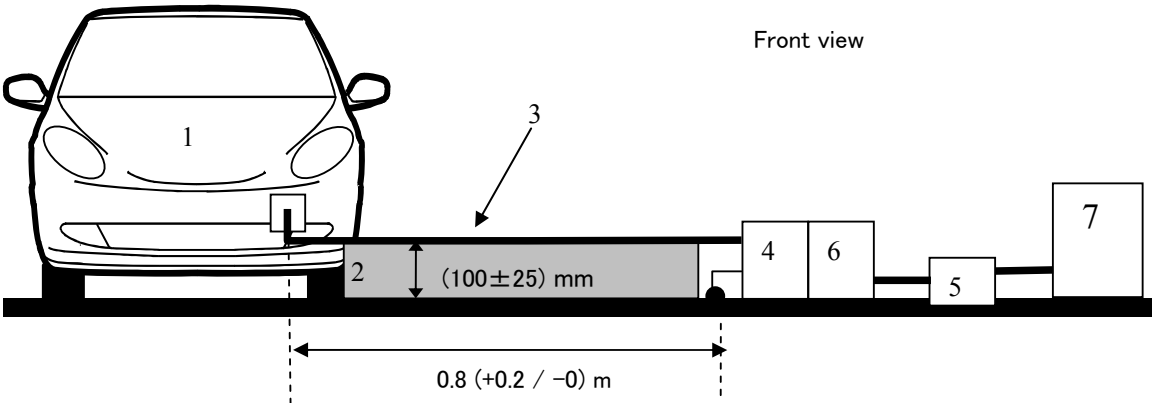

Key

- 1 Vehicle under test**
- 2 Insulating support**
- 3 Charging / communication cable**
- 4 AC or DC Artificial Network(s) grounded**
- 5 Power mains socket**
- 6 Impedance Stabilisation(s) grounded**
- 7 Charging Station**

Figure 4g and 4h – Example of test setup for vehicle with plug located front / rear of the vehicle (AC or DC power charging with communication)"

Annex 7, amend to read:

"Method of measurement of radiated broadband electromagnetic emissions from electrical/electronic sub-assemblies (ESAs)

- 1. General
 - 1.1. The test method described in this annex may be applied to ESAs, which may be subsequently fitted to vehicles, which comply with Annex 4.

This method concerns both kinds of ESA:

 - (a) other ESAs than involved in “REESS charging mode coupled to the power grid”.**
 - (b) ESAs involved in “REESS charging mode coupled to the power grid”**
 - 1.2. Test method

This test is intended to measure broadband electromagnetic emissions from ESAs (e.g. ignition systems, electric motor, **onboard battery charging unit** etc.).

If not otherwise stated in this annex the test shall be performed according *CISPR 25 (second edition 2002 and corrigendum 2004)*.
- 2. ESA state during tests
 - 2.1. The ESA under test shall be in normal operation mode, preferably in maximum load.

ESAs involved in “REESS charging mode coupled to the power grid” shall be in charging mode.

The state of charge (SOC) of the traction battery shall be kept between 20 per cent and 80 per cent of the maximum SOC during the whole frequency range measurement (this may lead to split the measurement in different sub-bands with the need to discharge the vehicle’s traction battery before starting the next sub-bands)

If the test is not performed with a REESS the ESA should be tested at rated current. If the current consumption can be adjusted, then the current shall be set to at least 80 per cent of its nominal value.

3. Test arrangements
 - 3.1. For ESA other than involved in “REESS charging mode coupled to the power grid” the test shall be performed according to CISPR 25, (~~second edition 2002 and corrigendum 2004~~) clause 6.4. - ALSE method.
 - 3.2. For ESAs in configuration “REESS charging mode coupled to the power grid” the test arrangement shall be according to Annex 7 – Appendix 1, Figure 2
 - 3.2.1. The shielding configuration shall be according to the vehicle series configuration. Generally all shielded HV parts shall be properly connected with low impedance to ground (e. g. AN, cables, connectors etc.). ESAs and loads shall be connected to ground. The external HV power supply shall be connected via feed-through-filtering.
 - 3.2.2. Unless otherwise specified, the length of the LV harness and the HV harness shall be 1,700 mm + 300/ -0 mm. The distance between the LV harness and the HV harness shall be 100 mm +100/ -0mm.
 - 3.2.3. All of the harnesses shall be placed on a non-conductive, low relative permittivity material ($\epsilon_r \leq 1.4$), at (50 ±5) mm above the ground plane.
 - 3.2.4. Shielded supply lines for HV+ and HV- line and three phase lines may be coaxial cables or in a common shield depending on the used plug system. The original HV-harness from the vehicle may be used optionally.
 - 3.2.5. Unless otherwise specified, the ESA case shall be connected to the ground plane either directly or via defined impedance.
 - 3.2.6. For onboard chargers, the AC/DC power lines shall be placed the furthest from the antenna (behind LV and HV harness). The distance between the AC/DC power lines and the closest harness (LV or HV) shall be 100 mm +100/ -0mm.
 - ~~3.2.~~ 3.3. Alternative measuring location

As an alternative to an absorber lined shielded enclosure (ALSE) an open area test site (OATS), which complies with the requirements of CISPR 16-1-4 (~~third edition 2010~~) may be used (see appendix of this annex).
 - ~~3.3.~~ 3.4. Ambient

To ensure that there is no extraneous noise or signal of a magnitude sufficient to affect materially the measurement, measurements shall be taken before or after the main test. In this measurement, the extraneous noise or signal shall be at least 6 dB below the limits of interference given in paragraph 6.5.2.1. of this Regulation, except for intentional narrowband ambient transmissions.
4. Test requirements
 - 4.1. The limits apply throughout the frequency range 30 to 1,000 MHz for measurements performed in a semi anechoic chamber or an outdoor test site.
 - 4.2. Measurements can be performed with either quasi-peak or peak detectors. The limits given in paragraphs 6.2. and 6.5. of this Regulation are for quasi-

peak detectors. If peak detectors are used a correction factor of 20 dB as defined in CISPR 12 (~~fifth edition 2001 and Amd1:2005~~) shall be applied.

- 4.3. **The measurements shall be performed with a spectrum analyser or a scanning receiver. The parameters to be used are defined in Table 1 and Table 2.**

Table 1
Spectrum analyser parameters

<i>Frequency range MHz</i>	<i>Peak detector</i>		<i>Quasi-peak detector</i>		<i>Average detector</i>	
	<i>RBW at -3 dB</i>	<i>Scan time</i>	<i>RBW at -6 dB</i>	<i>Scan time</i>	<i>RBW at -3 dB</i>	<i>Scan time</i>
30 to 1 000	100/120 kHz	100 ms/MHz	120 kHz	20 s/MHz	100/120 kHz	100 ms/MHz

Note: If a spectrum is used for peak measurements, the video bandwidth shall be at least three times the resolution bandwidth (RBW).

Table 2
Scanning receiver parameters

<i>Frequency range MHz</i>	<i>Peak detector</i>			<i>Quasi-peak detector</i>			<i>Average detector</i>		
	<i>BW at -6 dB</i>	<i>Step size^{a)}</i>	<i>Dwell time</i>	<i>BW at -6 dB</i>	<i>Step size^{a)}</i>	<i>Dwell time</i>	<i>BW at -6 dB</i>	<i>Step size^{a)}</i>	<i>Dwell time</i>
30 to 1 000	120 kHz	50 kHz	5 ms	120 kHz	50 kHz	1 s	120 kHz	50 kHz	5 ms

a) For purely broadband disturbances, the maximum frequency step size may be increased up to a value not greater than the bandwidth value.

Note: For emissions generated by brush commutator motors without an electronic control unit, the maximum step size may be increased up to 5 times the bandwidth.

4.3.4.4. Measurements

Unless otherwise specified the configuration with the LV harness closer to the antenna shall be tested.

The phase centre of the antenna shall be in line with the centre of the longitudinal part of the wiring harnesses for frequencies up to 1000 MHz.

The phase centre of the antenna for frequencies above 1000 MHz shall be in line with the ESA.

The Technical Service shall perform the test at the intervals specified in the CISPR 12 (~~fifth edition 2001 and Amd1:2005~~) standard throughout the frequency range 30 to 1,000 MHz.

Alternatively, if the manufacturer provides measurement to data for the whole frequency band from a test laboratory accredited to the applicable parts of ISO 17025 (~~second edition 2005 and Corrigendum:2006~~) and recognized

<i>Key</i>	
<i>1 ESA (grounded locally if required in test plan)</i>	<i>11 Bulkhead connector</i>
<i>2 LV Test harness</i>	<i>12 Measuring instrument</i>
<i>3 LV Load simulator (placement and ground connection according to CISPR 25 paragraph 6.4.2.5)</i>	<i>13 RF absorber material</i>
<i>4 Power supply (location optional)</i>	<i>14 Stimulation and monitoring system</i>
<i>5 LV Artificial network (AN)</i>	<i>15 HV harness</i>
<i>6 Ground plane (bonded to shielded enclosure)</i>	<i>16 HV load simulator</i>
<i>7 Low relative permittivity support ($\epsilon_r \leq 1,4$)</i>	<i>17 HV AN</i>
<i>8 Biconical antenna</i>	<i>18 HV power supply</i>
<i>10 High-quality coaxial cable e.g. double-shielded (50Ω)</i>	<i>19 HV feed-through</i>
	<i>25 AC/DC charger harness</i>
	<i>26 AC/DC load simulator (e.g. PLC)</i>
	<i>27 50μH LISN (AC) or HVAN (DC)</i>
	<i>28 AC/DC power supply</i>
	<i>29 AC/DC feed-through</i>

Annex 8, amend to read:

"Method of measurement of radiated narrowband electromagnetic emissions from electrical/electronic sub-assemblies

1. General
 - 1.1. The test method described in this annex may be applied to ESAs, which may be subsequently fitted to vehicles, which comply, with Annex 45.
This method concerns only ESA other than those involved in "REESS charging mode coupled to the power grid".
 - 1.2. Test method
This test is intended to measure the narrowband electromagnetic emissions such as might emanate from a microprocessor-based system.
If not otherwise stated in this annex the test shall be performed according to CISPR 25 (~~second edition 2002 and corrigendum 2004~~).
2. ESA state during tests
The ESA under test shall be in normal operation mode, preferably in maximum load.
3. Test arrangements
 - 3.1. The test shall be performed according CISPR 25 (~~second edition 2002 and corrigendum 2004~~), clause 6.4. - ALSE method.
 - 3.2. Alternative measuring location
As an alternative to an absorber lined shielded enclosure (ALSE) an open area test site (OATS) which complies with the requirements of CISPR 16-1-4 (~~third edition 2010~~) may be used (see Appendix 1 to Annex 7, **Figure 1**).
 - 3.3. Ambient

To ensure that there is no extraneous noise or signal of a magnitude sufficient to affect materially the measurement, measurements shall be taken before or after the main test. In this measurement, the extraneous noise or signal shall be at least 6 dB below the limits of interference given in paragraph 6.6.2.1. of this Regulation, except for intentional narrowband ambient transmissions.

4. Test requirements
 - 4.1. The limits apply throughout the frequency range 30 to 1,000 MHz for measurements performed in semi anechoic chambers or outdoor test sites.
 - 4.2. Measurements shall be performed with an average detector.
 - 4.3. **The measurements shall be performed with a spectrum analyser or a scanning receiver. The parameters to be used are defined in Table 1 and 2.**

Table 1
Spectrum analyser parameters

Frequency range MHz	Peak detector		Quasi-peak detector		Average detector	
	RBW at -3 dB	Scan time	RBW at -6 dB	Scan time	RBW at -3 dB	Scan time
30 to 1 000	100/120 kHz	100 ms/MHz	120 kHz	20 s/MHz	100/120 kHz	100 ms/MHz

Note: If a spectrum is used for peak measurements, the video bandwidth shall be at least three times the resolution bandwidth (RBW)

Table 2
Scanning receiver parameters

Frequency range MHz	Peak detector			Quasi-peak detector			Average detector		
	BW at -6 dB	Step size ^{a)}	Dwell time	BW at -6 dB	Step size ^{a)}	Dwell time	BW at -6 dB	Step size ^{a)}	Dwell time
30 to 1 000	120 kHz	50 kHz	5 ms	120 kHz	50 kHz	1 s	120 kHz	50 kHz	5 ms

a) For purely broadband disturbances, the maximum frequency step size may be increased up to a value not greater than the bandwidth value.

Note: For emissions generated by brush commutator motors without an electronic control unit, the maximum step size may be increased up to 5 times the bandwidth.

4.3. 4.4. Measurements

The Technical Service shall perform the test at the intervals specified in the CISPR 12 (~~fifth edition 2001 and Amendment:2005~~) standard throughout the frequency range 30 to 1,000 MHz.

Alternatively, if the manufacturer provides measurement to data for the whole frequency band from a test laboratory accredited to the applicable parts of ISO 17025 (~~second edition 2005 and corrigendum 2006~~) and recognized by the Approval Authority, the Technical Service may divide the frequency

range in 14 frequency bands 30 – 34, 34 – 45, 45 – 60, 60 – 80, 80 – 100, 100 – 130, 130 – 170, 170 – 225, 225 – 300, 300– 400, 400 – 525, 525 – 700, 700 – 850, 850 – 1,000 MHz and perform tests at the 14 frequencies giving the highest emission levels within each band to confirm that the ESA meets the requirements of this annex. In the event that the limit is exceeded during the test, investigations shall be made to ensure that this is due to the ESA and not to background radiation including broadband radiation from the ESA.

4.4. 4.5. Readings

The maximum of the readings relative to the limit (horizontal/vertical polarisation) in each of the 14 frequency bands shall be taken as the characteristic reading at the frequency at which the measurements were made."

Annex 9, amend to read:

"Method(s) of testing for immunity of electrical/electronic sub-assemblies to electromagnetic radiation

1. General

1.1. The test method(s) described in this annex applies to ESAs.

1.2. Test methods

This method concerns both kinds of ESA:

(a) other ESAs than involved in "REESS charging mode coupled to the power grid".

(b) ESAs involved in "REESS charging mode coupled to the power grid".

1.2.1. ESAs may comply with the requirements of any combination of the following test methods at the manufacturer's discretion provided that ~~this~~ **these** results in the full frequency range specified in paragraph 3.1. of this annex being covered:

(a) Absorber chamber test according ISO 11452-2, ~~second edition 2004~~;

(b) TEM cell testing according ISO 11452-3, ~~3, third edition 2001~~;

(c) Bulk current injection testing according ISO 11452-4, ~~third edition 2005 and Corrigendum 1:2009~~;

(d) Stripline testing according ISO 11452-5, ~~second edition 2002~~;

(e) 800 mm stripline according paragraph 5 of this annex.

ESAs in configuration "REESS charging mode coupled to the power grid" ~~may~~ shall comply with the requirements of the combination of the Absorber chamber test according ISO 11452-2 and Bulk current injection testing according ISO 11452-4 at the manufacturer's discretion provided that these results in the full frequency range specified in paragraph 3.1. of this annex being covered.

(Frequency range and general test conditions shall be based on ISO 11452-1) ~~third edition 2005 and Amd1:2008~~.

2. State of ESA during tests

- 2.1. The test conditions shall be according *ISO 11452-1, third edition 2005 and Amd1:2008*.
- 2.2. The ESA under test shall be switched on and must be stimulated to be in normal operation condition. It shall be arranged as defined in this annex unless individual test methods dictate otherwise.
- ESAs involved in “REESS charging mode coupled to the power grid” shall be in charging mode.**
- The state of charge (SOC) of the traction battery shall be kept between 20 per cent and 80 per cent of the maximum SOC during the whole frequency range measurement (this may lead to split the measurement in different sub-bands with the need to discharge the vehicle’s traction battery before starting the next sub-bands).**
- If the test is not performed with a REESS the ESA should be tested at rated current. If the current consumption can be adjusted, then the current shall be set to at least 20 per cent of its nominal value.**
- 2.3. Any extraneous equipment required to operate the ESA under test shall not be in place during the calibration phase. No extraneous equipment shall be closer than 1 m from the reference point during calibration.
- 2.4. To ensure reproducible measurement results are obtained when tests and measurements are repeated, the test signal generating equipment and its layout shall be to the same specification as that used during each appropriate calibration phase.
- 2.5. If the ESA under test consists of more than one unit, the interconnecting cables should ideally be the wiring harnesses as intended for use in the vehicle. If these are not available, the length between the electronic control unit and the AN shall be as defined in the standard. All cables in the wiring harness should be terminated as realistically as possible and preferably with real loads and actuators.
3. General test requirements
- 3.1. Frequency range, dwell times
- Measurements shall be made in the 20 to 2,000 MHz frequency range with frequency steps according to *ISO 11452-1, third edition 2005 and Amd1:2008*.
- The test signal modulation shall be:
- (a) AM (amplitude modulation), with 1 kHz modulation and 80 per cent modulation depth in the 20 to 800 MHz frequency range;
 - (b) PM (pulse modulation), ~~± on~~ **Ton** 577 µs, period 4,600 µs in the 800 to 2,000 MHz frequency range,
- if not otherwise agreed between Technical Service and ESA manufacturer.
- Frequency step size and dwell time shall be chosen according to *ISO 11452-1 third edition 2005 and Amd1:2008*.
- 3.2. The Technical Service shall perform the test at the intervals specified in *ISO 11452-1, third edition 2005 and Amd1:2008* throughout the frequency range 20 to 2,000 MHz.

Alternatively, if the manufacturer provides measurement to data for the whole frequency band from a test laboratory accredited to the applicable parts of ISO 17025, (~~second edition 2005 and Corrigendum 2006~~) and recognized by the Approval Authority, the Technical Service may choose a reduced number of spot frequencies in the range, e.g. 27, 45, 65, 90, 120, 150, 190, 230, 280, 380, 450, 600, 750, 900, 1,300, and 1,800 MHz to confirm that the ESA meets the requirements of this annex.

- 3.3. If an ESA fails the tests defined in this annex, it must be verified as having failed under the relevant test conditions and not as a result of the generation of uncontrolled fields.
- 4. Specific test requirements
 - 4.1. Absorber chamber test
 - 4.1.1. Test method

This test method allows the testing of vehicle electrical/electronic systems by exposing an ESA to electromagnetic radiation generated by an antenna.
 - 4.1.2. Test methodology

The "substitution method" shall be used to establish the test field conditions according ISO 11452-2, ~~second edition 2004~~.

The test shall be performed with vertical polarization.
 - 4.1.2.1. **For ESAs in configuration "REESS charging mode coupled to the power grid" the test arrangement shall be according to Annex 9 - Appendix 3.**
 - 4.1.2.1.1. **The shielding configuration shall be according to the vehicle series configuration. Generally all shielded HV parts shall be properly connected with low impedance to ground (e. g. AN, cables, connectors etc.). ESAs and loads shall be connected to ground. The external HV power supply shall be connected via feed-through-filtering.**
 - 4.1.2.1.2. **Unless otherwise specified, the length of the LV harness and the HV harness shall be 1,700 mm + 300/ -0 mm. The distance between the LV harness and the HV harness shall be 100 mm +100/ -0mm.**
 - 4.1.2.1.3. **All of the harnesses shall be placed on a non-conductive, low relative permittivity material ($\epsilon_r \leq 1,4$), at 50 ±5 mm above the ground plane.**
 - 4.1.2.1.4. **Shielded supply lines for HV+ and HV- line and three phase lines may be coaxial cables or in a common shield depending on the used plug system. The original HV-harness from the vehicle may be used optionally.**
 - 4.1.2.1.5. **Unless otherwise specified, the ESA case shall be connected to the ground plane either directly or via defined impedance.**
 - 4.1.2.1.6. **For onboard chargers, the AC/DC power lines shall be placed the furthest from the antenna (behind LV and HV harness). The distance between the AC/DC power lines and the closest harness (LV or HV) shall be 100 mm +100/-0mm.**
 - 4.1.2.1.7. **Unless otherwise specified the configuration with the LV harness closer to the antenna shall be tested.**
 - 4.2. TEM cell testing (see Appendix 2 to this annex)
 - 4.2.1. Test method

- The TEM (transverse electromagnetic mode) cell generates homogeneous fields between the internal conductor (septum) and housing (ground plane).
- 4.2.2. Test methodology
- The test shall be performed according ISO 11452-3 ~~third edition 2001~~.
- Depending on the ESA to be tested the Technical Service shall chose the method of maximum field coupling to the ESA or to the wiring harness inside the TEM-cell.
- 4.3. Bulk current injection testing
- 4.3.1. Test method
- This is a method of carrying out immunity tests by inducing currents directly into a wiring harness using a current injection probe.
- 4.3.2. Test methodology
- The test shall be performed according to ISO 11452-4 ~~third edition 2005 and Corrigendum 1:2009~~ on a test bench. As an alternative the ESA may be tested while installed in the vehicle according to ISO 11451-4 ~~(first edition 1995)~~ with the following characteristics:
- (a) the injection probe shall be positioned in 150 mm distance to the ESA to be tested;
 - (b) the reference method shall be used to calculate injected currents from forward power;
 - (c) the frequency range of the method is limited by the injection probe specification.
- 4.3.2.1. For ESAs in configuration “REESS charging mode coupled to the power grid”, the test arrangement shall be according to Annex 9 – Appendix 4.**
- 4.3.2.1.1. The shielding configuration shall be according to the vehicle series configuration. Generally all shielded HV parts shall be properly connected with low impedance to ground (e. g. AN, cables, connectors, etc.). ESAs and loads shall be connected to ground. The external HV power supply shall be connected via feed-through-filtering.**
- 4.3.2.1.2. Unless otherwise specified the length of the LV harness and the HV harness shall be 1,700 mm + 300/ -0 mm. The distance between the LV harness and the HV harness shall be 100 mm +100/-0mm.**
- 4.3.2.1.3. All of the harnesses shall be placed on a non-conductive, low relative permittivity material ($\epsilon_r \leq 1.4$), at (50 ±5) mm above the ground plane.**
- 4.3.2.1.4. Shielded supply lines for HV+ and HV- line and three phase lines may be coaxial cables or in a common shield depending on the used plug system. The original HV-harness from the vehicle may be used optionally.**
- 4.3.2.1.5. Unless otherwise specified, the ESA case shall be connected to the ground plane either directly or via defined impedance.**
- 4.3.2.1.6. Unless otherwise specified the test shall be performed with the injection probe placed around each following harness:**
- low voltage harness
 - high voltage harness

- AC power lines if applicable
- DC power lines if applicable

- 4.4. Stripline testing
 - 4.4.1. Test method

This test method consists of subjecting the wiring harness connecting the components in an ESA to specified field strengths.
 - 4.4.2. Test methodology

The test shall be performed according ISO 11452-5 ~~second edition 2002~~.
- 4.5. 800 mm stripling testing
 - 4.5.1. Test method

The stripline consists of two parallel metallic plates separated by 800 mm. Equipment under test is positioned centrally between the plates and subjected to an electromagnetic field (see Appendix 1 to this annex).

This method can test complete electronic systems including sensors and actuators as well as the controller and wiring loom. It is suitable for apparatus whose largest dimension is less than one-third of the plate separation.
 - 4.5.2. Test methodology
 - 4.5.2.1. Positioning of stripline

The stripline shall be housed in a screened room (to prevent external emissions) and positioned 2 m away from walls and any metallic enclosure to prevent electromagnetic reflections. RF absorber material may be used to damp these reflections. The stripline shall be placed on non-conducting supports at least 0.4 m above the floor.
 - 4.5.2.2. Calibration of the stripline

A field-measuring probe shall be positioned within the central one-third of the longitudinal, vertical and transverse dimensions of the space between the parallel plates with the system under test absent.

The associated measuring equipment shall be sited outside the screen room. At each desired test frequency, a level of power shall be fed into the stripline to produce the required field strength at the antenna. This level of forward power, or another parameter directly related to the forward power required to define the field, shall be used for type approval tests unless changes occur in the facilities or equipment, which necessitate this procedure being repeated.
 - 4.5.2.3. Installation of the ESA under test

The main control unit shall be positioned within the central one third of the longitudinal, vertical and transverse dimensions of the space between the parallel plates. It shall be supported on a stand made from non-conducting material.
 - 4.5.2.4. Main wiring loom and sensor/actuator cables

The main wiring loom and any sensor/actuator cables shall rise vertically from the control unit to the top ground plate (this helps to maximize coupling with the electromagnetic field). Then they shall follow the underside of the plate to one of its free edges where they shall loop over and follow the top of the ground plate as far as the connections to the stripline feed. The cables

shall then be routed to the associated equipment, which shall be sited in an area outside the influence of the electromagnetic field, e.g. on the floor of the screened room 1 m longitudinally away from the stripline."

Annex 9, insert new Appendix 3

"Annex 9 – Appendix 3

Absorber chamber test

Test configuration for ESA's involved in "REESS charging mode coupled to the power grid". The test shall be performed according to ISO 11452-2.

Top view (horizontal polarization)

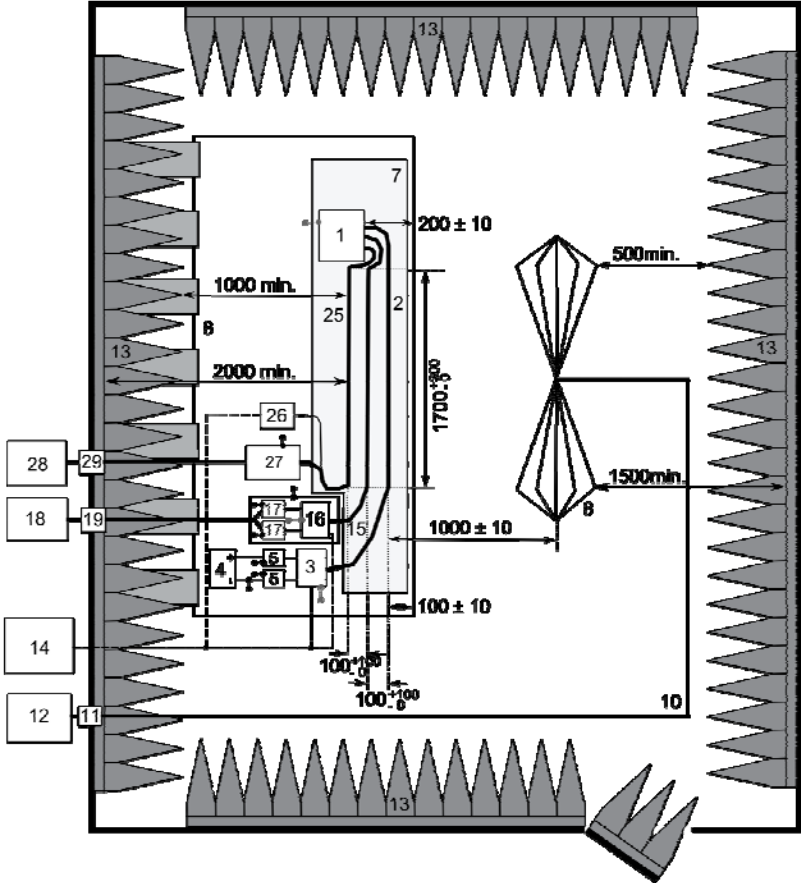

Key

<i>1 ESA (grounded locally if required in test plan)</i>	<i>12 RF signal generator and amplifier</i>
<i>2 LV Test harness</i>	<i>13 RF absorber material</i>
<i>3 LV Load simulator (placement and ground connection according to CISPR 25 paragraph 6.4.2.5)</i>	<i>14 Stimulation and monitoring system</i>
<i>4 Power supply (location optional)</i>	<i>15 HV harness</i>
<i>5 LV Artificial network (AN)</i>	<i>16 HV load simulator</i>
<i>6 Ground plane (bonded to shielded enclosure)</i>	<i>17 HV AN</i>
<i>7 Low relative permittivity support ($\epsilon_r \leq 1,4$)</i>	<i>18 HV power supply</i>
<i>8 Biconical antenna</i>	<i>19 HV feed-through</i>
<i>10 High-quality coaxial cable e.g. double-shielded (50 Ω)</i>	<i>25 AC/DC charger harness</i>
<i>11 Bulkhead connector"</i>	<i>26 AC/DC load simulator (e.g. PLC)</i>
	<i>27 50μH LISN (AC) or HVAN (DC)</i>
	<i>28 AC/DC power supply</i>
	<i>29 AC/DC feed-through</i>

Annex 9, insert new Appendix 4

"Annex 9 – Appendix 4

BCI test

Test configuration for ESAs involved in "REESS charging mode coupled to the power grid". The test shall be performed according to ISO 11452-4.

Top view (horizontal polarization)

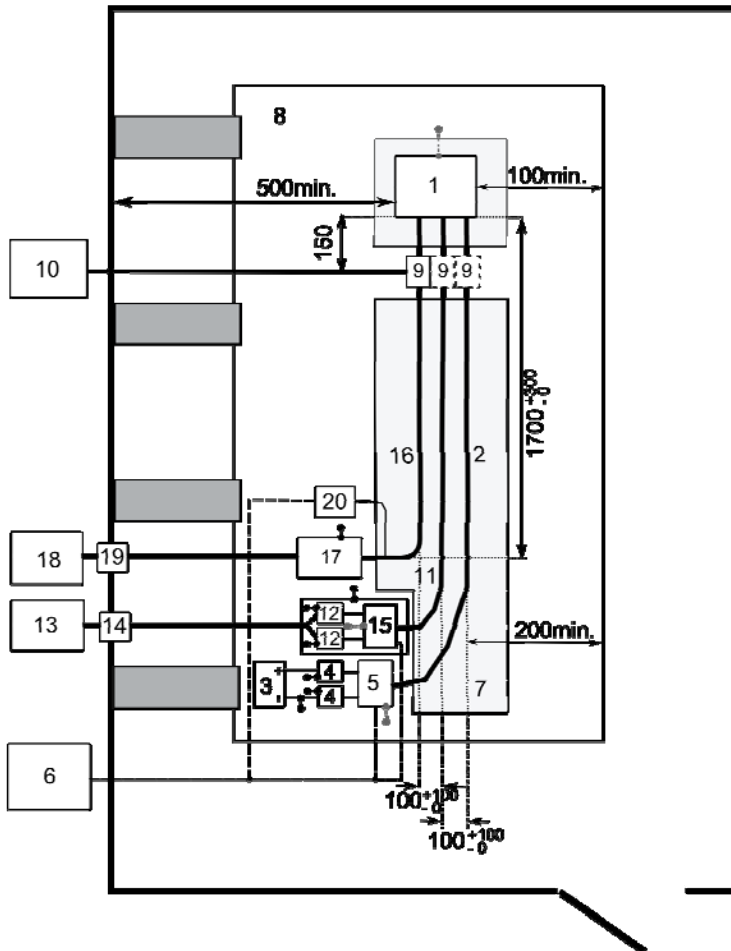

Key

- | | |
|---|---------------------------------------|
| 1 ESA (grounded locally if required in test plan) | 11 HV DC harness |
| 2 LV Test harness | 12 HV AN |
| 3 LV supply | 13 HV DC load |
| 4 LV LISN | 14 HV DC feed-through |
| 5 LV load simulator | 15 HV DC load simulator |
| 6 Stimulation and monitoring system | 16 HV AC/DC charger harness |
| 7 Low relative permittivity support | 17 50µH LISN (AC) or HV AN (DC) |
| 8 Ground plane | 18 HV AC/DC power supply |
| 9 Injection probe | 19 HV AC/DC feed-through |
| 10 RF signal amplifier and generator | 20 HV AC/DC load simulator (e.g. PLC) |

Annex 10, amend to read:

"Method(s) of testing for immunity to and emission of transients of electrical/electronic sub-assemblies"

1. General

This test method shall ensure the immunity of ESAs to conducted transients on the vehicle power supply and limit conducted transients from ESAs to the vehicle power supply.
2. Immunity against transient disturbances conducted along 12/24 V supply lines

Apply the test pulses 1, 2a, 2b, 3a, 3b and 4 according to the International Standard ISO 7637-2 (~~second edition 2004 and Amd1:2008~~) to the supply lines as well as to other connections of ESAs which may be operationally connected to supply lines.
3. Emission of transient conducted disturbances generated by ESAs on 12/24 V supply lines

Measurement according to the International Standard ISO 7637-2 (~~second edition 2004 and Amd1:2008~~) on supply lines as well as to other connections of ESAs which may be operationally connected to supply lines."

Annex 11, amend to read:

"Method(s) of testing for emission of harmonics generated on AC power lines from vehicle"

1. General
 - 1.1. The test method described in this annex shall be applied to vehicles in configuration "REESS charging mode coupled to the power grid"
 - 1.2. Test method

This test is intended to measure the level of harmonics generated by vehicle in configuration "REESS charging mode coupled to the power grid" through its AC power lines in order to ensure it is compatible with residential, commercial and light industrial environments.

If not otherwise stated in this annex the test shall be performed according to:

 - (a) IEC 61000-3-2 (~~edition 3.2 — 2005 + Amd1:2008 + Amd2:2009~~) for input current in charging mode ≤ 16 A per phase for class A equipment,
 - (b) IEC 61000-3-12 (~~edition 1.0 — 2004~~) for input current in charging mode > 16 A and ≤ 75 A per phase.
2. Vehicle state during tests
 - 2.1. The vehicle shall be in configuration "REESS charging mode coupled to the power grid". ~~at rated power until the AC current reached at least 80 per cent of its initial value.~~

The state of charge (SOC) of the traction battery shall be kept between 20 per cent and 80 per cent of the maximum SOC during the whole frequency range measurement (this may lead to split the measurement in different sub-bands with the need to discharge the vehicle's traction battery before starting the next sub-bands). If the current consumption

can be adjusted, then the current shall be set to at least per cent of its nominal value.

The vehicle shall be immobilized, engine OFF.

And all other equipment which can be switched on permanently by the driver or passenger should be OFF.

3. Test arrangements
 - 3.1. The observation time to be used for the measurements shall be as for quasi-stationary equipment as defined in IEC 61000-3-2 (~~edition 3.2 — 2005 + Amd1:2008 + Amd2:2009~~), Table 3-4
 - 3.2. The test set-up for single phase vehicle in configuration “**REESS** charging mode coupled to the power grid” is shown in Figure 1 of Appendix 1 to this Annex.
 - 3.3. The test set-up for three-phase vehicle in configuration “**REESS** charging mode coupled to the power grid” is shown in Figure 2 of Appendix 1 to this Annex.
4. Test requirements
 - 4.1. The measurements of even and odd current harmonics shall be performed up to the 40th harmonic.
 - 4.2. The limits for single phase or three-phase “**REESS** charging mode coupled to the power grid” with input current ≤ 16 A per phase are given in paragraph 7.3.2.1, Table 3.
 - 4.3. The limits for single phase “**REESS** charging mode coupled to the power grid” with input current > 16 A and ≤ 75 A per phase are given in paragraph 7.3.2.2, Table 4.
 - 4.4. The limits for three-phase “**REESS** charging mode coupled to the power grid” with input current > 16 A and ≤ 75 A per phase are given in paragraph 7.3.2.2, Table 5.
 - 4.5. For three-phase “**REESS** charging mode coupled to the power grid” with input current > 16 A and ≤ 75 A per phase, when at least one of the three conditions a), b), c) described in IEC 61000-3-12, (~~edition 1.0 — 2004~~) clause 5.2, is fulfilled then the limits given in paragraph 7.3.2.2, Table 6 can be applied.”

Annex 11, Appendix 1, amend to read:

"Annex 11 – Appendix 1

Figure 1

Vehicle in configuration "REESS charging mode coupled to the power grid" – Single phase charger test set-up

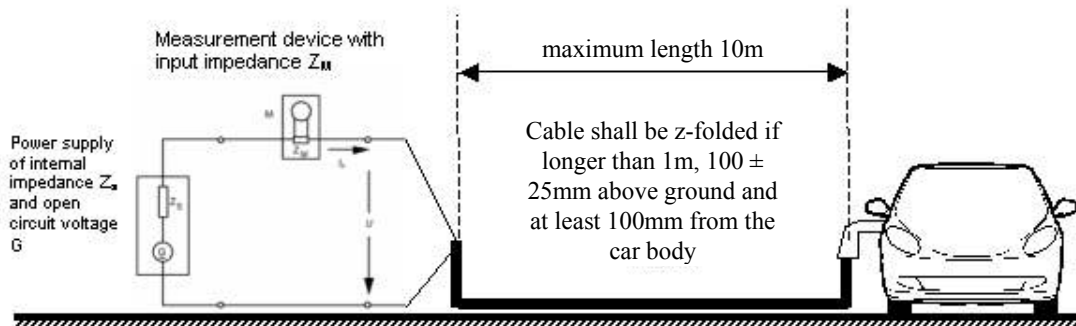
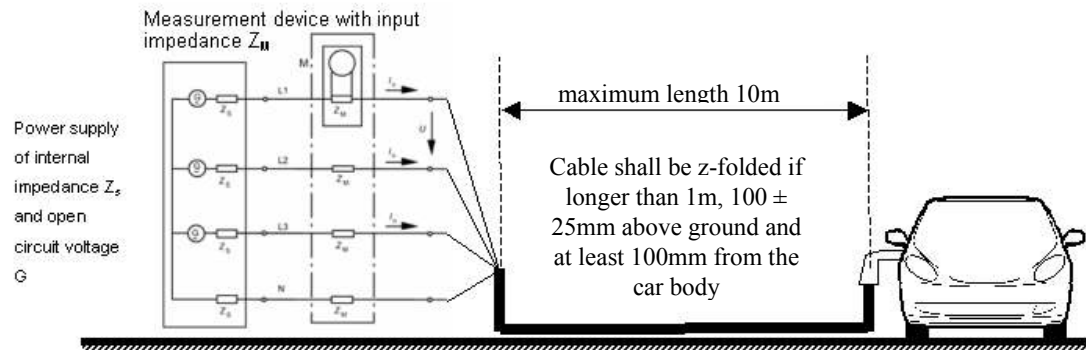

Figure 2

Vehicle in configuration "REESS charging mode coupled to the power grid" – Three-phase charger test set-up



Annex 12, amend to read:

"Method(s) of testing for emission of voltage changes, voltage fluctuations and flicker on AC power lines from vehicle

1. General
 - 1.1. The test method described in this annex shall be applied to vehicles in configuration "REESS charging mode coupled to the power grid"
 - 1.2. Test method

This test is intended to measure the level of voltage changes, voltage fluctuations and flicker generated by vehicle in configuration “REESS charging mode coupled to the power grid” through its AC power lines in order to ensure it is compatible with residential, commercial and light industrial environments.

If not otherwise stated in this annex the test shall be performed according to:

- (a) IEC 61000-3-3 (~~edition 2.0 — 2008~~) for rated current in “REESS charging mode” ≤ 16 A per phase and not subjected to conditional connection;
- (b) IEC 61000-3-11 (~~edition 1.0 — 2000~~) for rated current in “REESS charging mode” > 16 A and ≤ 75 A per phase and subjected to conditional connection.

2. Vehicle state during tests

- 2.1. The vehicle shall be in configuration “REESS charging mode coupled to the power grid” ~~at rated power until the AC current reached at least 80 per cent of its initial value..~~

The state of charge (SOC) of the traction battery shall be kept between 20 per cent and 80 per cent of the maximum SOC during the whole frequency range measurement (this may lead to split the measurement in different sub-bands with the need to discharge the vehicle’s traction battery before starting the next sub-bands). If the current consumption can be adjusted, then the current shall be set to at least 80 per cent of its nominal value.

The vehicle shall be immobilized, engine OFF.

And all other equipment which can be switched on permanently by the driver or passenger should be OFF.

3. Test arrangements

- 3.1. The tests for vehicle in configuration “REESS charging mode coupled to the power grid” with rated current ≤ 16 A per phase and not subjected to conditional connection shall be performed according IEC 61000-3-3, (~~edition 2.0 — 2008~~) paragraph 4.
- 3.2. The tests for vehicle in configuration “REESS charging mode coupled to the power grid” with rated current > 16 A and ≤ 75 A per phase and subjected to conditional connection shall be performed according IEC 61000-3-11, (~~edition 1.0 — 2000~~)-paragraph 6.
- 3.3. The test set-up for vehicle in configuration “REESS charging mode coupled to the power grid” is shown in Figure 1a and 1b of Appendix 1 to this Annex.

4. Test requirements

- 4.1. The parameters to be determined in the time-domain are “short duration flicker value”, “long duration flicker value” and “voltage relative variation”.
- 4.2. The limits for vehicle in configuration “REESS charging mode coupled to the power grid” with input current ≤ 16 A per phase and not subjected to conditional connection are given in paragraph 7.4.2.1 ~~Table 7.~~

- 4.3. The limits for vehicle in configuration “**REESS** charging mode coupled to the power grid” with input current > 16 A and ≤ 75 A per phase and subjected to conditional connection are given in paragraph 7.4.2.2 ~~Table 8.~~”

Annex 12, Appendix 1, amend to read:

"Annex 12 – Appendix 1

Figure 1a

Vehicle in configuration "REESS charging mode coupled to the power grid" – Single phase test set-up

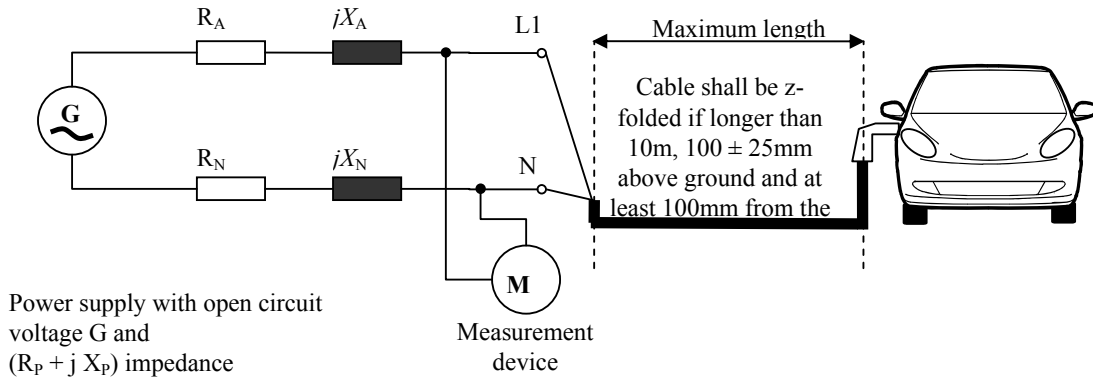
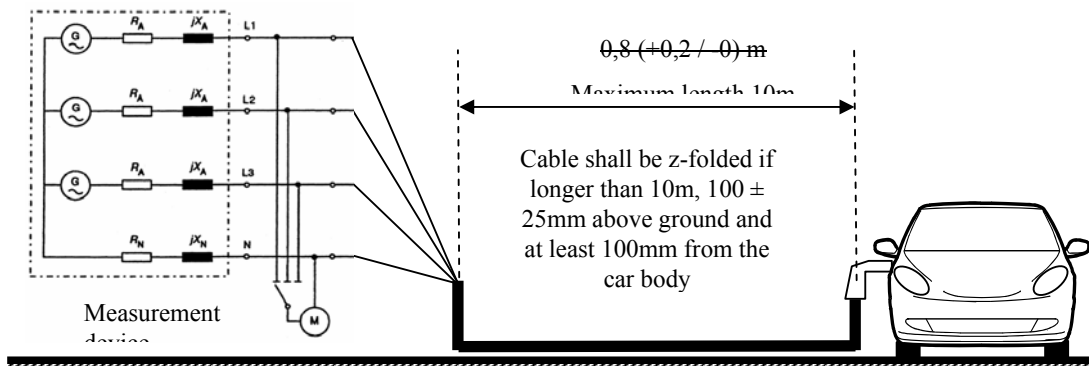

Figure 1b

Vehicle in configuration "REESS charging mode coupled to the power grid" – Three phase test set-up

Power supply with open circuit voltage G and $(R_p + j X_p)$ impedance



Annex 13, amend to read:

"Method(s) of testing for emission of radiofrequency conducted disturbances on AC or DC power lines from vehicles

1. General
 - 1.1. The test method described in this annex shall be applied to vehicles in configuration "REESS charging mode coupled to the power grid".
 - 1.2. Test method

This test is intended to measure the level of radio frequency conducted disturbances generated by vehicle in configuration "REESS charging mode coupled to the power grid" through its AC or DC power lines in order to ensure it is compatible with residential, commercial and light industrial environments.

If not otherwise stated in this annex the test shall be performed according to CISPR 16-2-1 (~~edition 2.0—2008~~).
2. Vehicle state during tests
 - 2.1. The vehicle shall be in configuration "REESS charging mode coupled to the power grid" ~~at rated power until the AC or DC current reached at least 80 per cent of its initial value.~~

The state of charge (SOC) of the traction battery shall be kept between 20 per cent and 80 per cent of the maximum SOC during the whole frequency range measurement (this may lead to split the measurement in different sub-bands with the need to discharge the vehicle's traction battery before starting the next sub-bands). If the current consumption can be adjusted, then the current shall be set to at least 80 per cent of its nominal value.

The vehicle shall be immobilized, engine OFF.

And all other equipment which can be switched on permanently by the driver or passenger should be OFF.
3. Test arrangements
 - 3.1. The test shall be performed according to CISPR 16-2-1 (~~edition 2.0—2008~~) clause 7.4.1. as floor-standing equipments.
 - 3.2. The artificial mains network to be used for the measurement on vehicle is defined in CISPR 16-1-2 (~~edition 1.2: 2006~~), Clause 4.3

Artificial networks

The AN(s) shall be mounted directly on the ground plane. The cases of the AN(s) shall be bonded to the ground plane.

The measuring port of each AN shall be terminated with a 50 Ω load.

The AN shall be placed as defined in Figures 1a to 1d.
 - 3.3. The test set-up for the connection of the vehicle in configuration "REESS charging mode coupled to the power grid" is shown in figure 1 of Appendix 1 to this annex.

- 3.4. ~~The measurements shall be performed with a spectrum analyser or a scanning receiver. The parameters to be used are respectively defined in CISPR 25 Clause 4.4.1 (table 1) and 4.4.2 (table 2).~~

The measurements shall be performed with a spectrum analyser or a scanning receiver. The parameters to be used are defined in Table 1 and Table 2.

Table 1
Spectrum analyser parameters

Frequency range MHz	Peak detector		Quasi-peak detector		Average detector	
	RBW at -3 dB	Scan time	RBW at -6 dB	Scan time	RBW at -3 dB	Scan time
0.15 to 30	9/10 kHz	10 s/MHz	9 kHz	200 s/MHz	9/10 kHz	10 s/MHz

Note: If a spectrum is used for peak measurements, the video bandwidth shall be at least three times the resolution bandwidth (RBW)

Table 2
Scanning receiver parameters

Frequency range MHz	Peak detector			Quasi-peak detector			Average detector		
	BW at -6 dB	Step size ^a	Dwell time	BW at -6 dB	Step size ^a	Dwell time	BW at -6 dB	Step size ^a	Dwell time
0.15 to 30	9 kHz	5 kHz	50 ms	9 kHz	5 kHz	1 s	9 kHz	5 kHz	50 ms

a) For purely broadband disturbances, the maximum frequency step size may be increased up to a value not greater than the bandwidth value.

4. Test Requirements

- 4.1. The limits apply throughout the frequency range 0,15 to 30 MHz for measurements performed in a semi anechoic chamber or an outdoor test site.
- 4.2. Measurements shall be performed with average and either quasi-peak or peak detectors. The limits are given in paragraph 7.5.

Table 97 for AC lines and Table 408 for DC lines. If peak detectors are used a correction factor of 20 dB as defined in CISPR 12 (fifth edition, 2001 and ~~Am1:2005~~) shall be applied."

Annex 13, Appendix 1, amend to read:

"Annex 13 – Appendix 1

Figure 1

Vehicle in configuration "REESS charging mode coupled to the power grid"

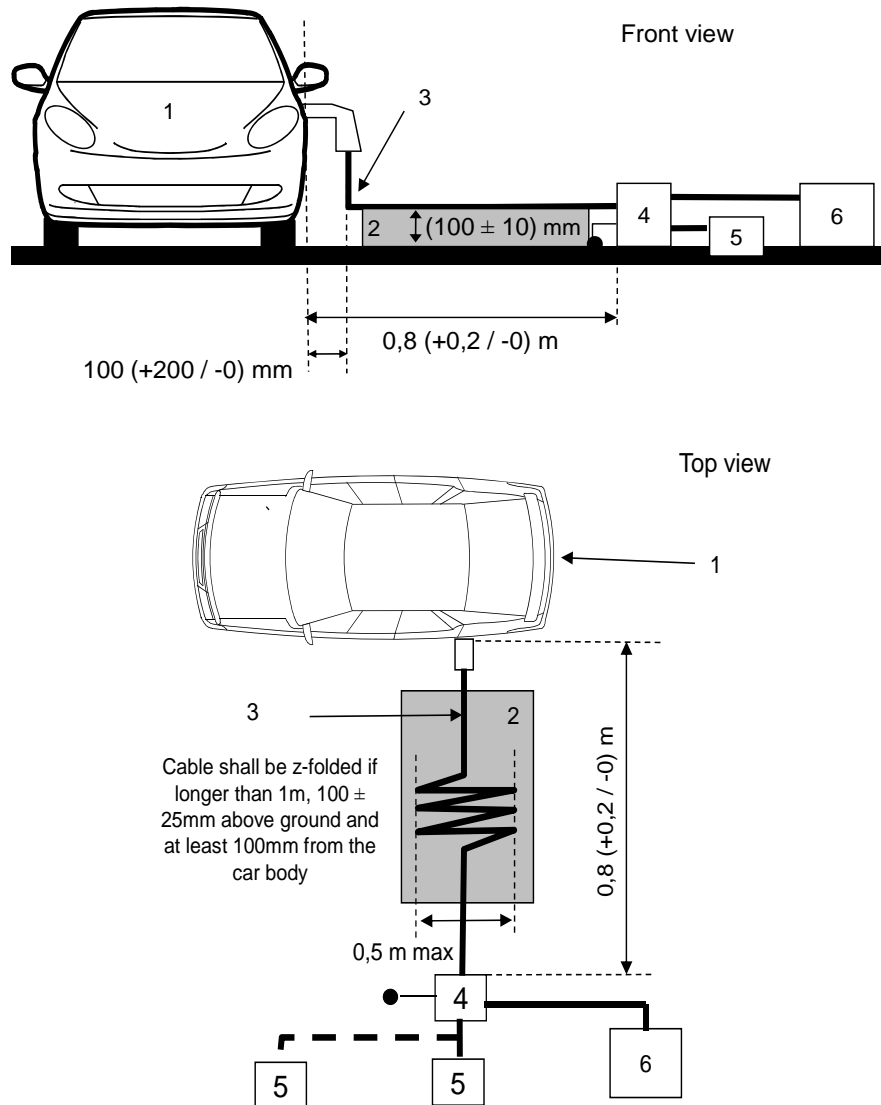

Key

- 1** Vehicle under test
- 2** Insulating support
- 3** Charging cable
- 4** Artificial Network(s) grounded (for AC or DC power lines)
- 5** Power mains socket
- 6** Measuring receiver

Figure 1a & 1b – Example of test setup for vehicle with plug located on vehicle side (AC powered without communication)

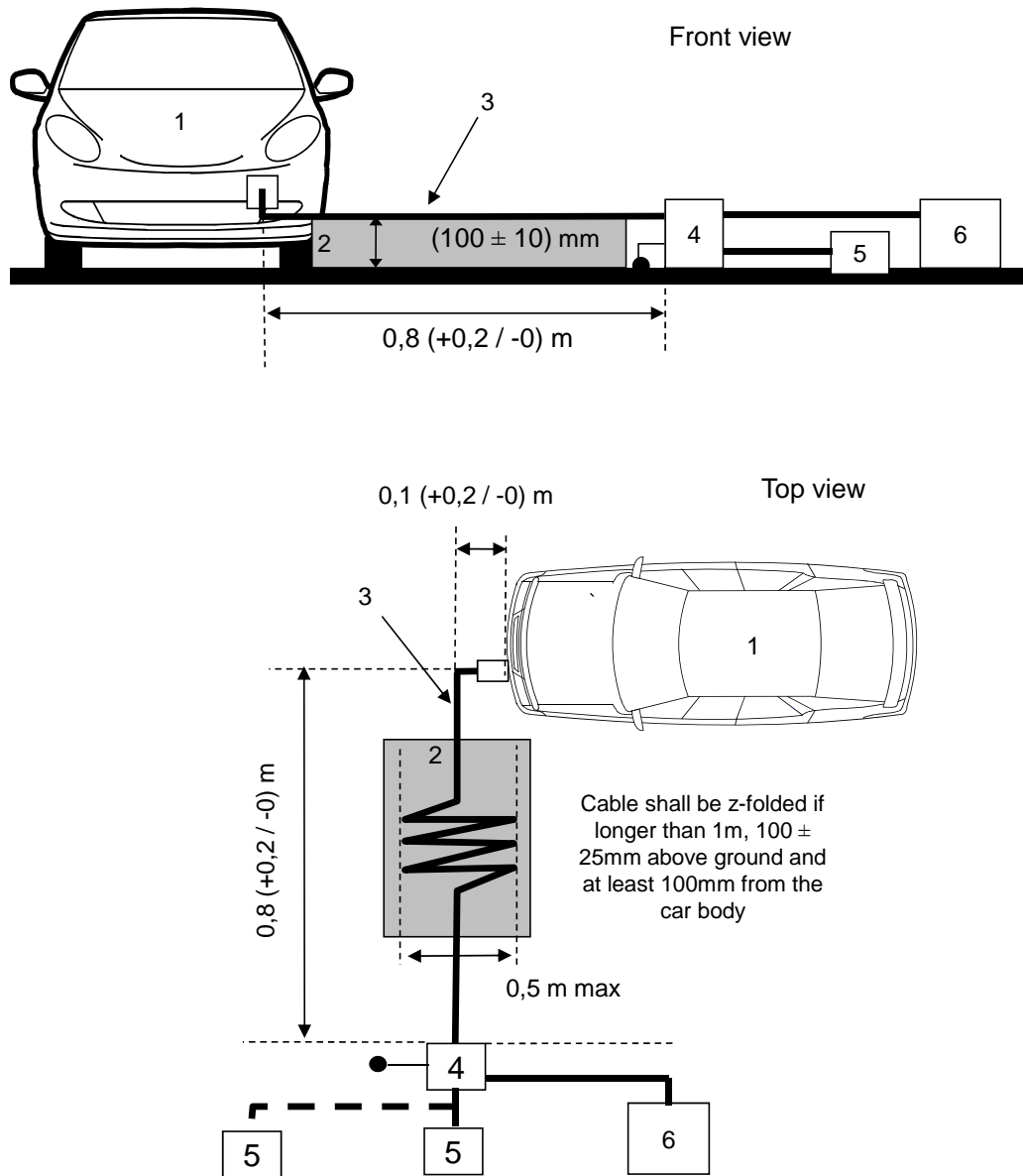

Key

- 1 Vehicle under test
- 2 Insulating support
- 3 Charging cable
- 4 Artificial Network(s) grounded (for AC or DC power lines)
- 5 Power mains socket
- 6 Measuring receiver

Figures 1c & 1d – Example of test setup for vehicle with plug located front / rear of vehicle (AC powered without communication)"

Annex 14, amend to read:

"Method(s) of testing for emission of radiofrequency conducted disturbances on network and telecommunication access from vehicles

1. General
 - 1.1. The test method described in this annex shall be applied to vehicles in configuration "REESS charging mode coupled to the power grid".
 - 1.2. Test method

This test is intended to measure the level of radio frequency conducted disturbances generated by vehicle in configuration "REESS charging mode coupled to the power grid" through its network and telecommunication access in order to ensure it is compatible with residential, commercial and light industrial environments.

If not otherwise stated in this annex the test shall be performed according to CISPR 22 (~~edition 6.0—2008~~).
2. Vehicle/ ~~ESA~~-state during tests
 - 2.1. The vehicle shall be in configuration "REESS charging mode coupled to the power grid" ~~at rated power until the AC or DC current reached at least 80 per cent of its initial value.~~ **The state of charge (SOC) of the traction battery shall be kept between 20 per cent and 80 per cent of the maximum SOC during the whole frequency range measurement (this may lead to split the measurement in different sub-bands with the need to discharge the vehicle's traction battery before starting the next sub-bands). If the current consumption can be adjusted, then the current shall be set to at least 80 per cent of its nominal value.**

The vehicle shall be immobilized, engine OFF.

And all other equipment which can be switched on permanently by the driver or passenger should be OFF.
3. Test arrangements
 - 3.1. The test set-up shall be performed according to CISPR 22, (~~edition 6.0—2008~~)-paragraph 5 for conducted emissions.
 - 3.2. The impedance stabilisation to be used for the measurement on vehicle is defined in CISPR 22 (~~edition 6.0—2008~~)-paragraph 9.6.2.

Impedance Stabilization

Communication lines shall be applied to the vehicle through IS(s).

The IS(s) shall be mounted directly on the ground plane. The case of the IS(s) shall be bonded to the ground plane.

The measuring port of each IS shall be terminated with a 50 Ω load. The IS shall be placed as defined in Figures 1a to 1d.

- 3.3. The test set-up for the connection of the vehicle in configuration “REESS charging mode coupled to the power grid” is shown in Figures 1a to 1d of Appendix 1 to this Annex.

If it is impossible to guarantee the functionality of vehicle, due to introduction of IS an alternate method described in CISPR 22 (according to Figure 2a to 2d of this annex) shall be applied.

- 3.4. The measurements shall be performed with a spectrum analyser or a scanning receiver. The parameters to be used are respectively defined in CISPR 25 Clause 4.4.1 (table 1) and 4.4.2 (table 2).

The measurements shall be performed with a spectrum analyser or a scanning receiver. The parameters to be used are defined in Table 1 and Table 2.

Table 1

Spectrum analyser parameters

Frequency range MHz	Peak detector		Quasi-peak detector		Average detector	
	RBW at -3 dB	Scan time	RBW at -6 dB	Scan time	RBW at -3 dB	Scan time
0.15 to 30 kHz	9/10 kHz	10 s/MHz	9 kHz	200 s/MHz	9/10 kHz	10 s/MHz

Note: If a spectrum is used for peak measurements, the video bandwidth shall be at least three times the resolution bandwidth (RBW)

Table 2

Scanning receiver parameters

Frequency range MHz	Peak detector			Quasi-peak detector			Average detector		
	BW at -6 dB	Step size ^a	Dwell time	BW at -6 dB	Step size ^a	Dwell time	BW at -6 dB	Step size ^a	Dwell time
0.15 to 30	9 kHz	5 kHz	50 ms	9 kHz	5 kHz	1 s	9 kHz	5 kHz	50 ms

a) For purely broadband disturbances, the maximum frequency step size may be increased up to a value not greater than the bandwidth value.

4. Test Requirements
- 4.1. The limits apply throughout the frequency range 0,15 to 30 MHz for measurements performed in a semi anechoic chamber or an outdoor test site.
- 4.2. Measurements shall be performed with average and either quasi-peak or peak detectors. The limits are given in paragraph 7.6. Table 4-9. If peak detectors are used a correction factor of 20 dB as defined in CISPR 12 (fifth edition 2001 and Amendment 1:2005) shall be applied."

Annex 14, Appendix 1, amend to read:

"Annex 14 – Appendix 1

Figure 1

Vehicle in configuration "REESS charging mode coupled to the power grid"

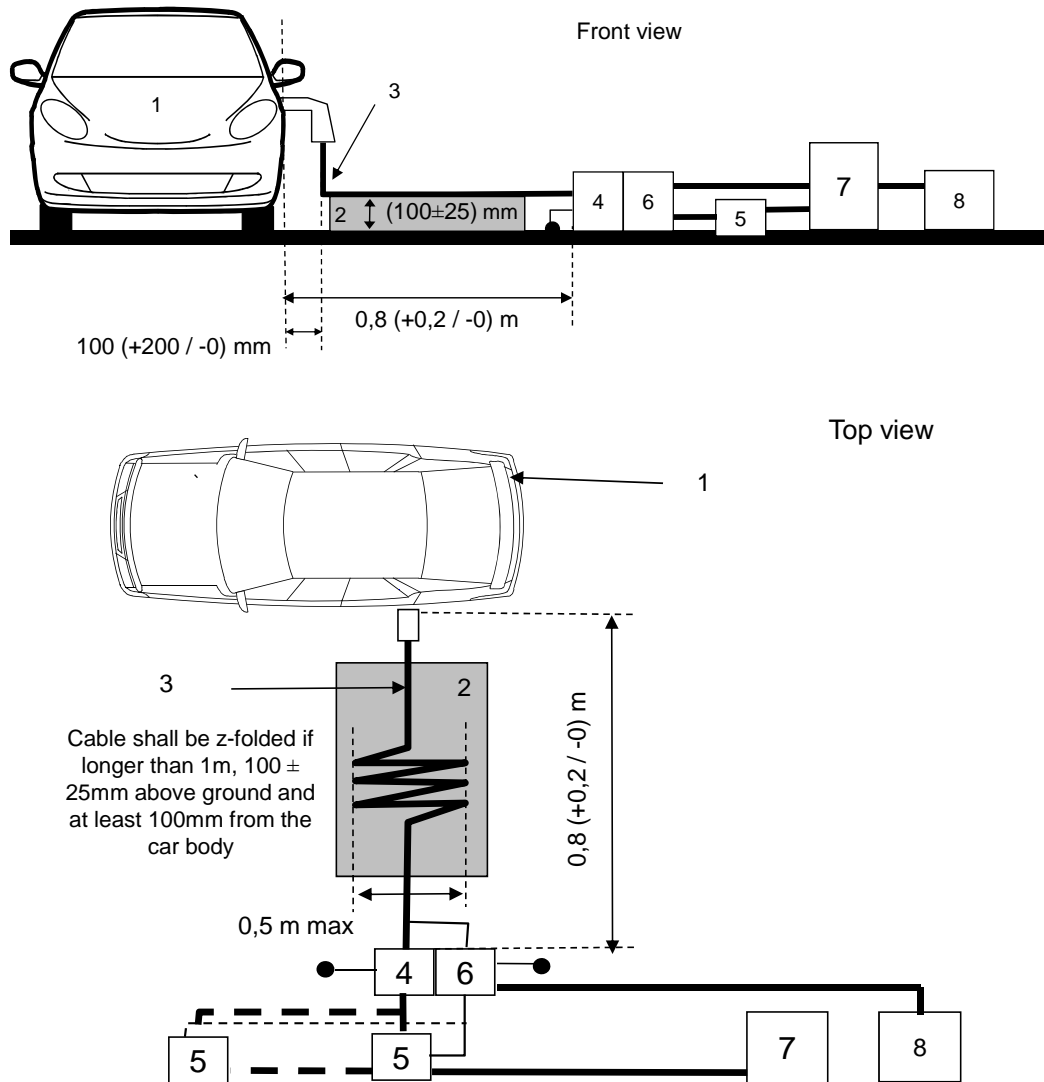

Key

1	Vehicle under test	5	Power mains socket
2	Insulating support	6	Impedance Stabilization(s) grounded (for communication lines)
3	Charging / communication cable	7	Charging Station
4	AC or DC Artificial Network(s) grounded (for AC or DC power lines)	8	Measuring receiver

Figures 1a & 1b – Example of test setup for vehicle with plug located on vehicle side (AC or DC powered with communication)

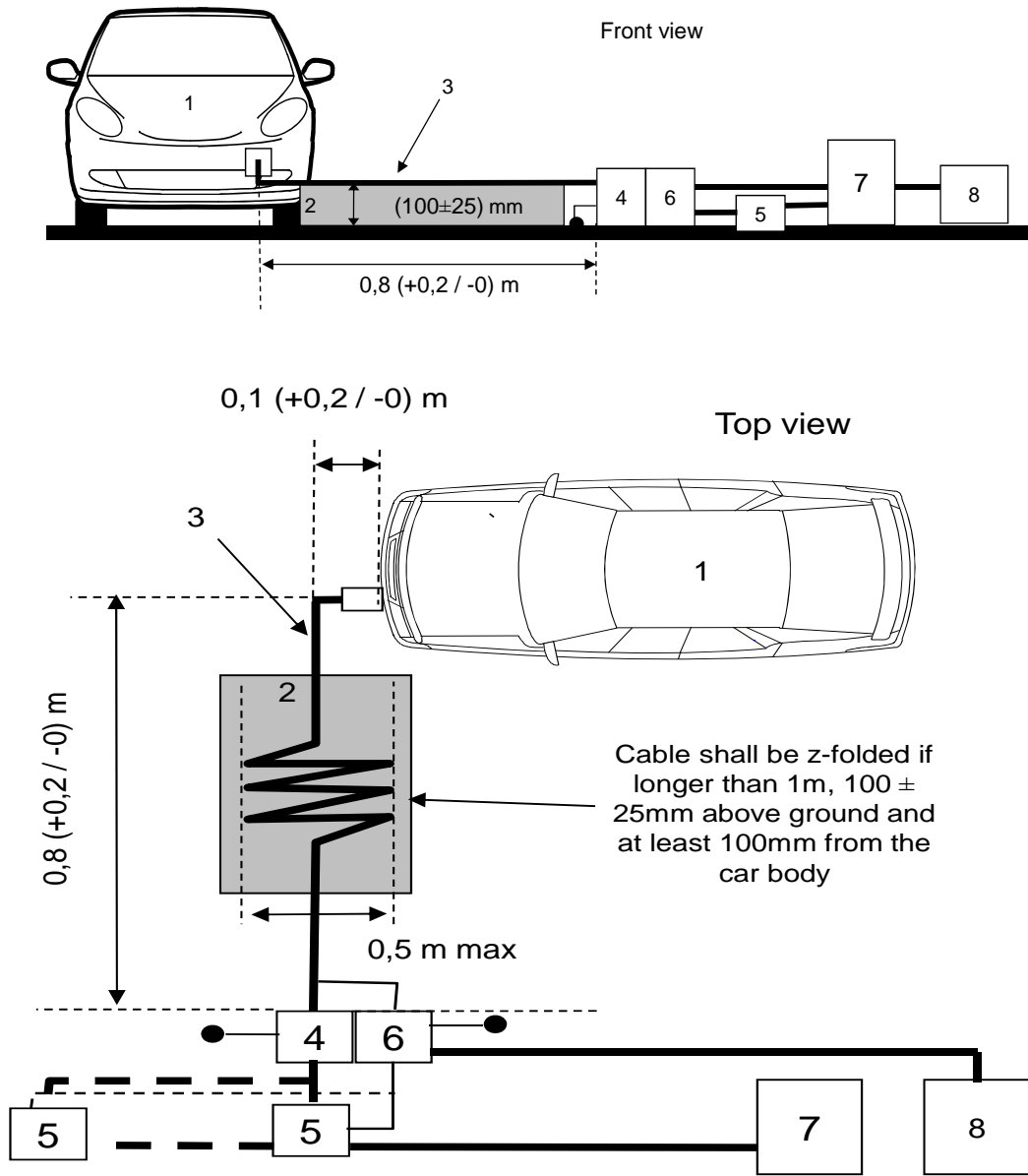

Key

1	Vehicle under test	5	Power mains socket
2	Insulating support	6	Impedance Stabilisation(s) grounded (for communication lines)
3	Charging / communication cable	7	Charging Station
4	AC or DC Artificial Network(s) grounded (for AC or DC power lines)	8	Measuring receiver

Figure 1c & 1d – Example of test set-up for vehicle with plug located front/rear of vehicle (AC or DC powered with communication)

Figure 2

Alternative measurement for vehicle in configuration "REESS charging mode coupled in the power grid"

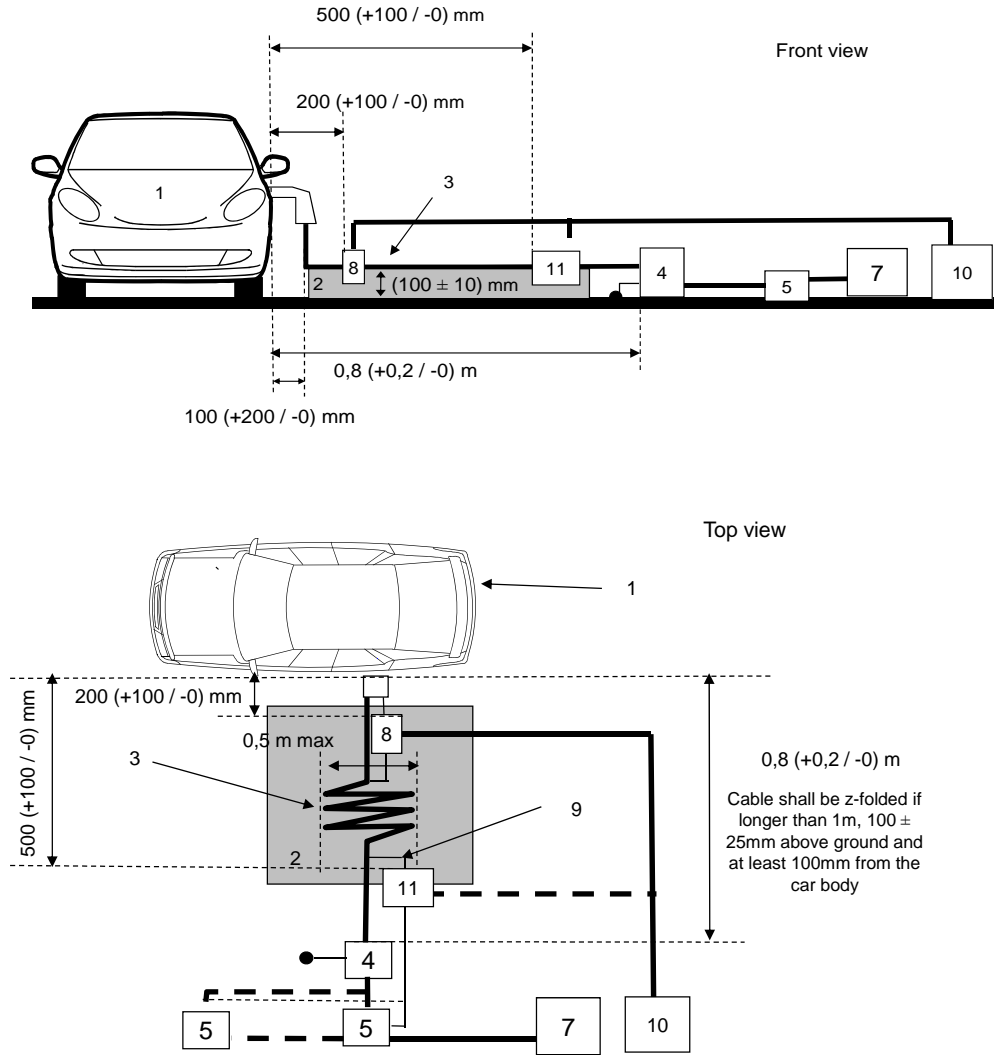

Key	5	Power mains socket	
1	Vehicle under test	7	Charging Station
2	Insulating support	8	Current probe
3	Charging / communication cable	9	Communication lines
4	AC or DC Artificial Network(s) grounded (for AC or DC power lines)	10	Measuring receiver
		11	Capacitive voltage probe

Figures 2a and 2b – Example of test setup for vehicle with plug located on vehicle side (AC or DC powered with communication) – Alternative measurement

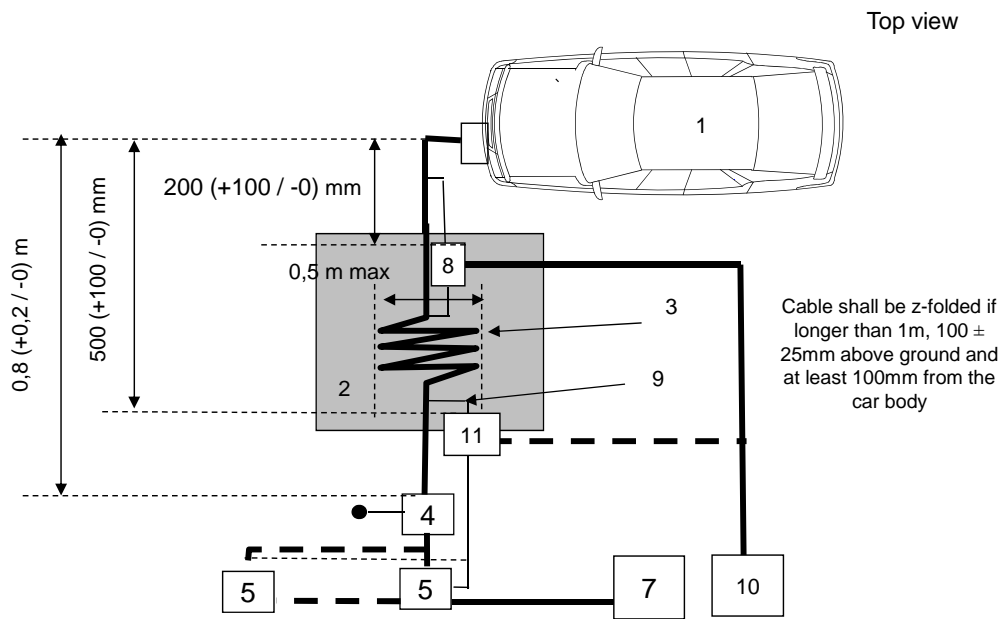
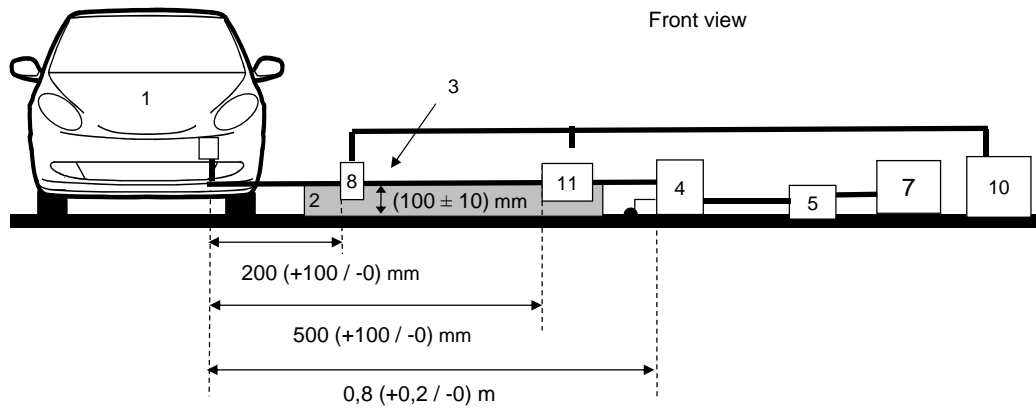

Key	5	Power mains socket	
1	Vehicle under test	7	Charging Station
2	Insulating support	8	Current probe (or capacitive voltage probe)
3	Charging / communication cable	9	Communication lines
4	AC or DC Artificial Network(s) grounded (for AC or DC power lines)	10	Measuring receiver
		11	Capacitive voltage probe

Figures 2c and 2d – Example of test setup for vehicle with plug located front / rear of vehicle (AC or DC powered with communication) – Alternative measurement

Annex 15, amend to read:

"Method of testing for immunity of vehicles to electrical fast transient/burst disturbances conducted along AC and DC power lines

1. General
 - 1.1. The test method described in this annex shall only be applied to vehicles. This method concerns only the configuration of the vehicle with "REESS in charging mode coupled to the power grid".
 - 1.2. Test method

This test is intended to demonstrate the immunity of the vehicle electronic systems. The vehicle shall be subject to electrical fast transient/burst disturbances conducted along AC and DC power lines of the vehicle as described in this annex. The vehicle shall be monitored during the tests.

If not otherwise stated in this annex the test shall be performed according to IEC 61000-4-4: ~~2nd edition 2004~~.
2. Vehicle state during tests in configuration "REESS in charging mode coupled to the power grid"
 - 2.1. The vehicle shall be in an unladen condition except for necessary test equipment.
 - 2.1.1. The vehicle shall be immobilized, engine OFF and in charging mode.
 - 2.1.2. Basic vehicle conditions

The paragraph defines minimum test conditions (as far as applicable) and failures criteria for vehicle immunity tests. Other vehicle systems, which can affect immunity related functions, must be tested in a way to be agreed between manufacturer and Technical Service.

"REESS in charging mode" vehicle test conditions

Failure criteria

The REESS shall be in charging mode. The REESS state of charge shall be agreed in between the manufacturer and the Technical Service (SOC). The SOC of the traction battery shall be kept between 20 per cent and 80 per cent of the maximum SOC during the whole frequency range measurement (this may lead to split the measurement in different sub-bands with the need to discharge the vehicle's traction battery before starting the next sub-bands). If the current consumption can be adjusted, then the current shall be set to at least 20 per cent of its nominal value.

Vehicle sets in motion

- 2.1.3. All other equipment which can be switched on permanently by the driver or passenger should be OFF.
- 2.2. Only non-perturbing equipment shall be used while monitoring the vehicle. The vehicle exterior and the passenger compartment shall be monitored to

determine whether the requirements of this annex are met (e.g. by using (a) video camera(s), a microphone, etc.).

3. Test equipments

3.1. The test equipments is composed of a reference ground plane (a shielded room is not required), a transient / burst generator, coupling / decoupling network (CDN) and capacitive coupling clamp.

3.2. The transient / burst generator shall meet the condition defined in paragraph 6.1 of IEC 61000-4-4, ~~2nd edition, 2004~~.

3.3. The coupling / decoupling network shall meet the condition defined in paragraph 6.2 of *IEC 61000-4-4*. ~~2nd edition, 2004~~. When the coupling/decoupling network cannot be used on AC or DC power lines, the capacitive coupling clamp defined in paragraph 6.3 of *IEC 61000-4-4*: ~~2nd edition, 2004~~ can be used.

4. TEST SETUP

4.1. The vehicle test setup is based on the laboratory type setup as described in paragraph 7.2 of *IEC 61000-4-4*: ~~2nd edition, 2004~~.

4.2. The vehicle shall be placed directly on the ground plane.

4.3. The Technical Service shall perform the test as specified in paragraph 7.7.2.1. Alternatively, if the manufacturer provides measurement from a test laboratory accredited to the applicable parts of *ISO 17025 (second edition 2005 and Corrigendum:2006)* and recognized by the Approval Authority, the Technical Service may choose not to perform the test to confirm that the vehicle meets the requirements of this Annex.

5. GENERATION OF REQUIRED TEST LEVEL

5.1. Test methodology

5.1.1. The test method according to *IEC 61000-4-4*, ~~2nd edition, 2004~~ shall be used to establish the test level requirements.

5.1.2. Test phase

The vehicle shall be positioned on the ground plane. The electrical fast transient/burst (EFT/B) shall be applied on the vehicle on the AC/DC power lines in common modes by using CDN as described in Appendix 1, Figure 1 of this annex.

The test set-up must be noted in the test report.

Annex 15, Appendix 1, amend to read:

"Annex 15 – Appendix 1

Figure 1

Vehicle in configuration "REESS charging mode" coupled to the power grid coupling on AC/DC power lines

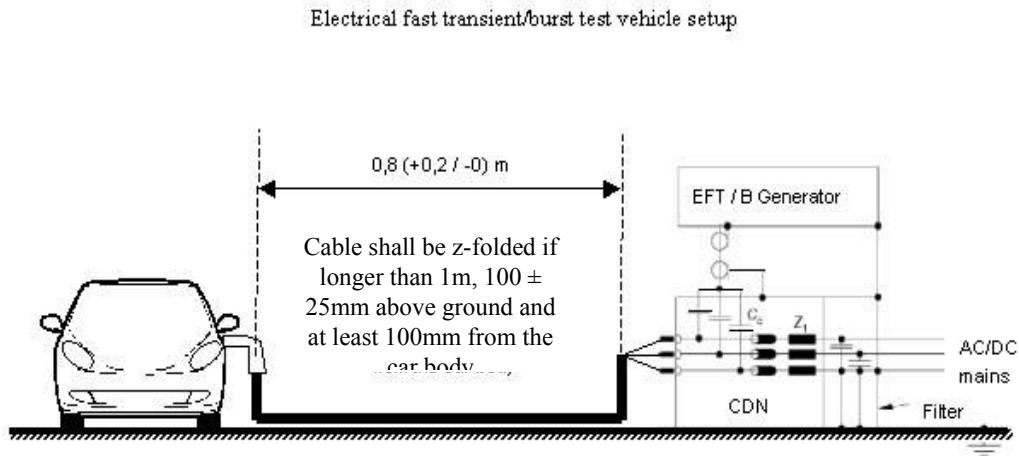

Annex 16, amend to read:

"Method of testing for immunity of vehicles to surges conducted along AC and DC power lines

1. General
 - 1.1. The test method described in this annex shall only be applied to vehicles. This method concerns only the configuration of the vehicle with "REESS in charging mode coupled to the power grid".
 - 1.2. Test method

This test is intended to demonstrate the immunity of the vehicle electronic systems. The vehicle shall be subject to surges conducted along AC and DC power lines of the vehicle as described in this annex. The vehicle shall be monitored during the tests.

If not otherwise stated in this annex the test shall be performed according to IEC 61000-4-5- 2nd edition 2005.
2. Vehicle state during tests in configuration "REESS in charging mode coupled to the power grid"
 - 2.1. The vehicle shall be in an unladen condition except for necessary test equipment.
 - 2.1.1. The vehicle shall be immobilized, engine OFF and in charging mode.

2.1.2. Basic vehicle conditions

The paragraph defines minimum test conditions (as far as applicable) and failures criteria for vehicle immunity tests. Other vehicle systems, which can affect immunity related functions, must be tested in a way to be agreed between manufacturer and Technical Service.

"REESS in charging mode" vehicle test conditions

Failure criteria

<p>The REESS shall be in charging mode. The REESS state of charge shall be agreed in between the manufacturer and the Technical Service. (SOC). The SOC of the traction battery shall be kept between 20 per cent and 80 per cent of the maximum SOC during the whole frequency range measurement (this may lead to split the measurement in different sub-bands with the need to discharge the vehicle's traction battery before starting the next sub-bands). If the current consumption can be adjusted, then the current shall be set to at least 20 per cent of its nominal value.</p>	<p>Vehicle sets in motion</p>
---	-------------------------------

2.1.3. All other equipment which can be switched on permanently by the driver or passenger should be OFF.

2.2. Only non-perturbing equipment shall be used while monitoring the vehicle. The vehicle exterior and the passenger compartment shall be monitored to determine whether the requirements of this annex are met (e.g. by using (a) video camera(s), a microphone, etc.).

3. Test equipments

3.1. The test equipments is composed of a reference ground plane (a shielded room is not required), a surge generator and a coupling / decoupling network (CDN).

3.2. The surge generator shall meet the condition defined in paragraph 6.1 of IEC 61000-4-5: ~~2nd edition 2005~~.

3.3. The coupling/decoupling network shall meet the condition defined in paragraph 6.3 of IEC 61000-4-5: ~~2nd edition 2005~~.

4. Test setup

4.1. The vehicle test setup is based on the setup described in paragraph 7.2 of IEC 61000-4-5: ~~2nd edition 2005~~.

4.2. The vehicle shall be placed directly on the ground plane.

4.3. The Technical Service shall perform the test as specified in paragraph 7.8.2.1. Alternatively, if the manufacturer provides measurement from a test laboratory accredited to the applicable parts of ISO 17025 (~~second edition 2005 and Corrigendum 2006~~) and recognized by the Approval Authority, the Technical Service may choose not to perform the test to confirm that the vehicle meets the requirements of this annex.

5. Generation of required test level
 - 5.1. Test methodology
 - 5.1.1. The test method according to IEC 61000-4-5: ~~2nd edition 2005~~ shall be used to establish the test level requirements.
 - 5.1.2. Test phase

The vehicle shall be positioned on the ground plane. The electrical surge shall be applied on the vehicle on the AC/DC power lines between each line and earth and between lines by using CDN as described in Appendix 1, Figure 1 to 4 of this annex,

The test setup must be noted in the test report."

Annex 16, Appendix 1, amend to read:

"Annex 16 – Appendix 1

Vehicle in configuration "REESS charging mode coupled to the power grid"

Figure 1

Vehicle in configuration "REESS charging mode coupled to the power grid" – Coupling between lines for DC or AC (single phase) power lines

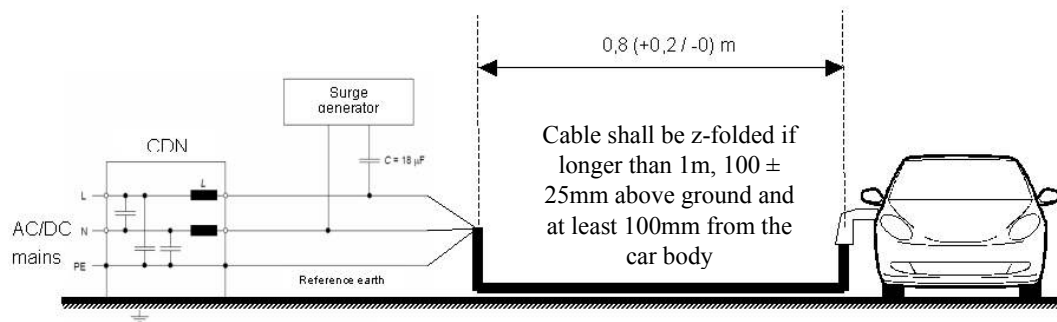

Figure 2

Vehicle in configuration "REESS charging mode coupled to the power grid" – Coupling between each line and earth for DC or AC (single phase) power lines

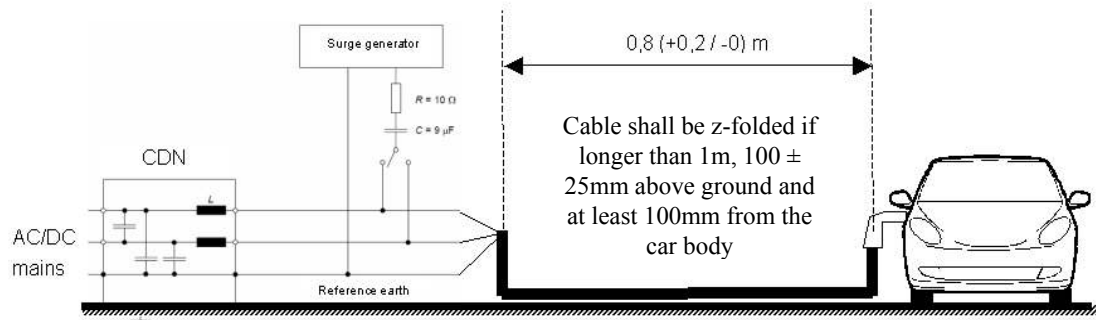

Figure 3
 Vehicle in configuration "REESS charging mode coupled to the power grid" – Coupling between lines for AC (three phases) power lines

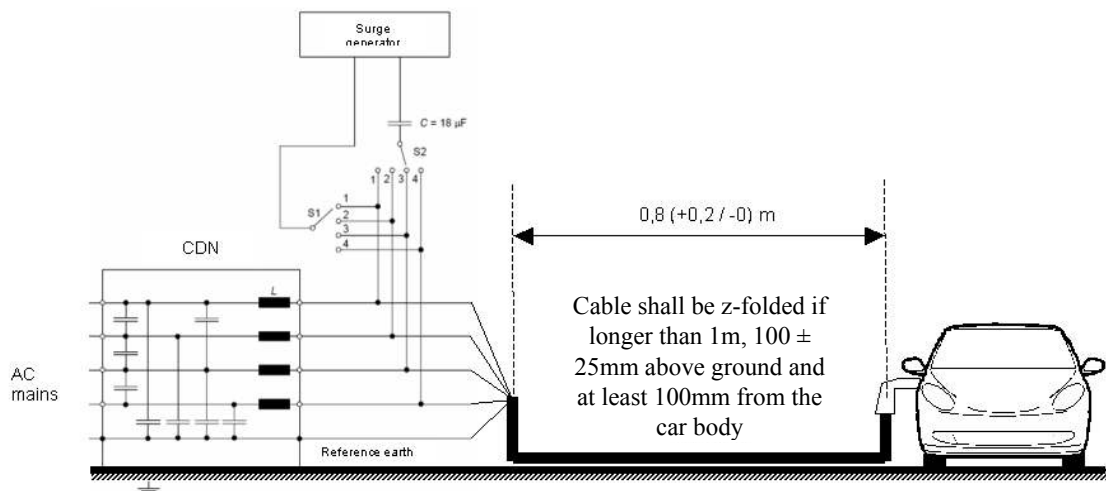
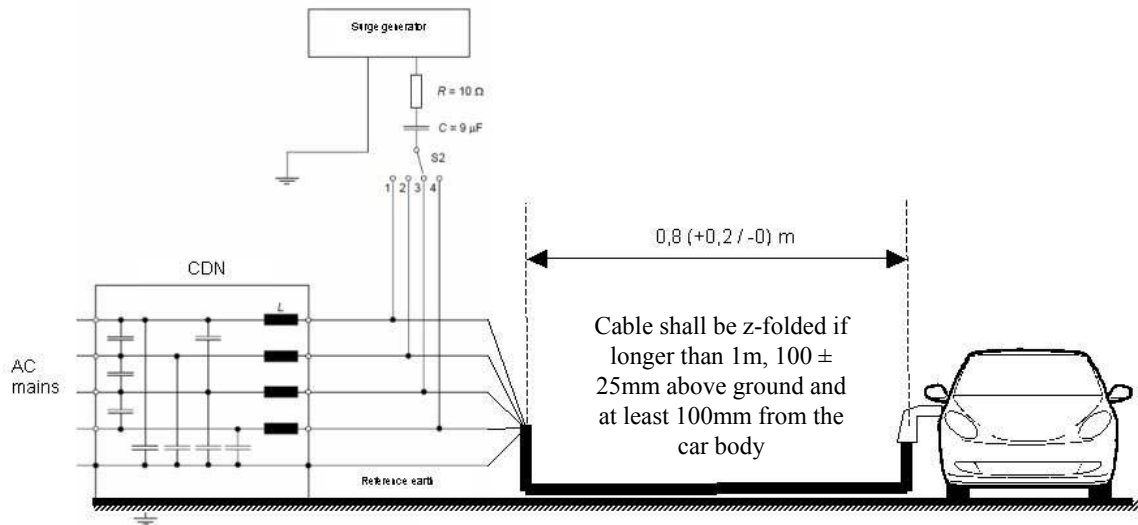

Figure 4
 Vehicle in configuration "REESS charging mode coupled to the power grid" – Coupling between each line and earth for AC (three phases) power lines



Insert new Annexes 17 to 22 and their Appendices, to read:

"Annex 17

Method(s) of testing for emission of harmonics generated on AC power lines from an ESA

1. General

1.1. The test method described in this annex shall be applied to ESAs in configuration "REESS charging mode coupled to the power grid"

1.2. Test method

This test is intended to measure the level of harmonics generated by an ESA in configuration "REESS charging mode coupled to the power grid" through its AC power lines in order to ensure it is compatible with residential, commercial and light industrial environments.

If not otherwise stated in this annex the test shall be performed according to:

- (a) IEC 61000-3-2 for input current in charging mode ≤ 16 A per phase for class A equipment;
- (b) IEC 61000-3-12 for input current in charging mode > 16 A and ≤ 75 A per phase.

2. ESA state during tests

2.1. The ESA shall be in configuration "REESS charging mode coupled to the power grid".

The state of charge (SOC) of the traction battery shall be kept between 20 per cent and 80 per cent of the maximum SOC during the whole frequency range measurement (this may lead to split the measurement in different sub-bands with the need to discharge the vehicle's traction battery before starting the next sub-bands)

If the test is not performed with a REESS the ESA should be tested at rated current. If the current consumption can be adjusted, then the current shall be set to at least 80 percent of its nominal value.

3. Test arrangements
 - 3.1. The observation time to be used for the measurements shall be as for quasi-stationary equipment as defined in IEC 61000-3-2 Table 4.
 - 3.2. The test set-up for single phase ESA in configuration "REESS charging mode coupled to the power grid" is shown in Figure 1 of Appendix 1 to this annex.
 - 3.3. The test set-up for three-phase ESA in configuration "REESS charging mode coupled to the power grid" is shown in Figure 2 of Appendix 1 to this annex.
4. Test requirements
 - 4.1. The measurements of even and odd current harmonics shall be performed up to the 40th harmonic.
 - 4.2. The limits for single phase or three-phase ESAs in configuration "REESS charging mode coupled to the power grid" with input current ≤ 16 A per phase are given in paragraph 7.11.2.1., Table 10.
 - 4.3. The limits for single phase ESAs in configuration "REESS charging mode coupled to the power grid" with input current > 16 A and ≤ 75 A per phase are given in paragraph 7.11.2.2., Table 11.
 - 4.4. The limits for three-phase ESAs in configuration "REESS charging mode coupled to the power grid" with input current > 16 A and ≤ 75 A per phase are given in paragraph 7.11.2.2., Table 12.
 - 4.5. For three-phase ESAs in configuration "REESS charging mode coupled to the power grid" with input current > 16 A and ≤ 75 A per phase, when at least one of the three conditions a), b), c) described in IEC 61000-3-12 Clause 5.2, is fulfilled then the limits given in paragraph 7.11.2.2., Table 13 can be applied.

Annex 17 – Appendix 1

Figure 1
ESA in configuration "REESS charging mode coupled to the power grid" – Single phase test set-up

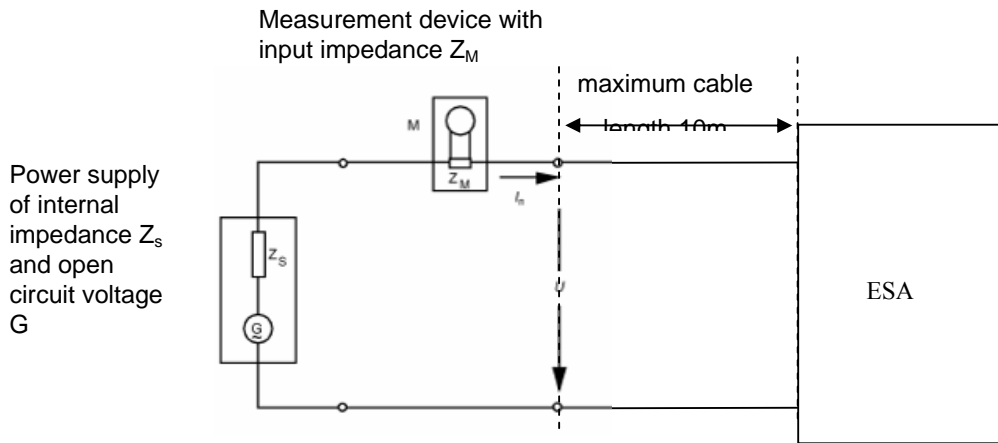
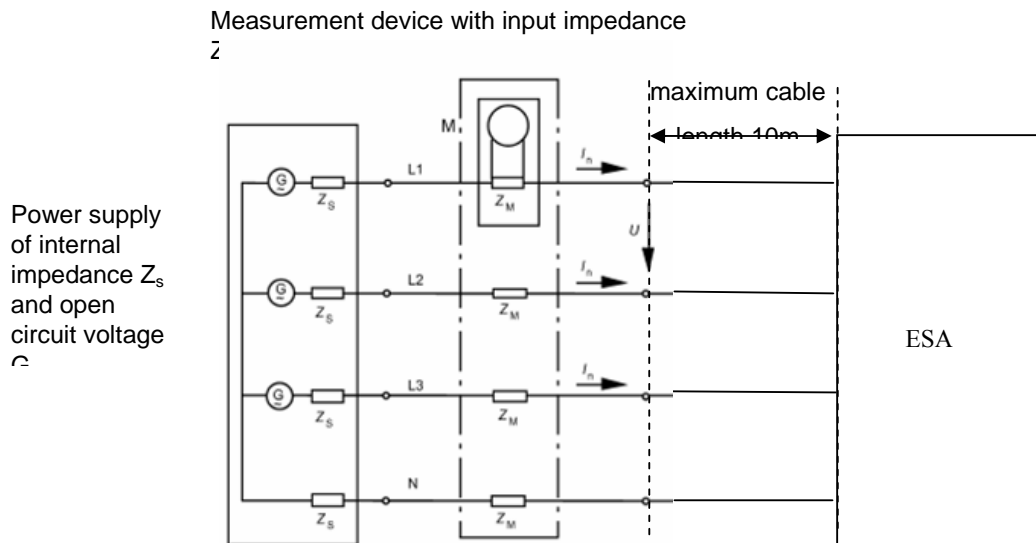

Figure 1
ESA in configuration "REESS charging mode coupled to the power grid" -Three-phase-test set-up



Annex 18

Method(s) of testing for emission of voltage changes, voltage fluctuations and flicker on AC power lines from an ESA

1. General
 - 1.1. The test method described in this annex shall be applied to ESAs in configuration “REESS charging mode coupled to the power grid”
 - 1.2. Test method

This test is intended to measure the level of voltage changes, voltage fluctuations and flicker generated by ESA in configuration “REESS charging mode coupled to the power grid” through its AC power lines in order to ensure it is compatible with residential, commercial and light industrial environments.

If not otherwise stated in this annex the test shall be performed according to:

 - (a) IEC 61000-3-3 for rated current in “REESS charging mode” ≤ 16 A per phase and not subjected to conditional connection
 - (b) IEC 61000-3-11 for rated current in “REESS charging mode” > 16 A and ≤ 75 A per phase and subjected to conditional connection
2. ESA state during tests
 - 2.1. The ESA shall be in configuration “REESS charging mode coupled to the power grid”

The state of charge (SOC) of the traction battery shall be kept between 20 per cent and 80 per cent of the maximum SOC during the whole frequency range measurement (this may lead to split the measurement in different sub-bands with the need to discharge the vehicle’s traction battery before starting the next sub-bands).

If the test is not performed with a REESS the ESA should be tested at rated current. If the current consumption can be adjusted, then the current shall be set to at least 80 per cent of its nominal value.
3. Test Arrangements
 - 3.1. The tests for ESA in configuration “REESS charging mode coupled to the power grid” with rated current ≤ 16 A per phase and not subjected to conditional connection shall be performed according IEC 61000-3-3 paragraph 4.
 - 3.2. The tests for ESA in configuration “REESS charging mode coupled to the power grid” with rated current > 16 A and ≤ 75 A per phase and subjected to conditional connection shall be performed according IEC 61000-3-11 paragraph 6.
 - 3.3. The test set-up for ESA in configuration “REESS charging mode coupled to the power grid” is shown in Figure 1a and 1b of Appendix 1 to this Annex.

4. Test requirements
 - 4.1. The parameters to be determined in the time-domain are “short duration flicker value”, “long duration flicker value” and “voltage relative variation”.
 - 4.2. The limits for ESA in configuration “REESS charging mode coupled to the power grid” with input current ≤ 16 A per phase and not subjected to conditional connection are given in paragraph 7.12.2.1. ~~Table 10.~~
 - 4.3. The limits for ESA in configuration “REESS charging mode coupled to the power grid” with input current > 16 A and ≤ 75 A per phase and subjected to conditional connection are given in paragraph 7.12.2.2. ~~Table 11, 12 and 13.~~

Annex 18 – Appendix 1

Figure 1a

ESA in configuration “REESS charging mode coupled to the power grid”- Single phase test set-up

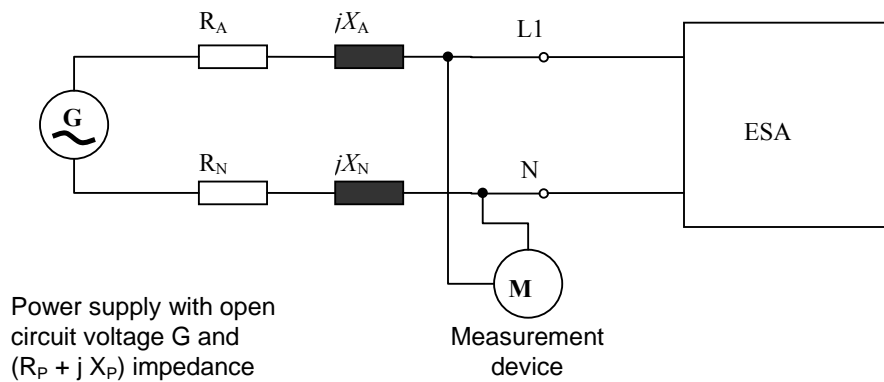
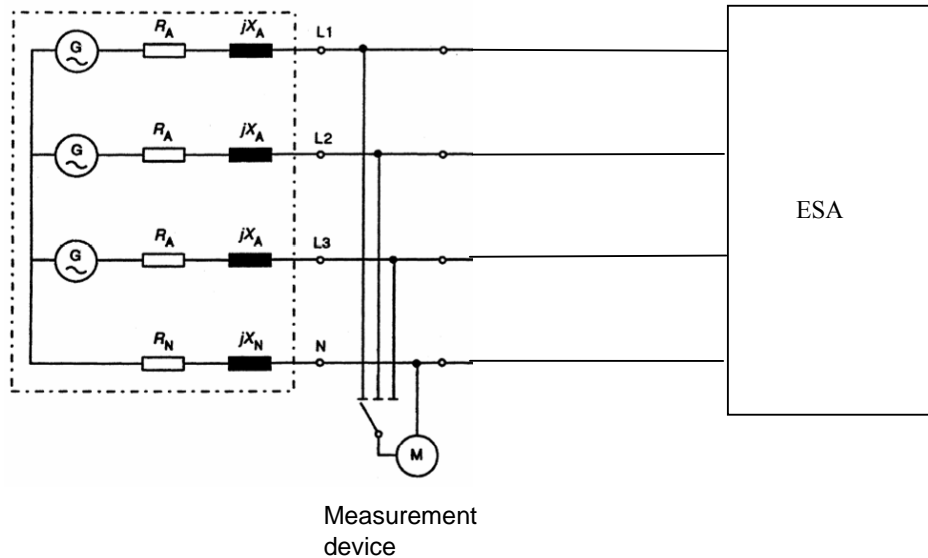

Figure 1b

ESA in configuration “REESS charging mode coupled to the power grid” - Three-phase test set-up

Power supply with open circuit
voltage G and $(R_P + j X_P)$
impedance



Annex 19

Method(s) of testing for emission of radiofrequency conducted disturbances on AC or DC power lines from an ESA

1. General

1.1. The test method described in this annex shall be applied to ESAs in configuration “REESS charging mode coupled to the power grid”.

1.2. Test method

This test is intended to measure the level of radio frequency conducted disturbances generated by ESA in configuration “REESS charging mode coupled to the power grid” through its AC or DC power lines in order to ensure it is compatible with residential, commercial and light industrial environments.

If not otherwise stated in this annex the test shall be performed according to CISPR 16-2-1.

2. ESA state during tests

2.1. The ESA shall be in configuration “REESS charging mode coupled to the power grid”.

The state of charge (SOC) of the traction battery shall be kept between 20 per cent and 80 per cent of the maximum SOC during the whole frequency range measurement (this may lead to split the measurement in different sub-bands with the need to discharge the vehicle’s traction battery before starting the next sub-bands).

If the test is not performed with a REESS the ESA should be tested at rated current. If the current consumption can be adjusted, then the current shall be set to at least 80 per cent of its nominal value.

- 3. Test arrangements
 - 3.1. The test shall be performed according to CISPR 16-2-1, Clause 7.4.1. as table-standing equipments.
 - 3.2. The artificial mains network to be used for the measurement on vehicle components is defined in CISPR 16-1-2, Clause 4.3

Artificial networks

The AN(s) shall be mounted directly on the ground plane. The cases of the AN(s) shall be bonded to the ground plane.

The measuring port of each AN shall be terminated with a 50 Ω load.

The AN shall be placed in front, aligned and on the same side of the vehicle power charging plug.

- 3.3. The test set-up for the connection of the ESAs in configuration “REESS charging mode coupled to the power grid” is shown in Figure 2 of Appendix 1 to this Annex.
- 3.4. The measurements shall be performed with a spectrum analyser or a scanning receiver. The parameters to be used are defined in Table 1 and Table 2.

Table 1
Spectrum analyser parameters

<i>Frequency range MHz</i>	<i>Peak detector</i>		<i>Quasi-peak detector</i>		<i>Average detector</i>	
	<i>RBW at -3 dB</i>	<i>Scan time</i>	<i>RBW at -6 dB</i>	<i>Scan time</i>	<i>RBW at -3 dB</i>	<i>Scan time</i>
0.15 to 30	9/10 kHz	10 s / MHz	9 kHz	200 s / MHz	9/10 kHz	10 s / MHz

Note: If a spectrum is used for peak measurements, the video bandwidth shall be at least three times the resolution bandwidth (RBW)

Table 2
Scanning receiver parameters

<i>Frequency range MHz</i>	<i>Peak detector</i>			<i>Quasi-peak detector</i>			<i>Average detector</i>		
	<i>BW at -6 dB</i>	<i>Step size^{a)}</i>	<i>Dwell time</i>	<i>BW at -6 dB</i>	<i>Step size^{a)}</i>	<i>Dwell time</i>	<i>BW at -6 dB</i>	<i>Step size^{a)}</i>	<i>Dwell time</i>

Frequency range MHz	Peak detector			Quasi-peak detector			Average detector		
	BW at -6 dB	Step size ^{a)}	Dwell time	BW at -6 dB	Step size ^{a)}	Dwell time	BW at -6 dB	Step size ^{a)}	Dwell time
0.15 to 30	9 kHz	5 kHz	50 ms	9 kHz	5 kHz	1 s	9 kHz	5 kHz	50 ms

a) For purely broadband disturbances, the maximum frequency step size may be increased up to a value not greater than the bandwidth value.

Note: For emissions generated by brush commutator motors without an electronic control unit, the maximum step size may be increased up to 5 times the bandwidth.

4. Test Requirements

4.1 The limits apply throughout the frequency range 0,15 to 30 MHz for measurements performed in a semi anechoic chamber or an outdoor test site.

4.2 Measurements shall be performed with average and either quasi-peak or peak detectors. The limits are given in paragraph 7.13.2.1 Table 14 for AC lines and paragraph 7.13.2.2 Table 15 for DC lines. If peak detectors are used a correction factor of 20 dB as defined in *CISPR 12* shall be applied.

Annex 19 – Appendix 1

Figure 1

ESA in configuration “REESS charging mode coupled to the power grid”

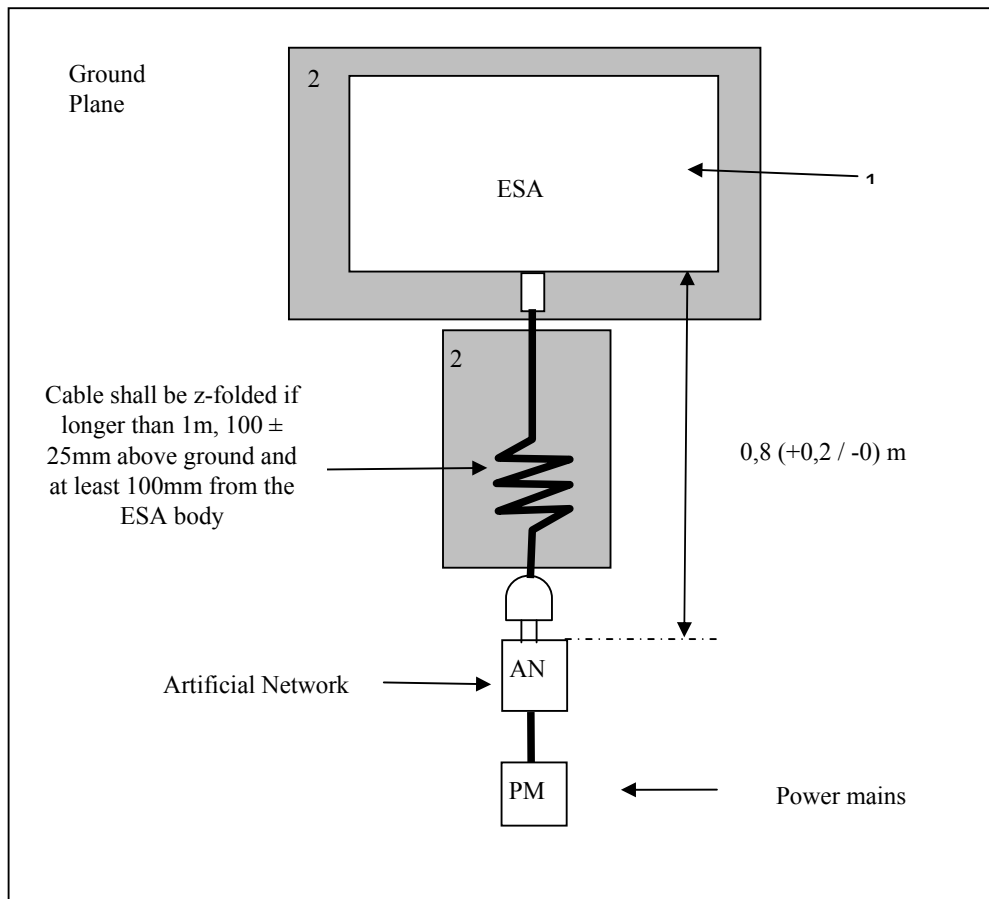
**Key**

- 1 ESA under test
- 2 Insulating support
- 3 Charging cable
- 4 AC or DC Artificial Network(s) grounded
- 5 Power mains socket
- 6 Measuring receiver

Annex 20

Method(s) of testing for emission of radiofrequency conducted disturbances on network and telecommunication access from an ESA

1. **General**
 - 1.1. The test method described in this annex shall be applied to ESAs in configuration “REESS charging mode coupled to the power grid”.
 - 1.2. **Test method**

This test is intended to measure the level of radio frequency conducted disturbances generated by ESA in configuration “REESS charging mode coupled to the power grid” through its network and telecommunication access in order to ensure it is compatible with residential, commercial and light industrial environments.

If not otherwise stated in this annex the test shall be performed according to CISPR 22.
2. **ESA state during tests**
 - 2.1. The ESA shall be in configuration “REESS charging mode coupled to the power grid”.

The state of charge (SOC) of the traction battery shall be kept between 20 per cent and 80 per cent of the maximum SOC during the whole frequency range measurement (this may lead to split the measurement in different sub-bands with the need to discharge the vehicle’s traction battery before starting the next sub-bands).

If the test is not performed with a REESS the ESA should be tested at rated current. If the current consumption can be adjusted, then the current shall be set to at least 80 per cent of its nominal value.
3. **Test arrangements**
 - 3.1. The test set-up shall be performed according to CISPR 22 paragraph 5 for conducted emissions.
 - 3.2. The impedance stabilization to be used for the measurement on ESA is defined in CISPR 22 paragraph 9.6.2.

Impedance Stabilization

Communication lines shall be applied to the vehicle through IS(s).

The impedance stabilization (IS) to be connected in the network and communication cables is defined in CISPR 22 paragraph 9.6.2.

The IS(s) shall be mounted directly on the ground plane. The case of the IS(s) shall be bonded to the ground plane.

The measuring port of each IS shall be terminated with a 50 Ω load.

The IS shall be placed in front, aligned and on the same side of the vehicle power charging plug.

- 3.3. The test set-up for the connection of the ESA in configuration “REESS charging mode coupled to the power grid” is shown in Figure 1 of Appendix 1 to this annex.
- 3.5. The measurements shall be performed with a spectrum analyser or a scanning receiver. The parameters to be used are defined in Table 1 and Table 2.

Table 1
Spectrum analyser parameters

Frequency range MHz	Peak detector		Quasi-peak detector		Average detector	
	RBW at -3 dB	Scan time	RBW at -6 dB	Scan time	RBW at -3 dB	Scan time
0.15 to 30	9/10 kHz	10 s / MHz	9 kHz	200 s / MHz	9/10 kHz	10 s / MHz

Note: If a spectrum is used for peak measurements, the video bandwidth shall be at least three times the resolution bandwidth (RBW)

Table 2
Scanning receiver parameters

Frequency range MHz	Peak detector			Quasi-peak detector			Average detector		
	BW at -6 dB	Step size ^{a)}	Dwell time	BW at -6 dB	Step size ^{a)}	Dwell time	BW at -6 dB	Step size ^{a)}	Dwell time
0.15 to 30	9 kHz	5 kHz	50 ms	9 kHz	5 kHz	1 s	9 kHz	5 kHz	50 ms

a) For purely broadband disturbances, the maximum frequency step size may be increased up to a value not greater than the bandwidth value.

Note: For emissions generated by brush commutator motors without an electronic control unit, the maximum step size may be increased up to 5 times the bandwidth.

4. Test Requirements

- 4.1. The limits apply throughout the frequency range 0.15 to 30 MHz for measurements performed in a semi anechoic chamber or an outdoor test site.
- 4.2. Measurements shall be performed with average and either quasi-peak or peak detectors. The limits are given in paragraph 7.14.2.1 Table 16. If peak detectors are used a correction factor of 20 dB as defined in CISPR 12 shall be applied.

Annex 20 – Appendix 1

Figure 1

ESA in configuration "REESS charging mode coupled to the power grid"

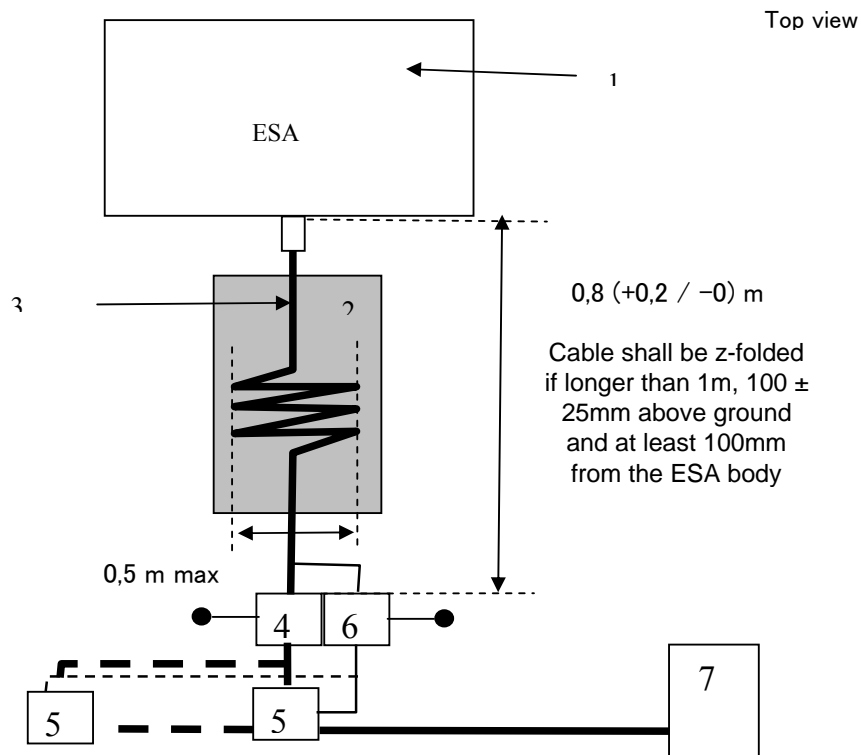

Key

- 1 ESA under test
- 2 Insulating support
- 3 Charging / communication cable
- 4 AC or DC Artificial Network(s) grounded
- 5 Power mains socket
- 6 Impedance Stabilization(s) grounded
- 7 Charging Station

Annex 21

Method of testing for immunity of an ESA to electrical fast transient/burst disturbances conducted along AC and DC power lines

1. General
 - 1.1. The test method described in this annex shall only be applied to ESAs. This method applies only to ESA in configuration “REESS charging mode coupled to the power grid”.
 - 1.2. Test method

This test is intended to demonstrate the immunity of the ESA. The ESA shall be subject to electrical fast transient/burst disturbances conducted along AC and DC power lines of the ESA as described in this annex. The ESA shall be monitored during the tests.

If not otherwise stated in this annex the test shall be performed according to IEC 61000-4-4.
 2. ESA state during tests in configuration “REESS in charging mode coupled to the power grid”
 - 2.1. Basic ESA conditions

The paragraph defines minimum test conditions (as far as applicable) and failures criteria for ESA immunity tests.

<i>"REESS charging mode" ESA test conditions</i>	<i>Failure criteria</i>
<p>ESA shall be in configuration “REESS charging mode coupled to the power grid”.</p> <p>The state of charge (SOC) of the traction battery shall be kept between 20 per cent and 80 per cent of the maximum SOC during the whole frequency range measurement (this may lead to split the measurement in different sub-bands with the need to discharge the vehicle’s traction battery before starting the next sub-bands).</p> <p>If the test is not performed with a REESS the ESA should be tested at rated current. If the current consumption can be adjusted, then the current shall be set to at least 20 per cent of its nominal value.</p>	<p>incorrect charging condition (e.g. over-current, overvoltage)</p>

- 2.2. Only non-perturbing equipment shall be used while monitoring the ESA. The ESA shall be monitored to determine whether the requirements of this Annex are met (e.g. by using (a) video camera(s), a microphone, etc.).
3. Test equipments

- 3.1. The test equipments is composed of a reference ground plane (a shielded room is not required), a transient / burst generator, coupling / decoupling network (CDN) and capacitive coupling clamp.
- 3.2. The transient/burst generator shall meet the condition defined in paragraph 6.1 of IEC 61000-4-4.
- 3.3. The coupling/decoupling network shall meet the condition defined in paragraph 6.2 of IEC 61000-4-4. When the coupling/decoupling network cannot be used on AC or DC power lines, the capacitive coupling clamp defined in paragraph 6.3 of IEC 61000-4-4, can be used.
4. Test setup
 - 4.1. The ESA test setup is based on the laboratory type setup as described in paragraph 7.2 of IEC 61000-4-4.
 - 4.2. The ESA shall be placed directly on the ground plane.
 - 4.3. The Technical Service shall perform the test as specified in paragraph 7.15.2.1.

Alternatively, if the manufacturer provides measurement from a test laboratory accredited to the applicable parts of ISO 17025 and recognized by the Approval Authority, the Technical Service may choose not to perform the test to confirm that the ESA meets the requirements of this annex.
5. Generation of required test level
 - 5.1. Test methodology
 - 5.1.1. The test method according to IEC 61000-4-4 shall be used to establish the test level requirements.
 - 5.1.2. Test phase

The ESA shall be positioned on the ground plane. The electrical fast transient / burst (EFT/B) shall be applied on the ESA on the AC/DC power lines in common modes by using CDN as described in Appendix 1, Figure 1 of this annex,

The test setup must be noted in the test report.

Annex 21 – Appendix 1

Figure 1
 ESA in configuration “REESS charging mode coupled to the power grid

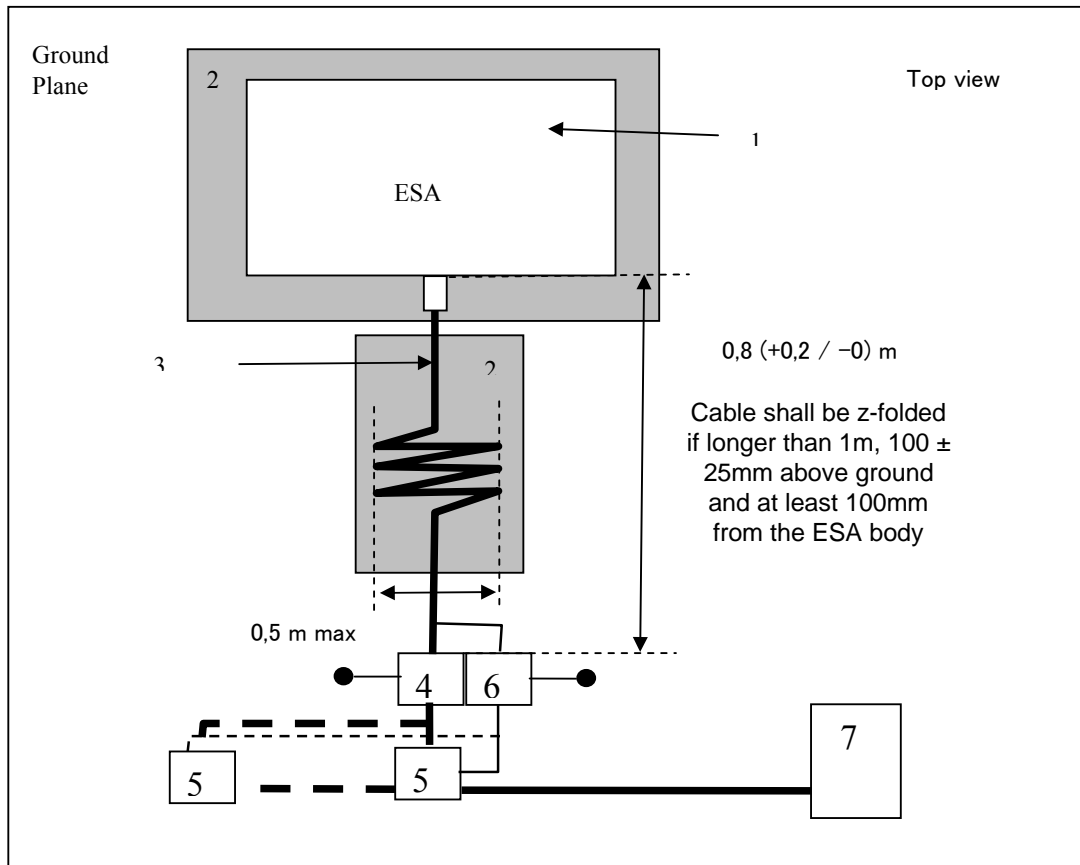

Annex 22

Method of testing for immunity of ESAs to surges conducted along AC and DC power lines

1. General
 - 1.1. The test method described in this annex shall only be applied to ESAs. This method applies only to ESAs in configuration “REESS charging mode coupled to the power grid”.
 - 1.2. Test method

This test is intended to demonstrate the immunity of the ESA. The ESA shall be subject to surges conducted along AC and DC power lines of the ESA as described in this annex. The ESA shall be monitored during the tests.

If not otherwise stated in this annex the test shall be performed according to IEC 61000-4-5.
2. ESA state during tests in configuration “REESS in charging mode coupled to the power grid”
 - 2.1. The ESA shall be in charging mode.
 - 2.1.2. Basic ESA conditions

The paragraph defines minimum test conditions (as far as applicable) and failures criteria for ESA immunity tests.

“REESS charging mode” ESA test conditions

Failure criteria

ESA shall be in configuration “REESS charging mode coupled to the power grid”.

incorrect charging condition (e.g. over-current, overvoltage)

The state of charge (SOC) of the traction battery shall be kept between 20 per cent and 80 per cent of the maximum SOC during the whole frequency range measurement (this may lead to split the measurement in different sub-bands with the need to discharge the vehicle’s traction battery before starting the next sub-bands).

If the test is not performed with a REESS the ESA should be tested at rated current. If the current consumption can be adjusted, then the current shall be set to at least 20 per cent of its nominal value.

- 2.2. Only non-perturbing equipment shall be used while monitoring the ESA. The ESA shall be monitored to determine whether the requirements of this Annex are met (e.g. by using (a) video camera(s), a microphone, etc.).

-
3. **Test equipments**
 - 3.1. The test equipments is composed of a reference ground plane (a shielded room is not required), a surge generator and a coupling / decoupling network (CDN).
 - 3.2. The surge generator shall meet the condition defined in paragraph 6.1 of *IEC 61000-4-5*.
 - 3.3. The coupling / decoupling network shall meet the condition defined in paragraph 6.3 of *IEC 61000-4-5*.
 4. **Test setup**
 - 4.1. The ESA test setup is based on the setup described in paragraph 7.2 of *IEC 61000-4-5*.
 - 4.2. The ESA shall be placed directly on the ground plane.
 - 4.3. The Technical Service shall perform the test as specified in paragraph 7.8.2.1.

Alternatively, if the manufacturer provides measurement from a test laboratory accredited to the applicable parts of *ISO 17025* and recognized by the Approval Authority, the Technical Service may choose not to perform the test to confirm that the ESA meets the requirements of this Annex.
 5. **Generation of required test level**
 - 5.1. **Test methodology**
 - 5.1.1. The test method according to *IEC 61000-4-5* shall be used to establish the test level requirements.
 - 5.1.2. **Test phase**

The ESA shall be positioned on the ground plane. The electrical surge shall be applied on the ESA on the AC/DC power lines between each line and earth and between lines by using CDN as described in Appendix 1, figure 1 to 4 of this annex.

The test set-up must be noted in the test report

Annex 22 – Appendix 1

ESA in configuration "REESS charging mode coupled to the power grid"

Figure 1

ESA in configuration "REESS charging mode coupled to the power grid" – Coupling between lines for DC or AC (single phase) power lines

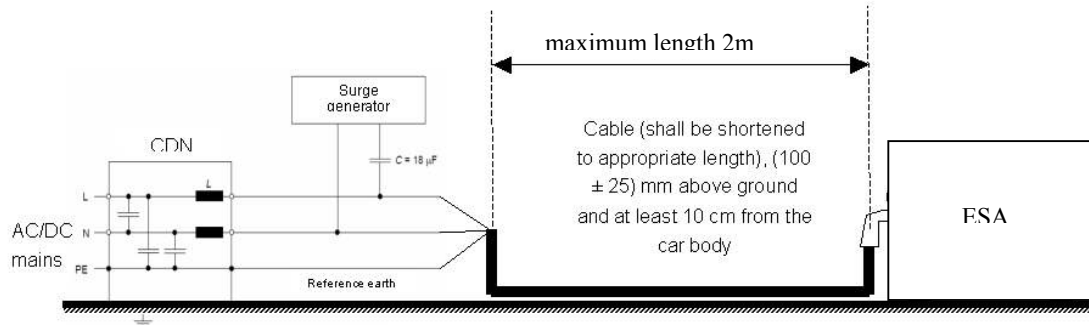

Figure 2

ESA in configuration "REESS charging mode coupled to the power grid" - Coupling between each line and earth for DC or AC (single phase) power lines

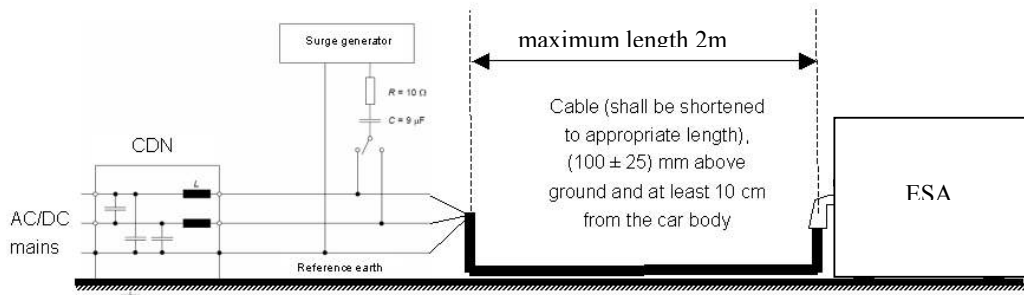

Figure 3

ESA in configuration “REESS charging mode coupled to the power grid” - Coupling between lines for AC (three phases) power lines

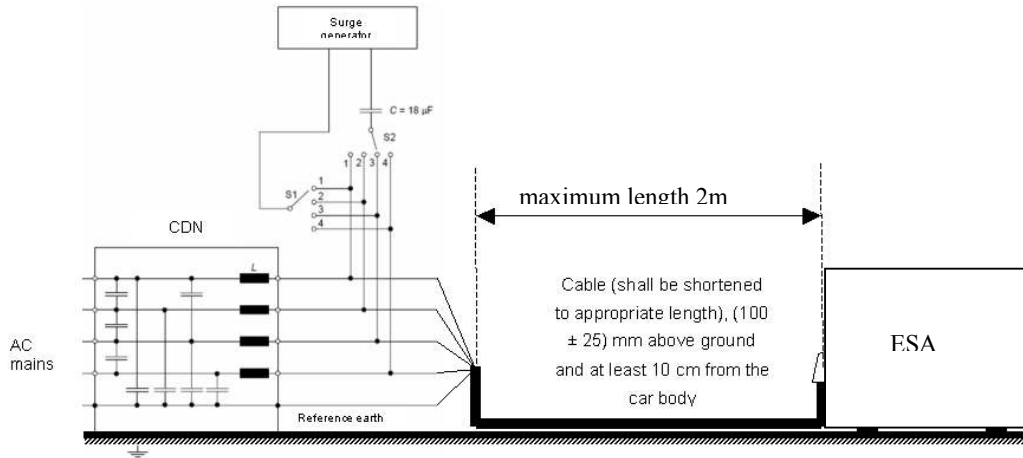
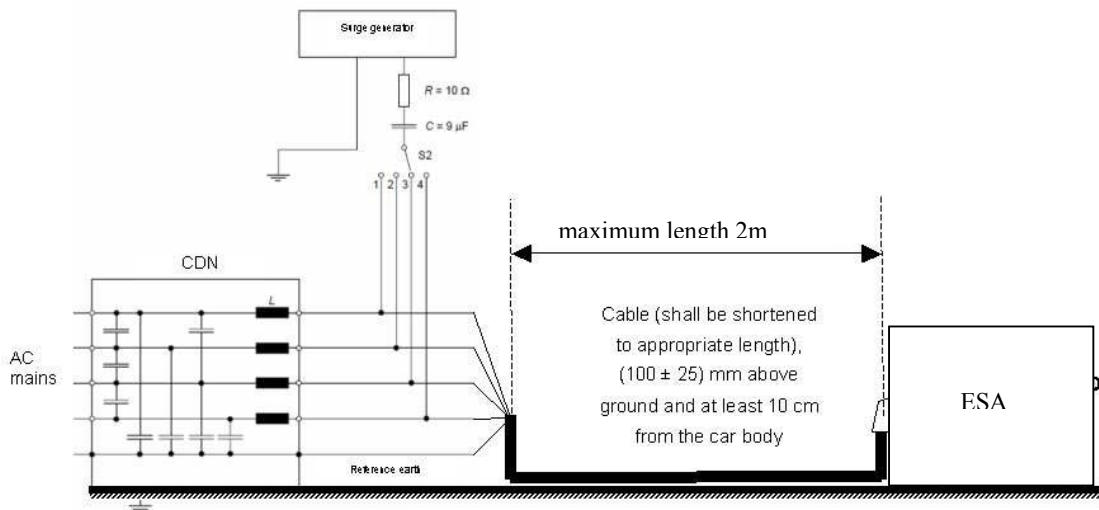

Figure 4

ESA in configuration “REESS charging mode coupled to the power grid” - Coupling between each line and earth for AC (three phases) power lines



II. Justification

1. The current legislation in the field of EMC for motor vehicles and their trailers is based on directive 72/245/EC as last amended by directive 2009/19/EC and R 10.03 is equivalent. The directive is one of the separate directives within the European vehicle type-approval system. While this directive applies to motor vehicles and their components, two further directives deal with questions of electromagnetic compatibility. The horizontal EMC Directive 89/336/EEC as last amended by 2004/108/EC covers almost all other electrical/electronic equipment. The Low Voltage Directive (LVD) 2006/95/EC applies also to on-board charger where product standards contain electrical safety requirements and EMC requirements.

2. On-board chargers are electronic automotive components which can be both:

- components which are incorporated in other electronic modules and which cannot be identified in a vehicle as a separate electronic component and
- “*Electrical/electronic sub-assemblies*” (ESAs) which can be described as separate electrical and/or electronic devices or set(s) of devices.

3. This proposal aims to adapt Regulation No.10 to the technical progress. The main objective is to extend the scope of the Regulation 10.04 to allow component base tests and approval for on-board chargers which are used for charging the REESS. Therefore, the following ESA tests have been added in accordance with the vehicle tests of 04 series of amendments to the UN Regulation No. 10.

- (a) Harmonic current and conducted emissions;
- (b) Voltage changes, voltage fluctuations and flicker in public low-voltage systems;
- (c) Electrical fast transients/burst;
- (d) Surges.

Additionally, the vehicle based tests for REESS charging systems have been updated to be in line with the current horizontal EMC Directive.

4. This amendment takes on-board Regulation No.10, EMC requirements for emission and immunity for on-board charger when the on-board charging system is connected to the mains for charging. Reference is made to CISPR or IEC relevant applicable standards, or equivalent relevant ISO standards (i.e. immunity).

5. The test provisions and certain reference limits take into account the work done in international harmonization community.

6. When establishing test procedures and methods of measurement, the regulation refers to the latest standards available of the International Special Committee on Radio Interference (CISPR), the International Electrotechnical Committee (IEC) and the International Organization for Standardization (ISO).

Main modifications in Version 5 vs. Version 4

7. Beside changes in wording, numbering of chapters, figures and tables, the following changes were made.

8. Important hints: Items, which were changed in the same way in several chapters, in this paper are generally mentioned only once.

Chapter 1.3

9. Additional requirements for vehicles and ESAs. New abbreviation “REESS” – rechargeable energy storage system.

Chapter 2.5 and 2.6

10. Version of referred standards completely moved to Appendix 1

Chapter 2.7

11. Wording regarding “electrical/electronic” system changed.

Chapter 2.12

12. Immunity related functions: Definitions when coupled to power grid added:

- (a) Vehicle test: by leading to unexpected vehicle motion;
- (b) ESA test: by leading to an incorrect charging condition (e. g. overcurrent, overvoltage)

Chapter 2.15 (new)

13. Definition of charging mode coupled to the power grid.

Chapter 3.2.1

14. Flowchart extended by ESA with REESS.

Chapter 4

15. REESS in charging mode, for vehicle and for ESA, included into approval procedure.

Chapter 7.1.1

16. ESA added.

Chapter 7.1.1.2

17. Specification for ESA in configuration “REESS charging mode coupled to the power grid” added.

Chapter 7.1.3 (new)

18. Charging cable, delivered by the manufacturer, included into vehicle test and stated, that charging cable shall be type approved as part of the vehicle.

Chapter 7.1.4 (new)

19. Definition of the different types of artificial networks used for the tests.

Chapter 7.6.2.1

20. Clearer definition of “telecommunications access” added (CISPR 22).

Chapter 7.9.2.1

21. Clearer definition of surge test method added.

Chapter 7.11 (new)

22. Emission of harmonics on AC power lines from ESAs

Chapter 7.12 (new)

23. Emission of voltages changes, voltage fluctuations and flicker on AC power lines from ESAs.

Chapter 7.13 (new)

24. Emission of radiofrequency conducted disturbances on AC or DC power lines from ESA.

Chapter 7.14 (new)

25. Emission of radiofrequency conducted disturbances on network and telecommunication access from ESA.

Chapter 7.15 (new)

26. Specifications concerning the immunity of ESAs to electrical fast transient/bursts disturbances conducted along AC and DC power lines.

Chapter 7.16 (new)

27. Immunity of ESAs to surge conducted along AC or DC power lines.

Chapter 7.17 (new)

28. Emission of transient conducted disturbances generated by ESAs on 12/24 V supply lines.

Chapter 7.18 (new)

29. Immunity of ESAs to electromagnetic radiation.

Chapter 7.19 (new)

30. Immunity of ESAs to transient disturbances conducted along 12/24 V supply lines.

Chapter 7.20.1 (new)

31. Exceptions for telecommunication lines, which are not included in a telecommunication network. It is worth noting that an example of vehicle configuration with telecommunication access is missing on this page but it appears in Annex 14. The communication between vehicle and a fixed Electric Vehicle Supply Equipment is a point to point connection and hence a signalling port as defined in IEC 61000-6-3 (no requirement). The vehicle has no direct connection to a telecommunication network (physical layer).

Chapter 7.20.4 (new)

32. Exception for ESAs, which use Power Line Transmission (PLT) on AC/DC power lines.

Chapter 7.20.5 (new)

33. Exceptions for vehicles which are connected to local / private DC-charging station without additional participants.

Chapter 8 / 8.2

34. Including “REESS charging mode” in the procedure for extension of type approval for ESA addition or substitution.

Chapter 9 / 9.1, 9.3, 9.3.1, 9.3.2, 9.3.3

35. Including “REESS charging mode” in procedure for conformity of production.

Chapter 10 / 10.1

36. Including “REESS charging mode” in definition for penalties.

Appendix 2

37. Vehicle broadband reference limits, 10 m: Link to chapter 7.2.2.1 added.

Appendix 3

38. Vehicle broadband reference limits, 3 m: Link to chapter 7.2.2.2 added.

Appendix 6

39. Electrical/electronic sub-assembly, broadband reference limits: Link to chapter 7.10.2.1 added.

Appendix 8 (new)

40. Definition of HV artificial network added.

Annex 1

41. Examples for approval marks, numbering changed to “5”.

Annex 2a

42. New items added:

70: Minimum R_{sce} value (see chapter 7.3).

71: Charging cable delivered with the vehicle: YES / NO

72: If charging cable delivered with the vehicle: Length [m], cross sectional area [mm²]

Annex 2b

43. New items added, only applicable for charging systems:

10. Charger: on board/ external I/:

11. Charging current: direct current/ alternating current (number of phases / frequency / I/:

12. Maximal nominal current (in each mode if necessary):.....

13. Nominal charging voltage:.....

14. Basic ESA interface functions: ex: L1/L2/L3/N/E/control pilot:.....

15. Minimum R_{sc}e value (see chapter 7.11):.....

Annex 4

44. “REESS charging mode coupled to the power grid”:

2.2 Definition of SOC of traction battery, current consumption and handling added.

2.3 Definition of test set-up and placing of charging station.

2.4 Definition of using artificial network.

2.5 Application of impedance stabilization for communication lines.

2.6 Placing of power charging / communication cable.

4.3 Tables 1 and 2 added to ensure correct adjustment of spectrum analyser- / receiver parameters.

Appendix 1: pictures of test setup added, pictures including keys updated and more detailed.

Annex 6

45. Vehicle in configuration “REESS charging mode coupled to the power grid”

2.2.1.2 Test condition for “REESS charging mode” added.

2.2.3 Description of test set-up added.

2.3 Definition of placing of charging station and wiring.

2.4 Definition of using artificial network.

2.5 Application of Impedance stabilisation for communication lines.

2.6 placing of power charging / communication cable and setup

Appendix 1: pictures of test set-up added, pictures including keys updated and more detailed.

Annex 7

46. Embedding ESAs involved in “REESS charging mode coupled to the power grid”.

Embedding on-board battery charging unit.

2.1 ESA in charging mode, definition of SOC and current consumption.

3.1 – 3.2.6 Detailed test arrangement for ESAs added.

4.4 Definition of placing the LV- and HV-harnesses

Appendix 1: pictures of test setup and detailed keys added.

Annex 9

47. 1.2. Embedding ESAs involved in “REESS charging mode coupled to the power grid”.

1.2.1. Restrict ESA-test to ISO 11452-2 and ISO 11452-4.

2.2 ESA in charging mode, definition of SOC and current consumption.

4.1.2.1 – 4.1.2.1.7 Detailed definitions of test setup for absorber chamber test added.

4.3.2.1 – 4.3.2.1.6 Detailed definitions of test setup for bulk current injection test added.

Appendix 3 and 4: pictures of test setup absorber chamber test and BCI-test including keys added.

Annex 11

48. 2.1 Definition of SOC of traction battery, current consumption and handling added.

Appendix 1: pictures of test setup added, pictures including keys updated and more detailed.

Annex 12

49. 2.1 Definition of SOC of traction battery, current consumption and handling added.

Appendix 1: pictures of test set-up added, pictures including keys updated and more detailed.

Annex 13

50. 2.1 Definition of SOC of traction battery, current consumption and handling added.

3.2 Definition of using artificial network.

Appendix 1: pictures of test setup added, pictures including keys updated and more detailed.

Annex 14

51. 2.1 Definition of SOC of traction battery, current consumption and handling added.

3.2 Definition of placement of impedance stabilization.

3.3 Alternative test set-up regarding CISPR22.

Appendix 1: pictures of test setup added, pictures including keys updated and more detailed.

Annex 15

52. “REESS charging mode coupled to the power grid”:

2.1.2 Definition of SOC of traction battery, current consumption and handling added.

Appendix 1: picture updated with more details.

Annex 16

53. 2.1.2 Definition of SOC of traction battery, current consumption and handling added.

Appendix 1: pictures updated with more details.

Annex 17 (complete new ESA test method defined)

54. Emission of harmonics generated on AC Power lines from an ESA.

Annex 18 (complete new ESA test method added)

55. Emission of voltage changes voltage fluctuations and flicker on AC power lines from an ESA.

Annex 19 (complete new ESA test method added)

56. Emission of radiofrequency conducted disturbances on AC or DC power lines from an ESA.

Annex 20 (complete new ESA test method added)

57. Emission of radiofrequency conducted disturbances on network and telecommunication access from an ESA.

Annex 21 (complete new ESA test method added)

58. Immunity of an ESA to electrical fast transient / burst disturbances conducted along AC and DC power lines.

Annex 22 (complete new ESA test method added)

59. Immunity of ESAs to surges conducted along AC and DC power lines.

Annex	Test	Method	Vehicle/ESA	R10-3	R10-4	R10-5	
4	Emission BB 3 m/10 m	CISPR 12	Vehicle	X	X	X	other than REESS and REESS charging mode
5	Emission NB	CISPR 12	Vehicle	X	X	X	other than REESS
6	Immunity	ISO 11451-2	Vehicle	X	X	X	other than REESS and REESS charging mode
7	Emission BB	CISPR 25	ESA	X	X	X	other than REESS and REESS charging mode
8	Emission NB	CISPR 25	ESA	X	X	X	other than REESS and REESS charging mode
9	Immunity	ISO 11452-2 (ALSE) ISO 11452-3 (TEM) 11452-4 (BCI) ISO 11452-5 (Stripline)	ESA	X	X	X	other than REESS and REESS charging mode
10	Transients	ISO 7637-2	ESA	X	X	X	-
11	Harmonics (AC-Powerline)	IEC 61000-3-2 IEC 61000-3-12	Vehicle	0	X	X	REESS charging mode
12	Voltage Changes, Fluctuations, Flicker (AC-Powerline)	IEC 61000-3-3 IEC 61000-3-11	Vehicle	0	X	X	REESS charging mode
13	Conducted Emission (AC and DC-	CISPR 16-2-1	Vehicle	0	X	X	REESS charging mode
14	Conducted Emission (Network and Telecommunication)	CISPR 22	Vehicle	0	X	X	REESS charging mode
15	Burst	IEC 61000-4-4	Vehicle	0	X	X	REESS charging mode
16	Surge	IEC 61000-4-5	Vehicle	0	X	X	REESS charging mode
17	Harmonics (AC-Powerline)	IEC 61000-3-2 IEC 61000-3-12	ESA	0	0	X	REESS charging mode
18	Voltage Changes, Fluctuations, Flicker (AC-Powerline)	IEC 61000-3-3 IEC 61000-3-11	ESA	0	0	X	REESS charging mode
19	Conducted Emission (AC and DC-	CISPR 16-2-1	ESA	0	0	X	REESS charging mode
20	Conducted Emission (Network and Telecommunication)	CISPR 22	ESA	0	0	X	REESS charging mode
21	Burst	IEC 61000-4-4	ESA	0	0	X	REESS charging mode
22	Surge	IEC 61000-4-5	ESA	0	0	X	REESS charging mode

Transitional Provisions, para. 13

60. Paragraph 13 now consists of the following main subparagraphs:

13.1 General

13.2 Transitional provisions applicable to 03 series of amendments

13.3 Transitional provisions applicable to 04 series of amendments

13.4 Transitional provisions applicable to 05 series of amendments

Requirements in subparagraph 13.1 are applicable for more than one series of amendment.

The Transitional Provisions of the 03 series of amendments of UN Regulation 10 were kept unchanged.

61. The amendments to the Transitional Provisions, as proposed by Supplement 2 to 04 series of amendments to the UN Regulation No. 10 (ECE/TRAN/WP.29/GRE/2012/13, submitted by an expert from Japan), were adopted with no changes by GRE at its sixty-seventh session, and are now on the agenda of the WP.29 session in November 2012. These Transitional Provisions are kept in this proposal.
