

**Economic and Social Council**Distr.: General
20 February 2014

Original: English

Economic Commission for Europe

Inland Transport Committee

World Forum for Harmonization of Vehicle Regulations**Working Party on General Safety Provisions****106th session**

Geneva, 5–9 May 2014

Item 2(a) of the provisional agenda

Regulation No. 107 (M₂ and M₃ vehicles) –**Proposals for further amendments****Proposal for amendments to Regulation No. 107 (M₂ and M₃ vehicles)****Submitted by the expert from Sweden ***

The text reproduced below was prepared by the expert from Sweden to introduce fire suppression systems for buses and coaches upon detection of fire in the engine and/or heater compartment. It is based on an updated document which supersedes informal document GRSG-105-08 (see report ECE/TRANS/WP.29/GRSG/84, para. 13). The modifications to the current text of UN Regulation No. 107 are marked in bold for new or strikethrough for deleted characters.

* In accordance with the programme of work of the Inland Transport Committee for 2012–2016 (ECE/TRANS/224, para. 94 and ECE/TRANS/2012/12, programme activity 02.4), the World Forum will develop, harmonize and update Regulations in order to enhance the performance of vehicles. The present document is submitted in conformity with that mandate.

I. Proposal

The list of Contents, insert a new annex, to read:

"13 Requirements for type approval of fire suppression systems"

Insert a new paragraph 2.2.3., to read:

"2.2.3. "Fire suppression system type" for the purpose of Type-Approval as a component means a category of systems which does not essentially differ in the following aspects:

- (a) fire suppression system manufacturer;
- (b) extinguishing agent;
- (c) type of discharge points used (e.g. type of nozzle, extinguishing agent generator or extinguishing agent discharge tube);
- (d) type of propellant gas."

Paragraph 2.3., amend to read:

"2.3. "Approval of a vehicle, ~~or~~ a separate technical unit **or a component**" means the approval of a vehicle type, ~~or~~ of a bodywork **or of a component** type as defined in paragraph 2.2. with regard to the constructional features specified in this Regulation;"

Paragraph 3.1., amend to read:

"3.1. The application for approval of:

- (a) A vehicle type or;
- (b) A separate technical unit type or;
- (c) A vehicle type fitted with bodywork type already approved as a separate technical unit **or**;
- (d) **A component type.**

with regard to its constructional features shall be submitted by the responsible manufacturer or by his duly accredited representative."

Insert a new paragraph 3.3.4., to read:

"3.3.4. Appendix 4: For a fire suppression system type."

Insert new paragraphs 3.4. to 3.4.2., to read:

"3.4. In case of application for approval of a type of vehicle, the manufacturer shall also provide the following documents:

3.4.1. A copy of the approval communication form (Annex 1, Part 2, Appendix 4) for the fire suppression system, if applicable, as a component which is installed according to paragraph 7.5.1.5. of Annex 3.

3.4.2. An analysis regarding the installation of the fire suppression system, (see Annex 3, item 7.5.1.5.4.2.)"

Paragraph 3.4. (former), renumber as paragraph 3.5. and amend to read:

- "3.5. A vehicle(s), ~~or~~ a bodywork(s) **or a fire suppression system(s)** representative of the type to be approved shall be submitted to the Technical Service responsible for conducting the Type Approval tests."

Paragraphs 4.1. to 4.4., amend to read:

- "4.1. If the vehicle, ~~or~~ bodywork **or fire suppression system** submitted for approval pursuant to this Regulation meets the requirements of paragraph 5., approval of that vehicle, ~~or~~ bodywork **or fire suppression system** type shall be granted.
- 4.2. An approval number shall be assigned to each ~~vehicle~~ type approved. Its first two digits (at present [06], corresponding to the [06] series of amendments) shall indicate the series of amendments incorporating the most recent major technical amendment made to the Regulation at the time of issue of the approval. The same Contracting Party shall not assign the same number to another vehicle, ~~or~~ bodywork **or fire suppression system** type within the meaning of paragraph 2.2.
- 4.3. Notice of approval or of extension of approval of a vehicle, ~~or~~ bodywork **or fire suppression system** type pursuant to this Regulation shall be communicated to the Contracting Parties to the Agreement applying this Regulation by means of a form conforming to the model in Annex 1, **Part 2** to this Regulation.
- 4.4. There shall be affixed, conspicuously and in a readily accessible place specified on the approval form, to every vehicle, ~~or~~ bodywork **or fire suppression system** conforming to a vehicle, ~~or~~ bodywork **or fire suppression system** type approved under this Regulation, an international approval mark consisting of: "

Paragraph 4.7., amend to read:

- "4.7. The approval mark shall be placed close to or on the vehicle or bodywork data plate affixed by the manufacturer.

The approval mark shall be affixed to the main part of the fire suppression system. The marking need not be visible when the system is installed in the vehicle."

Paragraph 5.1., amend to read:

- "5.1. All vehicles shall comply with the provisions set out in Annex 3 to this Regulation. Bodywork approved separately shall comply with Annex 10. The approval of a vehicle incorporating a bodywork approved in accordance with Annex 10 shall be completed in accordance with that annex. **Fire suppression systems shall comply with Annex 13.** "

Paragraphs 6.1. and 6.1.1., amend to read:

- "6.1. Every modification of the vehicle, ~~or~~ bodywork **or fire suppression system** type shall be notified to the Type Approval Authority which approved the ~~vehicle~~ type. That department may then either:
- 6.1.1. Consider that the modifications made are unlikely to have an appreciable adverse effect and that, in any case, the vehicle, ~~or~~ bodywork **or fire suppression system** still complies with the requirements; or"

Paragraph 6.3., amend to read:

"6.3. The Competent Authority issuing the extension of approval shall assign a series number for such an extension and inform thereof the other Contracting Parties to the 1958 Agreement applying this Regulation by means of a communication form conforming to the model in Annex 1, ~~Appendix~~ **Part 2** to this Regulation."

Paragraph 7.1., amend to read:

"7.1. Vehicles, ~~and~~ bodyworks **and fire suppression systems** approved to this Regulation shall be so manufactured as to conform to the type approved by meeting the requirements set forth in paragraph 5. above."

Paragraphs 8.1. to 8.2., amend to read:

"8.1. The approval granted in respect of a vehicle, ~~or~~ bodywork **or fire suppression system** type pursuant to this Regulation may be withdrawn if the requirement laid down in paragraph 5. above is not complied with.

8.2. If a Contracting Party to the Agreement applying this Regulation withdraws an approval it has previously granted, it shall forthwith notify the other Contracting Parties applying this Regulation, by means of a communication form conforming to the model in Annex 1, ~~Appendix~~ **Part 2** to this Regulation."

Paragraph 9., amend to read:

"9. Production definitely discontinued

If the holder of the approval completely ceases to manufacture a type of vehicle, ~~or~~ bodywork **or fire suppression system** under this Regulation, he shall so inform the authority which granted the approval. Upon receiving the relevant communication, that authority shall inform thereof the other Parties to the 1958 Agreement applying this Regulation by means of a communication form conforming to the model in Annex 1, ~~Part 2~~ **Part 2** to this Regulation."

Annex 1, Part 1, Appendix 1, insert new items 4.3. to 4.3.2. to read:

- 4.3. Fire suppression system**
- 4.3.1. Make and type of the fire suppression system:.....**
- 4.3.2. Type approval number of the fire suppression system:....."**

Annex 1, Part 1, Appendix 3, insert items 4. to 4.2. to read:

- 4. Fire suppression system**
- 4.1. Make and type of the fire suppression system:.....**
- 4.2. Type approval number of the fire suppression system:....."**

Annex 1, Part 1, insert new Appendix 4, to read:

"Annex 1

Part 1

Appendix 4

Model information document relation to Regulation No. 107 relating to Type Approval of a fire suppression system as a component

The following information, if applicable, shall be supplied in triplicate and include a list of contents. Any drawings shall be supplied in appropriate scale and in sufficient detail on size A4 or on a folder of A4 format. Photographs, if any, shall show sufficient detail.

If the components have electronic controls, information concerning their performance shall be supplied.

1. **General**
- 1.1. **Make (trade name of manufacturer):**
- 1.2. **Type and general commercial description:**
- 1.5. **Name and address of manufacturer:**

2. **Fire suppression system**
- 2.1. **Extinguishing agent (make and type):**
- 2.2. **Mass of extinguishing agent (needed in a 4 m³ engine compartment): ...**
- 2.3. **Type of discharge points (e.g. type):**
- 2.4. **Number of discharge points (needed in a 4 m³ engine compartment)¹: ...**
- 2.5. **Length of discharge tube (for 4m³ engine compartment)¹:**
- 2.6. **Type of propellant gas¹:**
- 2.7. **Pressure of propellant gas¹:**
- 2.8. **Minimum operating temperature:**
- 2.9. **Dimensions of pipes and fittings:**
- 2.10. **Detailed description, layout drawings and installation manual of the fire suppression system and its components:"**

Annex 1, Part 2, insert a new Appendix 4, to read:

"Annex 1

Part 2

Appendix 4

Communication

(Maximum format: A4 (210 x 297 mm))



issued by: Name of administration:
.....
.....
.....

concerning²: **APPROVAL GRANTED**
APPROVAL EXTENDED
APPROVAL REFUSED
APPROVAL WITHDRAWN
PRODUCTION DEFINITELY DISCONTINUED

of a type of a component with regard to Regulation No. 107

Approval No.: Extension No.:

Section I

1. **Make (trade name of manufacturer):**.....
2. **Type:**
3. **Means of identification of type if marked on the component:**
- 3.1. **Location of that marking:**
4. **Name and address of manufacturer:**
5. **If applicable, name and address of manufacturer's representative:**
5. **Location and method of affixing of the Type-Approval mark:**

Section II

1. **Additional information (where applicable): See addendum**
2. **Technical Service responsible for carrying out the tests:**
3. **Date of test report:**
4. **Number of test report:**
5. **Remarks (if any): See Addendum**
6. **Place:**

- 7. Date:
- 8. Signature:.....
- 9. The index to the information package lodged with the Approval Authority, which may be obtained on request, is attached.

**Addendum to Type-Approval certificate No.....
concerning the Type-Approval of a fire suppression system as a component
with regard to Regulation No. 107**

- 1. Additional information
- 1.1. Extinguishing agent (make and type):
- 1.2. Mass of extinguishing agent (needed in a 4 m³ engine compartment):
- 1.3. Type of discharge points (e.g. type of nozzles) ¹:
- 1.4. Number of discharge points (needed in a 4 m³ engine compartment) ¹:
- 1.5. Length of discharge tube (for a 4 m³ engine compartment) ¹:
- 1.6. Type of propellant gas ¹:
- 1.7. Pressure of propellant gas (needed in a 4 m³ engine compartment) ¹:
- 1.8. Minimum operating temperature:
- 1.9. Dimensions of pipes and fittings:"

Annex 2, add a new Model D, to read:

"Model D

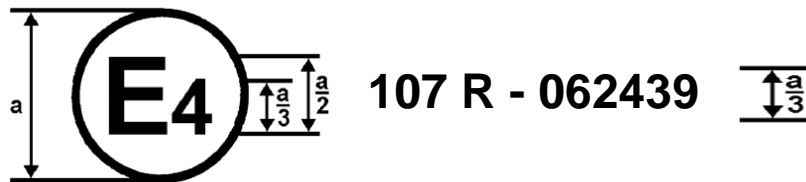

a = 8 mm min.

The above approval mark affixed to a fire suppression system shows that the fire suppression system type has been approved in the Netherlands (E4) as a component, pursuant to Regulation No. 107 under approval number 062439. The approval number indicates that the approval was granted according to the requirements of Regulation No. 107 as amended by the 06 series of amendments."

Annex 3, paragraphs 7.5.1.5. to 7.5.1.5.1., amend to read:

"7.5.1.5. Vehicles equipped with an internal combustion engine located in the rear of the driver's compartment, shall be equipped with a fire suppression system in the engine compartment and in each compartment where a combustion heater is located. The fire suppression system shall comply with the requirements in Annex 13.

The fire suppression system shall be equipped with an alarm system providing the driver with both an acoustic and a visual signal in the

event of excess temperature in the engine compartment and in each compartment where a combustion heater is located.

~~In the case of vehicles having the engine located to the rear of the driver's compartment, the compartment shall be equipped with an alarm system providing the driver with both an acoustic and a visual signal in the event of excess temperature in the engine compartment and in each compartment where a combustion heater is located.~~

- 7.5.1.5.1. **The suppression system shall be automatically activated through a fire detection system.** The **detection alarm** system shall be designed so as to detect a temperature in the engine compartment, and in each compartment where a combustion heater is located in excess of the temperature occurring during normal operation."

Annex 3, paragraph 7.5.1.5.3., amend to read:

- "7.5.1.5.3. The ~~alarm~~ **fire suppression** system shall be operational whenever the engine start device is operated, until such time as the engine stop device is operated, regardless of the vehicle's attitude."

Annex 3, insert new paragraphs 7.5.1.5.4. to 7.5.1.5.4.3., to read:

- "7.5.1.5.4. **The installation of the fire suppression system shall comply with the following requirements;**

- 7.5.1.5.4.1. **The fire suppression system shall be installed according to the system manufacturer's installation manual.**

- 7.5.1.5.4.2. **An analysis shall be conducted prior to the installation in order to determine the location and direction of suppression agent discharge points (e.g. nozzles, extinguishing agent generators or extinguishing agent discharge tube or other distribution points). Potential fire hazards within the engine compartment and each compartment where a combustion heater is located, shall be identified and discharge points located such that the suppression agent will be distributed to cover the fire hazard when the system activates. The spray pattern and direction of discharge points as well as the throwing distance shall be ensured to cover identified fire hazards. The system shall also be ensured to work properly regardless of the vehicle's altitude.**

Fire hazards to be taken into account in the analysis shall at least consist of the following: Components whose surface may reach temperatures above the auto-ignition temperature for fluids, gases or substances that are present within the compartment and electrical components and cables with a current or voltage high enough for an ignition to occur as well as hoses and containers with flammable liquid or gas (in particular if those are pressurized). The analysis shall be fully documented.

Maintenance instructions shall be part of the analysis.

- 7.5.1.5.4.3. **The suppression system shall be scaled from the tested system, based on the total gross volume of the engine and auxiliary heater compartments where the system is to be installed. When measuring the engine compartment and the auxiliary heater compartment, the gross volume of these compartments shall be measured, i.e. the volume of the engine and its components should not be subtracted.**

The scaling of the system includes the mass of the suppression agent, all discharge points and the mass of the propellant gas container. The system pressure shall remain the same as in the tested system. If the

system includes a discharge tube for the extinguishing agent, the length of the tube shall be scaled without nozzles. It is acceptable if the suppression system has more extinguishing agent and/or more discharge points and/or a longer discharge tube for the extinguishing agent and/or more propellant gas than required according to the scaling models found below.

If the gross volume of the engine and auxiliary heater compartments exceed 4 m³, the suppression system shall be scaled up using the following scaling factor calculated in (1) below. If the gross volume is less than 4 m³, it is allowed to scale down the suppression system using the scaling factor (2) below. S_x denotes the scaling factor and x denotes the total gross volume including the engine and auxiliary heater compartments [m³].

$$S_x = 0.1 \cdot x + 0.6 \quad (1)$$

$$S_x = 0.15 \cdot x + 0.4 \quad (2)$$

The down-scaled number of nozzles or other discharge points shall be rounded up if less than 8 discharge points are used during testing. Otherwise, the number may be rounded to the closest whole number."

Insert a new Annex 13, to read:

"Annex 13

Requirements regarding fire suppression systems

1. Specifications
 - 1.1. Fire suppression systems shall be tested for high fire load, low fire load, high fire load with fan and re-ignition.
 - 1.2. The test apparatus, test fires and general test conditions are described in Appendix 1 of this annex.
 - 1.3. High fire load
 - 1.3.1. The high fire load test shall be conducted in accordance with Appendix 2 of this annex.
 - 1.3.2. The test shall be conducted with the extinguishing agent and the propellant gas vessel cooled to the minimum operating temperature for the fire suppression system, as declared by the manufacturer.
 - 1.3.3. The fires shall be fully extinguished, either, in the minute after activation or upon end of the discharge of the suppression system.
 - 1.3.4. The test is considered passed either after success at first attempt or at two of three attempts in a case when first of these attempts fails.
 - 1.4. Low fire load
 - 1.4.1. The low fire load test shall be conducted in accordance with Appendix 3 of this annex.
 - 1.4.2. The fires shall be fully extinguished either in the minute after activation or upon end of the discharge of the suppression system.
 - 1.4.3. The test is considered passed if success was achieved at the first attempt or at two of three attempts in a case when first of these attempts fails.
 - 1.5. High fire load with fan

- 1.5.1. The high fire load test with fan shall be conducted in accordance with Appendix 4 of this annex.
- 1.5.2. The fires shall be fully extinguished either in the minute after activation or upon end of the discharge of the suppression system.
- 1.5.3. The test is considered passed if success was achieved at the first attempt or at two of three attempts in a case when first of these attempts fails.
- 1.6. Re-ignition test
 - 1.6.1. The re-ignition test shall be conducted in accordance with Appendix 5 of this annex.
 - 1.6.2. The fire shall be fully extinguished and no re-ignition shall occur 45 seconds after the extinguishing of the fire.
 - 1.6.3. The test is considered passed either if success was achieved at the first attempt or at two of three attempts in a case when first of these attempts fails.

Annex 13

Appendix 1

Test apparatus, test fires and general test specifications

- 1. Test apparatus
 - 1.1. The test apparatus is to be made of steel plate. The thickness of the steel plate shall be in accordance with Table 1. Figure 1 shows the test apparatus from the front side, Figure 2 from the rear side and Figure 3 from above. The front side of the test apparatus simulates the rear side of a real engine compartment.

Figure 1
Coordinate system for the position of objects in test apparatus (view from front side)

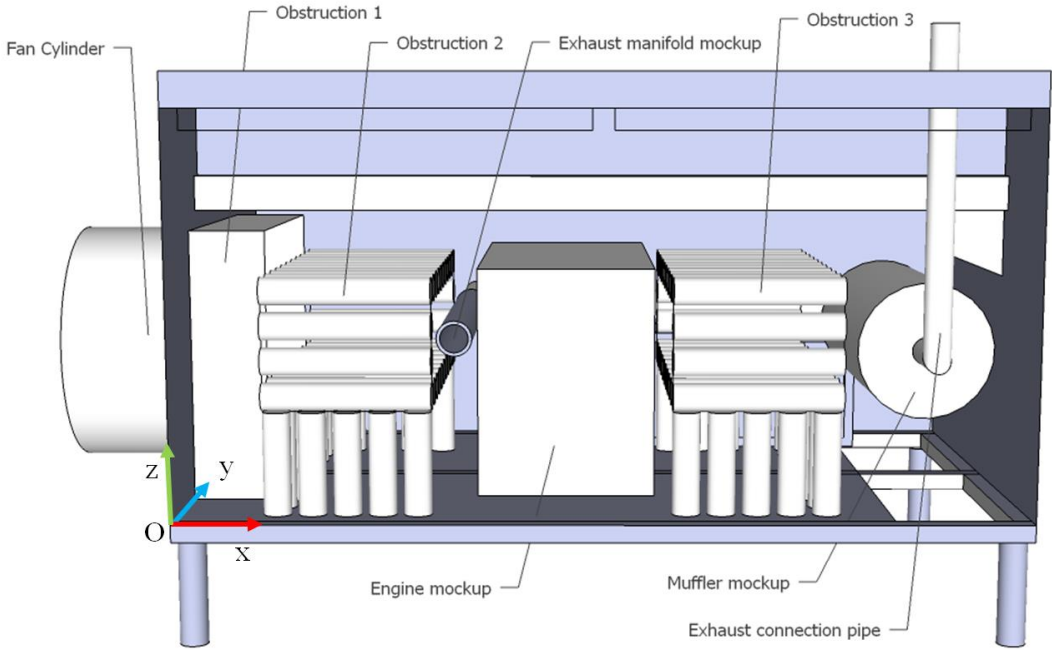

Figure 2
Test apparatus seen from the rear

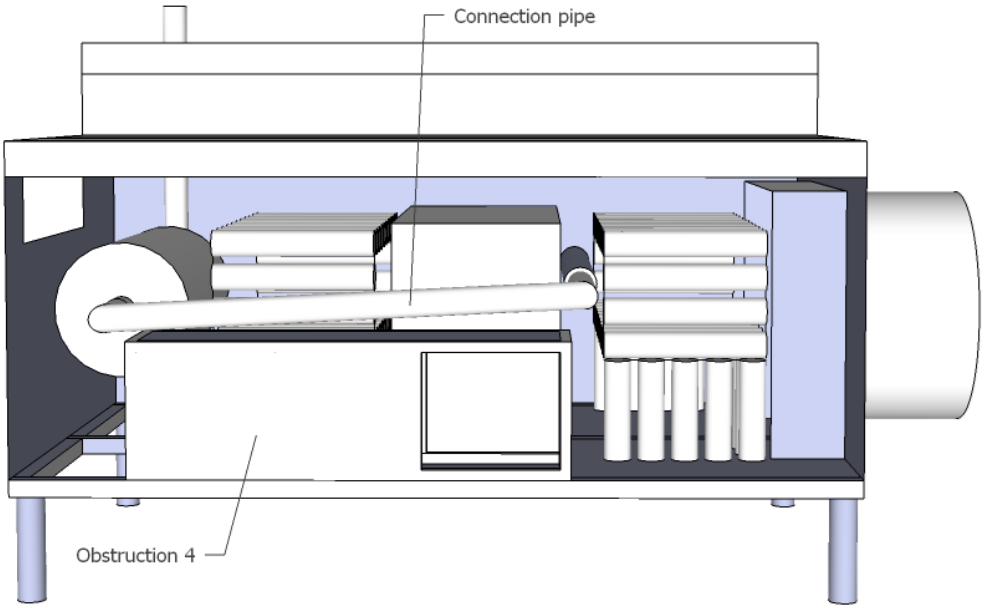

Figure 3
Test apparatus seen from above

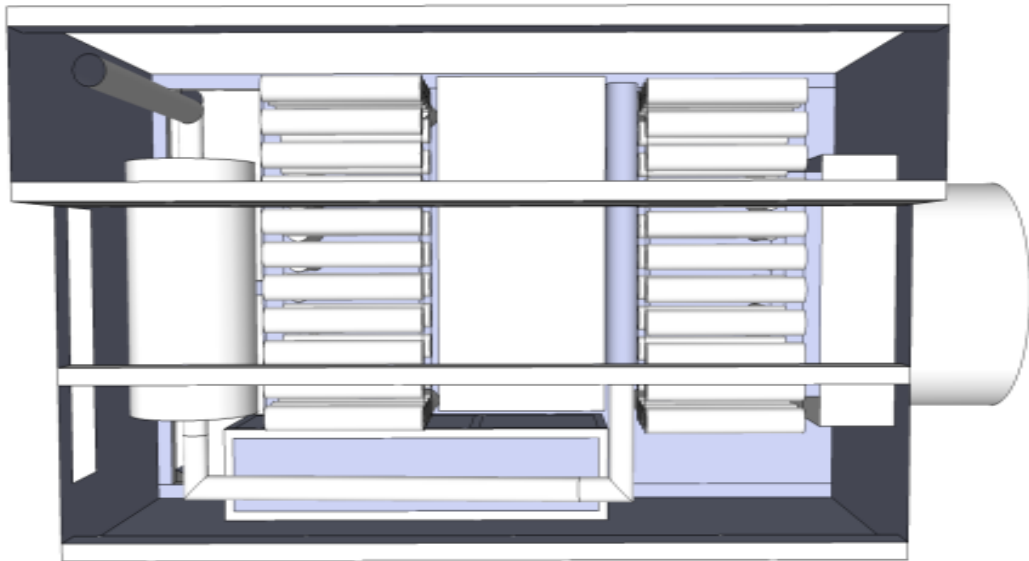

Table 1
Test apparatus objects

<i>Objects</i>	<i>Plate thickness</i>
Fan cylinder	1.5 – 2 mm
Obstructions	1.5 – 2 mm
Exhaust manifold mock-up	8 mm
Engine mock-up	2 – 3 mm
Muffler mock-up	2 – 3 mm
Exhaust pipe	2 – 3 mm
Connection pipe	2 – 3 mm
Walls, ceiling and floor	1.5 – 3 mm

1.2. Object locations

1.2.1. All objects in the test apparatus are positioned according to coordinates (x, y, z) as shown in Table 2. Origin is the position marked (O) in Figure 1. The value of the coordinates is the distance in meter from origin (see Figure 1, i.e. left-front-bottom corner).

1.4. Apertures

- 1.4.1. In addition to the opening for the fan, the test apparatus includes six apertures. The dimensions and positions of the apertures are given according to the coordinates in Table 3. The positions are given by referring to two diagonally opposite corners (all apertures are rectangular in shape). The apertures are shown in Figure 4.

Table 3
Coordinates of apertures in the test apparatus

<i>Aperture</i>	<i>Coordinates [x; y; z] – [x; y; z]</i>	<i>Area of aperture</i>
A1	[0.03; 0.00; 1.08] – [1.18; 0.00; 1.13]	0.06 m ²
A2	[1.22; 0.00; 1.08] – [2.37; 0.00; 1.13]	0.06 m ²
B	[2.40; 0.50; 0.70] – [2.40; 1.30; 0.90]	0.16 m ²
C	[0.85; 1.50; 0.03] – [1.24; 1.50; 0.36]	0.13 m ²
D1	[2.00; 0.05; 0.00] – [2.35; 0.73; 0.00]	0.27 m ²
D2	[2.00; 0.78; 0.00] – [2.35; 1.20; 0.00]	0.26 m ²
	Total area of aperture:	0.94 m²

1.5. Fan

- 1.5.1. An axial fan with a diameter of 710 mm shall be mounted on the left side of the fan cylinder. The diameter of the cylinder shall be equal to the diameter of the fan. The fan shall produce a certain rate of air flow through the cylinder according to the test scenarios in Appendix 2 to 5. A frequency converter may be used to adjust the fan speed.

1.6. Mock-up components

- 1.6.1. The dimensions of the engine mock-up are 1,000 mm × 650 mm × 500 mm. The dimensions of the muffler mock-up are Ø400 mm × 800 mm. The exhaust manifold mock-up shall have the inner dimensions of Ø80 mm × 900 mm. The mock-up components shall be hollowed. The exhaust manifold mock-up shall be connected to the muffler mock-up through a pipe with a diameter of 76 mm. A pipe from the muffler mock-up should also be used to carry the exhaust gases from the pre-warming system out from the test apparatus.

1.7. Thermocouples

- 1.7.1. Seven thermocouples (Tc) shall be mounted on the exhaust manifold mock-up, drilled 2 mm into the tube from the outside. Thermocouples Tc1 to Tc4 shall be located on top of the mock-up at the distances from the mock-up inlet according to Table 4. Thermocouples Tc5 to Tc7 shall be located around the mock-up at the same distance from the inlet as Tc2. The location of the thermocouples is illustrated in Figures 5 and 6.

Table 4
Distance to thermocouple from inlet of exhaust manifold mock-up

<i>Thermocouple</i>	<i>Distance from inlet</i>
Tc1	250 mm
Tc2	300 mm
Tc3	350 mm
Tc4	600 mm
Tc5	300 mm
Tc6	300 mm
Tc7	300 mm

Figure 5
Thermocouples on the exhaust manifold mock-up

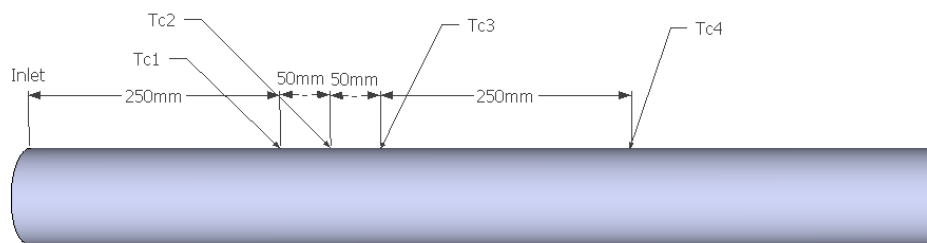
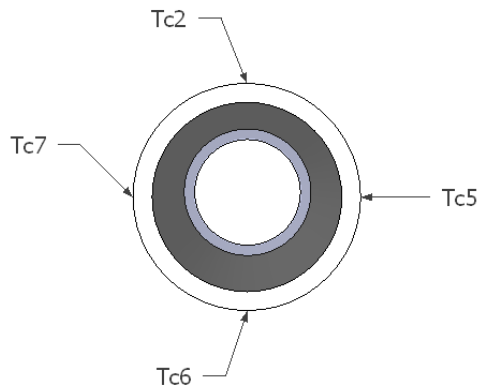

Figure 6
Thermocouples on the exhaust manifold mock-up (the inlet of the mock-up is on the left side)



1.8. Propane burner

1.8.1. The propane burner used to pre-warm the exhaust system shall be chosen as to fulfil the requirements on achieved temperatures specified in paragraph 3.4.6.

1.9. Obstructions

1.9.1. Obstruction 1 has the dimensions of 900 mm × 840 mm × 230 mm, as shown in Figure 7. Obstructions 2 and 3 consist of horizontal and

vertical obstruction tubes as shown in Figure 8. The horizontal obstruction tubes are closed and hollow, with a diameter of 80 mm and a length of 480 mm. The vertical tubes are hollow and open in the bottom, with a diameter of 80 mm and a length of 230 mm. The open distance between every tube is 20 mm. Obstruction 4 is a box measuring 1,250 mm × 300 mm × 390 mm as shown in Figure 9.

Figure 7
Obstruction 1

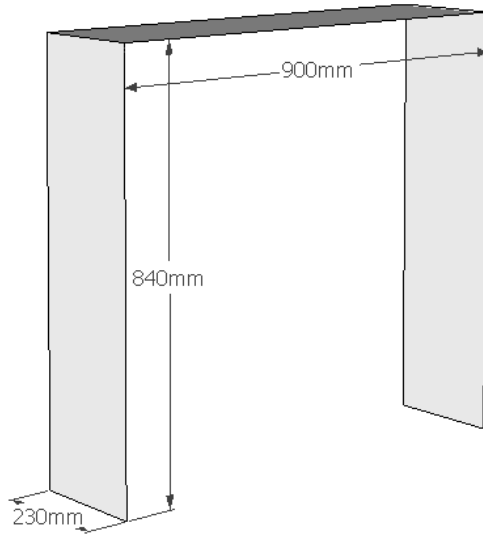

Figure 8
Obstruction 2 and 3

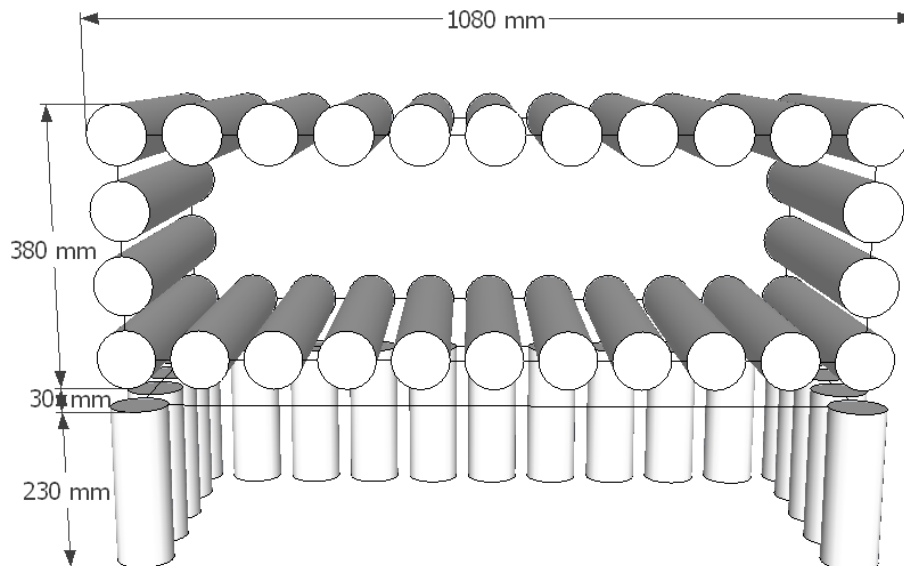
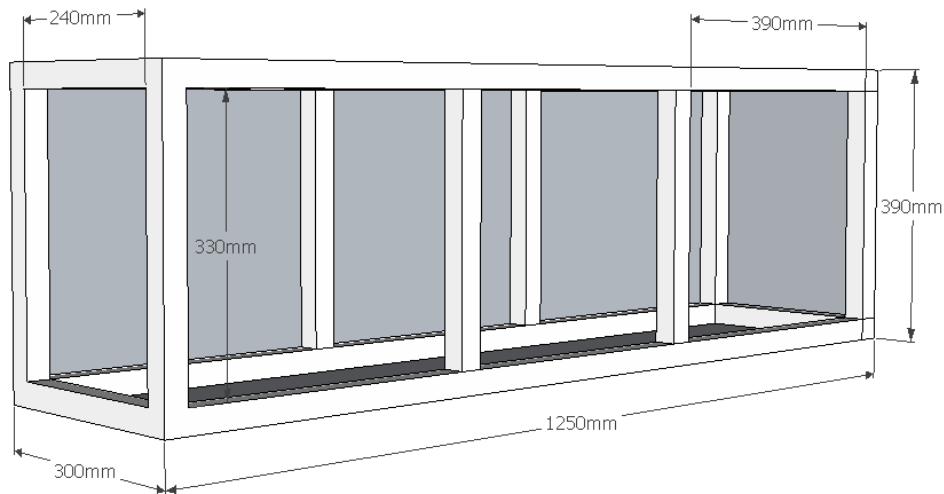

Figure 9
Obstruction 4



1.10. Pool Fire trays

- 1.10.1.** The square pool fire trays with fibreboards and the rectangular pool fire trays shall be positioned in its orientation according to the test scenarios in Appendices 2 to 4. Figure 10 shows the dimensions for test fire #2. The test fire shall be positioned perpendicular to the long edge of the test apparatus.

Figure 10
Distances for test fire #2

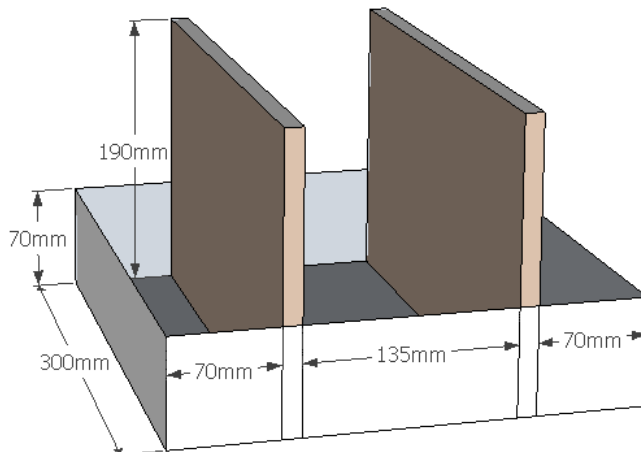

2. Test fires

- 2.1.** The test fires in Table 5 are to be used in the different test scenarios described in Appendices 2 to 5. Diesel oil (commercial fuel oil or light diesel oil), heptane (C_7H_{16}) and engine oil 15W-40 with a flash point

COC of 230 °C and viscosity at 40 °C of 107 mm²/s shall be used as test fuels.

Table 5
Test fires

<i>Test fire</i>	<i>Description</i>	<i>Fuel</i>	<i>Approximate peak Heat Release Rate 60 sec after ignition</i>
#1	Pool fire 300 mm × 300 mm	Diesel oil and heptane	60 kW
#2	Pool fire 300 mm × 300 mm and 2 fibreboards	Diesel oil and heptane	110 kW
#3	Pool fire 200 mm × 300 mm	Diesel oil and heptane	40 kW
#4	Pool fire Ø 150 mm	Diesel oil and heptane	7 kW
#5	Spray fire (450 kPa, 0.73 kg/min ±10%)	Diesel oil	520 kW
#6	Spray fire (450 kPa, 0.19 kg/min ±10%)	Diesel oil	140 kW
#7	Dripping oil fire (40 droplets/min ±10)	Engine oil	5 kW

2.2. Three different types of pool fire trays are applied in Table 5: square, rectangular and circular. Detailed descriptions of these trays are given in Table 6.

Table 6
Specification of pool fire trays

<i>Dimensions</i>	<i>Rim height</i>	<i>Nominal thickness</i>	<i>Used for test fire</i>
300 mm × 300 mm	70 mm	1.5 mm	#1, #2
200 mm × 300 mm	70 mm	2 mm	#3
Ø 150 mm	100 mm	1.5 mm	#4

2.3. The amount of water, diesel and heptane used in the tests should be in accordance with Table 7.

Table 7
Amount of fuel used in pool fire trays

<i>Dimensions</i>	<i>Water</i>	<i>Diesel</i>	<i>Heptane</i>	<i>Used for test fire</i>
300 mm × 300 mm	1.01	0.51	0.21	#1, #2,
200 mm × 300 mm	0.51	0.51	0.21	#3
Ø 150 mm	0.21	0.21	0.11	#4

- 2.4. Test fire #2 consists of a heptane pool and two diesel soaked fibreboards with a dry density of 3.5 kg/m^3 . The dimensions of the fibreboards shall be $12 \text{ mm} \times 295 \text{ mm} \times 190 \text{ mm}$. The fibreboards shall consist of at least 90 per cent raw material from wood. The moisture content in the boards before they are soaked in diesel oil shall not exceed 7 per cent. The fibreboards shall be completely immersed in diesel oil for at least 10 minutes prior to the test and mounted vertically in the pool fire tray not more than 10 minutes before the start of the test.
- 2.5. Test fire #5 and #6 consist of diesel oil spray fires while Test fire #7 consists of a dripping oil fire (by hot surface ignition).
- The spray nozzle for test fire #5 shall be a Lechler 460.368.30 or an equivalent. The spray nozzle for test fire #6 shall be a Lechler 212.245.11 or an equivalent. The spray nozzle for test fire #7 shall be a Danfoss 0.60X80H or an equivalent.
3. Installation of fire suppression system
- 3.1. To obtain the minimum discharge rate condition, an extinguishing system is to be assembled using its maximum piping limitations with respect to the number of fittings and size and length of pipe. The cylinder is to be used with its rated capacity and the cylinder or gas cartridge pressurized with propellant gas to the normal operating pressure.
- 3.2. The fire suppression system shall be installed by the system manufacturer or supplier. Figure 11 shows the area where extinguishing agent discharge points such as of nozzles, extinguishing agent generators or extinguishing agent discharge tubes may be located. The discharge points shall be positioned inside the test apparatus, at two different areas:
- (a) In the ceiling and at the rear wall. Discharge points positioned in the ceiling must be positioned at a minimum of 750 mm above the floor level ($z \geq 0.75$) and outside of Obstruction 1. Nozzles positioned at the rear wall shall be positioned within 350 mm from the rear wall ($y \geq 1.15$) and minimum 450 mm from the floor level ($z \geq 0.45$). Figures 17 and 18 show the area where the nozzles may be located.
- (b) Inside the small box (referred to as Obstruction 4) in the rear side of the test apparatus. Nozzles should be located in the ceiling of the box with a minimum of 290 mm from the floor ($z \geq 0.29$).

Figure 11

Nozzle positioning seen from the rear side of test apparatus

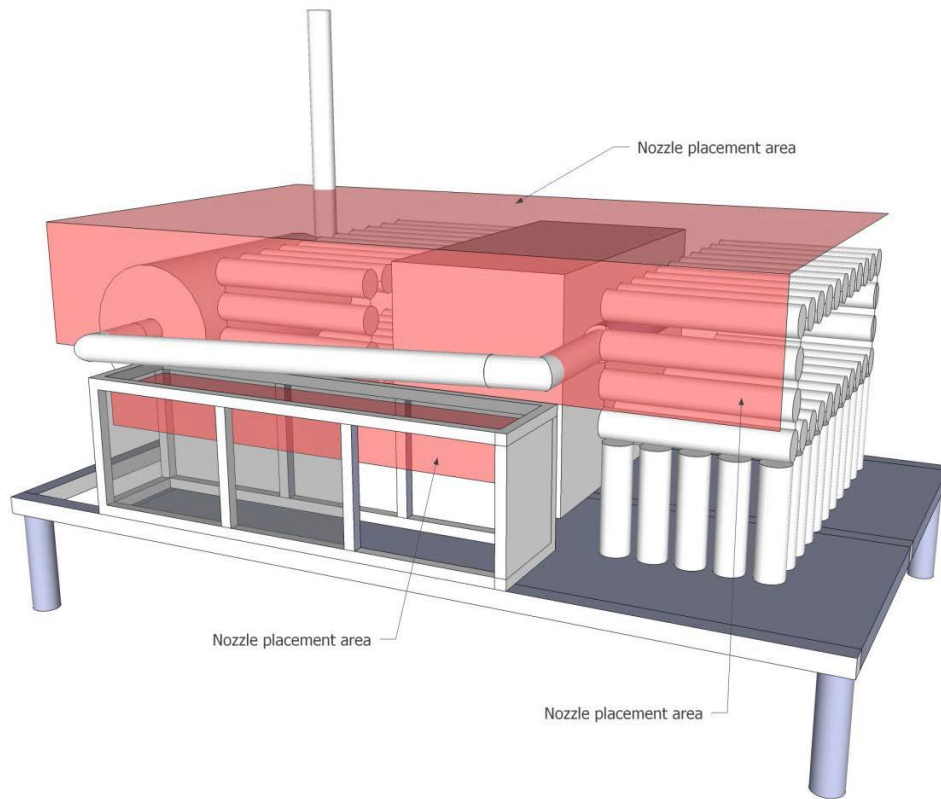

- 3.3. The system set-up and configuration shall be observed and documented prior to the test (e.g. amount of suppression agent and propellant gas, system pressure, number, type and location of discharge points, length of pipes and number of fittings).

Temperature shall be measured during the re-ignition tests at locations specified in Appendix 1.

- 3.4. Practical conduct of a test

- 3.4.1. The pool fire trays are to be filled with diesel and heptane on a base of water according to Table 7. If fibreboards are to be used as a fire source, the fibreboards shall be soaked in diesel oil, prior to the test, according to instructions in paragraph 2.4.

- 3.4.2. A pre-burn time based on the information in Appendix 2 to 5 is required. The pre-burn time is measured beginning from the time the first fire is ignited. All pool fires in the test scenarios shall be ignited within the allowed ignition-time, according to Appendix 2 to 5, using a suitable ignition source. The low fire load scenario in Appendix 3 may be performed either with one test fire at a time or the test fires combined with the suppression system showing its ability to extinguish all test fires, separately or merged.

- 3.4.3. A fan is used in some of the test scenarios to obtain a specific air flow rate into the test apparatus. The fan shall be engaged 30 seconds before the suppression system is activated. The fan shall remain active until the

test is complete, i.e. until it is determined whether the test is passed or failed.

- 3.4.4. A diesel spray is used in some of the test scenarios. The diesel spray shall be activated 10 seconds prior to activation of the suppression system. The diesel spray shall remain active until the test is completed, i.e. until it is clarified if the test is passed or failed.
- 3.4.5. After the stipulated pre-burn time, the suppression system shall be manually or automatically activated.
- 3.4.6. In test for re-ignition, the exhaust manifold mock-up tube is pre-heated prior to the test with a burner. Pressurized air may be added to the flame for better combustion. The tube shall be heated from the inner side until the temperature of Tc2 is above 600 °C and Tc1 is above 570 °C and the temperatures of Tc5, Tc6 and Tc7 not are less than 520 °C. When the predefined temperatures are reached the pre-heating procedure stops. After 30 seconds the engine oil start dripping and the suppression system activates 15 seconds later. The engine oil shall ignite before activation of the suppression system. The oil should continue to drip on to the tube until it is clarified if the test is passed or failed.
4. Tolerances
- 4.1. A tolerance of ± 5 per cent of the stipulated values shall apply (for time values: ± 5 seconds).

Appendix 2

High fire load scenario

Table 1
Test fires in high fire load scenario

<i>Test fire</i> (see Table 5 in Appendix 1)	<i>Description</i>	<i>Coordinates [x; y; z]</i> (see Figure 1 in Appendix 1)
#6	Spray fire (4.5 bar, 0.19 kg/min)	[1.47; 0.73; 0.46]
#3	Pool fire 200 mm × 300 mm	[0.97; 0.85; 0.70]
#4	Pool fire Ø 150 mm	[0.97; 1.28; 0.00]
#3	Pool fire 200 mm × 300 mm	[1.54; 0.57; 0.36]
#2	Pool fire 300 mm × 300 mm and 2 Fibreboards	[1.54; 0.77; 0.36]
#3	Pool fire 200 mm × 300 mm	[1.54; 0.13; 0.00]

Note: The fan is not used

Table 2
Test procedure for high fire load scenario

<i>Time</i>	<i>Action</i>
00:00	Start measuring time
01:20	Ignite pool fires (within 20 seconds)

01:50	Start diesel spray
02:00	Activate suppression system

Figure 1
Test fire positioning, view from the front side

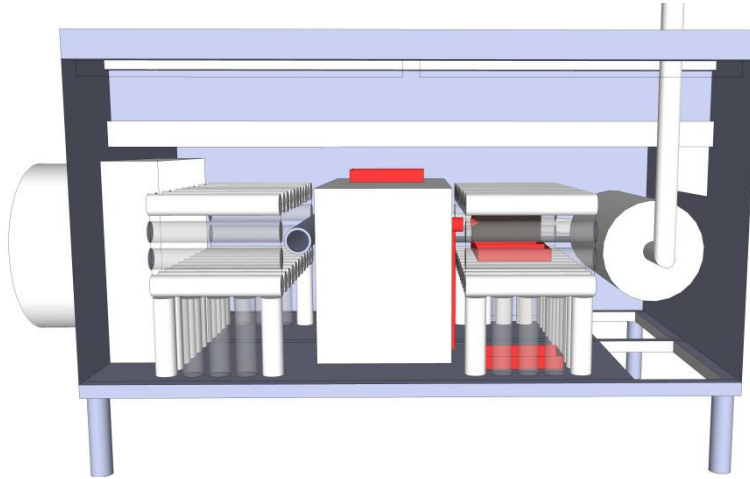
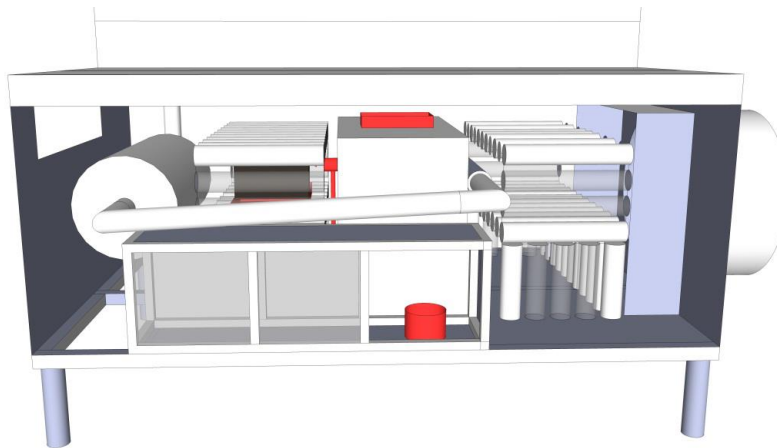

Figure 2
Test fire positioning, view from the rear side



Appendix 3

Low fire load scenario

Table 1
Test fires in low fire load scenario

<i>Test fire</i> (see Table 5 in Appendix 1)	<i>Description</i>	<i>Coordinates [x; y; z]</i> (see Figure 1 in Appendix 1)
#4	Pool fire Ø 150 mm	[0.02; 0.08; 0.00]
#3	Pool fire 200 mm × 300 mm	[0.37; 0.57; 0.00]
#4	Pool fire Ø 150 mm	[0.45; 1.20; 0.00]
#4	Pool fire Ø 150 mm	[0.97; 1.28; 0.00]
#4	Pool fire Ø 150 mm	[1.54; 0.57; 0.00]

Note: The fan is producing an air flow of 1.5 m³/s.

Table 2
Test procedure for low fire load scenario

<i>Time</i>	<i>Action</i>
00:00	Start measuring time
01:00	Ignite pool fires (within 30 seconds)
01:30	Engage the fan
02:00	Activate suppression system

Figure 1
Test fire positioning, view from the front side

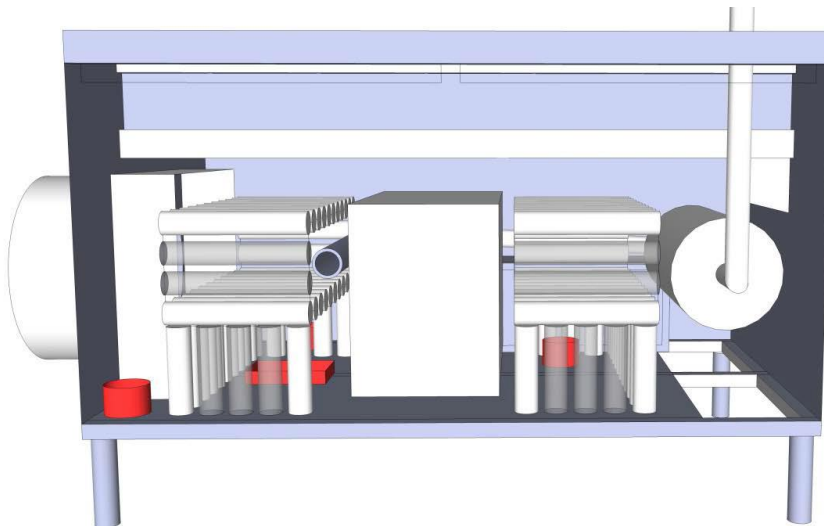
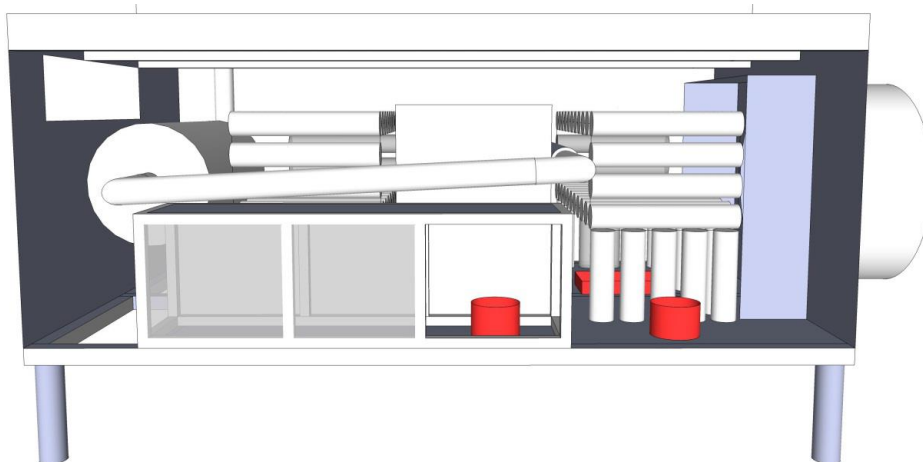

Figure 2
Test fire positioning, view from the rear side



Appendix 4
High fire load scenario with fan

Table 1
Test fires in high fire load scenario with fan

<i>Test fire</i> <i>(see Table 5 in appendix 1)</i>	<i>Description</i>	<i>Coordinates [x; y; z]</i> <i>(see Figure 1 in Appendix 1)</i>
#5	Spray fire (4.5 bar, 0.73 kg/min)	[0.37; 0.70; 0.46]
#1	Pool fire 300 mm × 300 mm	[0.37; 0.47; 0.36]
#2	Pool fire 300 mm × 300 mm and 2 fibreboards	[0.37; 0.77; 0.36]
#1	Pool fire 300 mm × 300 mm	[0.37; 0.13; 0.00]
#1	Pool fire 300 mm × 300 mm	[1.54; 0.13; 0.00]

Note: The fan is producing an air flow of 1.5 m³/s.

Table 2
Test procedure for high fire load scenario with fan

<i>Time</i>	<i>Action</i>
00:00	Start measuring time
01:00	Ignite pool fires (within 20 seconds)
01:30	Engage the fan
01:50	Start diesel spray
02:00	Activate suppression system

Figure 1
Test fire positioning, view from the front side

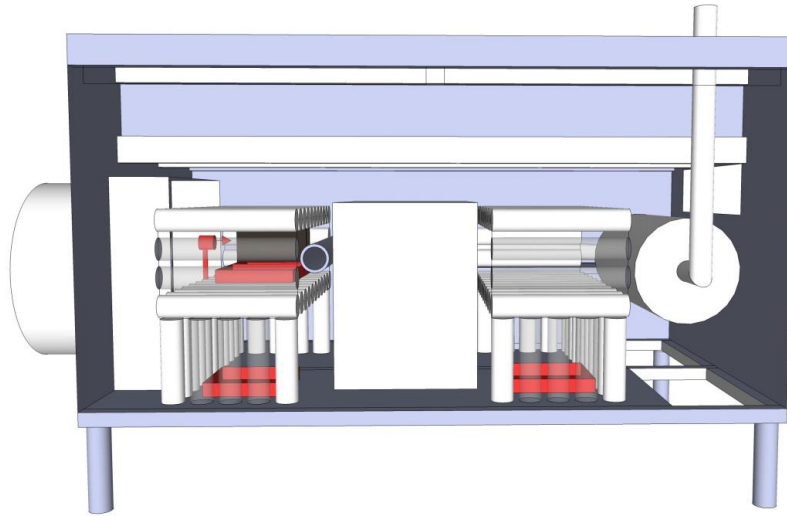

Appendix 5

Re-ignition scenario

Table 1
Test fires in re-ignition scenario

<i>Test fire</i> (see Table 5 in appendix 1)	<i>Description</i>	<i>Coordinates [x; y; z]</i> (see Figure 1 in Appendix 1)
#7	Dripping oil fire (2 bar, 0.01 kg/min)	[0.82; 0.28; 1.22]

Note: The fan is not used.

Table 2
Test procedure for re-ignition scenario

<i>Time</i>	<i>Action</i>
Prior to test	Pre-heat tube
00:00	Predefined temperatures are reached
00:30	Start oil dripping
00:45	Activate suppression system (the oil shall ignite before)

Figure 1
Test fire positioning, view from the front side

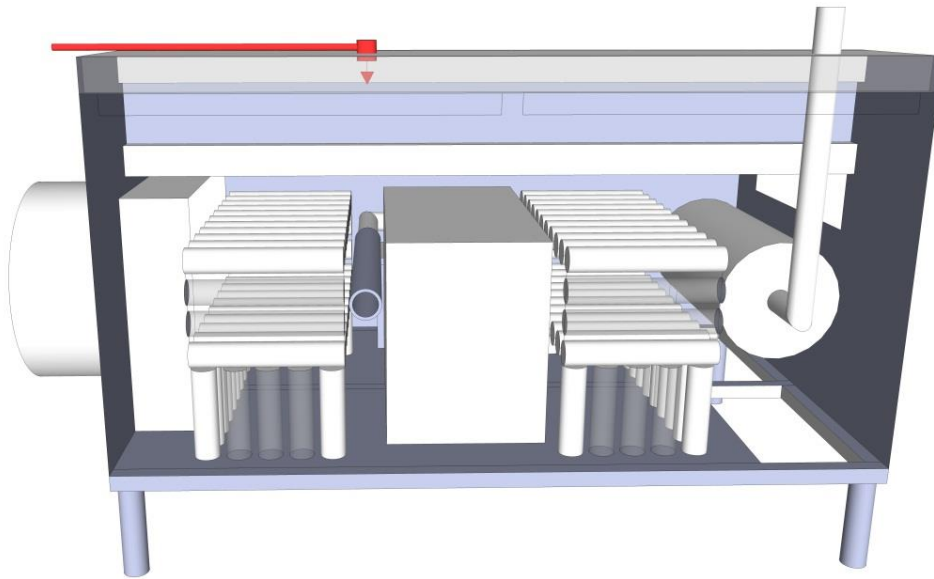

II. Justification

1. A few years ago Germany, France, Norway and Sweden agreed to combine their efforts to further develop the requirements that deal with fire safety in vehicles of categories M₂ and M₃ (see informal document GRSG-98-08).
2. Requirements have been introduced to decrease the number and consequences of bus fires in UN Regulation No. 107 (requirements regarding fire detection in the engine compartment, separate heating compartment and separate compartments, e.g. toilets) and UN Regulation No. 118 (burning behaviour of materials used in the interior compartment, the engine compartment or any separate heating compartment). But one issue remains i.e. to introduce requirements on automatic fire suppression systems in engine compartments and separate heating compartments.
3. At the 105th session of the Working Party on General Safety (GRSG), Sweden submitted informal document GRSG-105-08 introducing requirements for fire suppression systems. Since that session, the proposal has been slightly adjusted and this document supersedes GRSG-105-08
4. The proposal in short:
 - (a) Annex 13 has been added with requirements for type approval of fire suppression systems. The system's ability to extinguish fires in the environment of an engine compartment shall be tested. Test equipment, test conditions and test scenarios are described to ensure that the test methods are repeatable and correspond to realistic fire scenarios. The tests include four different scenarios: high fire load, low fire load, high fire load with fan and re-ignition. The methods have been developed by SP Technical Research Institute of Sweden.
 - (b) A number of paragraphs and annexes are supplemented with the administrative provisions for type approval of fire suppression systems.

(c) In Annex 3 (requirements to be met by all vehicles), requirements have been inserted on the installation of fire suppression systems. Buses and coaches with an internal combustion engine located to the rear of the driver's compartments shall be equipped with a fire suppression system in the engine compartment and in each compartment where a combustion heater is located. The requirements for fire detection are adjusted to fit automatic fire suppression systems.

A. Statistical data

5. Statistics from the Swedish Bus and Coach Federation show that the fire department is called in approximately 0.85 per cent of all fires on Swedish buses. This is only the reported number of fires and it is likely to assume that the real number of fires, including smaller fires extinguished by the driver, is much higher.

6. In Germany, 350 to 400 bus fires are reported every year which corresponds to 0.4 per cent of the buses (PUBA, 2010) and in Finland bus fires have almost doubled over the last ten years (VTT, 2010).

Figure 1

Statistical survey of calls to a fire department in bus fires in Sweden

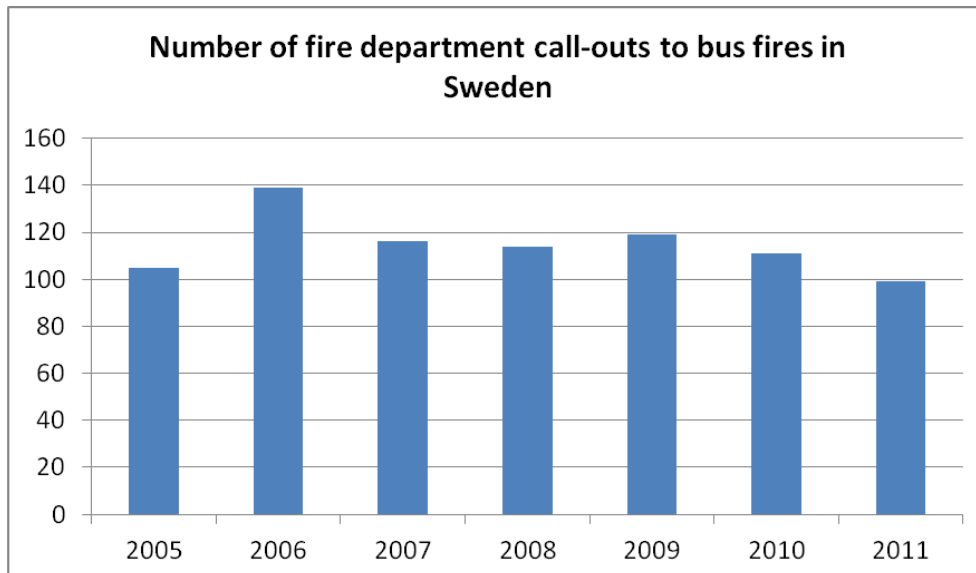

Source: The Swedish Bus and Coach Federation, 2012

7. Statistics show that a significant number of fires start in engine compartments or separate heating compartments. For example:

(a) In Finland, during 2010–2012, 103 out of 187 fires started in engine compartments or additional heater compartments. These fires had different causes (Trafic, 2013).

(b) In 2007, the New York State Public Transportation Safety Board (PTSB) conducted a review of the causes of previously investigated bus fires over a five year period (2002–2006). The review included 120 fire investigations and found that 76 per cent of the fires started in the engine compartment (PTSB, 2008).

(c) A study of fires in buses and coaches in Sweden, including data from bus fires where the fire department had been involved (years 2005, 2008 and 2011), reports that

the most common fire origin (location) is the engine compartment. (The Swedish Bus and Coach Federation, 2012).

8. The Swedish Accident Investigation Authority investigated a fire with two Compressed Natural Gas (CNG) propelled buses in urban traffic and strongly recommended mandatory fitting of fire suppression systems in engine compartments (Swedish Accident Investigation Authority, 2013).

9. By introducing harmonized requirements, it would be possible to reduce the consequences of a fire starting in the engine compartment. If the fire is extinguished or at least suppressed by an automatic system, the risk for passengers, drivers and other persons in the vicinity of the bus is reduced. The cost for the society should also decrease. Swedish insurance companies require a fire suppression system in the engine compartment of larger buses and coaches, otherwise they cannot be fire insured. This "requirement" was introduced for buses and coaches registered in 2004 and after. Since then the average cost per bus fire has decreased (see Figure 2).

Figure 2

Average cost per bus fire for insurance companies in Sweden

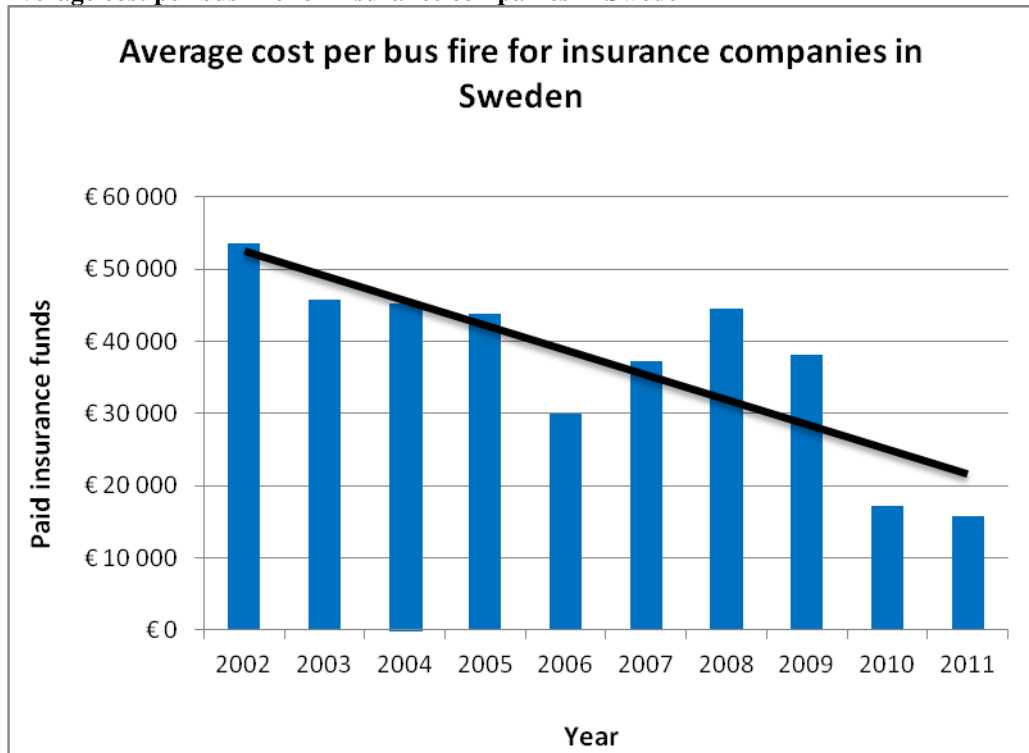

Source: Swedish Insurance companies, 2012

B Estimated costs

10. The estimated cost for building the engine mock-up is 12,000 to 17,000 €. It is a one-time cost for the technical service. The cost for testing a fire suppression system is expected to be maximum 17,000 €. An approved suppression system is estimated to cost around 1,100 € for each vehicle, installation excluded.

C. References:

New York State Public Transportation Safety Board (PTSB), *Special study bus fire analysis-PTSB investigations 2002 thru 2006*, (2008). Available from www.dot.ny.gov/divisions/operating/osss/ptsb-repository/Bus%20fire%20report%20FINAL%2008.pdf

Swedish Accident Investigation Authority, *Brand med två biogasbussar i stadstrafik i Helsingborg, Skåne län, den 14 februari 2012*. RO 2013:01, Statens haverikommission. (2013). Available from www.havkom.se/virtupload/reports/RO2013_01.pdf.

The Swedish Bus and Coach Federation, *Bussar och brandsäkerhet*, Svenska Bussbranschens Riksförbund, (2012). Available from www.transportgruppen.se/Global/BuA/Sveriges%20bussf%C3%B6retag%20bransch/Pdfer/brand_2012.pdf?epslanguage=sv

Trafi, *Bussipalot Suomessa 2010–2012*, Esa Kokki, Timo Loponen, (2013). Available from www.trafi.fi/filebank/a/1366109611/78a92ce787b1d2a28bc122c64710093c/12021-Trafin_julkaisu_10-2013_-_Bussipalot_2010-2012.pdf
