



Economic and Social Council

Distr.: General
5 September 2016

Original: English

Economic Commission for Europe

Inland Transport Committee

World Forum for Harmonization of Vehicle Regulations

170th session

Geneva, 15-18 November 2016

Item 8.4 of the provisional agenda

Other business:

**Consideration of proposals for
a new consolidated resolution**

Proposal for a draft Resolution on the common specification of light source categories (R.E.4)

Submitted by the Working Party on Lighting and Light-Signalling*

The text reproduced below was adopted by the Working Party on Lighting and Light-Signalling (GRE) at its seventy-fifth session (ECE/TRANS/WP.29/GRE/75, para. 8). It is based on ECE/TRANS/WP.29/GRE/2016/5 and Corr.1, as amended by Annex II to the report, and ECE/TRANS/WP.29/GRE/2016/6. It is submitted to the World Forum for Harmonization of Vehicle Regulations (WP.29) for consideration at its November 2016 session.

* In accordance with the programme of work of the Inland Transport Committee for 2016–2017 (ECE/TRANS/254, para. 159 and ECE/TRANS/2016/28/Add.1, cluster 3.1), the World Forum will develop, harmonize and update Regulations in order to enhance the performance of vehicles. The present document is submitted in conformity with that mandate.

Resolution [R.E.4] on the common specification of light source categories

Status table

This consolidated version of this Resolution contains all provisions and amendments adopted so far by the World Forum for Harmonization of Vehicle Regulations (WP.29) and is valid from the date as indicated in the following table until the date on which the next revision of this Resolution becomes valid:

| Version of the Resolution | Date * as from which the version is valid | Adopted by WP.29 | | Clarification |
|---------------------------|---|------------------|----------------------------|--|
| | | Session No. | Amendment document No. | |
| Original | [2017-xx-xx] | [170] | [ECE/TRANS/WP.29/2016/111] | Based upon Annexes 1 of Regulations: <ul style="list-style-type: none"> • No. 37, up to and including Supplement 44 • No. 99, up to and including Supplement 11 • No. 128, up to and including Supplement 5 |

* This date is the date of adoption of the amendment to the Resolution by WP.29 or the date of entering into force of an amendment to Regulation No. 37, 99 or 128 adopted by the Administrative Committee AC.1 as a package with the amendment to the Resolution in the same session of WP.29.

Contents

| | Page |
|--|------|
| Preamble | 3 |
| Introduction | 3 |
| 1. Scope | 4 |
| 2. Definitions..... | 4 |
| 3. Light source categories and their use | 5 |
| 3.1. Filament light sources..... | 5 |
| 3.2. Gas-discharge light sources | 10 |
| 3.3. LED light sources | 11 |
| Annexes | |
| 1. Sheets for filament light sources | 13 |
| 2. Sheets for gas-discharge light sources..... | 198 |
| 3. Sheets for LED light sources..... | 239 |

Preamble

1. The World Forum for Harmonization of Vehicle Regulations (WP.29),
2. DESIRING to harmonize technical requirements while ensuring high levels of safety, environmental protection, energy efficiency and anti-theft performance of wheeled vehicles, equipment and parts which can be fitted and/or be used on wheeled vehicles,
3. DESIRING to facilitate the trade of wheeled vehicles, equipment and parts with harmonized performance requirements among its participating countries,
4. BEARING IN MIND that the assessment of compliance with the technical prescriptions of Regulations concerning lighting and light signalling requires the specification of light sources in light source category sheets and/or information on which light source categories are applicable or excluded for use in particular lamps,
5. DESIRING to simplify the regulatory process for all stakeholders, while the technical specifications of the characteristics of light source categories and/or information on which light source categories are applicable or excluded for use in particular lamps, are subject of evaluation by the WP.29 Working Party on Lighting and Light-Signalling (GRE),
6. DECIDED that the specification of light sources in light source category sheets and/or the information which light source categories are applicable or excluded for use in particular lamps, are issued in a Resolution on the specification of light source categories.

Introduction

1. This Resolution finds its origin in the 1958 Agreement and its attached Regulations:
 - Regulation No. 37 "Filament lamps", up to and including Supplement No. 44;
 - Regulation No. 99 "Gas-discharge light sources", up to and including Supplement No. 11;
 - Regulation No. 128 "Light emitting diodes (LED) light sources", up to and including Supplement No. 5.
2. This Resolution is intended for reference from and approval of light sources according to:
 - Regulation No. 37 "Filament light sources";**
 - Regulation No. 99 "Gas-discharge light sources";
 - Regulation No. 128 "LED light sources".
3. This Resolution may also serve as a reference for other Regulations or standards.

** The title was harmonised with the other light source Regulations on the occasion of introduction of this Resolution.

1. Scope

This Resolution contains the specifications of light source categories and/or information on which light source categories are applicable or excluded for use in particular lamps.

In the case of "design to conform" requirements, reference should be made to values of characteristics of light sources of normal production, while values for standard (high accuracy) light sources may be ignored.

2. Definitions

2.1. General

2.1.1. "*Light source*" means one or more elements for visible radiation, with a base for mechanical and electrical connection, possibly assembled with one or more components to control the elements for visible radiation;

2.1.1.1. "*Filament light source*" means a light source where the only element for visible radiation is one or more filaments producing thermal radiation;

2.1.1.2. "*Gas-discharge light source*" means a light source where the only element for visible radiation is a discharge arc producing electroluminescence;

2.1.1.3. "*Light-emitting diode (LED) light source*" means a light source where the only element for visible radiation is one or more solid state junctions producing electroluminescence possibly completed with one or more elements for fluorescence-based conversion.

2.1.2. "*Standard (étalon) light source*" means a special light source used for the testing of lighting and light-signalling devices. It has reduced tolerances for dimensional, electrical and photometric characteristics as specified on the relevant data sheet.

2.1.3. "*Ballast*" means one or more components, either between supply and light source or integrated with a light source, to control the electrical current of the gas-discharge light source;

2.1.4. "*Objective value(s)*" means design value(s) to be achieved within specified tolerances when the light source or the ballast of the gas discharge light source is energized at specified test voltage(s)

2.2. Dimensional characteristics

2.2.1. "*Reference axis*" means an axis defined with reference to the cap and to which certain dimensions of the light source are referred.

2.2.2. "*Reference plane*" means a plane defined with reference to the cap and to which certain dimensions of the light source are referred.

2.2.3. "*Light centre*" means a point that represents the origin of the light emitted.

2.2.4. "*Light centre length*" means the distance between the reference plane and the light centre.

2.2.5. "*Viewing axis on to the light source*" means an axis through the nominal light centre at defined polar and azimuthal angle.

- 2.3. Electrical characteristics
- 2.3.1. "*Test voltage*" means the voltage, at the input terminals of the light source or at the terminals of the ballast for the gas-discharge light source, for which the electrical and photometric characteristics of the light source are intended and are to be tested.
- 2.3.2. "*Rated voltage*" means the voltage (in volts) marked on the light source or on the ballast.
- 2.3.3. "*Rated wattage*" means the wattage marked on the light source or on the ballast.
- 2.4. Photometric characteristics
- 2.4.1. "*Reference luminous flux*" means an accurately specified luminous flux value of a standard light source serving as a reference for the optical characteristics of a lighting or light signalling device.
- 2.4.2. "*Measuring luminous flux*" means specified value of the luminous flux for testing a filament light source with an internal shield to produce the cut-off.
- 2.4.3. "*Cumulative luminous flux*" means the luminous flux emitted by the light source under operating conditions, within a cone enclosing a specified solid angle and centred on the reference axis¹.
- 2.4.4. "*Normalized luminous intensity*" means luminous intensity divided by the luminous flux of the light source.

3. Light source categories and their use

3.1. Filament light sources

Characteristics* of categories of filament light sources as listed below are shown in Annex 1.

Luminous flux values in the light source category sheets concern white light unless otherwise specified in these sheets.

List of categories of filament light sources, grouped according to restrictions on use and their sheet numbers:

| <i>Group 1</i> | | | |
|--|-----------------|----------------|------------------------|
| <i>Filament light source categories (or types within these categories) without general restrictions:</i> | | | |
| | <i>Category</i> | <i>Note(s)</i> | <i>Sheet number(s)</i> |
| | H1 | *6 | H1/1 to 3 |
| | H3 | *6 | H3/1 to 4 |
| | H4 | | H4/1 to 5 |
| | H7 | | H7/1 to 4 |
| | H8 | | H8/1 to 4 |

¹ Based on term 17-267 from CIE standard *CIE S 017/E:2011: ILV: International Lighting Vocabulary*, online version [eILV](#)

| <i>Group 1</i> | | | | |
|--|-----------------|----------------|------------------------|--|
| <i>Filament light source categories (or types within these categories) without general restrictions:</i> | | | | |
| | <i>Category</i> | <i>Note(s)</i> | <i>Sheet number(s)</i> | |
| | H8B | | H8/1 to 4 | |
| | H9 | *3 | H9/1 to 4 | |
| | H9B | *3 | H9/1 to 4 | |
| | H10 | | H10/1 to 3 | |
| | H11 | | H11/1 to 4 | |
| | H11B | | H11/1 to 4 | |
| | H13 | | H13/1 to 4 | |
| | H15 | | H15/1 to 5 | |
| | H16 | | H16/1 to 4 | |
| | H16B | | H16/1 to 4 | |
| | H17 | | H17/1 to 6 | |
| | H18 | | H18/1 to 4 | |
| | H19 | | H19/1 to 5 | |
| | H20 | | H20/1 to 4 | |
| | H21W | *2 | H21W/1 to 2 | |
| | H27W/1 | | H27W/1 to 3 | |
| | H27W/2 | | H27W/1 to 3 | |
| | HB3 | | HB3/1 to 4 | |
| | HB4 | | HB4/1 to 4 | |
| | HIR2 | | HIR2/1 to 3 | |
| | HS1 | *6 | HS1/1 to 5 | |
| | HS5 | *5 | HS5/1 to 4 | |
| | PSX24W | *2 | P24W/1 to 3 | |
| | PSX26W | *2 | PSX26W1 to 3 | |
| | S2 | *5, *6 | S1/S2/1 to 2 | |

| <i>Group 2</i> | | | | |
|--|-----------------|----------------|------------------------|--|
| <i>Filament light source categories (or types within these categories) only for use in signalling lamps, cornering lamps, reversing lamps and rear registration plate lamps:</i> | | | | |
| | <i>Category</i> | <i>Note(s)</i> | <i>Sheet number(s)</i> | |
| | C5W | *6 | C5W/1 | |
| | H6W | | H6W/1 | |
| | H10W/1 | | H10W/1 to 2 | |
| | HY6W | | H6W/1 | |
| | HY10W | | H10W/1 to 2 | |
| | HY21W | | H21W/1 to 2 | |

| <i>Group 2</i> | | | |
|--|-----------------|----------------|---------------------------|
| <i>Filament light source categories (or types within these categories) only for use in signalling lamps, cornering lamps, reversing lamps and rear registration plate lamps:</i> | | | |
| | <i>Category</i> | <i>Note(s)</i> | <i>Sheet number(s)</i> |
| | P13W | | P13W/1 to 3 |
| | P21W | *6 | P21W/1 to 2 |
| | P21/4W | | P21/4W/1 (P21/5W/2 to 3) |
| | P21/5W | *6 | P21/5W/1 to 3 |
| | P27W | | P27W/1 to 2 |
| | P27/7W | | P27/7W/1 to 3 |
| | PR21W | | PR21W/1 (P21W/2) |
| | PR21/5W | | PR21/5W/1 (P21/5W/2 to 3) |
| | PS19W | | P19W/1 to 3 |
| | PS24W | | P24W/1 to 3 |
| | PSY19W | | P19W/1 to 3 |
| | PSY24W | | P24W/1 to 3 |
| | PW13W | | P13W/1 to 3 |
| | PW16W | | PC16W/1 to 3 |
| | PWR16W | | PC16W/1 to 3 |
| | PWY16W | | PC16W/1 to 3 |
| | PW19W | | P19W/1 to 3 |
| | PWR19W | | P19W/1 to 3 |
| | PWY19W | | P19W/1 to 3 |
| | PW24W | | P24W/1 to 3 |
| | PWR24W | | P24W/1 to 3 |
| | PWY24W | | P24W/1 to 3 |
| | PY21W | | PY21W/1 (P21W/2) |
| | PY21/5W | | PY21/5W/1 to 3 |
| | PY24W | | P24W/1 to 3 |
| | PY27/7W | | PY27/7W/1 (P27/7W/2 to 3) |
| | R5W | *6 | R5W/1 |
| | R10W | *6 | R10W/1 |
| | RR5W | | R5W/1 |
| | RR10W | | R10W/1 |
| | RY10W | *6 | R10W/1 |
| | T4W | *6 | T4W/1 |
| | W2.3W | | W2.3W/1 |
| | W3W | *6 | W3W/1 |
| | W5W | *6 | W5W/1 |
| | W10W | *6 | W10W/1 |

| <i>Group 2</i> | | | | |
|--|-----------------|----------------|------------------------|-----------------|
| <i>Filament light source categories (or types within these categories) only for use in signalling lamps, cornering lamps, reversing lamps and rear registration plate lamps:</i> | | | | |
| | <i>Category</i> | <i>Note(s)</i> | <i>Sheet number(s)</i> | |
| | W15/5W | | W15/5W/1 to 3 | |
| | W16W | | W16W/1 | |
| | W21W | | W21W/1 to 2 | |
| | W21/5W | | W21/5W/1 to 3 | |
| | WR5W | | W5W/1 | |
| | WR21/5W | | WR21/5W/1 | (W21/5W/2 to 3) |
| | WT21W | | WT21W/1 to 2 | |
| | WT21/7W | | WT21/7W/1 to 3 | |
| | WTY21W | | WT21W/1 to 2 | |
| | WTY21/7W | | WT21/7W/1 to 3 | |
| | WY5W | *6 | W5W/1 | |
| | WY10W | *6 | W10W/1 | |
| | WY16W | | W16W/1 | |
| | WY21W | | WY21W/1 to 2 | |

| <i>Group 3</i> | | | | |
|---|-----------------|----------------|------------------------|----------------------------|
| <i>Filament light source categories (or types within these categories) only for use in lamps as replacement parts for lamps on vehicles in use originally equipped with such lamps:</i> | | | | |
| | <i>Category</i> | <i>Note(s)</i> | <i>Sheet number(s)</i> | <i>From date onwards**</i> |
| | C5W | *7, *8 | C5W/1 | 26 July 2013 |
| | C21W | *8 | C21W/1 to 2 | 11 June 2008 |
| | H1 | *7 | H1/1 to 3 | 26 July 2013 |
| | H3 | *7 | H3/1 to 4 | 26 July 2013 |
| | H12 | | H12/1 to 3 | 15 July 2015 |
| | H13A | | H13/1 to 4 | 15 July 2015 |
| | H14 | | H14/1 to 4 | 26 July 2013 |
| | HB3A | | HB3/1 to 4 | 15 July 2018 |
| | HB4A | | HB4/1 to 4 | 15 July 2018 |
| | HIR1 | *3 | HIR1/1 to 3 | 15 July 2015 |
| | HS1 | *7 | HS1/1 to 5 | 26 July 2013 |
| | HS2 | *7 | HS2/1 to 3 | 26 July 2013 |
| | | *6 | | 1 September 2018 |
| | HS5A | *5 | HS5A/1 to 3 | 1 September 2018 |
| | HS6 | *4 | HS6/1 to 4 | 15 July 2018 |
| | P19W | *8 | P19W/1 to 3 | 28 October 2016 |

| <i>Group 3</i> | | | | |
|---|-----------------|----------------|--------------------------------|----------------------------|
| <i>Filament light source categories (or types within these categories) only for use in lamps as replacement parts for lamps on vehicles in use originally equipped with such lamps:</i> | | | | |
| | <i>Category</i> | <i>Note(s)</i> | <i>Sheet number(s)</i> | <i>From date onwards**</i> |
| | P21W | *7, *8 | P21W/1 to 2 | 26 July 2013 |
| | P21/5W | *7, *8 | P21/5W/1 to 3 | 26 July 2013 |
| | P24W | *8 | P24W/1 to 3 | 1 September 2018 |
| | PC16W | *8 | PC16W/1 to 3 | 28 October 2016 |
| | PCR16W | *8 | PC16W/1 to 3 | 28 October 2012 |
| | PCY16W | *8 | PC16W/1 to 3 | 28 October 2016 |
| | PR19W | *8 | P19W/1 to 3 | 28 October 2012 |
| | PR21/4W | *8 | PR21/4W/1 ; (P21/5W/2 to 3) | 15 July 2015 |
| | PR24W | *8 | P24W/1 to 3 | 28 October 2012 |
| | PR27/7W | *8 | PR27/7W/1 ; (P27/7W/2 to 3) | 15 July 2015 |
| | PSR19W | *8 | P19W/1 to 3 | 28 October 2012 |
| | PSR24W | *8 | P24W/1 to 3 | 28 October 2012 |
| | PX24W | *2 | P24W/1 to 3 | 1 September 2018 |
| | PY19W | *8 | P19W/1 to 3 | 28 October 2016 |
| | R2 | | R2/1 to 3 | 11 June 2008 |
| | R5W | *7, *8 | R5W/1 | 26 July 2013 |
| | R10W | *7, *8 | R10W/1 | 26 July 2013 |
| | RY10W | *7, *8 | R10W/1 | 26 July 2013 |
| | S1 | | S1/S2/1 to 2 | 11 June 2008 |
| | S2 | *7 | S1/S2/1 to 2 | 26 July 2013 |
| | S3 | | S3/1 | 26 July 2013 |
| | T1.4W | *8 | T1.4W/1 | 15 July 2015 |
| | T4W | *7, *8 | T4W/1 | 26 July 2013 |
| | W3W | *7, *8 | W3W/1 | 26 July 2013 |
| | W5W | *7, *8 | W5W/1 | 26 July 2013 |
| | W10W | *7, *8 | W10W/1 | 26 July 2013 |
| | WP21W | *8 | WP21W/1 to 2 | 1 September 2018 |
| | WPY21W | *8 | WP21W/1 to 2 | 1 September 2018 |
| | WY2.3W | *8 | WY2.3W/1 | 15 July 2015 |
| | WY5W | *7, *8 | W5W/1 | 15 July 2014 |
| | WY10W | *7, *8 | W10W/1 | 26 July 2013 |

* Tables, Electrical and Photometric characteristics:

Voltage is expressed in V;

Wattage is expressed in W;

Luminous flux is expressed in lm.

In a case of a category of filament light source where more than one value of reference luminous flux is specified, the value at approximately 12 V for a lighting device and 13.5 V for a light-signalling device shall be applied unless otherwise specified by the regulation used for the device.

*² Not for use in passing beam headlamps.

*³ Not for use in front fog lamps marked "B" as defined in Regulation No. 19.

*⁴ Not for use in Regulation No. 112 headlamps.

*⁵ Not for use in headlamps other than Regulation No. 113 class C headlamps.

*⁶ All types except from 6 V type.

*⁷ 6 V types only.

*⁸ Only for use in signalling lamps, cornering lamps, reversing lamps and rear registration plate lamps.

** From the original version of this Resolution onwards, this date is 1 September following the date of adoption of (the amendment to) this Resolution by WP.29, plus a multiple of 12 months thereafter.

3.2. Gas-discharge light sources

Characteristics of categories of gas-discharge light sources as listed below are shown in Annex 2.

Luminous flux values in the light source category sheets concern white light unless otherwise specified in these sheets.

List of categories of gas-discharge light sources, grouped according to restrictions on use and their sheet numbers:

| <i>Gas-discharge light source categories only for use in passing beam, driving beam and cut-off front fog lamps:</i> | |
|--|------------------------|
| <i>Category</i> | <i>Sheet number(s)</i> |
| D1R | DxR/1 to 7 |
| D1S | DxS/1 to 6 |
| D2R | DxR/1 to 7 |
| D2S | DxS/1 to 6 |
| D3R | DxR/1 to 7 |
| D3S | DxS/1 to 6 |
| D4R | DxR/1 to 7 |
| D4S | DxS/1 to 6 |
| D5S | D5S/1 to 5 |

| <i>Gas-discharge light source categories only for use in passing beam, driving beam and cut-off front fog lamps:</i> | | | |
|--|-----------------|--|------------------------|
| | <i>Category</i> | | <i>Sheet number(s)</i> |
| | D6S | | D6S/1 to 5 |
| | D8R | | D8R/1 to 6 |
| | D8S | | D8S/1 to 5 |
| | D9S | | D9S1 to 5 |

3.3. LED light sources

Characteristics of categories of LED light sources as listed below as shown in Annex 3.

Luminous flux values in the light source category sheets concern white light unless otherwise specified in these sheets.

List of categories of LED light sources, grouped according to restrictions on use and their sheet numbers:

| <i>"RESERVED"</i> | | | |
|--|-----------------|--|------------------------|
| <i>Group 1</i> | | | |
| <i>LED light source categories without general restrictions:</i> | | | |
| | <i>Category</i> | | <i>Sheet number(s)</i> |
| | | | |

| <i>Group 2</i> | | | |
|--|-----------------|--|------------------------|
| <i>LED light source categories only for use in signalling lamps, cornering lamps, reversing lamps and rear registration plate lamps:</i> | | | |
| | <i>Category</i> | | <i>Sheet number(s)</i> |
| | LR1 | | LR1/1 to 5 |
| | LW2 | | LW2/1 to 5 |
| | LR3A | | L3/1 to 6 |
| | LR3B | | L3/1 to 6 |
| | LW3A | | L3/1 to 6 |
| | LW3B | | L3/1 to 6 |
| | LY3A | | L3/1 to 6 |
| | LY3B | | L3/1 to 6 |
| | LR4A | | LR4/1 to 5 |
| | LR4B | | LR4/1 to 5 |
| | LR5A | | L5/1 to 6 |
| | LR5B | | L5/1 to 6 |
| | LW5A | | L5/1 to 6 |

| | | | |
|--|-----------------|--|------------------------|
| <i>Group 2</i> | | | |
| <i>LED light source categories only for use in signalling lamps, cornering lamps, reversing lamps and rear registration plate lamps:</i> | | | |
| | <i>Category</i> | | <i>Sheet number(s)</i> |
| | LW5B | | L5/1 to 6 |
| | LY5A | | L5/1 to 6 |
| | LY5B | | L5/1 to 6 |

Annex 1

Sheets for filament light sources

List of sheets for filament light sources and their sequence in this annex:

Sheet number(s)

C5W/1

C21W/1 to 2

H1/1 to 3

H3/1 to 4

H4/1 to 5

H7/1 to 4

H8/1 to 4

H9/1 to 4

H10/1 to 3

H11/1 to 4

H12/1 to 3

H13/1 to 4

H14/1 to 4

H15/1 to 5

H16/1 to 4

H17/1 to 6

H18/1 to 4

H19/1 to 5

H20/1 to 4

H6W/1

H10W/1 to 2

H21W/1 to 2

H27W/1 to 3

HB3/1 to 4

HB4/1 to 4

HIR1/1 to 3

HIR2/1 to 3

HS1/1 to 5

HS2/1 to 3

HS5/1 to 4

HS5A/1 to 3

HS6/1 to 4

P13W/1 to 3

P19W/1 to 3

Sheet number(s)

P21W/1 to 2
P21/4W/1
P21/5W/1 to 3
P24W/1 to 3
P27W/1 to 2
P27/7W/1 to 3
PC16W/1 to 3
PR21W/1
PR21/4W/1
PR21/5W/1
PR27/7W/1
PSX26W/1 to 3
PY21W/1
PY21/5W/1 to 3
PY27/7W/1
R2/1 to 3
R5W/1
R10W/1
S1/S2/1 to 2
S3/1
T1.4W/1
T4W/1
W2.3W/1
W3W/1
W5W/1
W10W/1
W15/5W/1 to 3
W16W/1
W21W/1 to 2
W21/5W/1 to 3
WP21W/1 to 2
WR21/5W/1
WT21W/1 to 2
WT21/7W/1 to 3
WY2.3W/1
WY21W/1 to 2

Category C5W

Sheet C5W/1

The drawings are intended only to illustrate the essential dimensions (in mm) of the filament light source

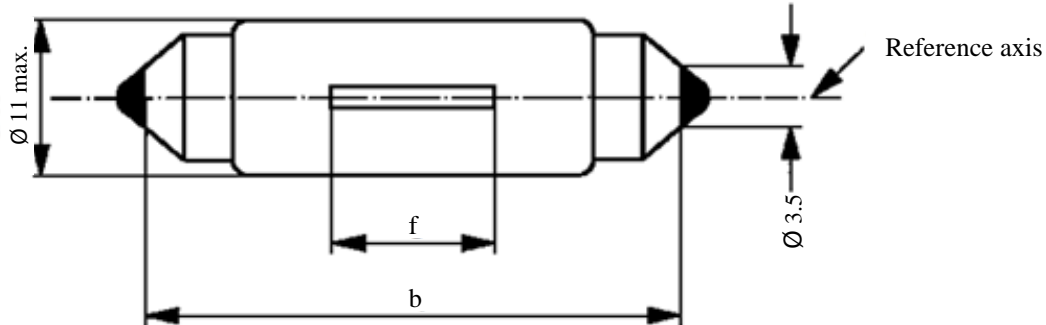

| Dimensions in mm | Filament light sources of normal production | | | Standard filament light source | |
|--|---|-----------|------------------|--------------------------------|----------|
| | Min. | Nom. | Max. | | |
| b ^{1/} | 34.0 | 35.0 | 36.0 | 35.0 ± 0.5 | |
| f ^{2/,3/} | 7.5 ^{4/} | | 15 ^{5/} | 9 ± 1.5 | |
| Cap SV8.5 in accordance with IEC Publication 60061 (sheet 7004-81-4) | | | | | |
| Electrical and photometric characteristics | | | | | |
| Rated values | Volts | 6 | 12 | 24 | 12 |
| | Watts | 5 | | | 5 |
| Test voltage | Volts | 6.75 | 13.5 | 28.0 | 13.5 |
| Objective values | Watts | 5.5 max. | | 7.7 max. | 5.5 max. |
| | Luminous flux | 45 ± 20 % | | | |
| Reference luminous flux: 45 lm at approximately 13.5 V | | | | | |

^{1/} This dimension corresponds to a distance between two apertures of 3.5 mm diameter each bearing against one of the caps.

^{2/} The filament shall be housed in a cylinder 19 mm long co-axial with the filament light source and placed symmetrically about the filament light source centre.
The diameter of the cylinder is for 6 V and 12 V filament light sources: d + 4 mm (for standard filament light sources: d + 2 mm) and for 24 V filament light sources: d + 5 mm, "d" being the nominal diameter of the filament as stated by the manufacturer.

^{3/} The deviation of the filament centre from the centre of the filament light source shall not be more than ±2.0 mm (for standard filament light sources: ±0.5 mm) measured in the direction of the reference axis.

^{4/} 4.5 mm for 6 V filament light sources.

^{5/} 16.5 mm for 24 V filament light sources.

The drawings are intended only to illustrate the essential dimensions (in mm) of the filament light source

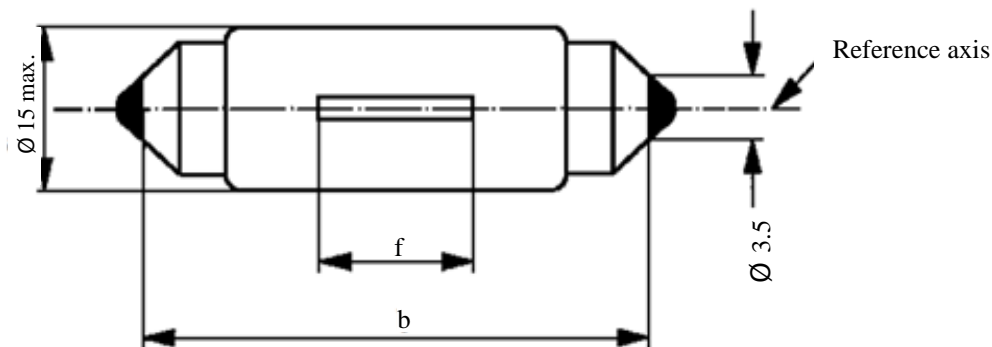

| Dimensions in mm | Filament light sources of normal production | | | Standard filament light source |
|--|---|------------|------|--------------------------------|
| | Min. | Nom. | Max. | |
| b ^{1/} | 40.0 | 41.0 | 42.0 | 41.0 ± 0.5 |
| f ^{2/} | 7.5 | | 10.5 | 8 ± 1.0 |
| Cap SV8.5 in accordance with IEC Publication 60061 (sheet 7004-81-4) | | | | |
| Electrical and photometric characteristics | | | | |
| Rated values | Volts | 12 | | 12 |
| | Watts | 21 | | 21 |
| Test voltage | Volts | 13.5 | | 13.5 |
| Objective values | Watts | 26.5 max. | | 26.5 max. |
| | Luminous flux | 460 ± 15 % | | |
| Reference luminous flux: 460 lm at approximately 13.5 V | | | | |

^{1/} This dimension corresponds to a distance between two apertures of 3.5 mm diameter.

^{2/} The position of the filament is checked by means of a "Box system"; sheet C21W/2.

Screen projection requirements

This test is used to determine, by checking whether the filament is correctly positioned relative to the reference axis and to the centre of the filament light source's length, whether a filament light source complies with the requirements.

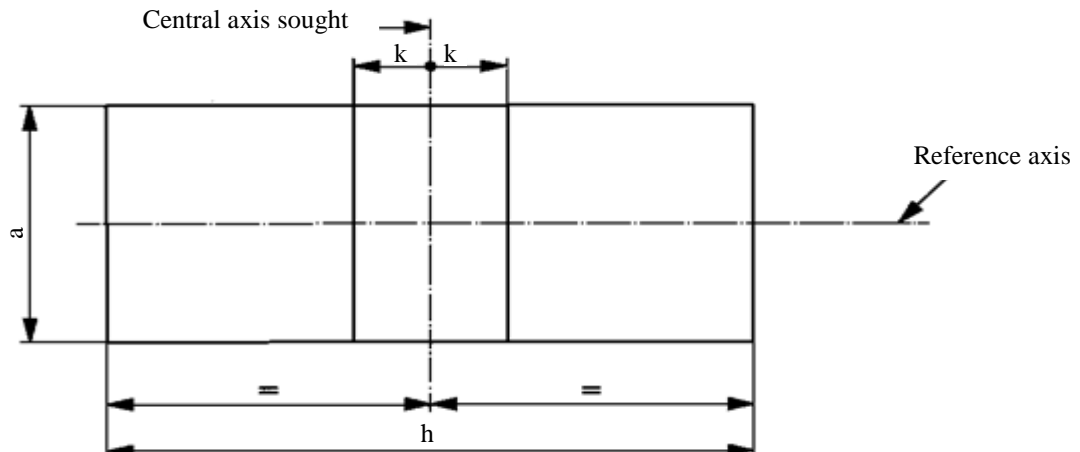

| 12 V | a | h | k |
|---|-----------|------|-----|
| Filament light sources of normal production | $4.0 + d$ | 14.5 | 2.0 |
| Standard filament light source | $2.0 + d$ | 14.5 | 0.5 |

d = nominal filament diameter as stated by the manufacturer.

Test procedure and requirements

1. The filament light source is placed in a holder (socket) capable of being so rotated through 360° about the reference axis that the front elevation is seen on the screen on to which the image of the filament is projected. The reference plane on the screen shall coincide with the centre of the filament light source. The central axis sought on the screen shall coincide with the centre of the filament light source length.
2. Front elevation
 - 2.1. The projection of the filament shall lie entirely within the rectangle when the filament light source is rotated through 360° .
 - 2.2. The centre of the filament shall not be offset by more than distance " k " from the central axis sought.

The drawings are intended only to illustrate the essential dimensions (in mm) of the filament light source

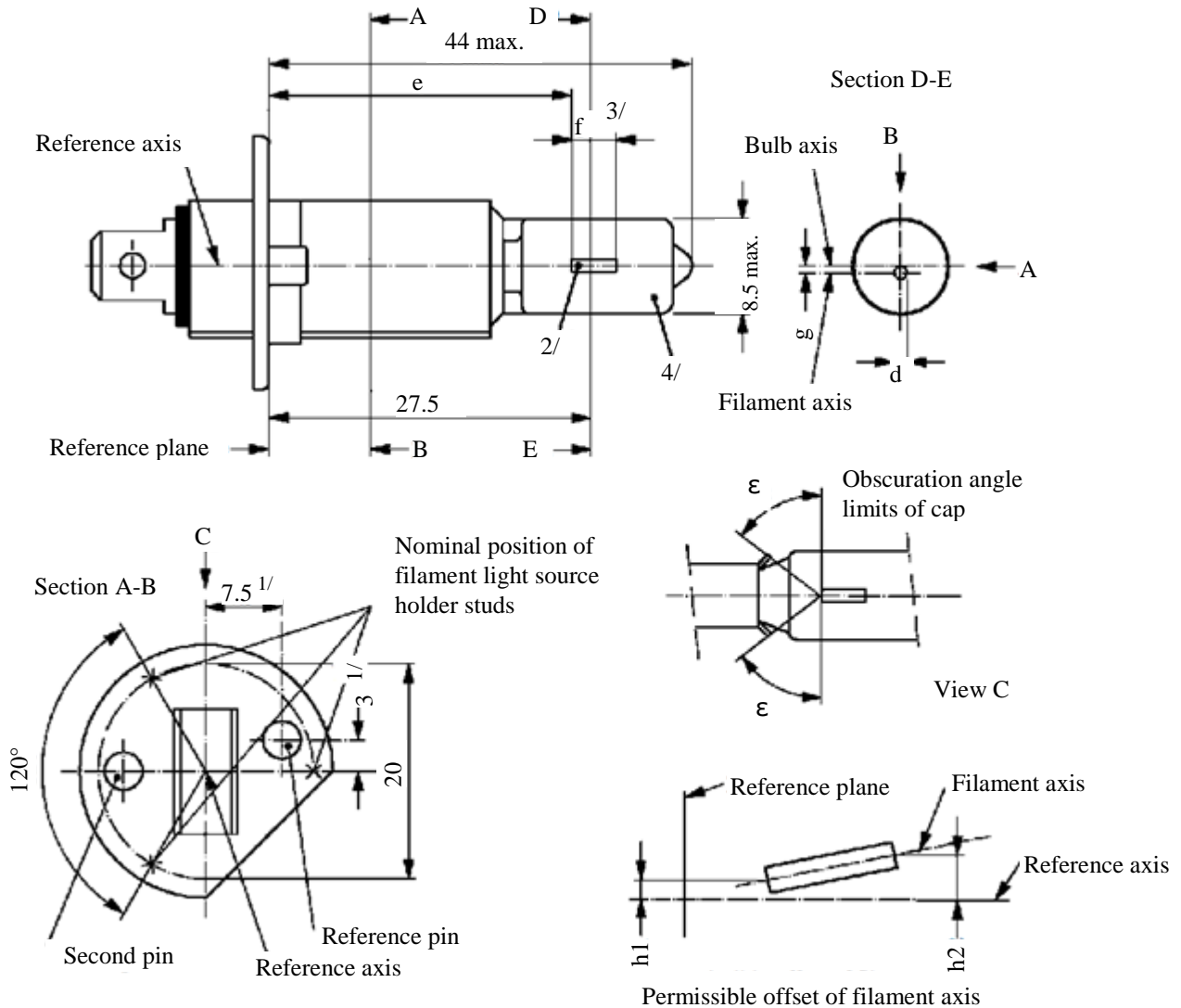

- 1/ The reference axis is perpendicular to the reference plane and passes through the point defined by the dimensions marked with 1.
- 2/ Both current lead-in legs shall be positioned in the bulb, the longer leg above the filament (the filament light source being viewed as shown in the figure). The internal design should be then such that stray light images and reflections are reduced to the minimum, e.g. by fitting cooling jackets over the non-coiled parts of the filament.
- 3/ The cylindrical portion of the bulb over length "f" shall be such as not to deform the projected image of the filament to such an extent as appreciably to affect the optical results.
- 4/ The colour of the light emitted shall be white or selective-yellow.

Category H1

Sheet H1/2

| Dimensions in mm | Filament light sources of normal production | | | Standard filament light source | |
|---|---|-----------|-----------|--------------------------------|---------|
| | 6 V | 12 V | 24 V | 12 V | |
| e ^{6/,10/} | 25.0 ^{9/} | | | 25.0 ± 0.15 | |
| f ^{6/,10/} | 4.5 ± 1.0 | 5.0 ± 0.5 | 5.5 ± 1.0 | 5.0 + 0.50 / -0.00 | |
| g ^{7/,8/} | 0.5 d ± 0.5 d | | | 0.5 d ± 0.25 d | |
| h1 | ^{9/} | | | 0 ± 0.20 ^{5/} | |
| h2 | ^{9/} | | | 0 ± 0.25 ^{5/} | |
| ε | 45° ± 12° | | | 45° ± 3° | |
| Cap P14.5s in accordance with IEC Publication 60061 (sheet 7004-46-2) | | | | | |
| Electrical and photometric characteristics | | | | | |
| Rated values | Volts | 6 | 12 | 24 | 12 |
| | Watts | 55 | | 70 | 55 |
| Test Voltage | Volts | 6.3 | 13.2 | 28.0 | 13.2 |
| Objective values | Watts | 63 max. | 68 max. | 84 max. | 68 max. |
| | Luminous flux ± % | 1,350 | 1,550 | 1,900 | |
| | | 15 | | | |
| Reference luminous flux at approximately | | | 12 V | 1,150 | |
| | | | 13.2 V | 1,550 | |

^{5/} The eccentricity is measured only in the horizontal and vertical directions of the filament light source as shown in the figure. The points to be measured are those where the projections of the outside of the end turns nearest to or furthest from the reference plane crosses the filament axis.

^{6/} The viewing direction is the perpendicular to the reference axis contained in the plane defined by the reference axis and the centre of the second pin of the cap.

^{7/} Offset of filament in relation to bulb axis measured at 27.5 mm from the reference plane.

^{8/} d: diameter of filament.

^{9/} To be checked by means of a "Box system", sheet H1/3.

^{10/} The ends of the filament are defined as the points where, when the viewing direction is as defined in footnote 6/ above, the projection of the outside of the end turns nearest to or furthest from the reference plane crosses the reference axis (special instructions for coiled-coil filaments are under consideration).

Screen projection requirements

This test is used to determine, by checking whether the filament is correctly positioned relative to the reference axis and reference plane, whether a filament light source complies with the requirements.

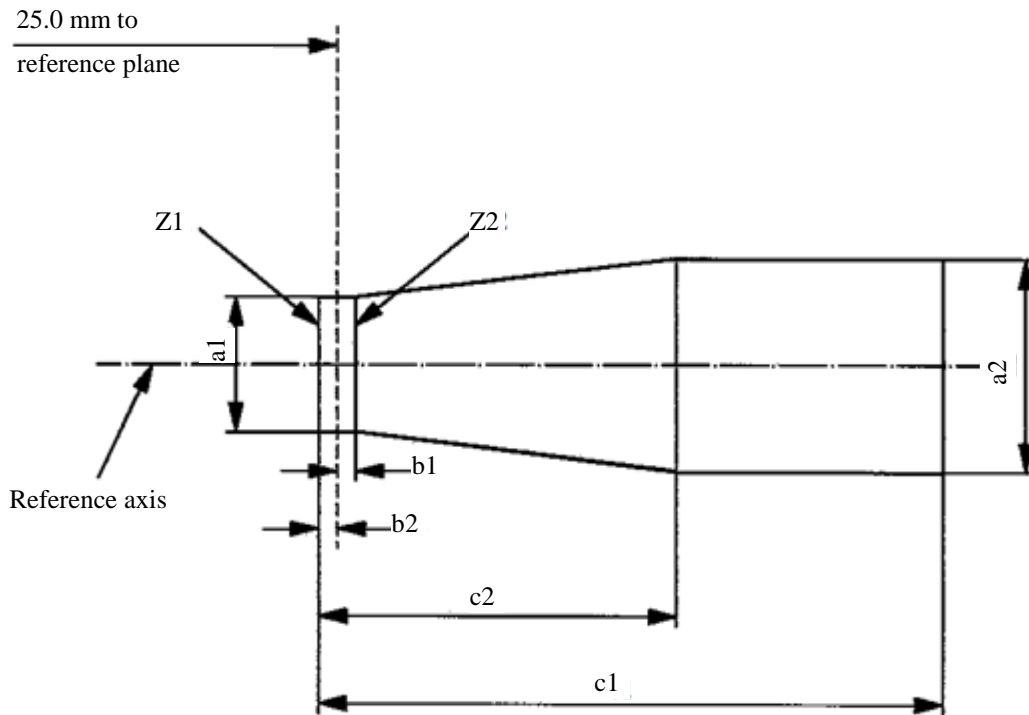

| | <i>a1</i> | <i>a2</i> | <i>b1</i> | <i>b2</i> | <i>c1</i> | <i>c2</i> |
|------|-----------|-----------|-----------|-----------|-----------|-----------|
| 6 V | 1.4d | 1.9 d | 0.25 | | 6 | 3.5 |
| 12 V | | | | | 6 | 4.5 |
| 24 V | | | | | 7 | 4.5 |

d = diameter of filament.

The filament position is checked solely in directions A and B as shown on sheet H1/1.

The filament shall lie entirely within the limits shown.

The beginning of the filament as defined on sheet H1/2, footnote 10/, shall lie between lines Z1 and Z2.

The drawings are intended only to illustrate the essential dimensions (in mm) of the filament light source

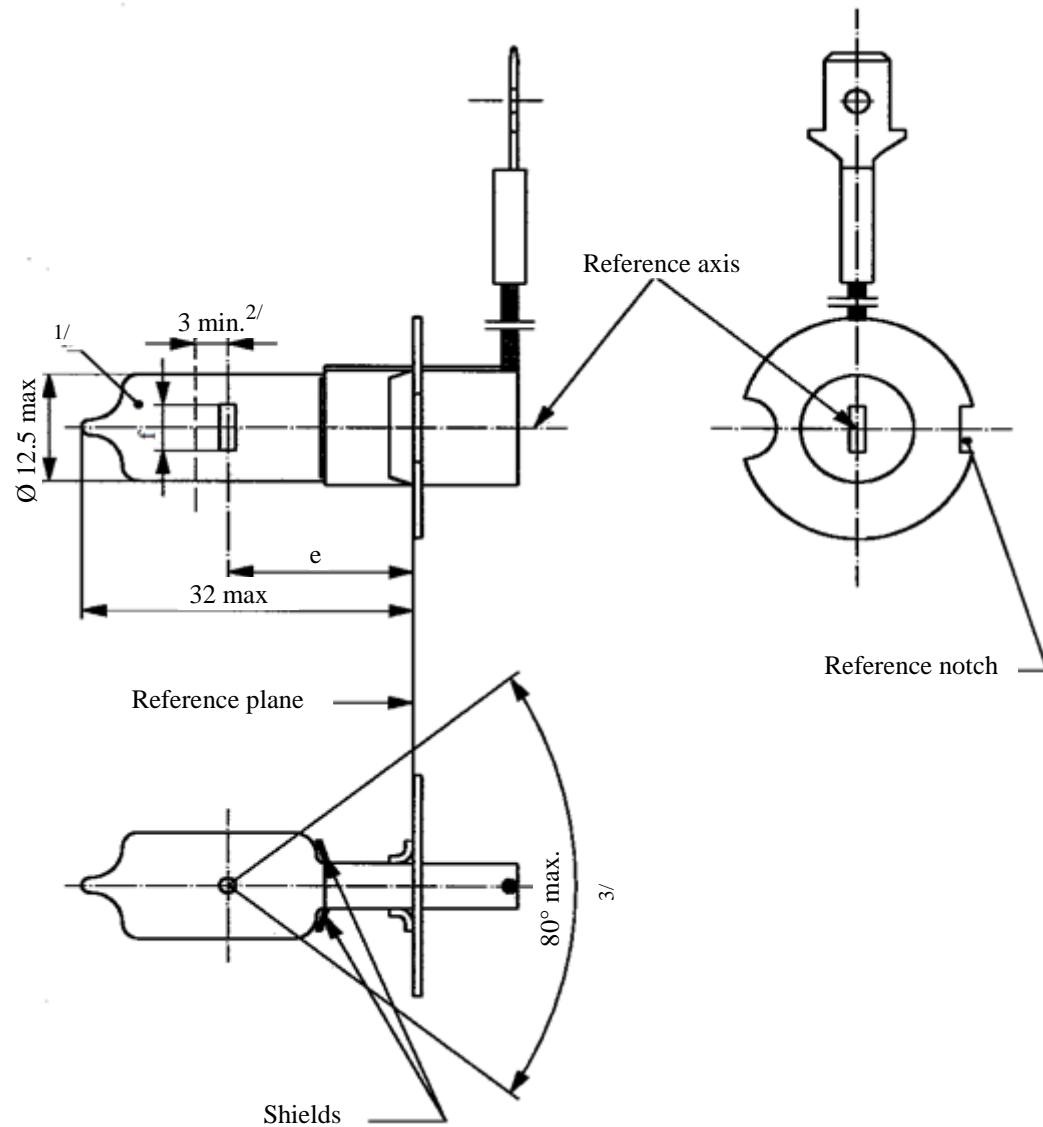

^{1/} The colour of the light emitted shall be white or selective-yellow.

^{2/} Minimum length above the height of the light emitting centre ("e") over which the bulb shall be cylindrical.

^{3/} The distortion of the base-end portion of the bulb shall not be visible from any direction outside the obscuration angle of 80° max. The shields shall produce no inconvenient reflections. The angle between the reference axis and the plane of each shield, measured on the bulb side, shall not exceed 90° .

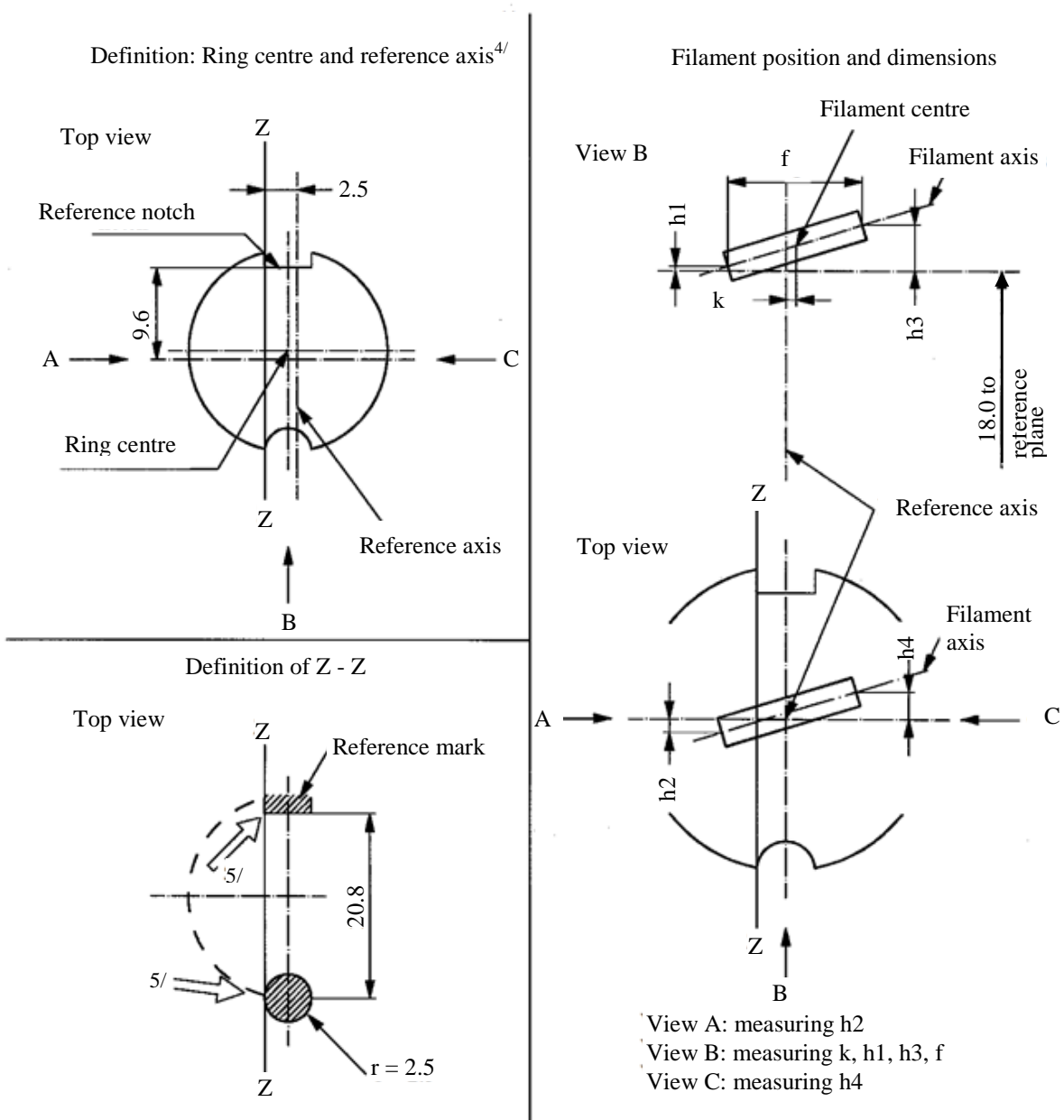

^{4/} The permissible deviation of the ring centre from the reference axis is 0.5 mm in the direction perpendicular to the Z-Z line and 0.05 mm in the direction parallel to the Z-Z line.

^{5/} The cap shall be pressed in these directions.

Category H3

Sheet H3/3

| <i>Dimensions in mm</i> | | <i>Filament light sources of normal production</i> | | | <i>Standard filament light source</i> |
|--|--------------------|--|-------------|------------------------|---------------------------------------|
| | | <i>6 V</i> | <i>12 V</i> | <i>24 V</i> | <i>12 V</i> |
| e | 18.0 ^{6/} | | | 18.0 | |
| f ^{8/} | 3.0 min. | 4.0 min. | | 5.0 ± 0.50 | |
| k | 0 ^{6/} | | | 0 ± 0.20 | |
| h1, h3 | 0 ^{6/} | | | 0 ± 0.15 ^{7/} | |
| h2, h4 | 0 ^{6/} | | | 0 ± 0.25 ^{7/} | |
| Cap PK22s in accordance with IEC Publication 60061 (sheet 7004-47-4) | | | | | |
| Electrical and photometric characteristics | | | | | |
| Rated values | Volts | 6 | 12 | 24 | 12 |
| | Watts | 55 | | 70 | 55 |
| Test voltage | Volts | 6.3 | 13.2 | 28.0 | 13.2 |
| Objective values | Watts | 63 max. | 68 max. | 84 max. | 68 max. |
| | Luminous flux | 1,050 | 1,450 | 1,750 | |
| | ± % | 15 | | | |
| Reference luminous flux at approximately | | | | 12 V | 1,100 |
| | | | | 13.2 V | 1,450 |

^{6/} To be checked by means of a "Box system"; sheet H3/4.

^{7/} For standard filament light sources the points to be measured are those where the projection of the outside of the end turns crosses the filament axis.

^{8/} The positions of the first and the last turn of the filament are defined by the intersections of the outside of the first and of the last light emitting turn, respectively, with the plane parallel to and 18 mm distant from the reference plane. (Additional instructions for coiled-coil filament are under consideration).

Screen projection requirements

This test is used to determine, by checking whether the filament is correctly positioned relative to the reference axis and reference plane, whether a filament complies with the requirements.

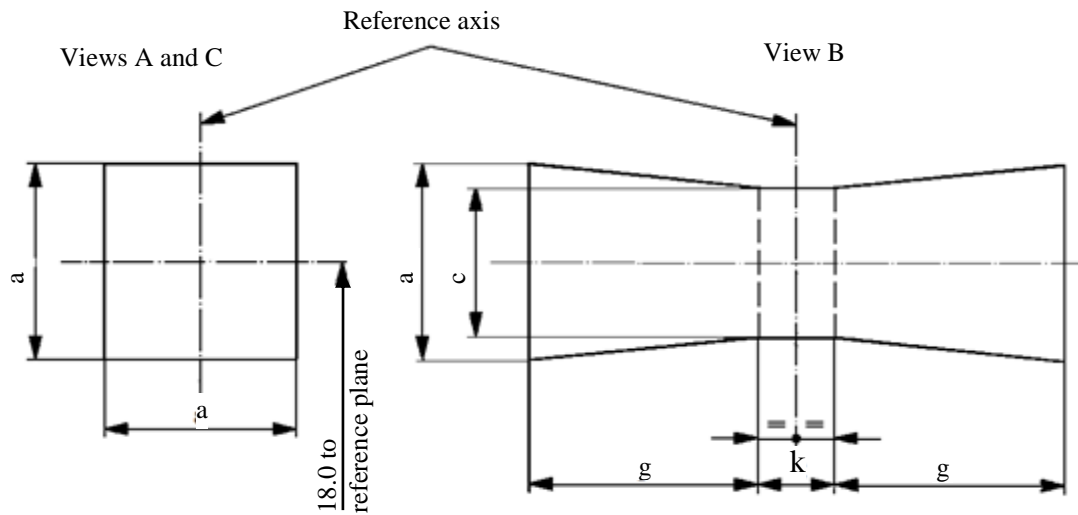

| | <i>a</i> | <i>c</i> | <i>k</i> | <i>g</i> |
|------|----------|----------|----------|----------|
| 6 V | 1.8 d | 1.6 d | 1.0 | 2.0 |
| 12 V | | | | 2.8 |
| 24 V | | | | 2.9 |

d = diameter of filament

The filament shall lie entirely within the limits shown.

The centre of the filament shall lie within the limits of dimension k.

The drawings are intended only to illustrate the essential dimensions (in mm) of the filament light source

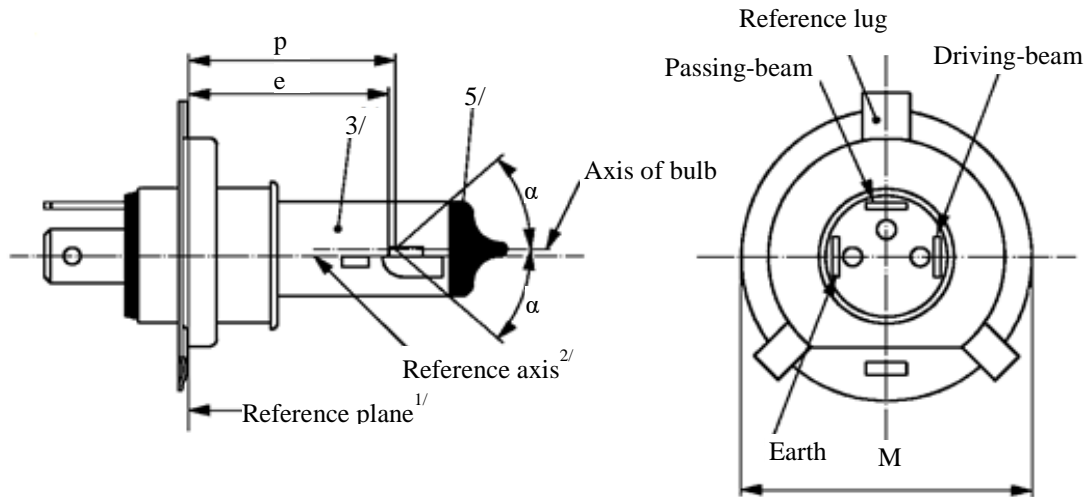

Figure 1 – Main drawing

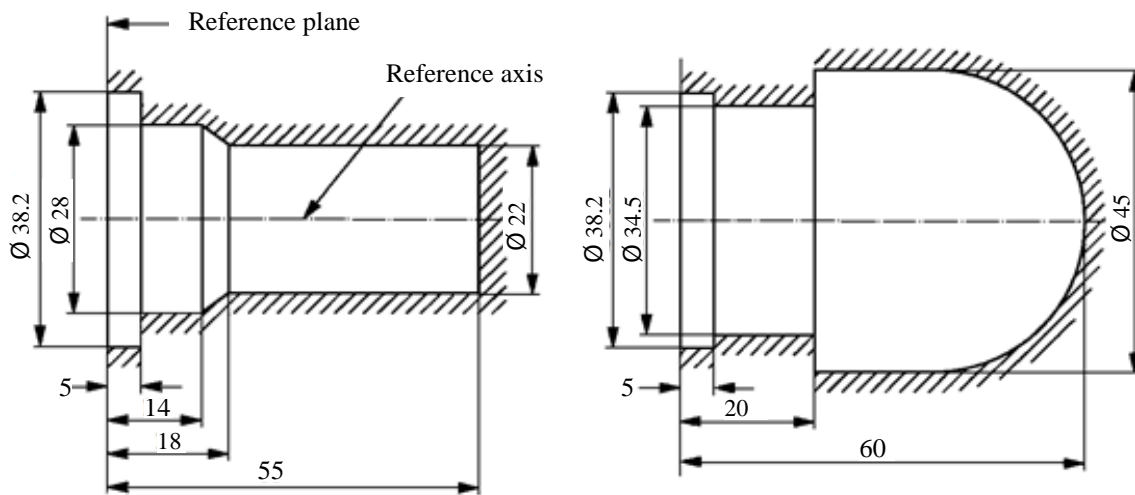

Figure 2

Maximum filament light source

Figure 3

- ^{1/} The reference plane is the plane formed by the seating points of the three lugs of the cap ring.
- ^{2/} The reference axis is perpendicular to the reference plane and passes through the centre of the circle of diameter "M".
- ^{3/} The colour of the light emitted shall be white or selective-yellow.
- ^{4/} The bulb and supports shall not exceed the envelope as in Figure 2. However, where a selective-yellow outer bulb is used the bulb and supports shall not exceed the envelope as in Figure 3.
- ^{5/} The obscuration shall extend at least as far as the cylindrical part of the bulb. It shall also overlap the internal shield when the latter is viewed in a direction perpendicular to the reference axis.

| <i>Dimensions in mm</i> | | <i>Filament light sources of normal production</i> | | | | <i>Standard filament light source</i> | |
|---|---------------|--|---------|------------------|---------|---------------------------------------|---------|
| | | <i>12 V</i> | | <i>24 V</i> | | <i>12 V</i> | |
| e | | 28.5 +0.35/-0.25 | | 29.0 ± 0.35 | | 28.5 + 0.20 / -0.00 | |
| p | | 28.95 | | 29.25 | | 28.95 | |
| α | | max. 40° | | | | max. 40° | |
| Cap P43t in accordance with IEC Publication 60061 (sheet 7004-39-6) | | | | | | | |
| Electrical and photometric characteristics | | | | | | | |
| Rated values | Volts | 12 ^{6/} | | 24 ^{6/} | | 12 ^{6/} | |
| | Watts | 60 | 55 | 75 | 70 | 60 | 55 |
| Test voltage | Volts | 13.2 | | 28.0 | | 13.2 | |
| Objective values | Watts | 75 max. | 68 max. | 85 max. | 80 max. | 75 max. | 68 max. |
| | Luminous flux | 1,650 | 1,000 | 1,900 | 1,200 | | |
| | ± % | 15 | | | | | |
| Measuring flux ^{7/} lm | | - | 750 | - | 800 | | |
| Reference luminous flux at approximately | | | | 12 V | | 1,250 | 750 |
| | | | | 13.2 V | | 1,650 | 1,000 |

^{6/} The value indicated in the left hand column relate to the driving-beam filament. Those indicated in the right-hand column relate to the passing-beam filament.

^{7/} Measuring luminous flux according to the provisions for filament light sources with an internal shield to produce the cut-off.

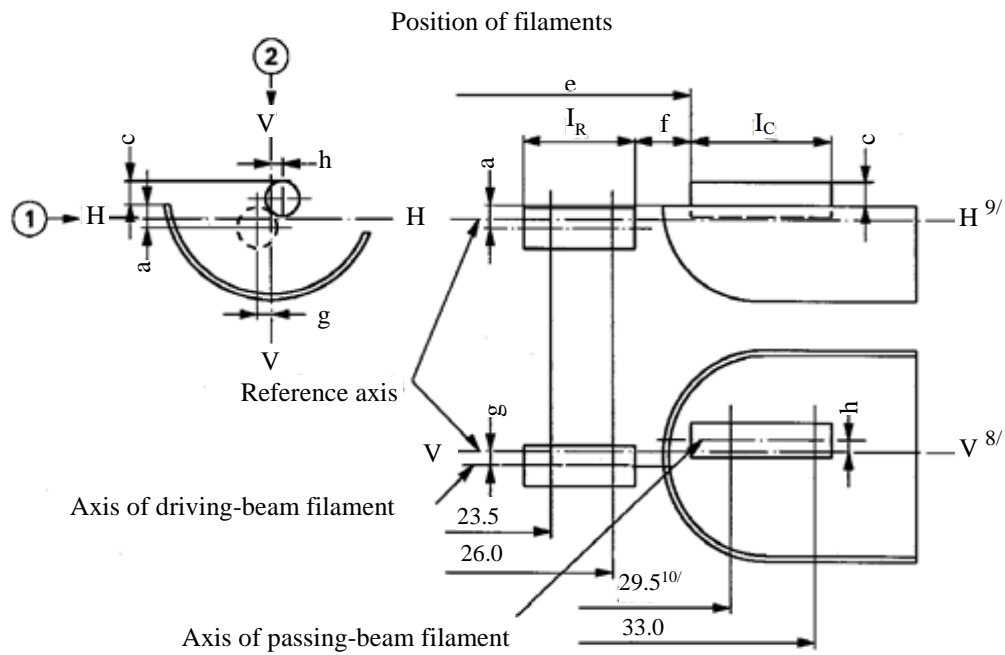
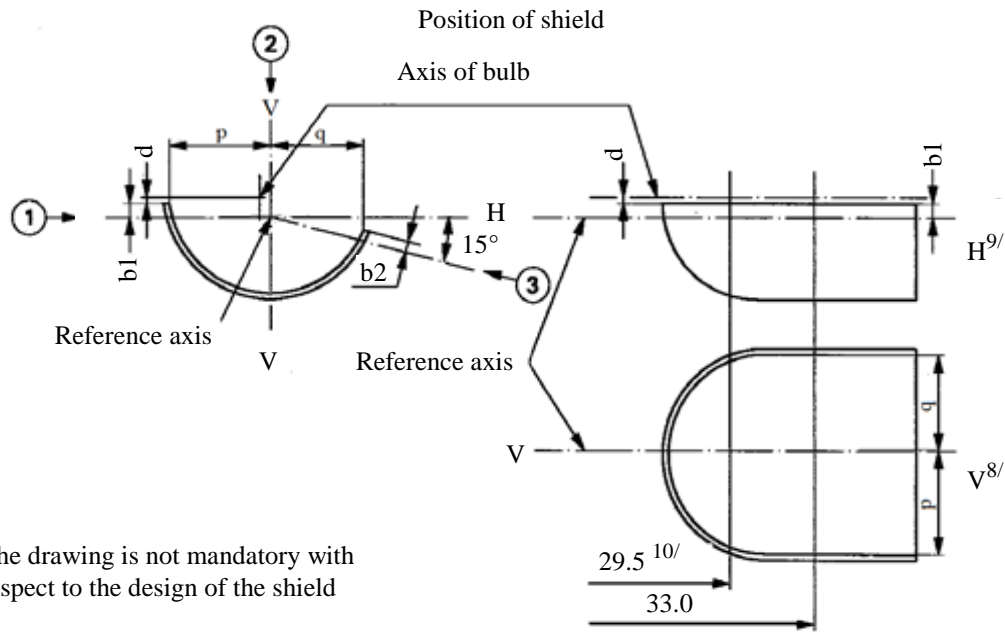

Table of the dimensions (in mm) referred to in the drawings on sheet H4/3

| Reference* | | Dimension** | | Tolerance | | |
|-----------------------------------|------|------------------------------------|------------|---|-------|--------------------------------|
| | | | | Filament light sources of normal production | | Standard filament light source |
| 12 V | 24 V | 12 V | 24 V | 12 V | 24 V | 12 V |
| a/26 | | 0.8 | | ±0.35 | | ±0.20 |
| a/23.5 | | 0.8 | | ±0.60 | | ±0.20 |
| b1/29.5 | 30.0 | 0 | | ±0.30 | ±0.35 | ±0.20 |
| b1/33 | | b1/29.5 mv | b1/30.0 mv | ±0.30 | ±0.35 | ±0.15 |
| b2/29.5 | 30.0 | 0 | | ±0.30 | ±0.35 | ±0.20 |
| b2/33 | | b2/29.5 mv | b2/30.0 mv | ±0.30 | ±0.35 | ±0.15 |
| c/29.5 | 30.0 | 0.6 | 0.75 | ±0.35 | | ±0.20 |
| c/33 | | c/29.5 mv | c/30.0 mv | ±0.35 | | ±0.15 |
| d | | min. 0.1 | | - | | - |
| e ^{13/} | | 28.5 | 29.0 | +0.35 -0.25 | ±0.35 | +0.20 -0.00 |
| f ^{11/,12/,13/} | | 1.7 | 2.0 | +0.50 -0.30 | ±0.40 | +0.30 -0.10 |
| g/26 | | 0 | | ±0.50 | | ±0.30 |
| g/23.5 | | 0 | | ±0.70 | | ±0.30 |
| h/29.5 | 30.0 | 0 | | ±0.50 | | ±0.30 |
| h/33 | | h/29.5 mv | h/30.0 mv | ±0.35 | | ±0.20 |
| I _R ^{11/,14/} | | 4.5 | 5.25 | ±0.80 | | ±0.40 |
| I _C ^{11/,14/} | | 5.5 | 5.25 | ±0.50 | ±0.80 | ±0.35 |
| p/33 | | Depends on the shape of the shield | | - | | - |
| q/33 | | (p+q)/2 | | ±0.60 | | ±0.30 |

* ".../26" means dimension to be measured at the distance from the reference plane indicated in mm after the stroke.

** "29.5 mv" or "30.0 mv" means the value measured at a distance of 29.5 or 30.0 mm from the reference plane.

- ^{8/} Plane V-V is the plane perpendicular to the reference plane and passing through the reference axis and through the intersection of the circle of diameter "M" with the axis of the reference lug.
- ^{9/} Plane H-H is the plane perpendicular to both the reference plane and plane V-V and passing through the reference axis.
- ^{10/} 30.0 mm for the 24-volt type.
- ^{11/} The end turns of the filament are defined as being the first luminous turn and the last luminous turn that are at substantially the correct helix angle. For coiled-coil filaments, the turns are defined by the envelope of the primary coil.
- ^{12/} For the passing-beam filament, the points to be measured are the intersections, seen in direction 1, of the lateral edge of the shield with the outside of the end turns defined under footnote 11/.
- ^{13/} "e" denotes the distance from the reference plane to the beginning of the passing-beam filament as defined above.
- ^{14/} For the driving-beam filament the points to be measured are the intersections, seen in direction 1, of a plane, parallel to plane H-H and situated at a distance of 0.8 mm below it, with the end turns defined under footnote 11/.

Additional explanations to sheet H4/3

The dimensions below are measured in three directions:

- 1 For dimensions a, b1, c, d, e, f, I_R and I_C;
- 2 For dimensions g, h, p and q;
- 3 For dimension b2.

Dimensions p and q are measured in planes parallel to and 33 mm away from the reference plane.

Dimensions b1, b2, c and h are measured in planes parallel to and 29.5 mm (30.0 mm for 24 V filament light sources) and 33 mm away from the reference plane.

Dimensions a and g are measured in planes parallel to and 26.0 mm and 23.5 mm away from the reference plane.

Note: For the method of measurement, see Appendix E of IEC Publication 60809.

The drawings are intended only to illustrate the essential dimensions (in mm) of the filament light source

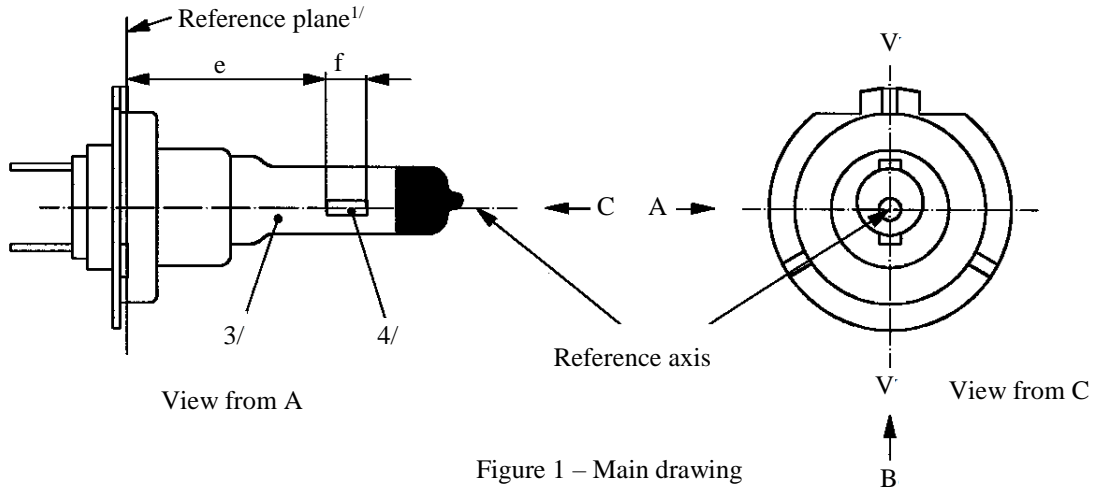

Figure 1 – Main drawing

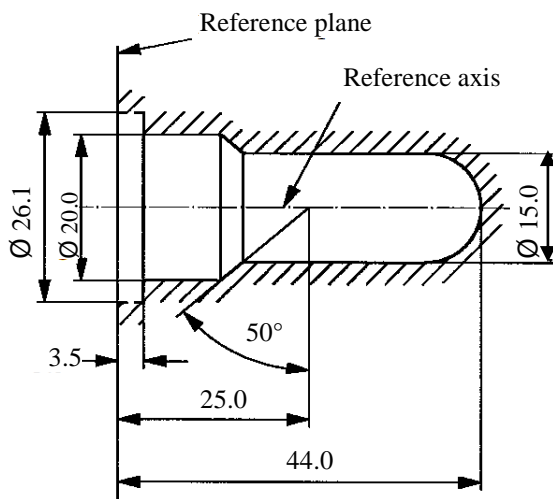

Figure 2 – Maximum filament light source outline^{5/}

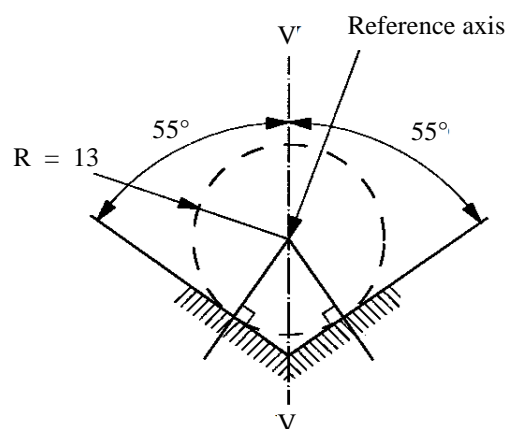
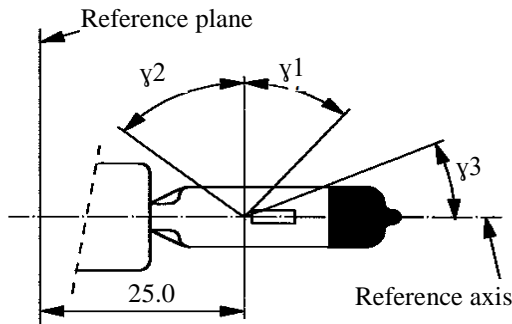

Figure 3 – Definition of reference axis^{2/}

- ^{1/} The reference plane is defined by the points on the surfaces of the holder on which the three supporting bosses of the cap ring will rest.
- ^{2/} The reference axis is perpendicular to the reference plane and crosses the intersection of the two perpendiculars as indicated in Figure 3.
- ^{3/} The colour of the light emitted shall be white or selective-yellow.
- ^{4/} Notes concerning the filament diameter.
 - (a) No actual diameter restrictions apply but the objective for future developments is to have $d_{max} = 1.3$ mm for 12 V and $d_{max} = 1.7$ for 24 V filament light sources.
 - (b) For the same manufacturer, the design diameter of standard (étalon) filament light source and filament light source of normal production shall be the same.
- ^{5/} Glass bulb and supports shall not exceed the envelope as indicated in Figure 2. The envelope is concentric to the reference axis.



View from B

Figure 4 – Distorsion free area and black top^{6/7/}

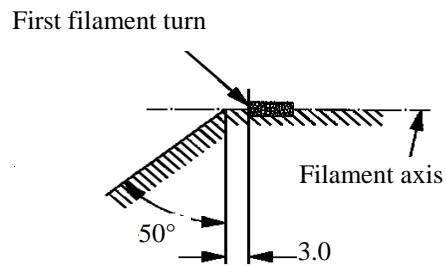

View from A

Figure 5 – Metal free zone^{8/}

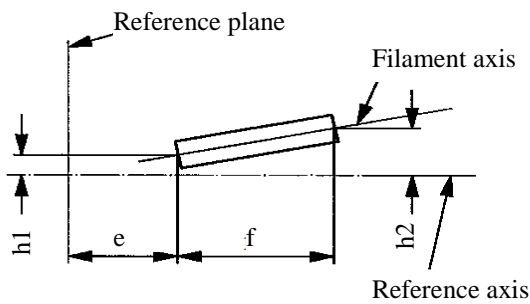
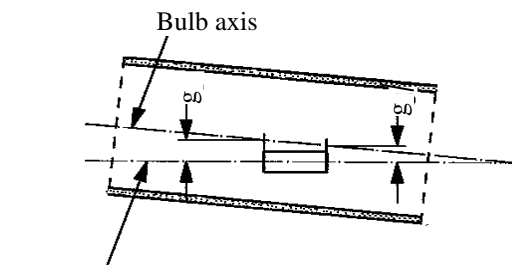

Figure 6 – Permissible offset of filament axis (for standard filament light sources only)



View from A

Figure 7 – Bulb eccentricity

- ^{6/} Glass bulb shall be optically distortion free within the angles γ_1 and γ_2 . This requirement applies to the whole bulb circumference within the angles γ_1 and γ_2 .
- ^{7/} The obscuration shall extend at least to the cylindrical part of the bulb on the whole bulb top circumference. It shall moreover extend at least to a plane parallel to the reference plane where γ_3 crosses the outer bulb surface (view B as indicated on sheet H7/1).
- ^{8/} The internal design of the filament light source shall be such that stray light images and reflections are only located above the filament itself seen from the horizontal direction. (View A as indicated in Figure 1 on sheet H7/1).
No metal parts other than filament turns shall be located in the shaded area as seen in Figure 5.

| Dimensions in mm | Filament light sources of normal production | | Standard filament light source | |
|---|---|--------------------|--------------------------------|---------|
| | 12 V | 24 V | 12 V | |
| e ^{9/} | 25.0 ^{10/} | | 25.0 ± 0.1 | |
| f ^{9/} | 4.1 ^{10/} | 4.9 ^{10/} | 4.1 ± 0.1 | |
| g ^{12/} | 0.5 min. | | u.c. | |
| h1 ^{11/} | 0 ^{10/} | | 0 ± 0.10 | |
| h2 ^{11/} | 0 ^{10/} | | 0 ± 0.15 | |
| γ1 | 40° min. | | 40° min. | |
| γ2 | 50° min. | | 50° min. | |
| γ3 | 30° min. | | 30° min. | |
| Cap PX26d in accordance with IEC Publication 60061 (sheet 7004-5-7) | | | | |
| Electrical and photometric characteristics | | | | |
| Rated values | Volts | 12 | 24 | 12 |
| | Watts | 55 | 70 | 55 |
| Test voltage | Volts | 13.2 | 28.0 | 13.2 |
| Objective values | Watts | 58 max. | 75 max. | 58 max. |
| | Luminous flux | 1,500 ± 10 % | 1,750 ± 10 % | |
| Reference luminous flux at approximately | | | 12 V | 1,100 |
| | | | 13.2 V | 1,500 |

^{9/} The ends of the filament are defined as the points where, when the viewing direction is direction A as shown in Figure 1 on sheet H7/1, the projection of the outside of the end turns crosses the filament axis. (Special instructions for coiled-coil filaments are under consideration).

^{10/} To be checked by means of a "Box system", sheet H7/4.

^{11/} The offset of the filament with respect to the reference axis is measured only in viewing directions A and B as shown in Figure 1 in sheet H7/1. The points to be measured are those where the projection of the outside of the end turns nearest to or furthest from the reference plane crosses the filament axis.

^{12/} Offset of filament in relation to bulb axis measured in two planes parallel to the reference plane where the projection of the outside of the end turns nearest to or furthest from the reference plane crosses the filament axis.

Screen projection requirements

This test is used to determine, by checking whether the filament is correctly positioned relative to the reference axis and reference plane, whether a filament light source complies with the requirements.

Dimensions in mm

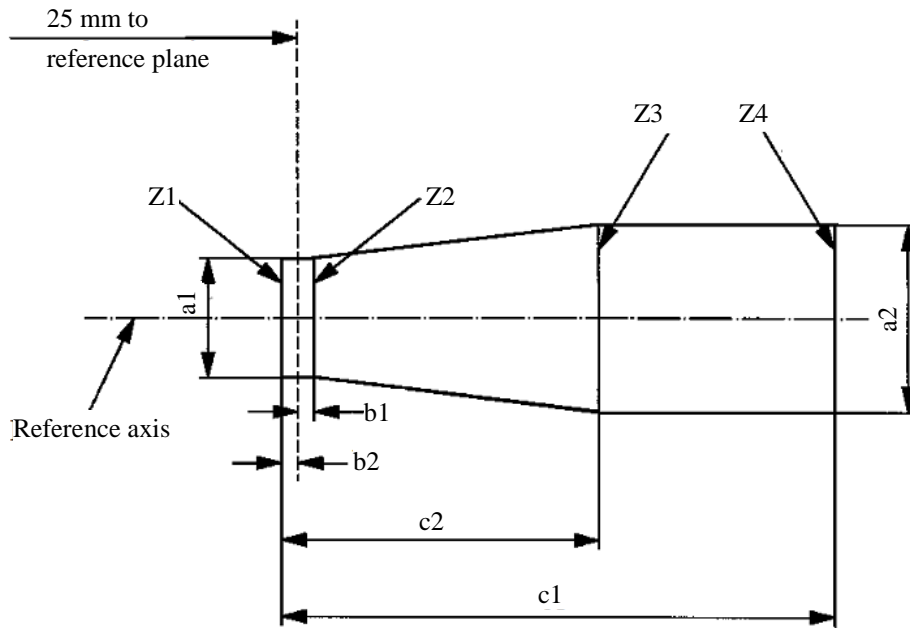

| | a_1 | a_2 | b_1 | b_2 | c_1 | c_2 |
|------|------------|------------|-------|-------|-------|-------|
| 12 V | $d + 0.30$ | $d + 0.50$ | 0.2 | | 4.6 | 4.0 |
| 24V | $d + 0.60$ | $d + 1.00$ | 0.25 | | 5.9 | 4.4 |

d = diameter of filament

The filament position is checked solely in directions A and B as shown on sheet H7/1, Figure 1.

The filament shall lie entirely within the limits shown.

The ends of the filament as defined on sheet H7/3, footnote 9/, shall lie between lines Z1 and Z2 and between Z3 and Z4.

The drawings are intended only to illustrate the essential dimensions (in mm) of the filament light source

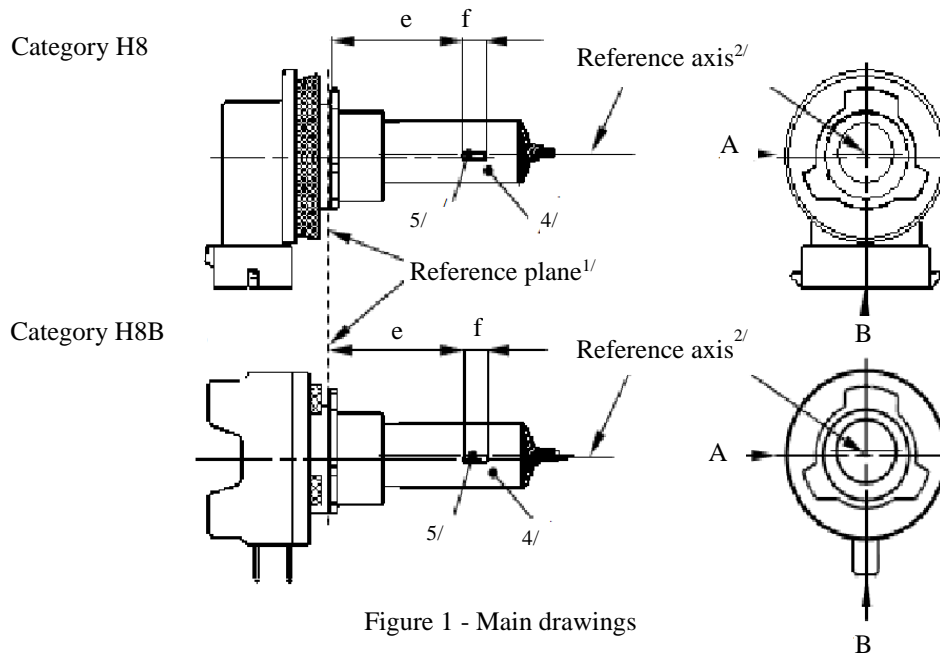

Figure 1 - Main drawings

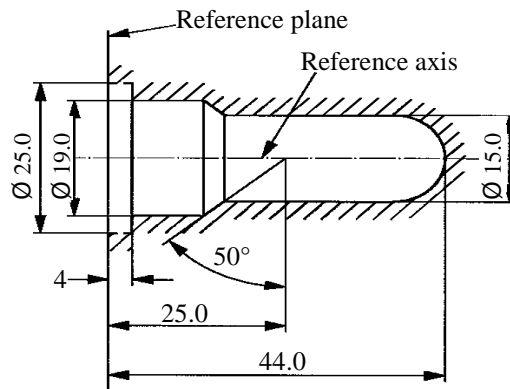
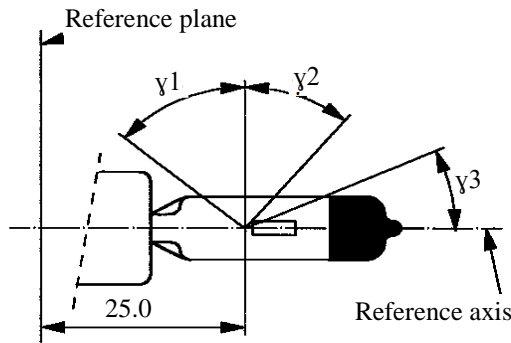
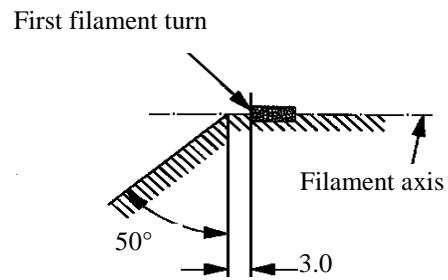

Figure 2 - Maximum filament light source outline^{3/}

- ^{1/} The reference plane is the plane formed by the underside of the bevelled lead-in flange of the cap.
- ^{2/} The reference axis is perpendicular to the reference plane and passing through the centre of the 19 mm cap diameter.
- ^{3/} Glass bulb and supports shall not exceed the envelope as indicated in Figure 2. The envelope is concentric to the reference axis.
- ^{4/} The colour of the light emitted shall be white or selective-yellow.
- ^{5/} Notes concerning the filament diameter.
 - (a) No actual diameter restrictions apply but the objective for future developments is to have $d_{max.} = 1.2$ mm.
 - (b) For the same manufacturer, the design diameter of standard (étalon) filament light source and filament light source of normal production shall be the same.



View B
Figure 3 – Distorsion free area^{6/} and black top^{7/}



View A
Figure 4 – Metal free zone^{8/}

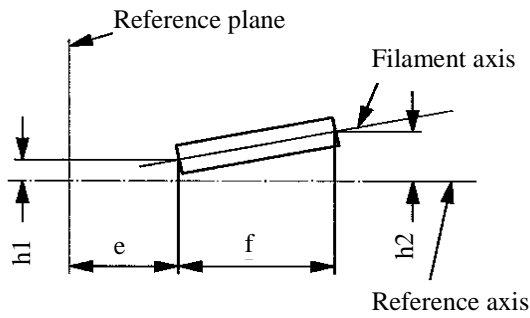

Figure 5 – Permissible offset of filament axis^{9/}
(for standard filament light sources only)

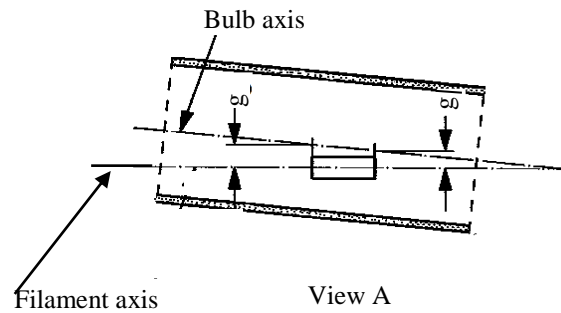

Figure 6 – Bulb eccentricity^{10/}

- ^{6/} Glass bulb shall be optically distortion free within the angles γ_1 and γ_2 . This requirement applies to the whole bulb circumference within the angles γ_1 and γ_2 .
- ^{7/} The obscuration shall extend at least to the cylindrical part of the bulb on the whole bulb top circumference. It shall moreover extend at least to a plane parallel to the reference plane where γ_3 crosses the outer bulb surface (view B as indicated on sheet H8/1).
- ^{8/} The internal design of the filament light source shall be such that stray light images and reflections are only located above the filament itself seen from the horizontal direction. (View A as indicated in Figure 1 on sheet H8/1). No metal parts other than filament turns shall be located in the shaded area as seen in Figure 4.
- ^{9/} The offset of the filament with respect to the reference axis is measured only in viewing directions A and B as shown in Figure 1 in sheet H8/1. The points to be measured are those where the projection of the outside of the end turns nearest to or furthest from the reference plane crosses the filament axis.
- ^{10/} Offset of filament in relation to bulb axis measured in two planes parallel to the reference plane where the projection of the outside of the end turns nearest to or furthest from the reference plane crosses the filament axis.

| <i>Dimensions in mm</i> | <i>Filament light sources of normal production</i> | | <i>Standard filament light source</i> |
|--|--|---|---------------------------------------|
| | <i>12 V</i> | | <i>12 V</i> |
| e ^{11/} | 25.0 ^{12/} | | 25.0 ± 0.1 |
| f ^{11/} | 3.7 ^{12/} | | 3.7 ± 0.1 |
| g | 0.5 min. | | u.c. |
| h1 | 0 ^{12/} | | 0 ± 0.1 |
| h2 | 0 ^{12/} | | 0 ± 0.15 |
| γ1 | 50° min. | | 50° min. |
| γ2 | 40° min. | | 40° min. |
| γ3 | 30° min. | | 30° min. |
| Cap: | H8: PGJ19-1 | in accordance with IEC Publication 60061 (sheet 7004-110-2) | |
| | H8B: PGJY19-1 | in accordance with IEC Publication 60061 (sheet 7004-146-1) | |
| Electrical and photometric characteristics | | | |
| Rated values | Volts | 12 | 12 |
| | Watts | 35 | 35 |
| Test voltage | Volts | 13.2 | 13.2 |
| Objective values | Watts | 43 max. | 43 max. |
| | Luminous flux | 800 ± 15 % | |
| Reference luminous flux at approximately | | 12 V | 600 |
| | | 13.2 V | 800 |

^{11/} The ends of the filament are defined as the points where, when the viewing direction is direction A as shown in Figure 1 on sheet H8/1, the projection of the outside of the end turns crosses the filament axis.

^{12/} To be checked by means of a "Box system"; sheet H8/4.

Screen projection requirements

This test is used to determine, by checking whether the filament is correctly positioned relative to the reference axis and reference plane, whether a filament complies with the requirements.

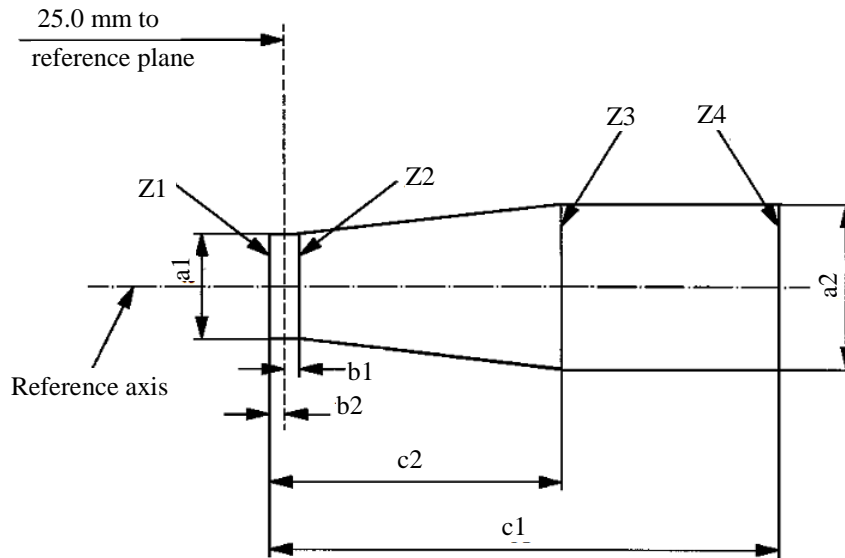

| <i>a1</i> | <i>a2</i> | <i>b1</i> | <i>b2</i> | <i>c1</i> | <i>c2</i> |
|------------|------------|-----------|-----------|-----------|-----------|
| $d + 0.50$ | $d + 0.70$ | 0.25 | | 4.6 | 3.5 |

d = diameter of filament

The filament position is checked solely in directions A and B as shown on sheet H8/1, Figure 1.

The filament shall lie entirely within the limits shown.

The ends of the filament as defined on sheet H8/3, footnote 11/, shall lie between lines Z1 and Z2 and between Z3 and Z4.

The drawings are intended only to illustrate the essential dimensions (in mm) of the filament light source

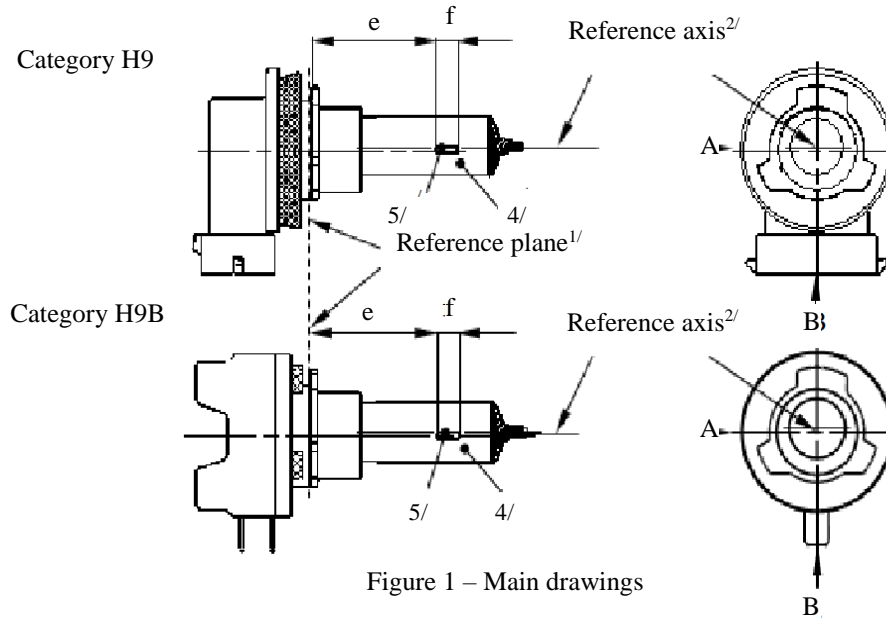

Figure 1 – Main drawings

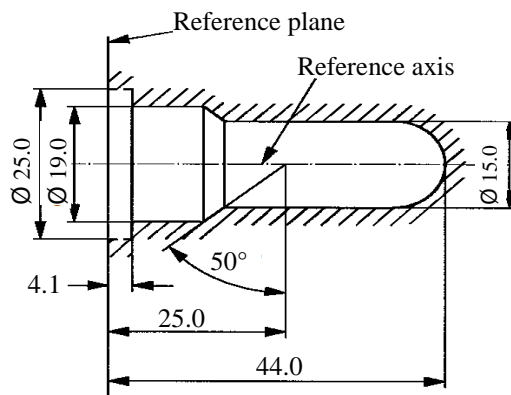
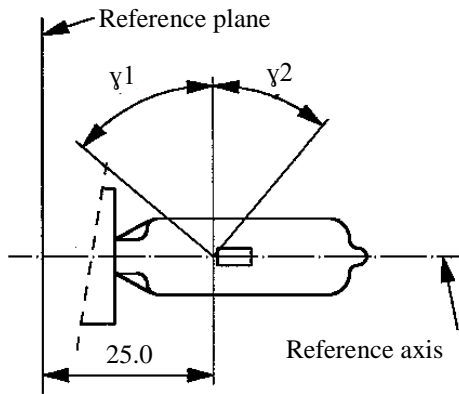

Figure 2 – Maximum filament light source outline^{3/}

- ^{1/} The reference plane is the plane formed by the underside of the bevelled lead-in flange of the cap.
- ^{2/} The reference axis is perpendicular to the reference plane and passing through the centre of the 19 mm cap diameter.
- ^{3/} Glass bulb and supports shall not exceed the envelope as indicated in Figure 2. The envelope is concentric to the reference axis.
- ^{4/} Notes concerning the filament diameter:
 - (a) No actual diameter restrictions apply but the objective for future developments is to have $d_{max} = 1.4$ mm.
 - (b) For the same manufacturer, the design diameter of standard (étalon) filament light source and filament light source of normal production shall be the same.



View B

Figure 3 – Distorsion free area^{5/}

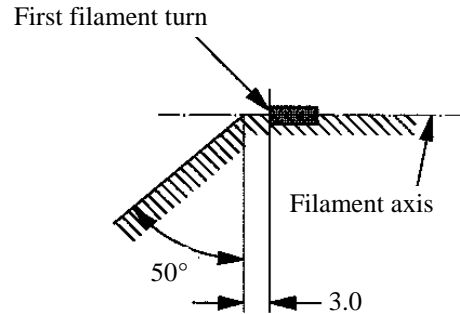

View A

Figure 4 – Metal free zone^{6/}

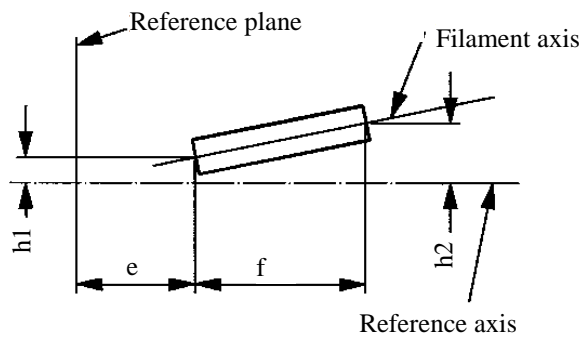

Figure 5 – Permissible offset of filament axis^{7/}
(for standard filament light sources only)

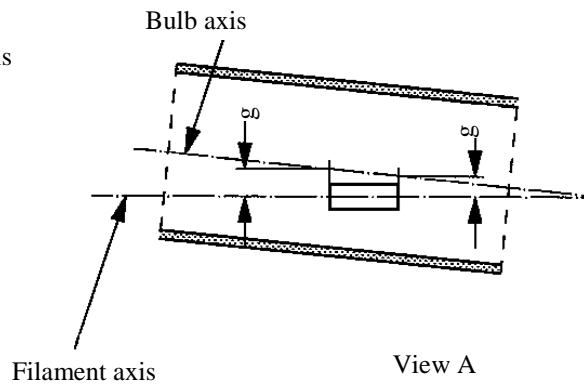

Figure 6 – Bulb eccentricity^{8/}

- ^{5/} Glass bulb shall be optically distortion free within the angles γ_1 and γ_2 . This requirement applies to the whole bulb circumference within the angles γ_1 and γ_2 .
- ^{6/} The internal design of the filament light source shall be such that stray light images and reflections are only located above the filament itself seen from the horizontal direction. (View A as indicated in Figure 1, sheet H9/1). No metal parts other than filament turns shall be located in the shaded area as seen in Figure 4.
- ^{7/} The offset of the filament with respect to the reference axis is measured only in viewing directions A and B as shown in Figure 1 on sheet H9/1. The points to be measured are those where the projection of the outside of the end turns nearest to or furthest from the reference plane crosses the filament axis.
- ^{8/} Offset of filament in relation to bulb axis measured in two planes parallel to the reference plane where the projection of the outside of the end turns nearest to or furthest from the reference plane crosses the filament axis.

| <i>Dimensions in mm</i> | | <i>Tolerance</i> | | | |
|--|------------------------------|--|--------------|---------------------------------------|---------|
| | | <i>Filament light sources of normal production</i> | | <i>Standard filament light source</i> | |
| | | <i>12 V</i> | | <i>12 V</i> | |
| e ^{9/,10/} | 25 | 11/ | | ±0.10 | |
| f ^{9/,10/} | 4.8 | 11/ | | ±0.10 | |
| g ^{9/} | 0.7 | ±0.5 | | ±0.30 | |
| h1 | 0 | 11/ | | ±0.10 ^{12/} | |
| h2 | 0 | 11/ | | ±0.15 ^{12/} | |
| γ1 | 50° min. | - | | - | |
| γ2 | 40° min. | - | | - | |
| Cap: | H9: PGJ19-5 H9B: PGJY19-5 | in accordance with IEC Publication 60061 (sheet 7004-110-2) in accordance with IEC Publication 60061 (sheet 7004-146-1) | | | |
| Electrical and photometric characteristics | | | | | |
| Rated values | Volts | 12 | | 12 | |
| | Watts | 65 | | 65 | |
| Test voltage | Volts | 13.2 | 12.2 | 13.2 | 12.2 |
| Objective values | Watts | 73 max. | 65 max. | 73 max. | 65 max. |
| | Luminous flux | 2,100 ± 10 % | 1,650 ± 10 % | | |
| Reference luminous flux at approximately | | 12 V | | 1,500 | |
| | | 12.2 V | | 1,650 | |
| | | 13.2 V | | 2,100 | |

^{9/} The viewing direction is direction A as shown in Figure 1 on sheet H9/1.

^{10/} The ends of the filament are defined as the points where, when the viewing direction is as defined in footnote 9/ above, the projection of the outside of the end turns crosses the filament axis.

^{11/} To be checked by means of a "Box system"; sheet H9/4.

^{12/} The eccentricity is measured only in viewing directions A and B as shown in Figure 1 on sheet H9/1. The points to be measured are those where the projection of the outside of the end turns nearest or furthest from the reference plane crosses the filament axis.

Screen projection requirements

This test is used to determine, by checking whether the filament is correctly positioned relative to the reference axis and reference plane, whether a filament complies with the requirements.

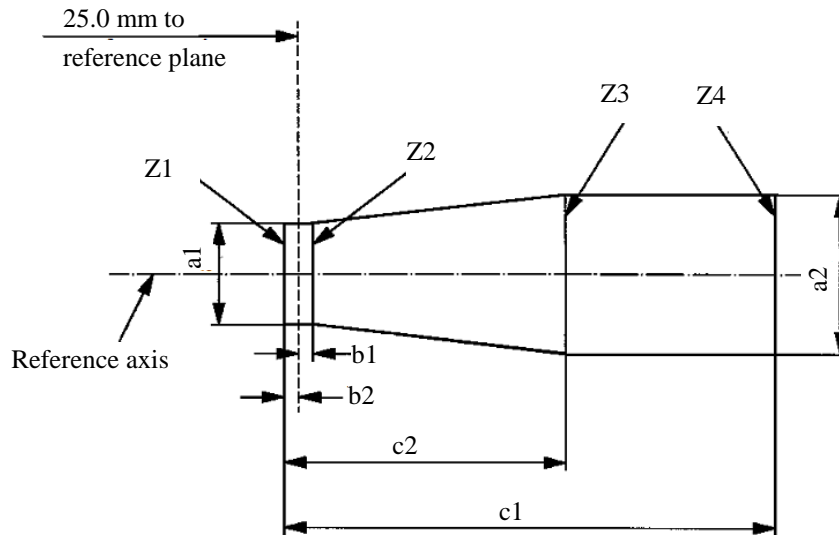

| $a1$ | $a2$ | $b1$ | $b2$ | $c1$ | $c2$ |
|-----------|-----------|------|------|------|------|
| $d + 0.4$ | $d + 0.7$ | 0.25 | | 5.7 | 4.6 |

d = diameter of filament

The filament position is checked solely in directions A and B as shown on sheet H9/1, Figure 1.

The filament shall lie entirely within the limits shown.

The ends of the filament as defined on sheet H9/3, footnote 10/, shall lie between lines Z1 and Z2 and between Z3 and Z4.

The drawings are intended only to illustrate the essential dimensions (in mm) of the filament light source

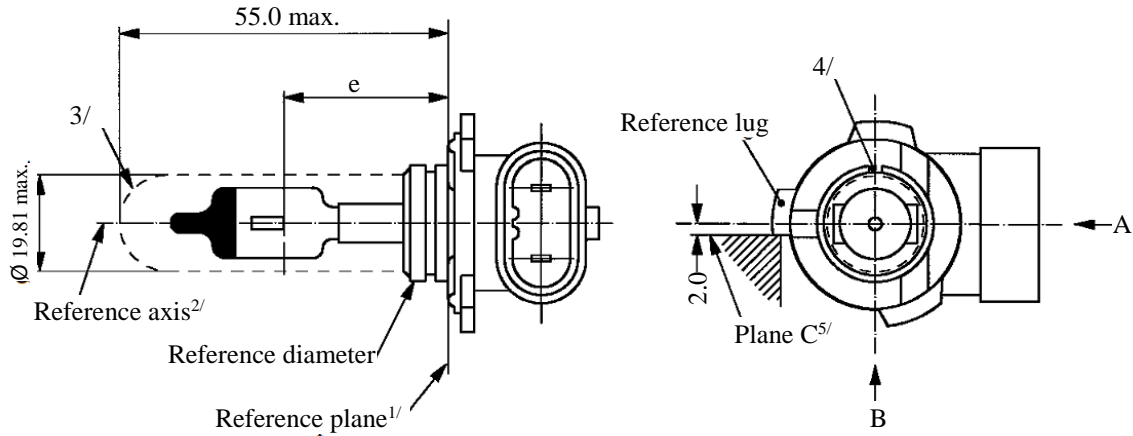

View A

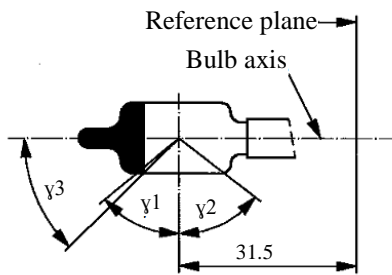

View A Distorsion free area^{6/} and black top^{7/}

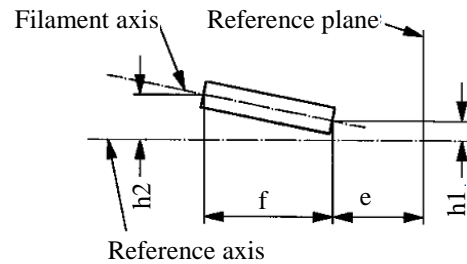

Offset filament

- ^{1/} The reference plane is the plane defined by the meeting points of cap-holder fit.
- ^{2/} The reference axis is perpendicular to the reference plane and concentric with the reference diameter of the cap.
- ^{3/} Glass bulb and supports shall not exceed the envelope and shall not interfere with insertion past the filament light source key. The envelope is concentric to the reference axis.
- ^{4/} The keyway is mandatory.
- ^{5/} The filament light source shall be rotated in the measuring holder until the reference lug contacts plane C of the holder.
- ^{6/} Glass bulb periphery shall be optically distortion-free axially and cylindrically within the angles γ_1 and γ_2 . This requirement applies to the whole bulb circumference within the angles γ_1 and γ_2 and does not need to be verified in the area covered by the obscuration.
- ^{7/} The obscuration shall extend to at least angle γ_3 and shall be at least as far as the undistorted part of the bulb defined by angle γ_1 .

Category H10

Sheet H10/2

| Dimensions in mm ^{8/} | | Tolerance | |
|--|---------------|---|--------------------------------|
| | | Filament light sources of normal production | Standard filament light source |
| e ^{9/,10/} | 28.9 | ^{11/} | ±0.16 |
| f ^{9/,10/} | 5.2 | ^{11/} | ±0.16 |
| h1, h2 | 0 | ^{11/} | ±0.15 ^{12/} |
| γ1 | 50° min. | - | - |
| γ2 | 52° min. | - | - |
| γ3 | 45° | ±5° | ±5° |
| Cap PY20d in accordance with IEC Publication 60061 (sheet 7004-31-2) | | | |
| Electrical and photometric characteristics | | | |
| Rated values | Volts | 12 | 12 |
| | Watts | 42 | 42 |
| Test voltage | Volts | 13.2 | 13.2 |
| Objective values | Watts | 50 max. | 50 max. |
| | Luminous flux | 850 ± 15 % | |
| Reference luminous flux at approximately | | 12 V | 600 |
| | | 13.2 V | 850 |

^{8/} Dimensions shall be checked with O-ring removed.

^{9/} The viewing direction is direction* B as shown in the figure on sheet H10/1.

^{10/} The ends of the filament are defined as the points where, when the viewing direction* as defined in footnote 9/ above, the projection of the outside of the end turns crosses the filament axis.

^{11/} To be checked by means of a "Box system", sheet H10/3*.

^{12/} The eccentricity is measured only in viewing directions* A and B as shown in the figure on sheet H10/1. The points to be measured are those where the projection of the outside of the end turns nearest to or furthest from the reference plane crosses the filament axis.

* Manufacturers may choose another set of perpendicular viewing directions. The viewing directions specified by the manufacturer are to be used by the testing laboratory when checking filament dimensions and position.

Screen projection requirements

This test is used to determine, by checking whether the filament is correctly positioned relative to the reference axis and reference plane, whether a filament light source complies with the requirements.

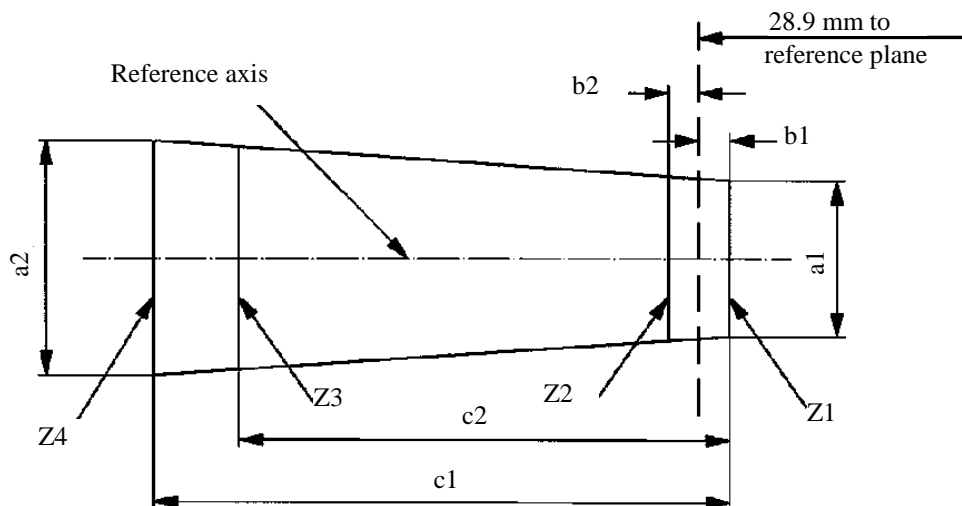

| | $a1$ | $a2$ | $b1$ | $b2$ | $c1$ | $c2$ |
|------|-------|-------|------|------|------|------|
| 12 V | 1.4 d | 1.8 d | 0.25 | | 6.1 | 4.9 |

d = diameter of filament

The filament position is checked solely in directions A and B as shown on sheet H10/1.

The filament shall lie entirely within the limits shown.

The ends of the filament as defined on sheet H10/2 footnote 10/ shall lie between lines Z1 and Z2 and between lines Z3 and Z4.

Categories H11 and H11B

Sheet H11/1

The drawings are intended only to illustrate the essential dimensions (in mm) of the filament light source

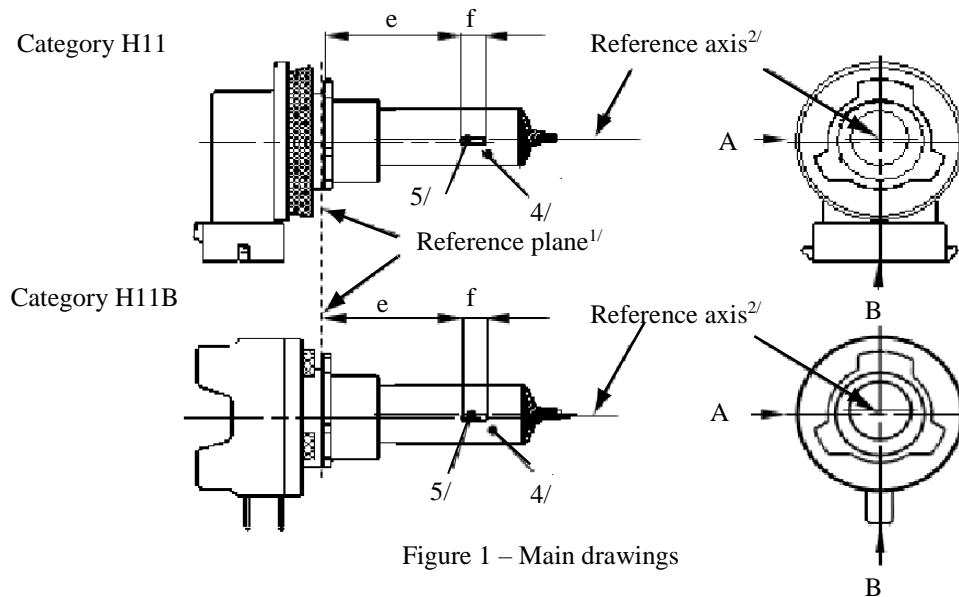
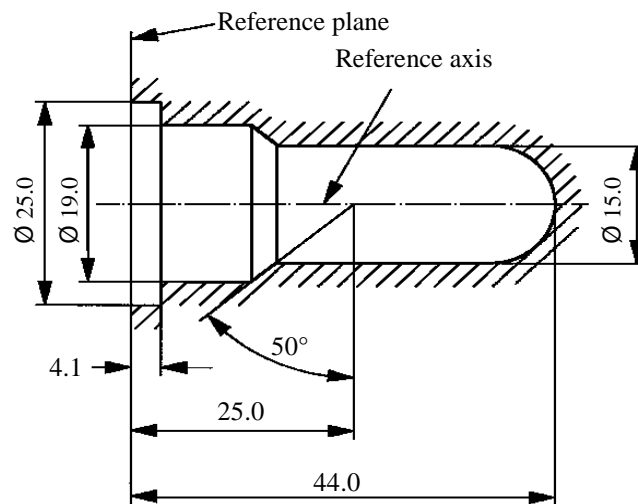

Figure 1 – Main drawings

Figure 2 - Maximum filament light source outline^{3/}

- ^{1/} The reference plane is the plane formed by the underside of the bevelled lead-in flange of the cap.
- ^{2/} The reference axis is perpendicular to the reference plane and passing through the centre of the 19 mm cap diameter.
- ^{3/} Glass bulb and supports shall not exceed the envelope as indicated in Figure 2. The envelope is concentric to the reference axis.
- ^{4/} The colour of the light emitted shall be white or selective-yellow.
- ^{5/} Notes concerning the filament diameter.
- (a) No actual diameter restrictions apply but the objective for future developments is to have $d_{max} = 1.4$ mm.
- (b) For the same manufacturer, the design diameter of standard (étalon) filament light source and filament light source of normal production shall be the same.

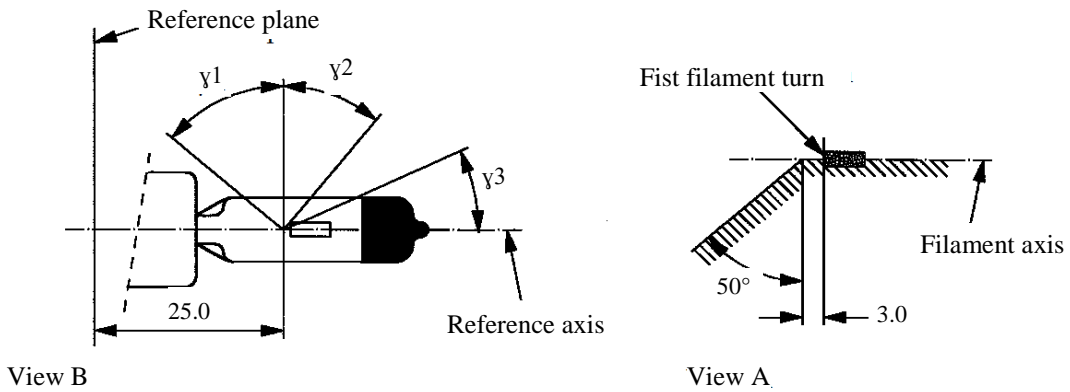

Figure 4 – Metal free zone^{8/}

Distorsion free area^{6/} and black top^{7/}

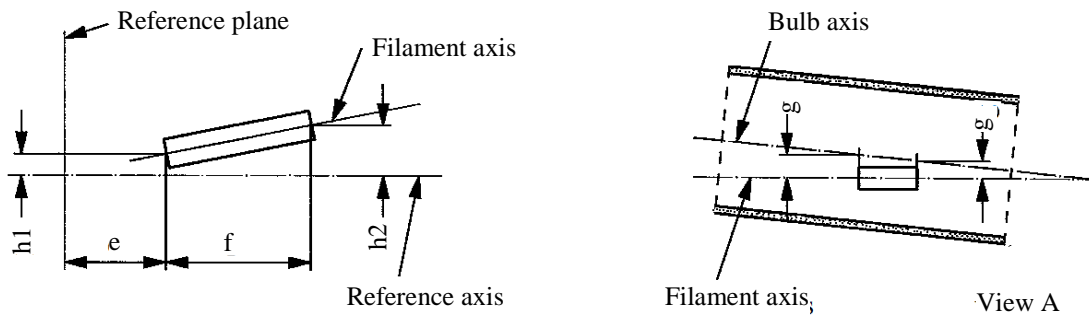

Figure 5 – Permissible offset of filament axis^{9/}
(for standard filament light sources only)

Figure 6 – Bulb eccentricity^{10/}

- ^{6/} Glass bulb shall be optically distortion free within the angles γ_1 and γ_2 . This requirement applies to the whole bulb circumference within the angles γ_1 and γ_2 .
- ^{7/} The obscuration shall extend at least to the cylindrical part of the bulb on the whole bulb top circumference. It shall, moreover, extend at least to a plane parallel to the reference plane where γ_3 crosses the outer bulb surface (view B as indicated on sheet H11/1).
- ^{8/} The internal design of the filament light source shall be such that stray light images and reflections are only located above the filament itself seen from the horizontal direction (view A as indicated in Figure 1 on sheet H11/1). No metal parts other than filament turns shall be located in the shaded area as seen in Figure 4.
- ^{9/} The offset of the filament with respect to the reference axis is measured only in viewing directions A and B as shown in Figure 1 on sheet H11/1. The points to be measured are those where the projection of the outside of the end turns nearest to or furthest from the reference plane crosses the filament axis.
- ^{10/} Eccentricity of bulb axis with respect to filament axis measured in two planes parallel to the reference plane where the projection of the outside of the end turns nearest to or furthest from the reference plane crosses the filament axis.

Categories H11 and H11B

Sheet H11/3

| Dimensions in mm | Filament light sources of normal production | | Standard filament light source | |
|--|---|--|--------------------------------|---------|
| | 12 V | 24 V | 12 V | |
| e ^{11/} | 25.0 ^{12/} | | 25.0 ± 0.1 | |
| f ^{11/} | 4.5 | 5.3 ^{12/} | 4.5 ± 0.1 | |
| g | 0.5 min. | | u.c. | |
| h1 | 0 ^{12/} | | 0 ± 0.1 | |
| h2 | 0 ^{12/} | | 0 ± 0.15 | |
| γ1 | 50° min. | | 50° min. | |
| γ2 | 40° min. | | 40° min. | |
| γ3 | 30° min. | | 30° min. | |
| Cap: | H11: PGJ19-2 H11B:PGJY19-2 | in accordance with IEC Publication 60061 (sheet 7004-110-2) in accordance with IEC Publication 60061 (sheet 7004-146-1) | | |
| Electrical and photometric characteristics | | | | |
| Rated values | Volts | 12 | 24 | 12 |
| | Watts | 55 | 70 | 55 |
| Test voltage | Volts | 13.2 | 28.0 | 13.2 |
| Objective values | Watts | 62 max. | 80 max. | 62 max. |
| | Luminous flux | 1,350 ± 10 % | 1,600 ± 10 % | |
| Reference luminous flux at approximately | | | 12 V | 1,000 |
| | | | 13.2 V | 1,350 |

^{11/} The ends of the filament are defined as the points where, when the viewing direction is View A as shown in Figure 1 on sheet H11/1, the projection of the outside of the end turns crosses the filament axis.

^{12/} To be checked by means of a "Box system"; sheet H11/4.

Screen projection requirements

This test is used to determine, by checking whether the filament is correctly positioned relative to the reference axis and reference plane, whether a filament complies with the requirements.

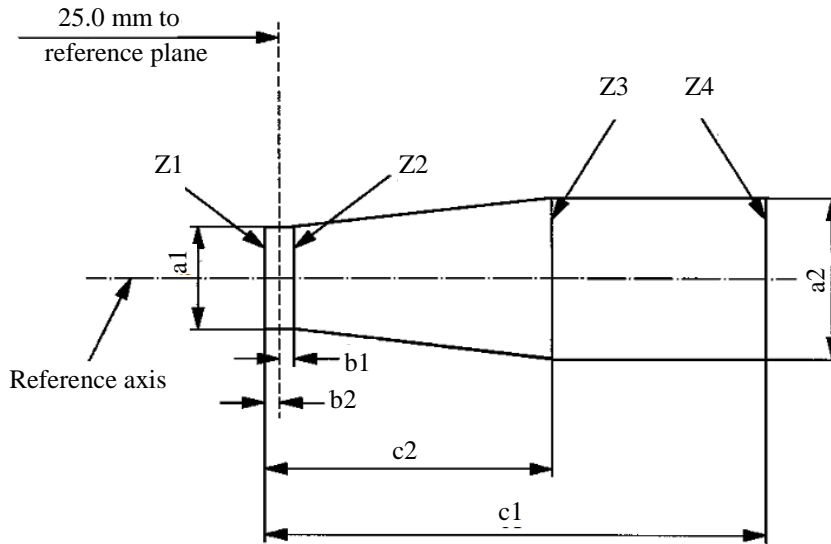

| | <i>a1</i> | <i>a2</i> | <i>b1</i> | <i>b2</i> | <i>c1</i> | <i>c2</i> |
|------|-----------|-----------|-----------|-----------|-----------|-----------|
| 12 V | $d + 0.3$ | $d + 0.5$ | 0.2 | | 5.0 | 4.0 |
| 24 V | $d + 0.6$ | $d + 1.0$ | 0.25 | | 6.3 | 4.6 |

d = diameter of filament

The filament position is checked solely in directions A and B as shown on sheet H11/1, Figure 1.

The filament shall lie entirely within the limits shown.

The ends of the filament as defined on sheet H11/3, footnote 11/, shall lie between lines Z1 and Z2 and between Z3 and Z4.

The drawings are intended only to illustrate the essential dimensions (in mm) of the filament light source

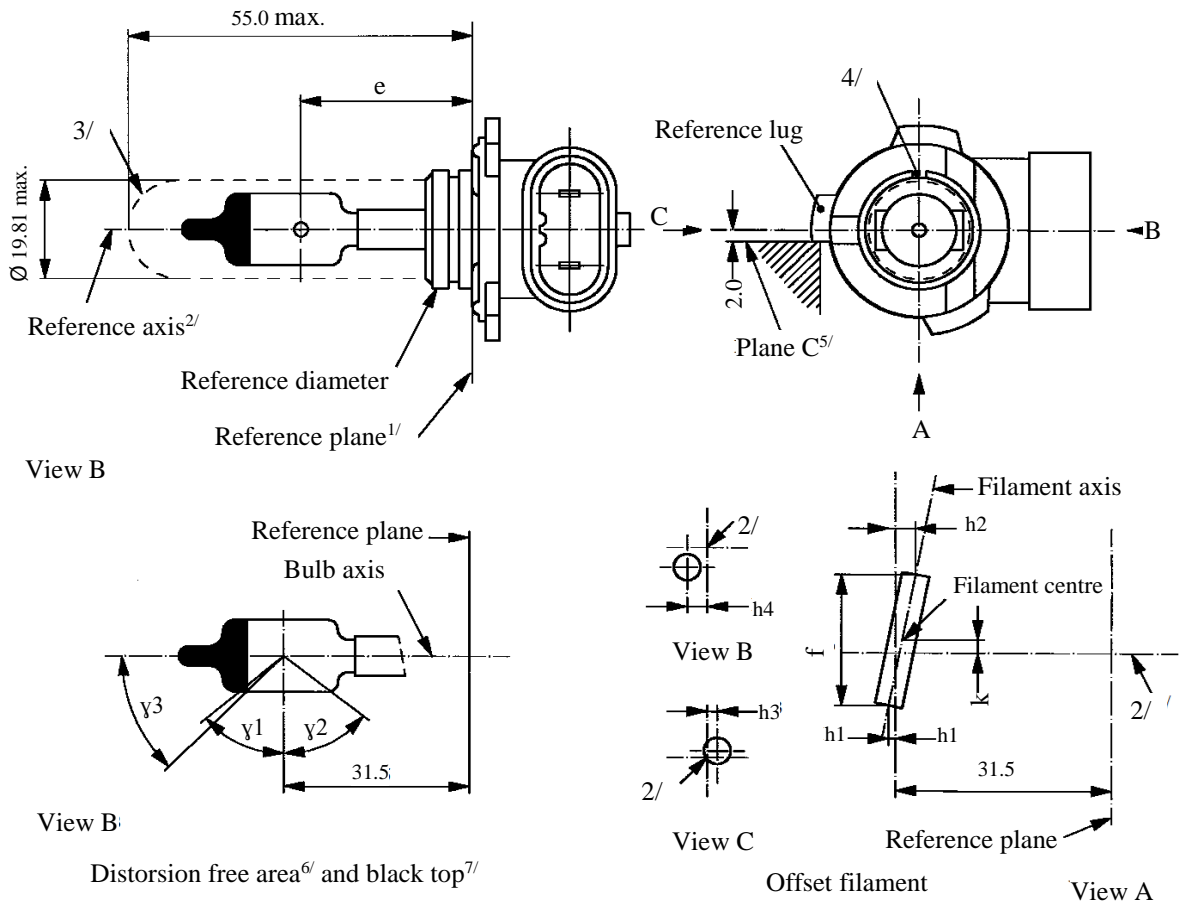

- ^{1/} The reference plane is the plane defined by the meeting points of cap-holder fit.
- ^{2/} The reference axis is perpendicular to the reference plane and concentric with the reference diameter of the cap.
- ^{3/} Glass bulb and supports shall not exceed the envelope and shall not interfere with insertion past the filament light source key. The envelope is concentric to the reference axis.
- ^{4/} The keyway is mandatory.
- ^{5/} The filament shall be rotated in the measuring holder until the reference lug contacts plane C of the holder.
- ^{6/} Glass bulb periphery shall be optically distortion-free axially and cylindrically within the angles γ_1 and γ_2 . This requirement applies to the whole bulb circumference within the angles γ_1 and γ_2 and does not need to be verified in the area covered by the obscuration.
- ^{7/} The obscuration shall extend to at least angle γ_3 and shall be at least as far as the undistorted part of the bulb defined by angle γ_1 .

| Dimensions in mm ^{8/} | | Tolerance | |
|--|---------------|---|--------------------------------|
| | | Filament light sources of normal production | Standard filament light source |
| e ^{9/,10/} | 31.5 | ^{11/} | ±0.16 |
| f ^{9/,10/} | 5.5 | 4.8 min | ±0.16 |
| h1, h2, h3, h4 | 0 | ^{11/} | ±0.15 ^{12/} |
| k | 0 | ^{11/} | ±0.15 ^{13/} |
| γ1 | 50° min. | - | - |
| γ2 | 52° min. | - | - |
| γ3 | 45° | ±5° | ±5° |
| Cap PZ20d in accordance with IEC Publication 60061 (sheet 7004-31-2) | | | |
| Electrical and photometric characteristics | | | |
| Rated values | Volts | 12 | 12 |
| | Watts | 53 | 53 |
| Test voltage | Volts | 13.2 | 13.2 |
| Objective values | Watts | 61 max. | 61 max. |
| | Luminous flux | 1,050 ± 15 % | |
| Reference luminous flux at approximately | | 12 V | 775 |
| | | 13.2 V | 1,050 |

^{8/} Dimensions shall be checked with O-ring removed.

^{9/} The viewing direction is direction A as shown in the figure on sheet H12/1.

^{10/} The ends of the filament are defined as the points where, when the viewing direction as defined in footnote 9/ above, the projection of the outside of the end turns crosses the filament axis.

^{11/} To be checked by means of a "Box system"; sheet H12/3.

^{12/} Dimensions h1 and h2 are measured in viewing direction A, dimension h3 in direction C and dimension h4 in direction B as shown in the figure on sheet H12/1. The points to be measured are those where the projection of the outside of the end turns nearest to or furthest from the reference plane crosses the filament axis.

^{13/} Dimension k is measured only in viewing direction A.

Screen projection requirements

This test is used to determine, by checking whether the filament is correctly positioned relative to the reference axis and reference plane, whether a filament light source complies with the requirements.

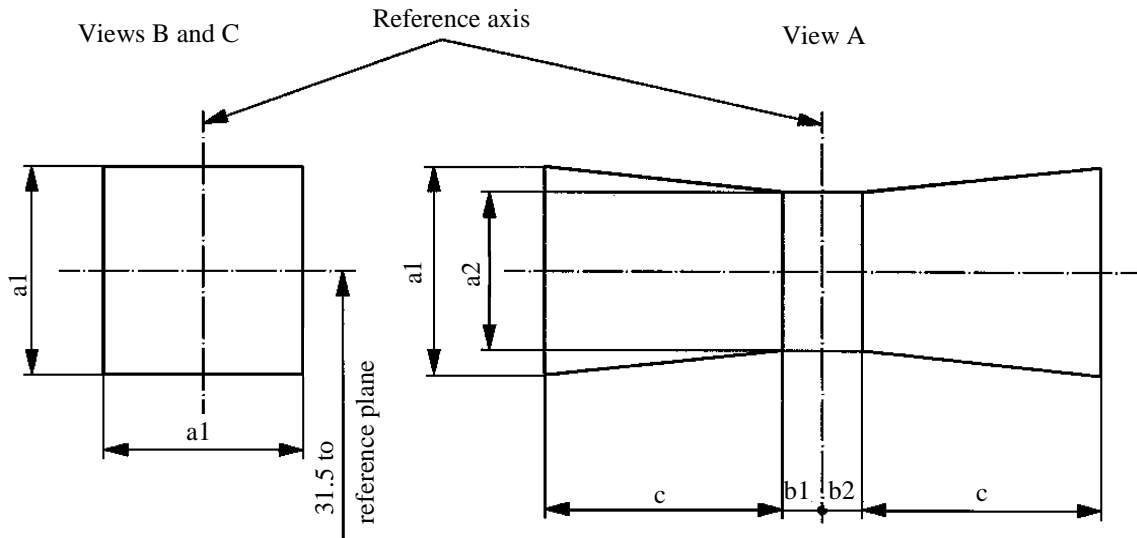

| a_1 | a_2 | b_1 | b_2 | c |
|-------|-------|-------|-------|-----|
| 1.6 d | 1.3 d | 0.30 | 0.30 | 2.8 |

d = diameter of filament

For the directions of view A, B and C, see sheet H12/1.

The filament shall lie entirely within the limits shown.

The centre the filament shall lie between the limits of dimensions b_1 and b_2 .

The drawings are intended only to illustrate the essential dimensions (in mm) of the filament light source.

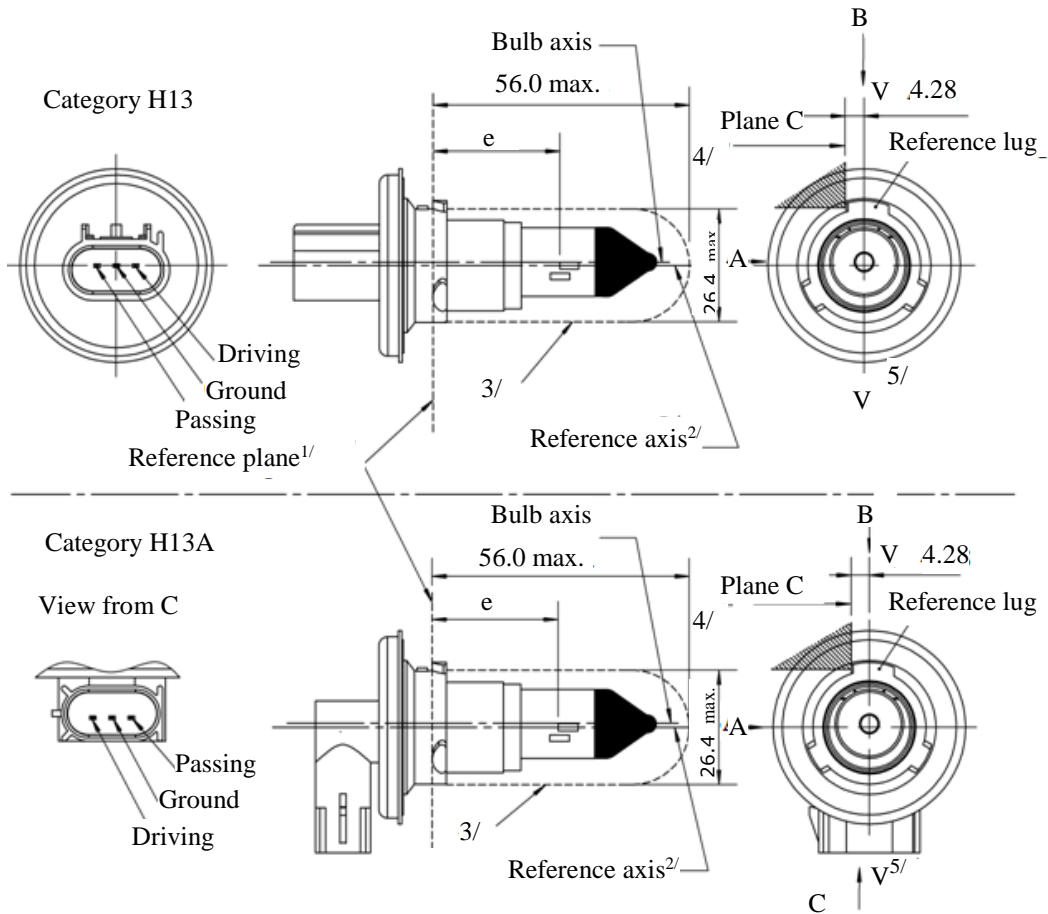

Figure 1 - Main drawing

- 1/ The reference plane is the plane formed by the underside of the three radiused tabs of the cap.
- 2/ The reference axis is perpendicular to the reference plane and crosses the intersection of the two perpendiculars as indicated in Figure 2 on sheet H13/2.
- 3/ Glass bulb and supports shall not exceed the envelope as indicated. The envelope is concentric to the reference axis.
- 4/ The filament light source shall be rotated in the measuring holder until the reference lug contacts plane C of the holder.
- 5/ Plane V-V is the plane perpendicular to the reference plane passing through the reference axis and parallel to plane C.

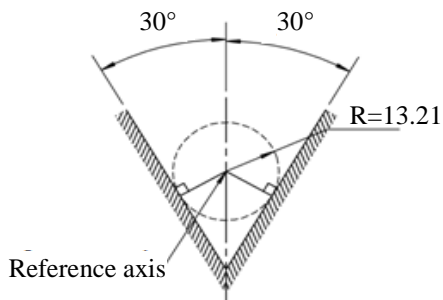

Figure 2 – Definition of reference axis^{2/}

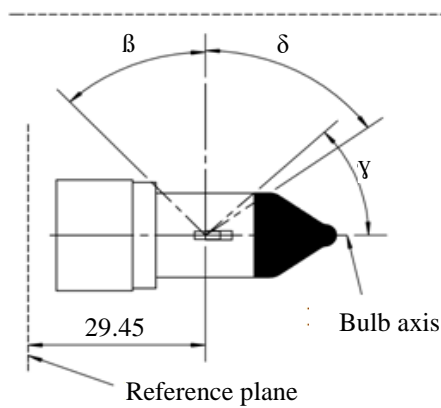

Figure 3 – Undistorted area^{6/} and opaque coating^{7/}

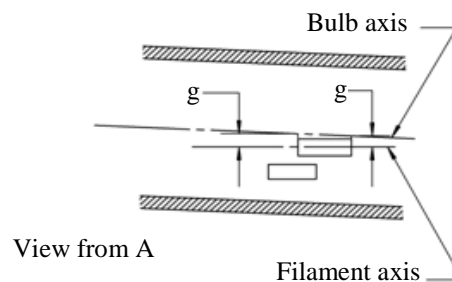
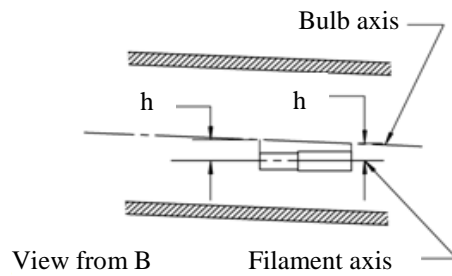

Figure 4 – Bulb offset^{8/}

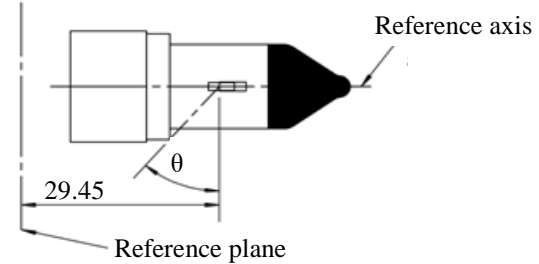

Figure 5 – Light blocking toward cap^{9/}

- ^{6/} Glass bulb shall be optically distortion-free axially and cylindrically within the angles β and δ . This requirement applies to the whole bulb circumference within the angles β and δ and does not need to be verified in the area covered by the opaque coating.
- ^{7/} The opaque coating shall extend at least to the cylindrical part of the bulb on the whole bulb top circumference. It shall moreover extend at least to a plane parallel to the reference plane where γ crosses the outer bulb surface (view B as indicated on sheet H13/1).
- ^{8/} Offset of passing-beam filament in relation to the bulb axis is measured in two planes parallel to the reference plane where the projection of the outside end turns nearest to and farthest from the reference plane crosses the passing-beam filament axis.
- ^{9/} Light shall be blocked over the cap end of the bulb extending to angle θ . This requirement applies in all directions around the reference axis.

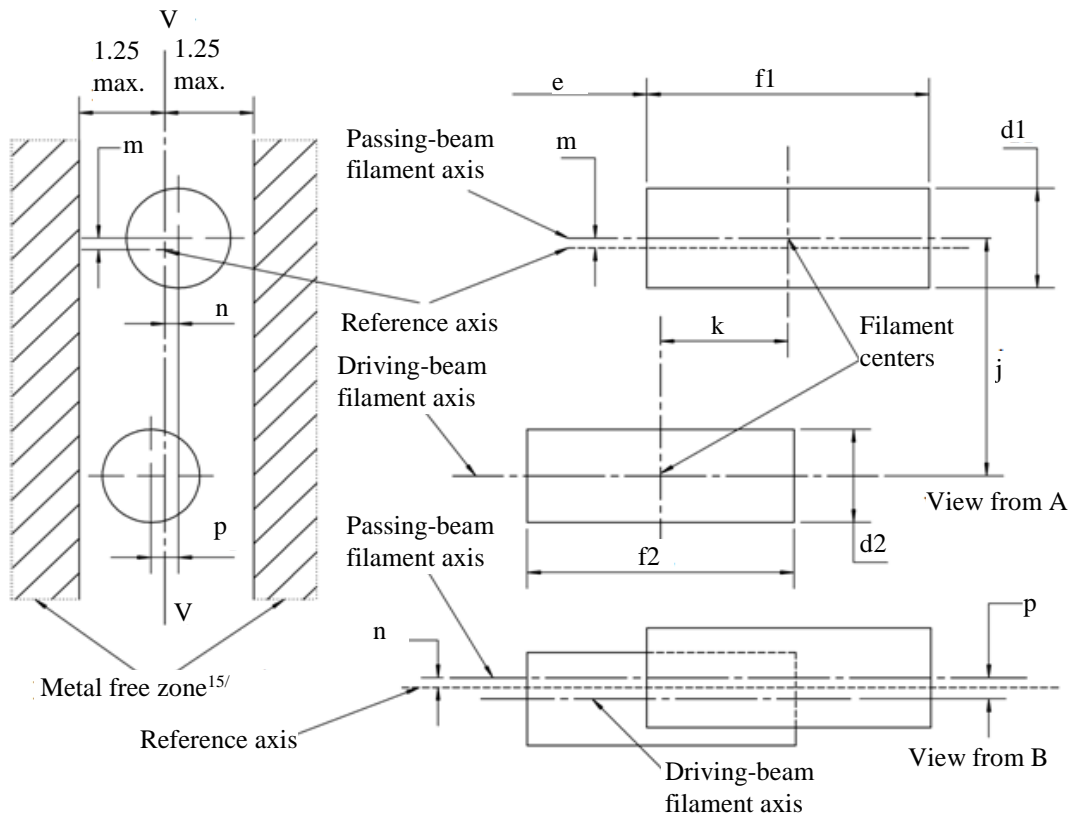

Figure 6 – Position and dimensions of filaments ^{10/, 11/, 12/, 13/, 14/}

- ^{10/} Dimensions j , k and p are measured from the centre of the passing-beam filament to the centre of the driving-beam filament.
- ^{11/} Dimensions m and n are measured from the reference axis to the centre of the passing-beam filament.
- ^{12/} Both filaments axis are to be held within a 2° tilt with respect to the reference axis about the centre of the respective filament.
- ^{13/} Note concerning the filament diameters.
(a) For the same manufacturer, the design filament diameter of standard (étalon) filament light source and filament light source of normal production shall be the same.
- ^{14/} For both the driving-beam and the passing-beam filament distortion shall not exceed ± 5 per cent of filament diameter from a cylinder.
- ^{15/} The metal free zone limits the location of lead wires within the optical path. No metal parts shall be located in the shaded area as seen in Figure 6.

Categories H13 and H13A

Sheet H13/4

| Dimensions in mm | | Tolerance | | | |
|---|------------------------------|---|--------------|--------------------------------|---------|
| | | Filament light sources of normal production | | Standard filament light source | |
| d1 ^{13/, 17/} | 1.8 max. | - | | - | |
| d2 ^{13/, 17/} | 1.8 max. | - | | - | |
| e ^{16/} | 29.45 | ±0.20 | | ±0.10 | |
| f 1 ^{16/} | 4.6 | ±0.50 | | ±0.25 | |
| f 2 ^{16/} | 4.6 | ±0.50 | | ±0.25 | |
| g ^{8/, 17/} | 0.5 d1 | ±0.40 | | ±0.20 | |
| h ^{8/} | 0 | ±0.30 | | ±0.15 | |
| j ^{10/} | 2.5 | ±0.20 | | ±0.10 | |
| k ^{10/} | 2.0 | ±0.20 | | ±0.10 | |
| m ^{10/} | 0 | ±0.20 | | ±0.13 | |
| n ^{10/} | 0 | ±0.20 | | ±0.13 | |
| p ^{10/} | 0 | ±0.08 | | ±0.08 | |
| β | 42° min. | - | | - | |
| δ | 52° min. | - | | - | |
| γ | 43° | +0° / -5° | | +0° / -5° | |
| θ ^{9/} | 41° | ±4° | | ±4° | |
| Cap: | H13: P26.4t H13A: PJ26.4t | in accordance with IEC Publication 60061 (sheet 7004-128-3) | | | |
| Electrical and photometric characteristics ^{18/} | | | | | |
| Rated values | Volts | 12 | | 12 | |
| | Watts | 55 | 60 | 55 | 60 |
| Test voltage | Volts | 13.2 | | 13.2 | |
| Objective values | Watts | 68 max. | 75 max. | 68 max. | 75 max. |
| | Luminous flux | 1,100 ± 15 % | 1,700 ± 15 % | | |
| Reference luminous flux at approximately | | | 12 V | 800 | 1,200 |
| | | | 13.2 V | 1,100 | 1,700 |

^{16/} The ends of the filament are defined as the points where, when the viewing direction is direction A as shown on sheet H13/1, the projection of the outside of the end turns crosses the filament axis.

^{17/} d1 is the actual diameter of the passing-beam filament. d2 is the actual diameter of the driving-beam filament.

^{18/} The values indicated in the left-hand columns relate to the passing-beam filament and those indicated in the right-hand columns to the driving-beam filament.

The drawings are intended only to illustrate the essential dimensions (in mm) of the filament light source.

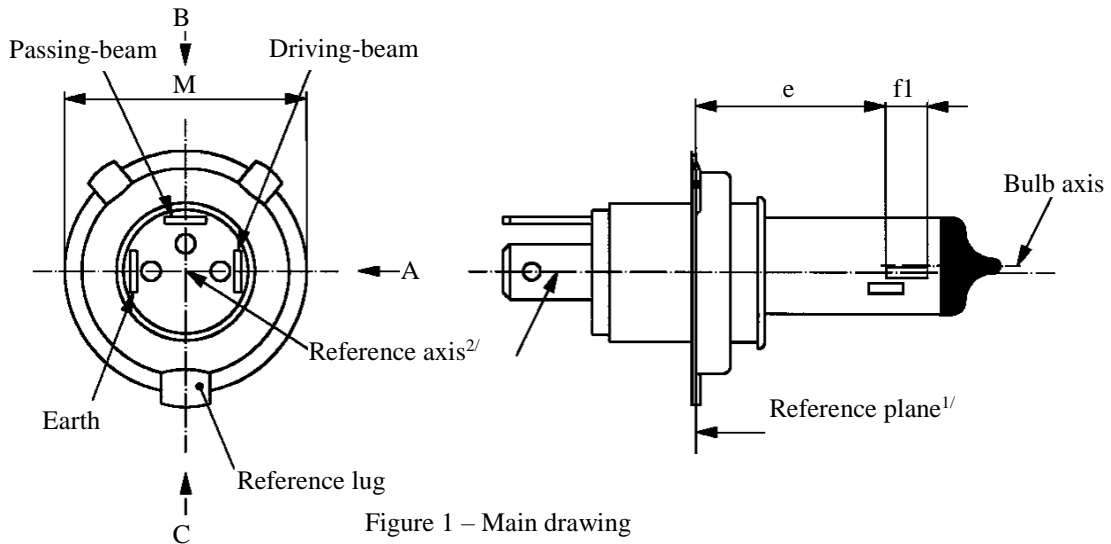

Figure 1 – Main drawing
reference plane

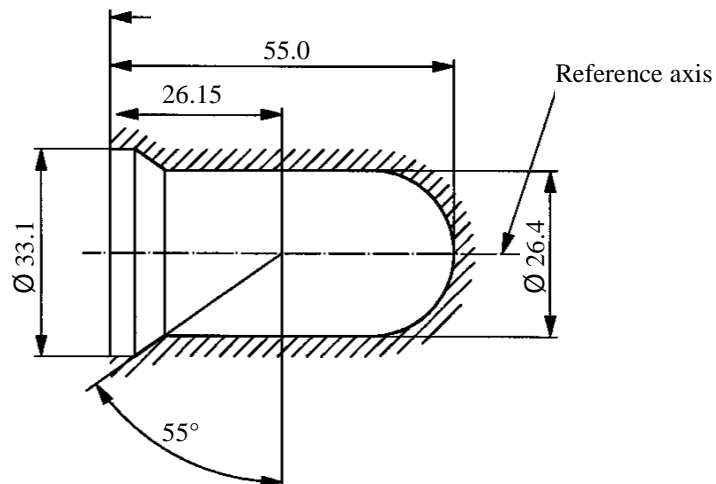
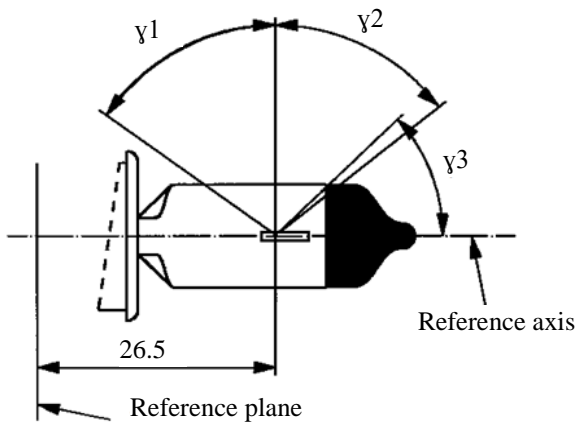

Figure 2 – Maximum filament light source outline^{3/}

- ^{1/} The reference plane is defined by the points on the surface of the holder on which the three lugs of the cap ring will rest.
- ^{2/} The reference axis is perpendicular to the reference plane and passing through the centre of the cap ring diameter "M"
- ^{3/} Glass bulb and supports shall not exceed the envelope as indicated in Figure 2. The envelope is concentric to the reference axis.



View B

Figure 3 – Distorsion free area^{4/} and black top^{5/}

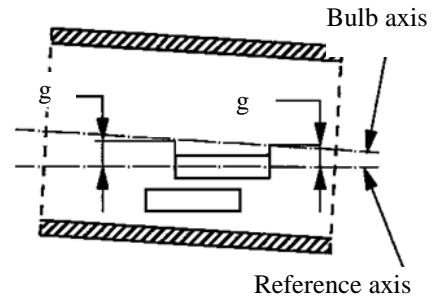

View A

Figure 4 – Bulb eccentricity^{6/}

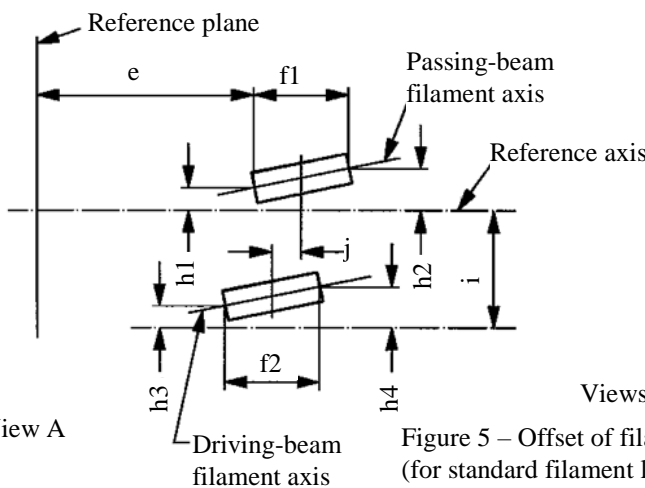

View A

Figure 5 – Offset of filament axis^{7/}
(for standard filament light sources only)

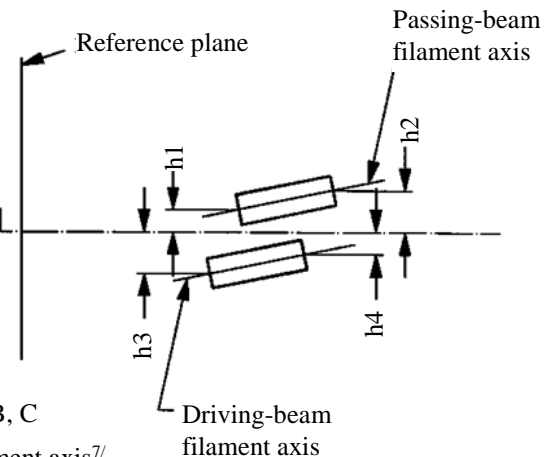

Views B, C

^{4/} Glass bulb shall be optically distortion free within the angles γ_1 and γ_2 . This requirement applies to the whole bulb circumference within the angles γ_1 and γ_2 and does not need to be verified in the area covered by the obscuration.

^{5/} The obscuration shall extend at least to the cylindrical part of the bulb on the whole bulb top circumference. It shall, moreover, extend at least to a plane parallel to the reference plane where γ_3 crosses the outer bulb surface (view B as indicated on sheet H14/1).

^{6/} Eccentricity of bulb with respect to passing-beam filament axis is measured in two planes parallel to the reference plane where the projection of the outside of the end turns nearest to or furthest from the reference plane crosses the passing-beam filament axis.

^{7/} The offset of the filaments with respect to the reference axis is measured only in viewing direction A, B and C as shown in Figure 1 on sheet H14/1. The points to be measured are those where the projection of the outside of the end turns nearest to or furthest from the reference plane crosses the filaments axis.

| Dimensions in mm | | Filament light source of normal production | | Standard filament light sources | |
|--|---------------|--|--------------|---------------------------------|---------|
| e ^{8/} | 26.15 | 10 [/] | | ±0.1 | |
| f1 ^{8/,9/} | 5.3 | 10 [/] | | ±0.1 | |
| f2 ^{8/,9/} | 5.0 | 10 [/] | | ±0.1 | |
| g | 0.3 min. | | | | |
| h1 | 0 | 10 [/] | | ±0.1 | |
| h2 | 0 | 10 [/] | | ±0.15 | |
| h3 | 0 | 10 [/] | | ±0.15 | |
| h4 | 0 | 10 [/] | | ±0.15 | |
| i | 2.7 | | | - | |
| j | 2.5 | 10 [/] | | ±0.1 | |
| γ1 | 55° min. | - | | - | |
| γ2 | 52° min. | - | | - | |
| γ3 | 43° | 0/-5° | | 0/-5° | |
| Cap P38t in accordance with IEC Publication 60061 (sheet 7004-133-1) | | | | | |
| Electrical and photometric characteristics | | | | | |
| Rated values | Volts | 12 | | 12 | |
| | Watts | 55 | 60 | 55 | 60 |
| Test voltage | Volts | 13.2 | | 13.2 | |
| Objective values | Watts | 68 max. | 75 max. | 68 max. | 75 max. |
| | Luminous flux | 1,150 ± 15 % | 1,750 ± 15 % | | |
| Reference luminous flux at approximately | | | 12 V | 860 | 1,300 |
| | | | 13.2 V | 1,150 | 1,750 |

^{8/} The ends of the filaments are defined as the points where, when the viewing direction is direction A as shown in Figure 1 on sheet H14/1, the projection of the outside of the end turns crosses the filaments axis.

^{9/} "f1" represents the length of the passing-beam filament and "f2" represents the length of the driving-beam filament.

^{10/} To be checked by means of a "Box system"; sheet H14/4.

Screen projection requirements

This test is used to determine, by checking whether the filaments are correctly positioned relative to the reference axis and the reference plane, whether a filament light source complies with the requirements.

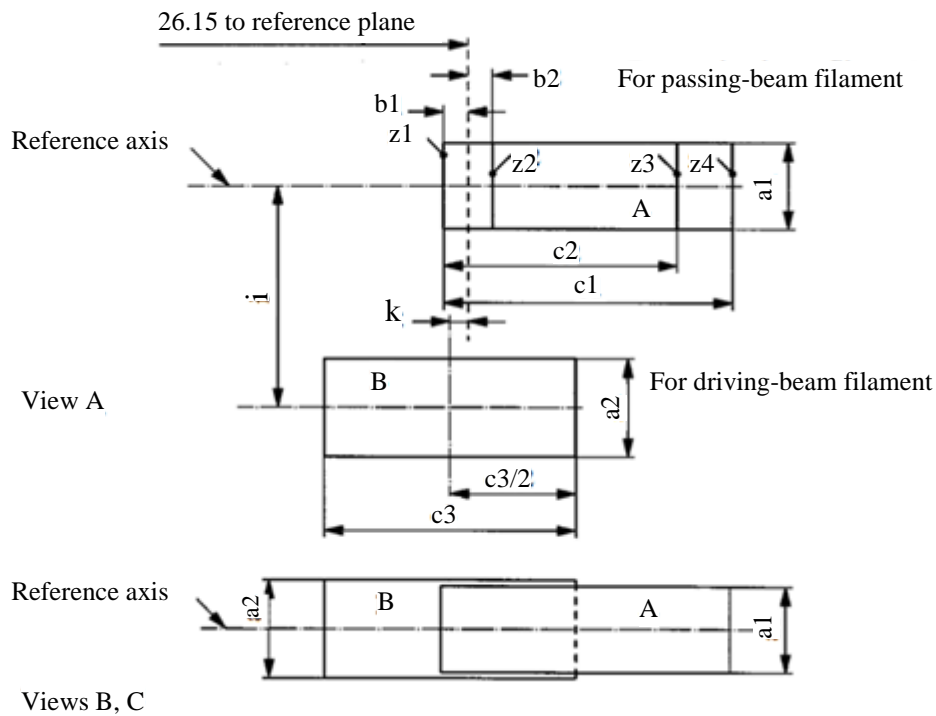

| <i>a1</i> | <i>a2</i> | <i>b1</i> | <i>b2</i> | <i>c1</i> | <i>c2</i> | <i>c3</i> | <i>i</i> | <i>k</i> |
|------------|------------|-----------|-----------|-----------|-----------|-----------|----------|----------|
| $d1 + 0.5$ | $1.6 * d2$ | 0.2 | 0.2 | 5.8 | 5.1 | 5.75 | 2.7 | 0.15 |

d1 is diameter of the passing-beam filament and *d2* that of the driving-beam filament.

Notes concerning the filaments diameter:

- (a) No actual diameter restrictions apply but the objective for future developments is to have *d1* max. = 1.6 mm and *d2* max. = 1.6 mm.
- (b) For the same manufacture, the design diameter of standard filament light sources and filament light sources of normal production shall be the same.

The positions of the filaments are checked solely in directions A, B and C as shown in Figure 1 on sheet H14/1.

The passing-beam filament shall lie entirely in the rectangle A and the driving-beam filament entirely in rectangle B.

The ends of the passing-beam filament as defined on sheet H14/3, footnote 8/ shall lie between lines Z1 and Z2 and between lines Z3 and Z4.

The drawings are intended only to illustrate the essential dimensions (in mm) of the filament light source

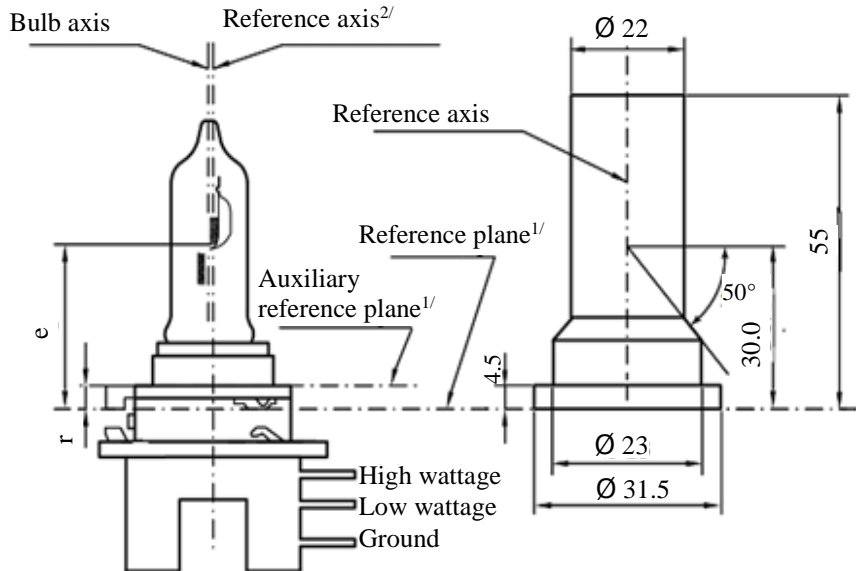

Figure 1 – Main drawing

Figure 3 - Maximum filament light source outlines^{3/}

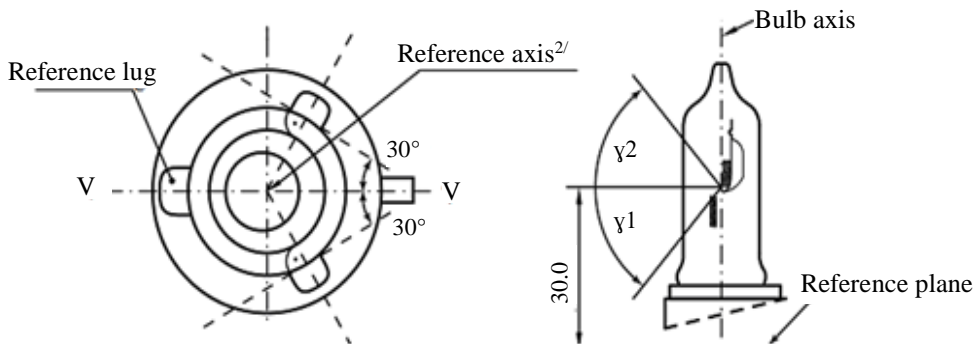

Figure 2 – Definition of reference axis^{7/}

Figure 4 - Distorsion free area^{4/}

- ^{1/} The reference plane is defined by the points at which the holder touches the three lugs of the cap ring from the plug side. It is intended for use as an internal reference plane.
The auxiliary reference plane is defined by the points on the surface of the holder on which the three supporting bosses of the cap ring will rest. It is intended for use as an external reference plane.
The cap is designed for use of the (internal) reference plane, but for certain applications the (external) auxiliary reference plane may be used instead.
- ^{2/} The reference axis is perpendicular to the reference plane and crosses the intersection of the two perpendiculars as indicated in Figure 2 on sheet H15/1.
- ^{3/} Glass bulb and supports shall not exceed the envelope as indicated in Figure 3. The envelope is concentric to the reference axis.
- ^{4/} Glass bulb shall be optically distortion free within the angles γ_1 and γ_2 as indicated in Figure 4. This requirement applies to the whole bulb circumference within the angles γ_1 and γ_2 .

Category H15

Sheet H15/2

| <i>Dimensions in mm</i> | <i>Filament light sources of normal production</i> | | | | <i>Standard filament light source</i> | | |
|--|--|------------------|---------------------|------------------|---------------------------------------|------------------|---------|
| | <i>12 V</i> | | <i>24 V</i> | | <i>12 V</i> | | |
| e | 30.0 + 0.35 / -0.25 | | 30.0 + 0.35 / -0.25 | | 30.0 + 0.20 / -0.15 | | |
| γ_1 | 50°min | | 50°min | | 50°min | | |
| γ_2 | 50°min | | 50°min | | 50°min | | |
| r | For details see cap sheet | | | | | | |
| Cap PGJ23t-1 in accordance with IEC Publication 60061 (sheet 7004-155-1) | | | | | | | |
| Electrical and photometric characteristics | | | | | | | |
| Rated values | Volts | 12 ^{5/} | | 24 ^{5/} | | 12 ^{5/} | |
| | Watts | 15 | 55 | 20 | 60 | 15 | 55 |
| Test voltage | Volts | 13.2 | | 28.0 | | 13.2 | 13.2 |
| Objective values | Watts | 19 max. | 64 max. | 24 max. | 73 max. | 19 max. | 64 max. |
| | Luminous flux | 260 | 1,350 | 300 | 1,500 | | |
| | | ±10 % | | | | | |
| Reference luminous flux at approximately 12 V | | | | | | 1,000 | |
| Reference luminous flux at approximately 13.2 V | | | | | | 1,350 | |
| Reference luminous flux at approximately 13.5 V | | | | | 290 | | |

^{5/} The values indicated in the left-hand columns relate to the low wattage filament. Those indicated in the right-hand columns relate to the high wattage filament.

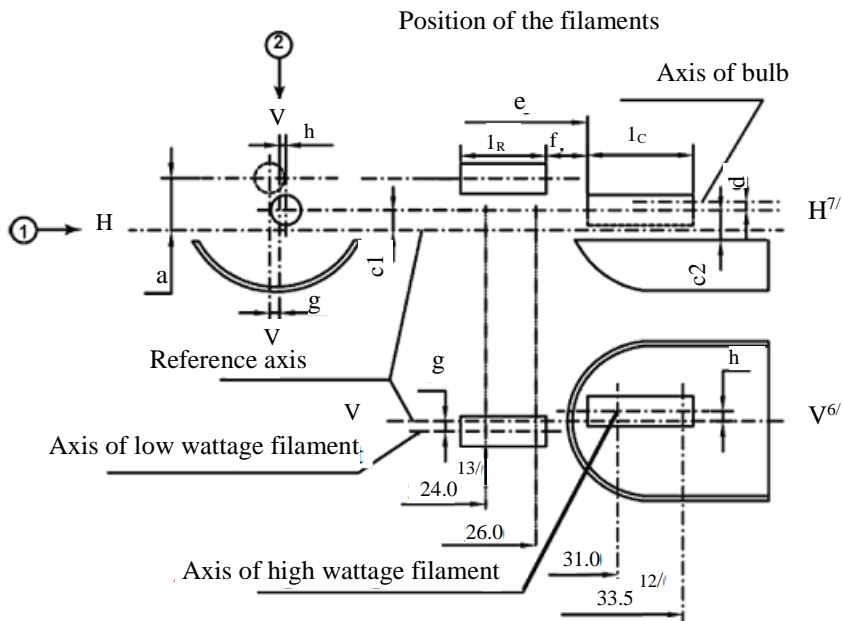
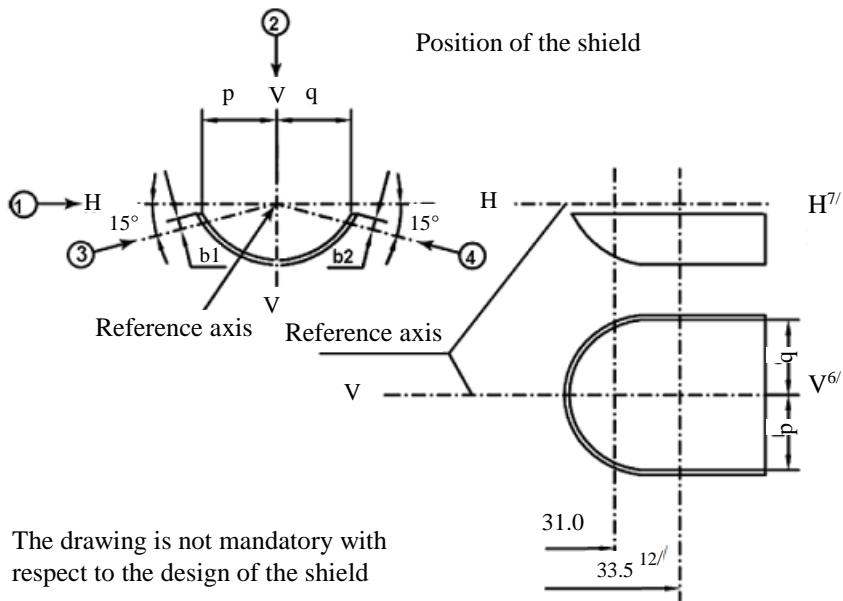

Category H15

Sheet H15/4

Table of the dimensions (in mm) referred to in the drawings on sheet H15/3

| Reference* | | Dimension** | | Tolerance | | | |
|-----------------------------------|---------|------------------------------------|--------|---|-------|--------------------------------|----------------|
| | | | | Filament light sources of normal production | | Standard filament light source | |
| 12 V | 24 V | 12 V | 24 V | 12 V | 24 V | 12 V | 24 V |
| a/24.0 | a/24.5 | 1.8 | | ±0.35 | | ±0.20 | |
| a/26.0 | | 1.8 | | ±0.35 | | ±0.20 | |
| b1/31.0 | | 0 | | ±0.30 | | ±0.15 | |
| b1/33.5 | b1/34.0 | b1/31.0 mv | | ±0.30 | | ±0.15 | |
| b2/31.0 | | 0 | | ±0.30 | | ±0.15 | |
| b2/33.5 | b2/34.0 | b2/31.0 mv | | ±0.30 | | ±0.15 | |
| c1/31.0 | | 0 | | ±0.30 | ±0.50 | ±0.15 | ±0.25 |
| c1/33.5 | c1/34.0 | c1/31.0 mv | | ±0.30 | ±0.50 | ±0.15 | ±0.25 |
| c2/33.5 | c2/34.0 | 1.1 | | ±0.30 | ±0.50 | ±0.15 | ±0.25 |
| d | | min. 0.1 | | - | | - | |
| f ^{8/, 9/, 10/} | | 2.7 | | ±0.30 | ±0.40 | +0.20 -0.10 | +0.25 -0.15 |
| g/24.0 | g/24.5 | 0 | | ±0.50 | ±0.70 | ±0.25 | ±0.35 |
| g/26.0 | | 0 | | ±0.50 | ±0.70 | ±0.25 | ±0.35 |
| h/31.0 | | 0 | | ±0.50 | ±0.60 | ±0.25 | ±0.30 |
| h/33.5 | h/34.0 | h/31.0 mv | | ±0.30 | ±0.40 | ±0.15 | ±0.20 |
| 1 _R ^{8/, 11/} | | 4.2 | 4.6 | ±0.40 | ±0.60 | ±0.20 | ±0.30 |
| 1 _C ^{8/, 9/} | | 4.4 | 5.4 | ±0.40 | ±0.60 | ±0.20 | ±0.30 |
| p/33.5 | p/34.0 | Depends on the shape of the shield | | - | | - | |
| q/33.5 | q/34.0 | p/33.5 | p/34.0 | ±1.20 | | ±0.60 | |

* ".../26.0" means dimension to be measured at the distance from the reference plane indicated in mm after the stroke.

** "31.0 mv" means the value measured at a distance of 31.0 mm from the reference plane.

- ^{6/} Plane V-V is the plane perpendicular to the reference plane and passing through the reference axis and through the axis of the reference lug.
- ^{7/} Plane H-H is the plane perpendicular to both the reference plane and plane V-V and passing through the reference axis.
- ^{8/} The end turns of the filament are defined as being the first luminous turn and the last luminous turn that are at substantially the correct helix angle.
- ^{9/} For the high wattage filament, the points to be measured are the intersections, seen in direction 1, of the lateral edge of the shield with the outside of the end turns defined under footnote 8/.
- ^{10/} "e" denotes the distance from the reference plane to the beginning of the driving-beam filament as defined above.
- ^{11/} For the low wattage filament the points to be measured are the intersections, seen in direction 1, of a plane, parallel to plane H-H and situated at a distance of 1.8 mm above it, with the end turns defined under footnote 8/.
- ^{12/} 34.0 for the 24 V type.
- ^{13/} 24.5 for the 24 V type.

Additional explanations to sheet H15/3

The dimensions below are measured in four directions:

- 1) For dimensions a, c1, c2, d, e, f, IR and IC;
- 2) For dimensions g, h, p and q;
- 3) For dimension b1;
- 4) For dimension b2.

Dimensions b1, b2, c1 and h are measured in planes parallel to the reference plane at distances of 31.0 mm and 33.5 mm (34.0 mm for 24 V types).

Dimensions c2, p and q are measured in a plane parallel to the reference plane at a distance of 33.5 mm (34.0 mm for 24 V types).

Dimensions a and g are measured in planes parallel to the reference plane at distances of 24.0 mm (24.5 mm for 24 V types) and 26.0 mm.

Categories H16 and H16B

Sheet H16/1

The drawings are intended only to illustrate the essential dimensions (in mm) of the filament light source

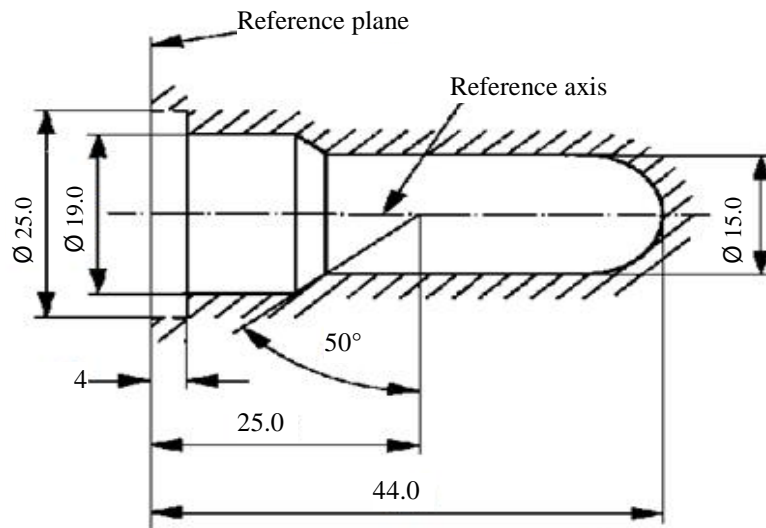
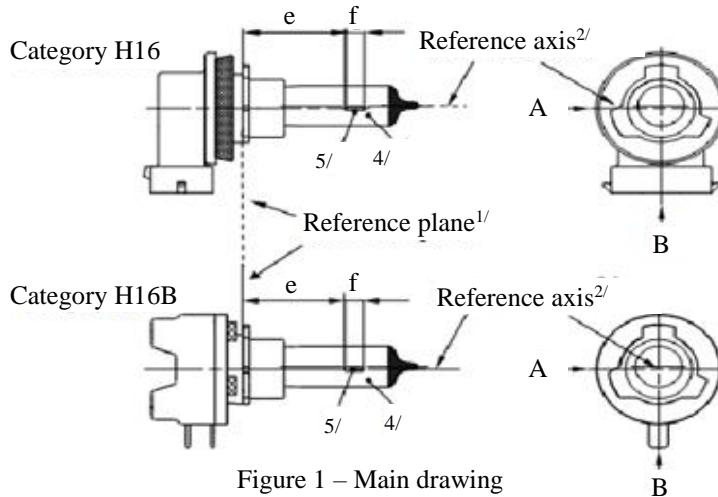

- ^{1/} The reference plane is the plane formed by the underside of the bevelled lead-in flange of the cap.
- ^{2/} The reference axis is perpendicular to the reference plane and passing through the centre of the 19 mm cap diameter.
- ^{3/} Glass bulb and supports shall not exceed the envelope as indicated in Figure 2. The envelope is concentric to the reference axis.
- ^{4/} The light emitted shall be white or selective yellow.
- ^{5/} Notes concerning the filament diameter.
- (a) No actual diameter restrictions apply but the objective for future developments is to have $d_{max.} = 1.1$ mm.
- (b) For the same manufacturer, the design diameter of standard (étalon) filament light source and filament light source of normal production shall be the same.

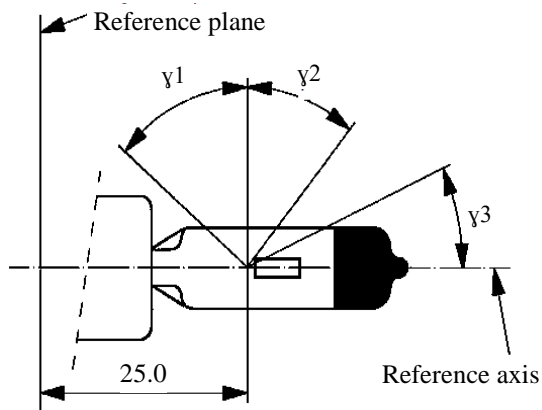

View B

Figure 3 - Distorsion free area^{6/} and black top^{7/}

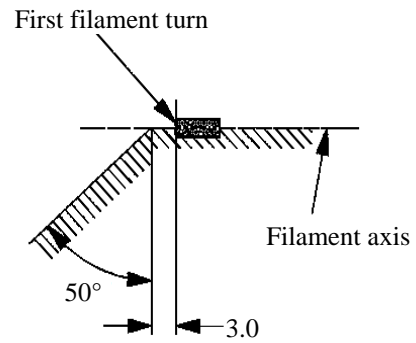

View A

Figure 4 – Metal free zone^{8/}

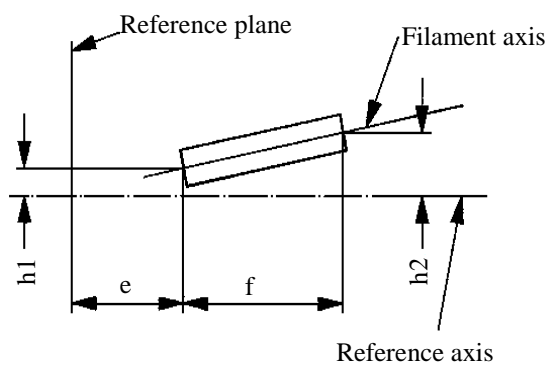

Figure 5 – Permissible offset of filament axis^{9/}
(for standard filament light sources only)

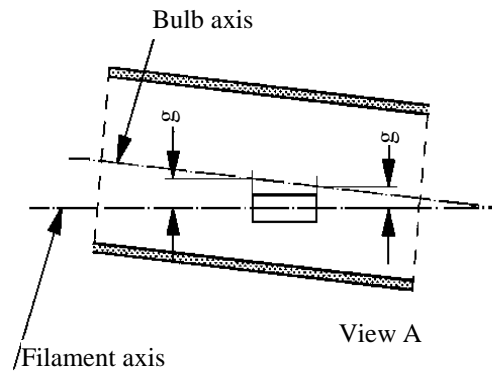

Figure 6 – Bulb eccentricity^{10/}

- ^{6/} Glass bulb shall be optically distortion free within the angles γ_1 and γ_2 . This requirement applies to the whole bulb circumference within the angles γ_1 and γ_2 .
- ^{7/} The obscuration shall extend at least to angle γ_3 and shall extend at least to the cylindrical part of the bulb on the whole bulb top circumference.
- ^{8/} The internal design of the filament light source shall be such that stray light images and reflections are only located above the filament itself seen from the horizontal direction. (View A as indicated in Figure 1 on sheet H16/1). No metal parts other than filament turns shall be located in the shaded area as seen in Figure 4.
- ^{9/} The offset of the filament with respect to the reference axis is measured only in viewing directions A and B as shown in Figure 1 in sheet H16/1. The points to be measured are those where the projection of the outside of the end turns nearest to or furthest from the reference plane crosses the filament axis.
- ^{10/} Offset of filament in relation to bulb axis measured in two planes parallel to the reference plane where the projection of the outside of the end turns nearest to or furthest from the reference plane crosses the filament axis.

Categories H16 and H16B

Sheet H16/3

| <i>Dimensions in mm</i> | <i>Filament light sources of normal production</i> | | <i>Standard filament light source</i> |
|---|--|---|---------------------------------------|
| | 12 V | | 12 V |
| e ^{11/} | 25.0 ^{12/} | | 25.0 ± 0.1 |
| f ^{11/} | 3.2 ^{12/} | | 3.2 ± 0.1 |
| g | 0.5 min. | | u.c. |
| h1 | 0 ^{12/} | | 0 ± 0.1 |
| h2 | 0 ^{12/} | | 0 ± 0.15 |
| γ1 | 50° min. | | 50° min. |
| γ2 | 40° min. | | 40° min. |
| γ3 | 30° min. | | 30° min. |
| Cap: | H16: PGJ19-3 | in accordance with IEC Publication 60061 (sheet 7004-110-2) | |
| | H16B: PGJY19-3 | in accordance with IEC Publication 60061 (sheet 7004-146-1) | |
| Electrical and photometric characteristics | | | |
| Rated values | Volts | 12 | 12 |
| | Watts | 19 | 19 |
| Test voltage | Volts | 13.2 | 13.2 |
| Objective values | Watts | 26 max. | 26 max. |
| | Luminous flux | 500 +10 % / -15 % | |
| Reference luminous flux: 370 lm at approximately 12 V | | | 370 lm |
| Reference luminous flux: 500 lm at approximately 13.2 V | | | 500 lm |
| Reference luminous flux: 550 lm at approximately 13.5 V | | | 550 lm |

^{11/} The ends of the filament are defined as the points where, when the viewing direction is direction A as shown in Figure 1 on sheet H16/1, the projection of the outside of the end turns crosses the filament axis.

^{12/} To be checked by means of a "Box system"; sheet H16/4.

Screen projection requirements

This test is used to determine, by checking whether the filament is correctly positioned relative to the reference axis and reference plane, whether a filament complies with the requirements.

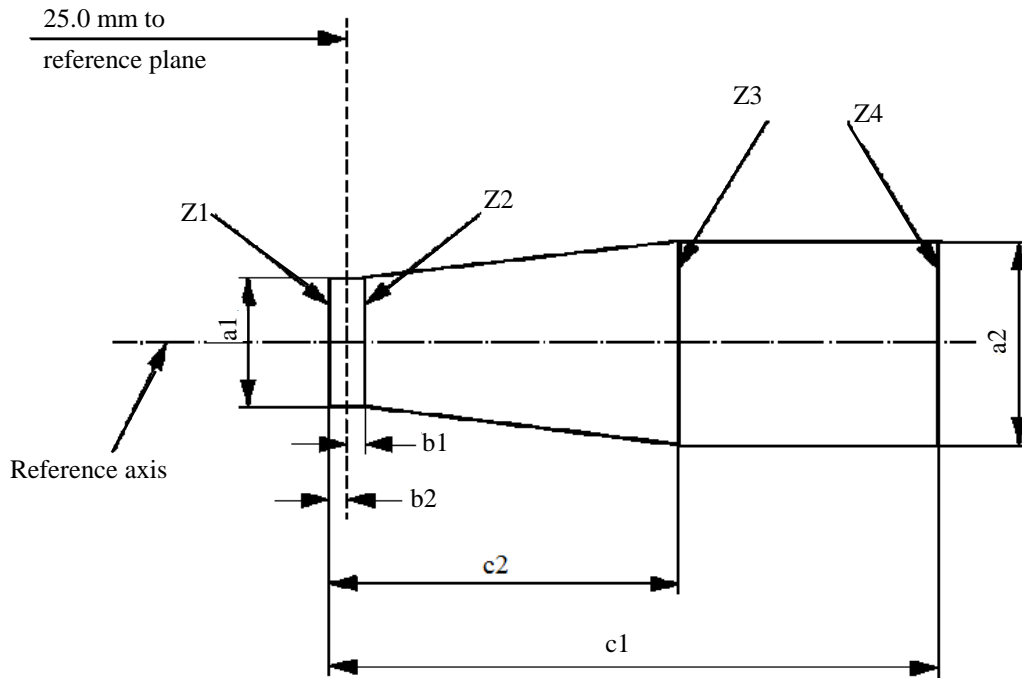

| <i>a1</i> | <i>a2</i> | <i>b1</i> | <i>b2</i> | <i>c1</i> | <i>c2</i> |
|------------|------------|-----------|-----------|-----------|-----------|
| $d + 0.50$ | $d + 0.70$ | 0.25 | | 3.6 | 2.6 |

d = diameter of filament

The filament position is checked solely in directions A and B as shown on sheet H16/1, Figure 1.

The filament shall lie entirely within the limits shown.

The ends of the filament as defined on sheet H16/3, footnote 11/, shall lie between lines Z1 and Z2 and between Z3 and Z4.

The drawings are intended only to illustrate the essential dimensions (in mm) of the filament light source

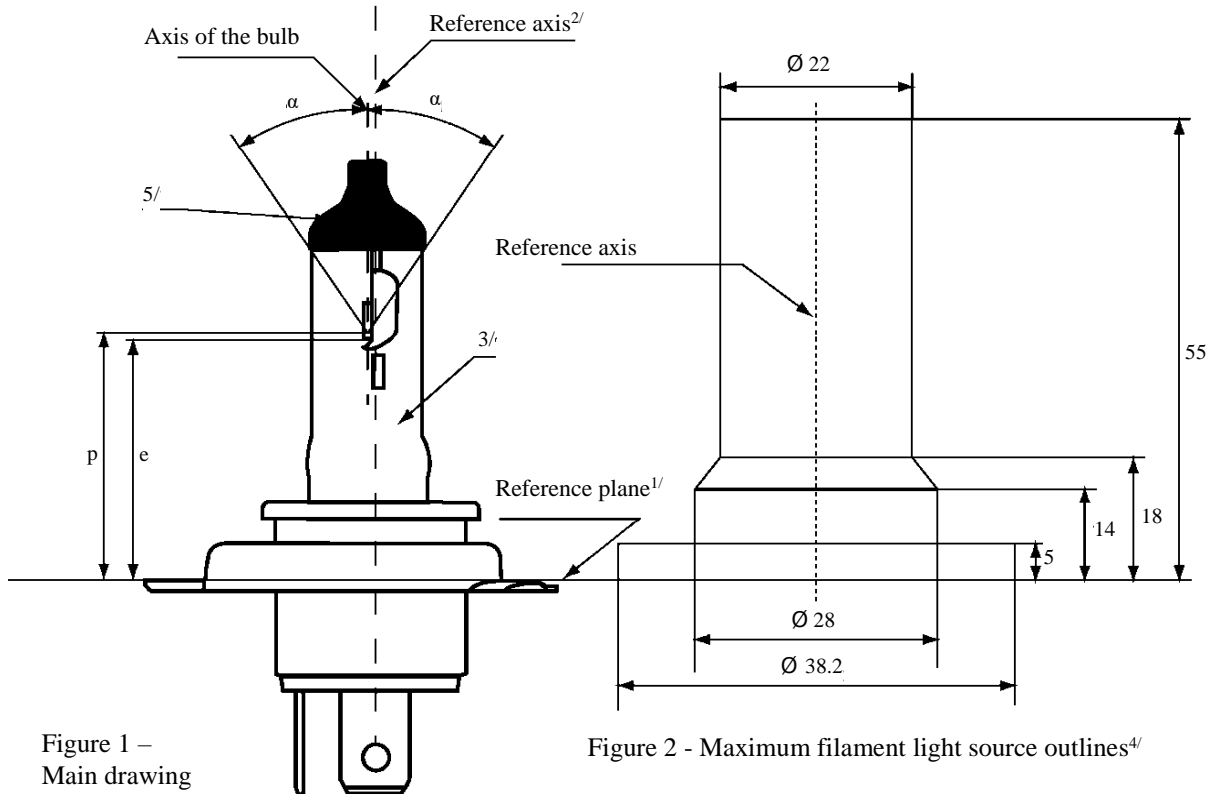
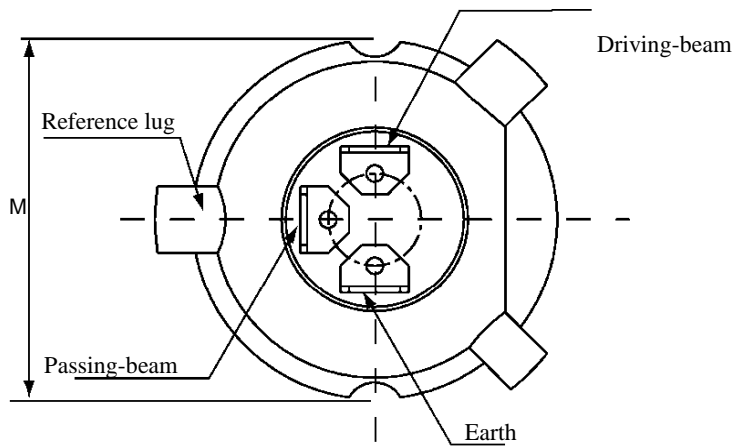

Figure 1 – Main drawing

Figure 2 - Maximum filament light source outlines^{4/}

For the notes see sheet H17/6

| <i>Dimensions in mm</i> | | <i>Filament light sources of normal production</i> | | <i>Standard filament light source</i> | |
|---|---------------|--|------------|---------------------------------------|---------|
| | | <i>12 V</i> | | <i>12 V</i> | |
| e | | 28.5 + 0.35 / - 0.15 | | 28.5 + 0.20 / - 0.0 | |
| p | | 28.95 | | 28.95 | |
| α | | max. 40° | | max. 40° | |
| Cap PU43t-4 in accordance with IEC Publication 60061 (sheet 7004-171-2) | | | | | |
| Electrical and photometric characteristics | | | | | |
| Rated values | Volts | 12 ^{6/} | | 12 ^{6/} | |
| | Watts | 35 | 35 | 35 | 35 |
| Test voltage | Volts | 13.2 | 13.2 | 13.2 | 13.2 |
| Objective values | Watts | 37 max. | 37 max. | 37 max. | 37 max. |
| | Luminous flux | 900 ± 10 % | 600 ± 10 % | | |
| Reference luminous flux at approximately | | | 12.0 V | 700 | 450 |
| | | | 13.2 V | 900 | 600 |

For note 6/ see sheet H17/6

Position of the shield

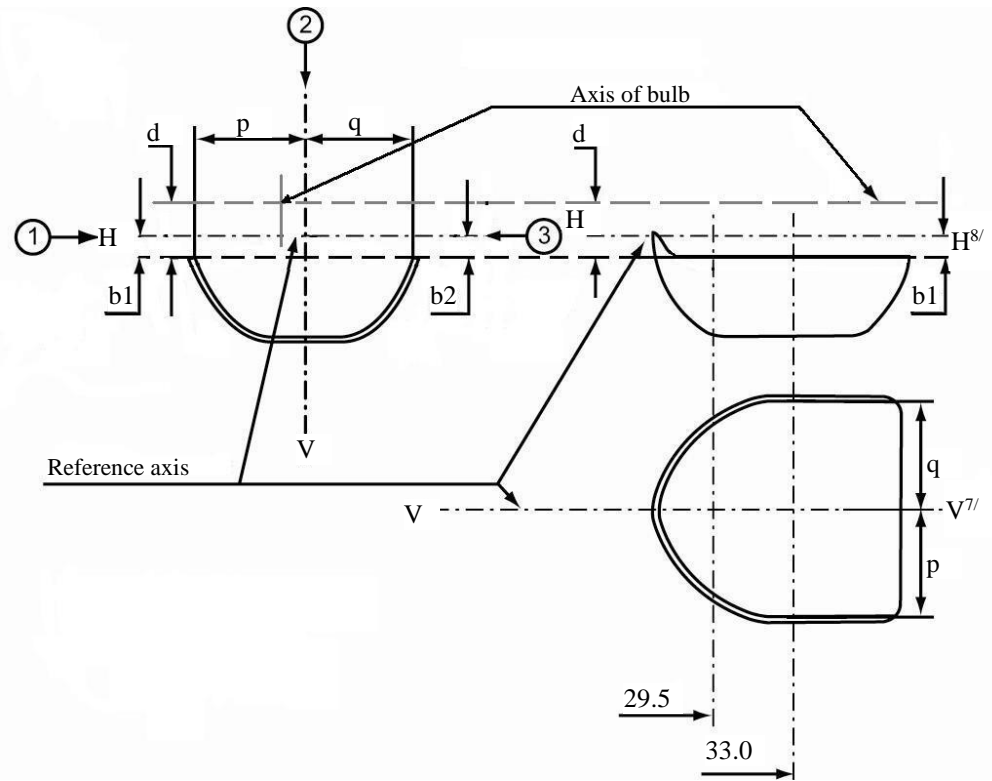

Position of filaments

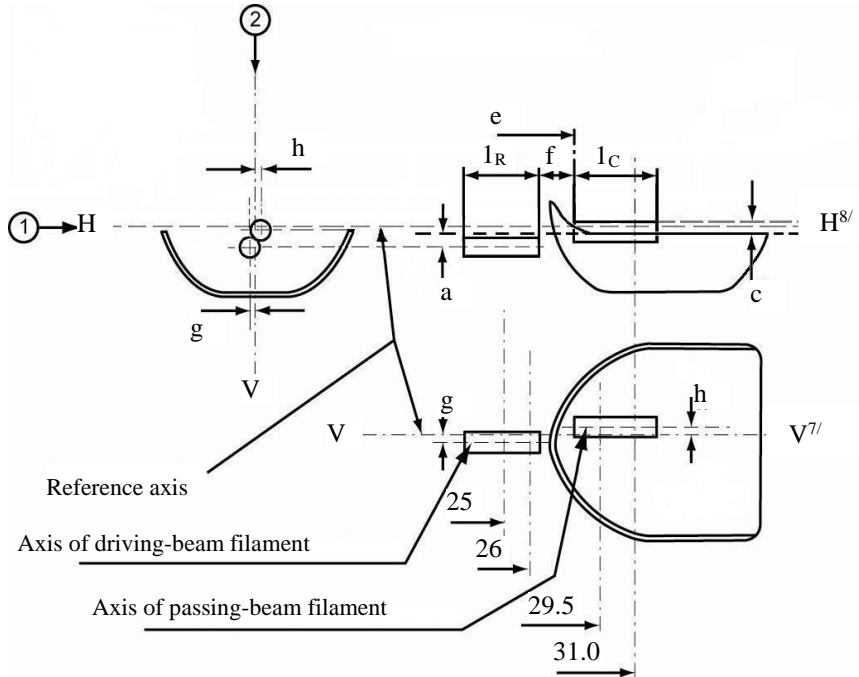

Category H17

Sheet H17/5

Table of the dimensions (in mm) referred to in the drawings on sheets H17/3 and H17/4

| Reference* | Dimension** | Tolerance | |
|---------------------------|------------------------------------|---|--------------------------------|
| | | Filament light sources of normal production | Standard filament light source |
| a/25.0 | 0.3 | ±0.40 | ±0.20 |
| a/26.0 | 0.3 | ±0.35 | ±0.20 |
| b1/29.5 | 0.0 | ±0.30 | ±0.25 |
| b1/33.0 | b1/29.5 mv | ±0.30 | ±0.15 |
| b2/29.5 | 0.0 | ±0.30 | ±0.25 |
| b2/33.0 | b2/29.5 mv | ±0.30 | ±0.15 |
| c/29.5 | 0.5 | ±0.25 | ±0.15 |
| c/31.0 | c/29.5 mv | ±0.25 | ±0.15 |
| d | min. 0.1 | - | - |
| e ^{11/} | 28.5 | +0.35 / -0.15 | +0.20 / -0.0 |
| f ^{9/, 10/, 11/} | 1.7 | ±0.30 | ±0.15 |
| g/25.0 | 0 | ±0.50 | ±0.30 |
| g/26.0 | 0 | ±0.40 | ±0.25 |
| h/29.5 | 0 | ±0.40 | ±0.25 |
| h/31.0 | h/29.5 mv | ±0.30 | ±0.15 |
| lR ^{9/, 12/} | 4.0 | ±0.40 | ±0.20 |
| lC ^{9/, 10/} | 4.2 | ±0.40 | ±0.20 |
| p/33.0 | Depends on the shape of the shield | - | - |
| q/33.0 | (p+q)/2 | ±0.60 | ±0.30 |

* ".../25.0" means dimension to be measured at the distance from the reference plane indicated in mm after the stroke.

** "29.5 mv" means the value measured at a distance of 29.5 mm from the reference plane.

For the notes see sheet H17/6

- ^{1/} The reference plane is the plane formed by the seating points of the three lugs of the cap ring.
- ^{2/} The reference axis is perpendicular to the reference plane and passes through the centre of the circle of diameter "M".
- ^{3/} The light emitted from standard filament light sources and from normal production filament light sources shall be white.
- ^{4/} The bulb and supports shall not exceed the envelope as in Figure 2.
- ^{5/} The obscuration shall extend at least as far as the cylindrical part of the bulb. It shall also overlap the internal shield when the latter is viewed in a direction perpendicular to the reference axis.
- ^{6/} The value indicated in the left hand column relate to the driving beam filament. Those indicated in the right-hand column relate to the passing-beam filament.
- ^{7/} Plane V-V is the plane perpendicular to the reference plane and passing through the reference axis and through the intersection of the circle of diameter "M" with the axis of the reference lug.
- ^{8/} Plane H-H is the plane perpendicular to both the reference plane and plane V-V and passing through the reference axis.
- ^{9/} The end turns of the filament are defined as being the first luminous turn and the last luminous turn that are at substantially the correct helix angle.
- ^{10/} For the passing beam filament, the points to be measured are the intersections, seen in direction 1, of the lateral edge of the shield with the outside of the end turns defined under note 9/.
- ^{11/} "e" denotes the distance from the reference plane to the beginning of the passing filament as defined above.
- ^{12/} For the driving beam filament the points to be measured are the intersections, seen in direction 1, of a plane, parallel to plane H-H and situated at a distance of 0.3 mm below it, with the end turns defined under note 9/.

Additional explanations to sheets H17/3 and H17/4

The dimensions below are measured in three directions:

- 1 For dimensions b1, a, c, d, e, f, lR and lC.
- 2 For dimensions g, h, p and q.
- 3 For dimension b2.

Dimensions p and q are measured in planes parallel to and 33.0 mm away from the reference plane.

Dimensions b1, b2 are measured in planes parallel to and 29.5 mm and 33.0 mm away from the reference plane.

Dimensions c and h are measured in planes parallel to and 29.5 mm and 31.0 mm away from the reference plane.

Dimensions a and g are measured in planes parallel to and 25.0 mm and 26.0 mm away from the reference plane.

Note: For the method of measurement, see Appendix E to IEC Publication 60809.

The drawings are intended only to illustrate the essential dimensions (in mm) of the filament light source

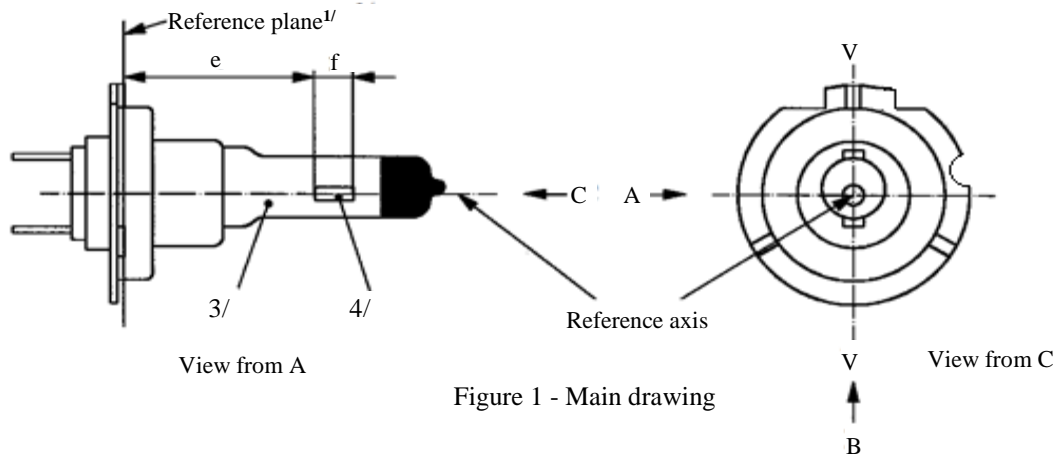
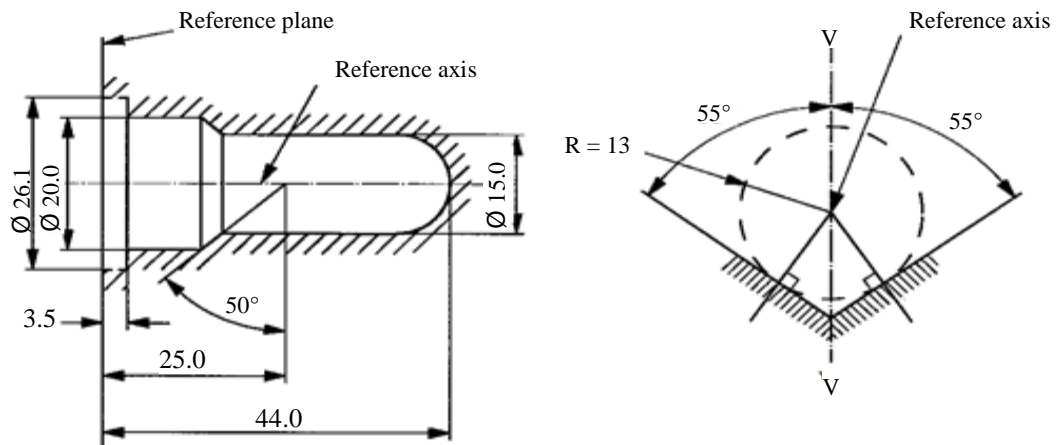

Figure 1 - Main drawing

Figure 2 - Maximum filament light source outline^{5/}Figure 3 - Definition of reference axis^{2/}

^{1/} The reference plane is defined by the points on the surfaces of the holder on which the three supporting bosses of the cap ring will rest.

^{2/} The reference axis is perpendicular to the reference plane and crosses the intersection of the two perpendiculars as indicated in Figure 3.

^{3/} The colour of the light emitted shall be white or selective-yellow.

^{4/} Notes concerning the filament diameter.

(a) No actual diameter restrictions apply but the design target is $d_{max} = 1.3$ mm.

(b) For the same manufacturer, the design diameter of standard (étalon) filament light source and filament light source of normal production shall be the same.

^{5/} Glass bulb and supports shall not exceed the envelope as indicated in Figure 2. The envelope is concentric to the reference axis.

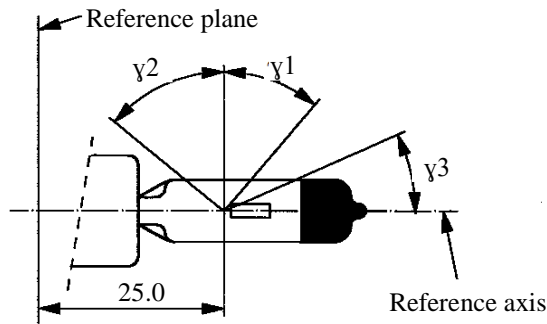

View from B

Figure 4 - Distortion free area and black top^{6/, 7/}

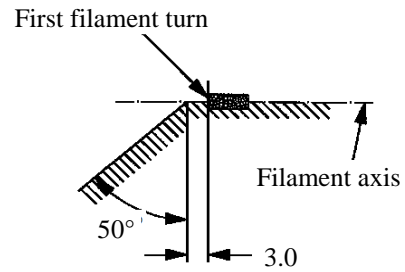

View from A

Figure 5 - Metal free zone^{8/}

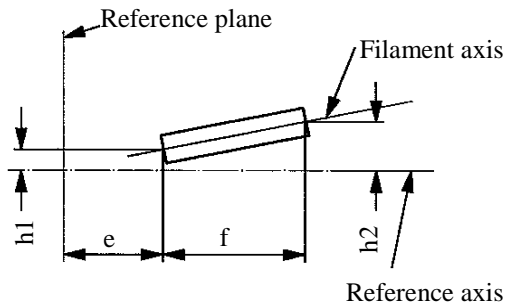

Figure 6 - Permissible offset of filament axis (for standard filament light sources only)

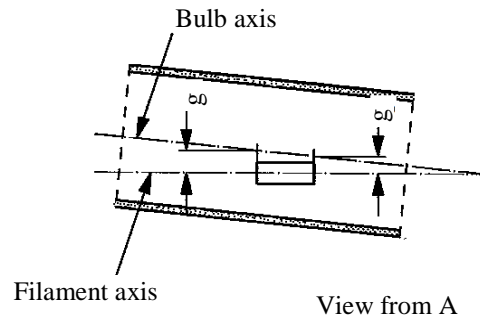

Figure 7 - Bulb eccentricity

- ^{6/} Glass bulb shall be optically distortion free within the angles γ_1 and γ_2 . This requirement applies to the whole bulb circumference within the angles γ_1 and γ_2 .
- ^{7/} The obscuration shall extend at least to the cylindrical part of the bulb on the whole bulb top circumference. It shall moreover extend at least to a plane parallel to the reference plane where γ_3 crosses the outer bulb surface (view B as indicated on sheet H18/1).
- ^{8/} The internal design of the filament light source shall be such that stray light images and reflections are only located above the filament itself seen from the horizontal direction. (View A as indicated in Figure 1 on sheet H18 /1).
No metal parts other than filament turns shall be located in the shaded area as seen in Figure 5.

Category H18

Sheet H18/3

| | <i>Filaments light sources of normal production</i> | | <i>Standard filament light source</i> |
|---|---|-------------|---------------------------------------|
| | 12 V | | 12 V |
| e ^{9/} | 25.0 ^{10/} | | 25.0 ± 0.1 |
| f ^{9/} | 4.8 ^{10/} | | 4.8 ± 0.1 |
| g ^{12/} | 0.5 min. | | u.c. |
| h1 ^{11/} | 0 ^{10/} | | 0 ± 0.10 |
| h2 ^{11/} | 0 ^{10/} | | 0 ± 0.15 |
| γ1 | 40° min. | | 40° min. |
| γ2 | 50° min. | | 50° min. |
| γ3 | 30° min. | | 30° min. |
| Cap PY26d-1 in accordance with IEC Publication 60061 (sheet 7004-5-7) | | | |
| Electrical and photometric characteristics | | | |
| Rated values | Volts | 12 | 12 |
| | Watts | 65 | 65 |
| Test voltage | Volts | 13.2 | 13.2 |
| Objective values | Watts | 69 max. | 69 max. |
| | Luminous flux | 1,700 ± 8 % | |
| Reference luminous flux at approximately | | 13.2 V | 1,700 |

^{9/} The ends of the filament are defined as the points where, when the viewing direction is direction A as shown in Figure 1 on sheet H18/1, the projection of the outside of the end turns crosses the filament axis.

^{10/} To be checked by means of a "Box System", sheet H18/4.

^{11/} The offset of the filament with respect to the reference axis is measured only in viewing directions A and B as shown in Figure 1 in sheet H18/1. The points to be measured are those where the projection of the outside of the end turns nearest to or furthest from the reference plane crosses the filament axis.

^{12/} Offset of filament in relation to bulb axis measured in two planes parallel to the reference plane where the projection of the outside of the end turns nearest to or furthest from the reference plane crosses the filament axis.

Screen projection requirements

This test is used to determine, by checking whether the filament is correctly positioned relative to the reference axis and reference plane, whether a filament light source complies with the requirements.

Dimensions in mm

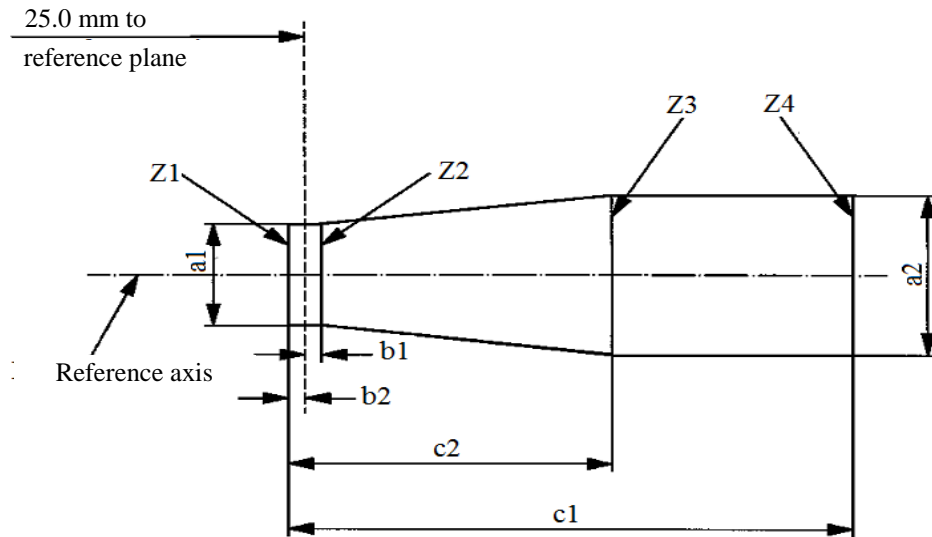

| | <i>a1</i> | <i>a2</i> | <i>b1</i> | <i>b2</i> | <i>c1</i> | <i>c2</i> |
|------|------------|------------|-----------|-----------|-----------|-----------|
| 12 V | $d + 0.30$ | $d + 0.50$ | | 0.2 | 5.3 | 4.7 |

d = diameter of filament

The filament position is checked solely in directions A and B as shown on sheet H18/1, Figure 1.

The filament shall lie entirely within the limits shown.

The ends of the filament as defined on sheet H18/3, note 9, shall lie between lines Z1 and Z2 and between Z3 and Z4.

The drawings are intended only to illustrate the essential dimensions (in mm) of the filament lamp.

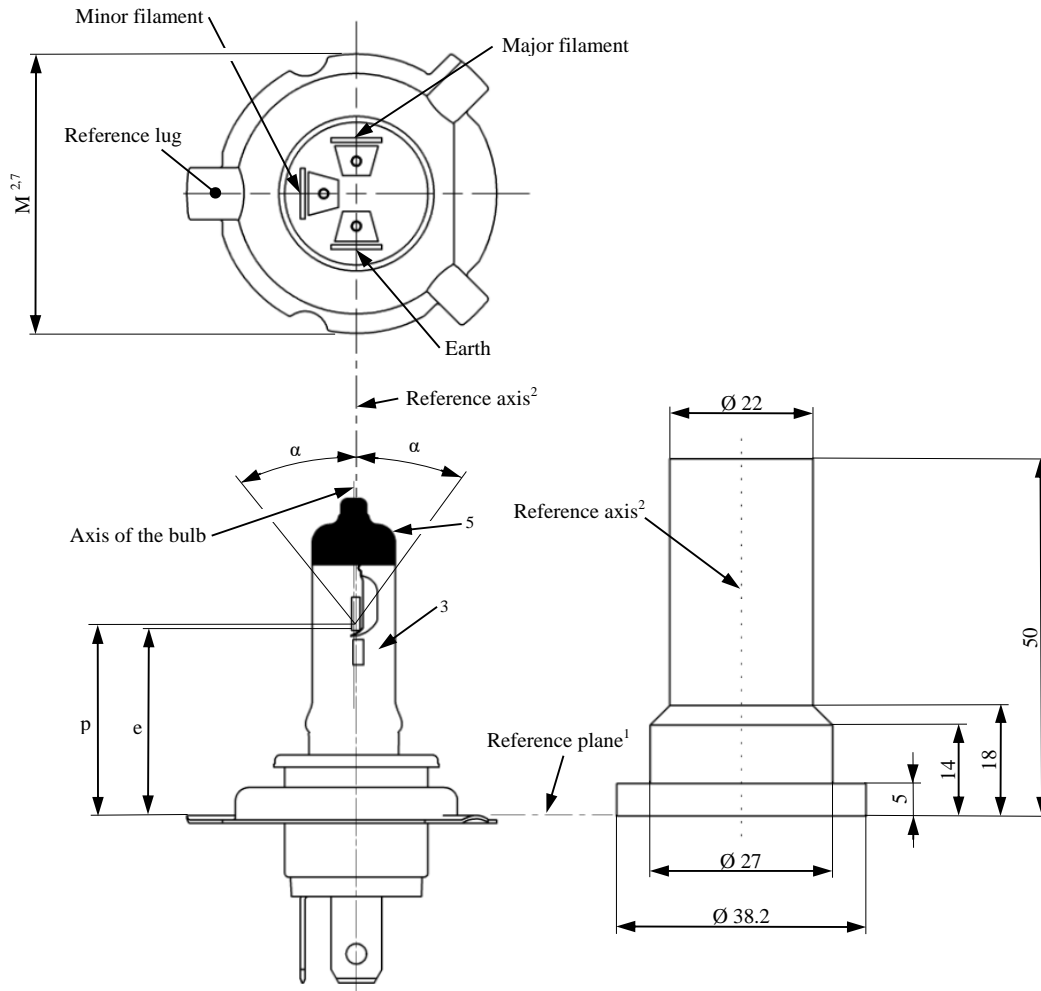

Figure 1
Main drawing

Figure 2
Maximum lamp outlines⁴

For the notes see sheet H19/5.

The drawings are intended only to illustrate the essential dimensions (in mm) of the filament light source.

| <i>Dimensions in mm</i> | <i>Filament lamps of normal production</i> | | <i>Standard filament lamps</i> | | |
|---|--|-----------------|--------------------------------|-----------------|---------|
| | <i>12 V</i> | | <i>12 V</i> | | |
| e | 28.5 + 0.35 / - 0.15 | | 28.5 + 0.20 / - 0.0 | | |
| p | 28.95 | | 28.95 | | |
| α | max. 45° | | max. 45° | | |
| Cap PU43t-3 in accordance with IEC Publication 60061 (sheet 7004-171-1) | | | | | |
| Electrical and photometric characteristics | | | | | |
| Rated values | Volts | 12 ⁶ | | 12 ⁶ | |
| | Watts | 60 | 55 | 60 | 55 |
| Test values | Volts | 13.2 | 13.2 | 13.2 | 13.2 |
| Objective values | Watts | 72 max. | 68 max. | 72 max. | 68 max. |
| | Luminous flux | 1 750 ± 10% | 1 200 ± 10% | | |
| Reference luminous flux at approximately | | | 13.2 V | 1 750 | 1 200 |

For note 6 see sheet H19/5.

Position of shield

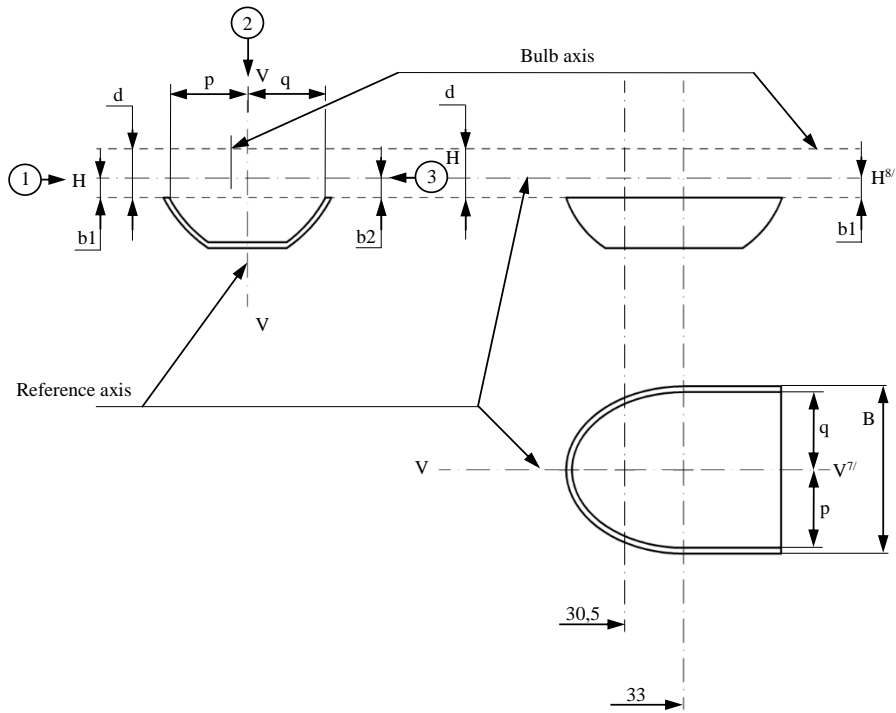

Position of filament

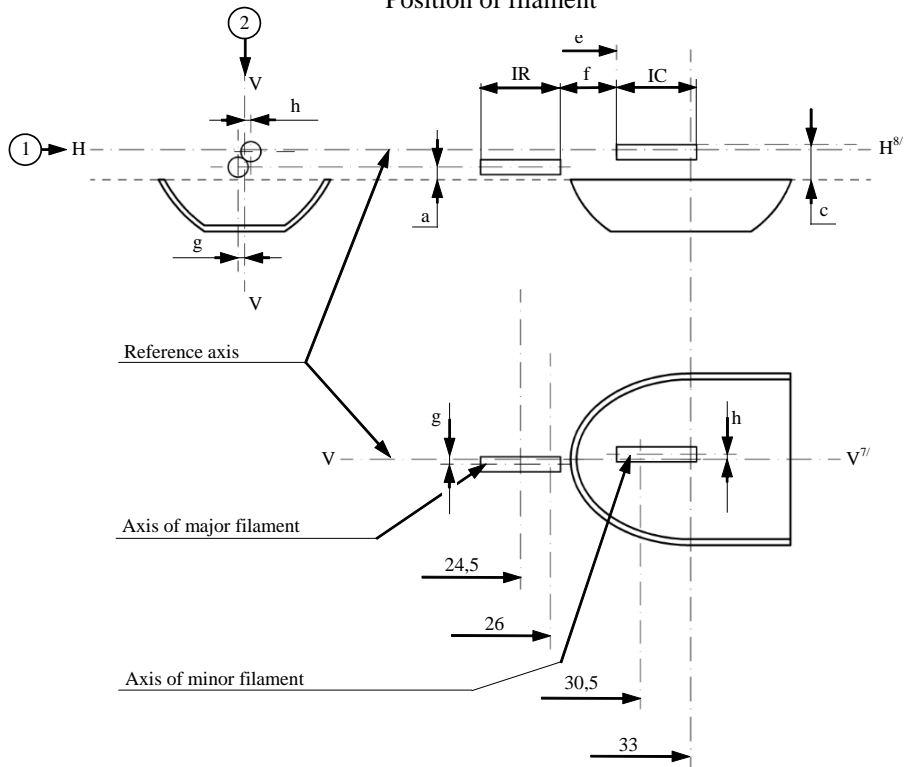

Table of the dimensions (in mm) referred to in the drawings on sheet H19/3

| Reference* | Dimension** | Tolerance | |
|------------------------|------------------------------------|-------------------------------------|-------------------|
| | | Filament lamps of normal production | Standard filament |
| a/26.0 | 0.7 | ±0.30 | ±0.20 |
| a/24.5 | 0.7 | ±0.40 | ±0.20 |
| b1/30.5 | 1.0 | ±0.30 | ±0.25 |
| b1/33.0 | b1/30.5 mv | ±0.30 | ±0.15 |
| b2/30.5 | 1.0 | ±0.30 | ±0.25 |
| b2/33.0 | b2/30.5 mv | ±0.30 | ±0.15 |
| c/30.5 | 1.7 | ±0.25 | ±0.15 |
| c/33 | c/30.5 mv | ±0.25 | ±0.15 |
| d | min. 1.1 | - | - |
| e ¹¹ | 28.5 | +0.35 / -0.15 | +0.20 / -0.0 |
| f ^{9, 10, 11} | 1.4 | ±0.30 | ±0.15 |
| g/26.0 | 0 | ±0.40 | ±0.25 |
| g/24.5 | 0 | ±0.50 | ±0.30 |
| h/30.5 | 0 | ±0.40 | ±0.25 |
| h/33.0 | h/30.5 mv | ±0.30 | ±0.15 |
| IR ^{9, 12} | 4.0 | ±0.60 | ±0.30 |
| IC ^{9, 10} | 5.2 | ±0.60 | ±0.30 |
| p/33.0 | Depends on the shape of the shield | - | - |
| q/33.0 | (p+q)/2 | ±0.50 | ±0.30 |
| B/33.0 | 8.6 | ±0.30 | ±0.30 |

* ".../24.5" means dimension to be measured at the distance from the reference plane indicated in mm after the stroke.

** ".../30.5 mv" means the value measured at a distance of 30.5 mm from the reference plane.

For the notes see sheet H19/5.

Category H19

Sheet H19/5

- ¹ The reference plane is the plane formed by the seating points of the three lugs of the cap ring.
- ² The reference axis is perpendicular to the reference plane and passes through the centre of the circle of diameter "M".
- ³ The light emitted from standard filament lamps and from normal production lamps shall be white.
- ⁴ The bulb and supports shall not exceed the envelope as in Figure 2.
- ⁵ The obscuration shall extend, at least, as far as the cylindrical part of the bulb. It shall also overlap the internal shield when the latter is viewed in a direction perpendicular to the reference axis.
- ⁶ The values indicated in the left hand column relate to the major filament. Those indicated in the right-hand column relate to the minor filament.
- ⁷ Plane V-V is the plane perpendicular to the reference plane and passing through the reference axis and through the intersection of the circle of diameter "M" with the axis of the reference lug.
- ⁸ Plane H-H is the plane perpendicular to both the reference plane and plane V-V and passing through the reference axis.
- ⁹ The end turns of the filament are defined as being the first luminous turn and the last luminous turn that are at substantially the correct helix angle.
- ¹⁰ For the minor filament, the points to be measured are the intersections, seen in direction 1, of either the lateral edge of the shield or the filament axis with the outside of the end turns defined under note 9.
- ¹¹ "e" denotes the distance from the reference plane to the beginning of the minor filament as defined above.
- ¹² For the major filament the points to be measured are the intersections, seen in direction 1, of a plane, parallel to plane H-H and situated at a distance of 0.3 mm below it, with the end turns defined under note 9.

Additional explanations to sheet H19/3

The dimensions below are measured in three directions:

- 1 For dimensions b1, a, c, d, e, f, IR and IC.
- 2 For dimensions g, h, p, q and B.
- 3 For dimension b2.

Dimensions B, p and q are measured in planes parallel to and 33.0 mm away from the reference plane.

Dimensions b1, b2 are measured in planes parallel to and 30.5 mm and 33.0 mm away from the reference plane.

Dimensions c and h are measured in planes parallel to and 30.5 mm and 33.0 mm away from the reference plane.

Dimensions a and g are measured in planes parallel to and 24.5 mm and 26.0 mm away from the reference plane.

Note: For the method of measurement, reference is made to Appendix E of IEC Publication 60809.

The drawings are intended only to illustrate the essential dimensions (in mm) of the filament light source

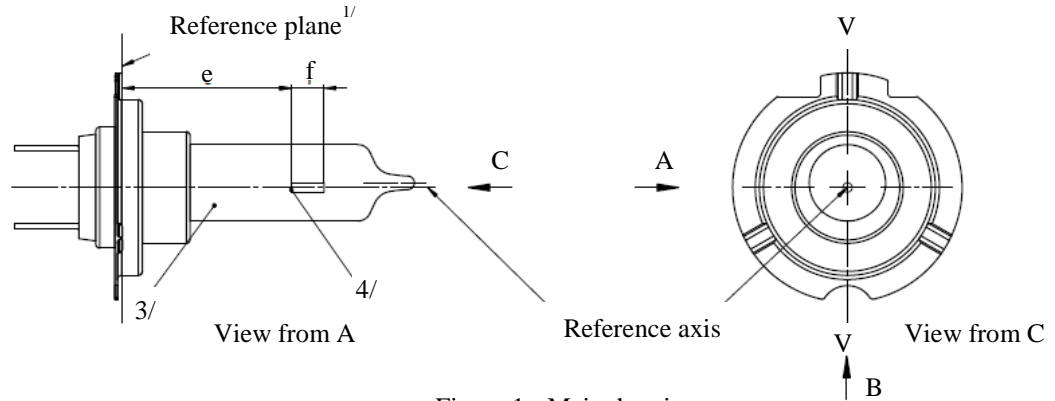

Figure 1 - Main drawing

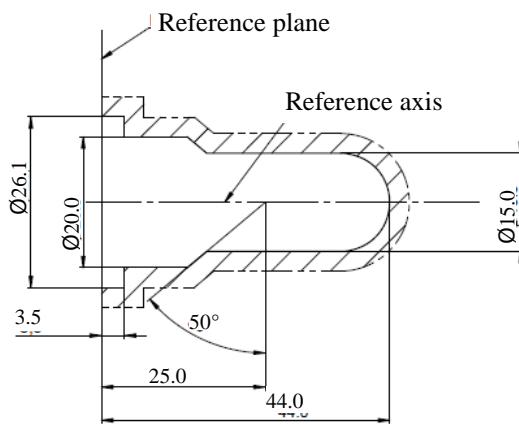

Figure 2 - Maximum filament light source outline^{5/}

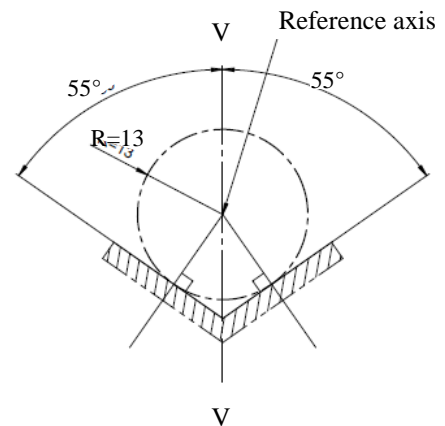

Figure 3 - Definition of reference axis^{2/}

- ^{1/} The reference plane is defined by the points on the surfaces of the holder on which the three supporting bosses of the cap ring will rest.
- ^{2/} The reference axis is perpendicular to the reference plane and crosses the intersection of the two perpendiculars as indicated in Figure 3.
- ^{3/} The colour of the light emitted shall be white with the restriction according to sheet H20/3.
- ^{4/} Notes concerning the filament diameter:
 - (a) No actual diameter restrictions apply but the design target is to have $d_{max} = 1.4$ mm.
 - (b) For the same manufacturer, the design diameter of standard (étalon) filament light source and filament light source of normal production shall be the same.
- ^{5/} Glass bulb and supports shall not exceed the envelope as indicated in Figure 2. The envelope is concentric to the reference axis.

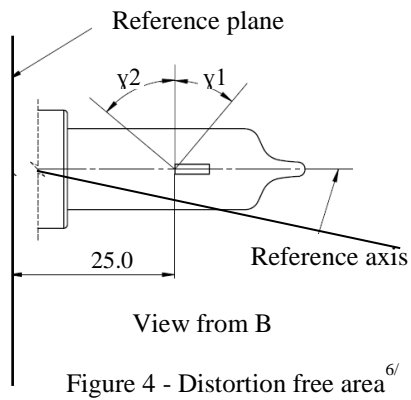

Figure 4 - Distortion free area ^{6/}

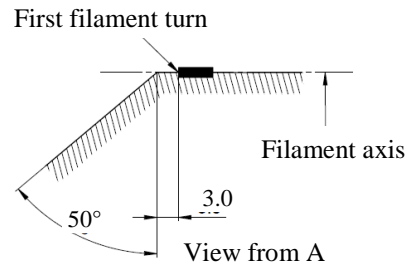

Figure 5 - Metal free zone ^{7/}

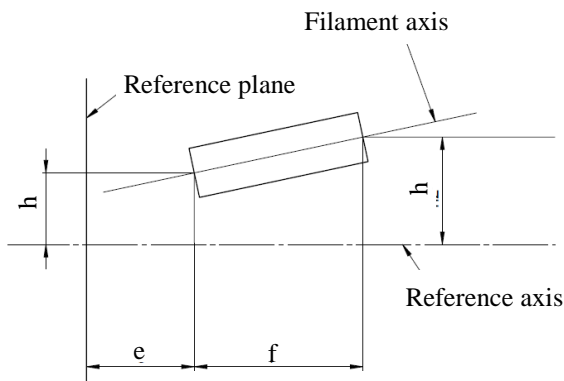

Figure 6 - Permissible offset of filament axis
(for standard filament light sources only)

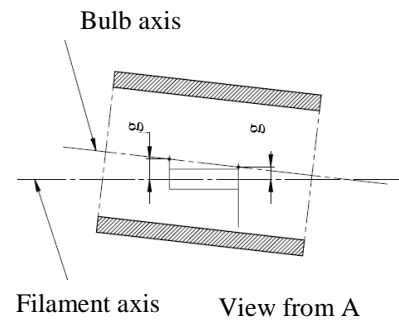

Figure 7 - Bulb eccentricity

^{6/} Glass bulb shall be optically distortion free within the angles γ_1 and γ_2 . This requirement applies to the whole bulb circumference within the angles γ_1 and γ_2 .

^{7/} The internal design of the filament light source shall be such that stray light images and reflections are only located above the filament itself seen from the horizontal direction. (View A as indicated in Figure 1 on sheet H20/1).

No metal parts other than filament turns shall be located in the shaded area as seen in Figure 5.

| Dimensions in mm | | Filaments light sources of normal production | Standard filament light source | |
|---|----------------|--|--------------------------------|----------------|
| | | 12 V | 12 V | |
| e ^{8/} | | 25.0 ^{9/} | 25.0 ± 0.1 | |
| f ^{8/} | | 4.8 ^{9/} | 4.8 ± 0.1 | |
| g ^{11/} | | 0.5 min. | 0.5 min. | |
| h1 ^{10/} | | 0 ^{9/} | 0 ± 0.10 | |
| h2 ^{10/} | | 0 ^{9/} | 0 ± 0.15 | |
| γ1 | | 40° min. | 40° min. | |
| γ2 | | 50° min. | 50° min. | |
| Cap PY26d-6 in accordance with IEC Publication 60061 (sheet 7004-5-7) | | | | |
| Electrical and photometric characteristics | | | | |
| Rated values | Volts | 12 | 12 | |
| | Watts | 70 | 70 | |
| Test voltage | Volts | 13.2 | 13.2 | |
| Objective values | Watts | 75 max. | 75 max. | |
| | Luminous flux | 1 250 ± 10 % | | |
| Reference luminous flux at approximately | | 12 V | 900 | |
| | | 13.2 V | 1250 | |
| Chromaticity Coordinates | Objective | | x=0.347 | y=0.353 |
| | Tolerance area | Boundaries | x=0.330 | y=0.150+0.640x |
| | | | x=0.370 | y=0.050+0.750x |
| | | Intersection points | x=0.330 | y=0.298 |
| | | | x=0.370 | y=0.327 |
| | x=0.370 | y=0.387 | | |
| x=0.330 | y=0.361 | | | |

^{8/} The ends of the filament are defined as the points where, when the viewing direction is direction A as shown in Figure 1 on sheet H20/1, the projection of the outside of the end turns crosses the filament axis. (Special instructions for coiled-coil filaments are under consideration).

^{9/} To be checked by means of a "Box System", sheet H20/4.

^{10/} The offset of the filament with respect to the reference axis is measured only in viewing directions A and B as shown in Figure 1 in sheet H20/1. The points to be measured are those where the projection of the outside of the end turns nearest to or furthest from the reference plane crosses the filament axis.

^{11/} Offset of filament in relation to bulb axis measured in two planes parallel to the reference plane where the projection of the outside of the end turns nearest to or furthest from the reference plane crosses the filament axis.

Screen projection requirements

This test is used to determine, by checking whether the filament is correctly positioned relative to the reference axis and reference plane, whether a filament light source complies with the requirements.

Dimensions in mm

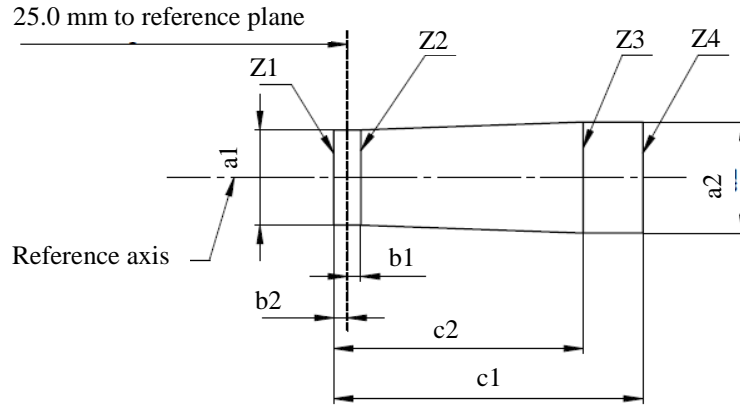

| <i>a1</i> | <i>a2</i> | <i>b1</i> | <i>b2</i> | <i>c1</i> | <i>c2</i> |
|------------|------------|-----------|-----------|-----------|-----------|
| $d + 0.40$ | $d + 0.70$ | 0.25 | | 5.7 | 4.6 |

d = diameter of filament

The filament position is checked solely in directions A and B as shown on sheet H20/1, Figure 1.

The filament shall lie entirely within the limits shown.

The ends of the filament as defined on sheet H20/3, note 9, shall lie between lines Z1 and Z2 and between Z3 and Z4.

The drawings are intended only to illustrate the essential dimensions (in mm) of the filament light source

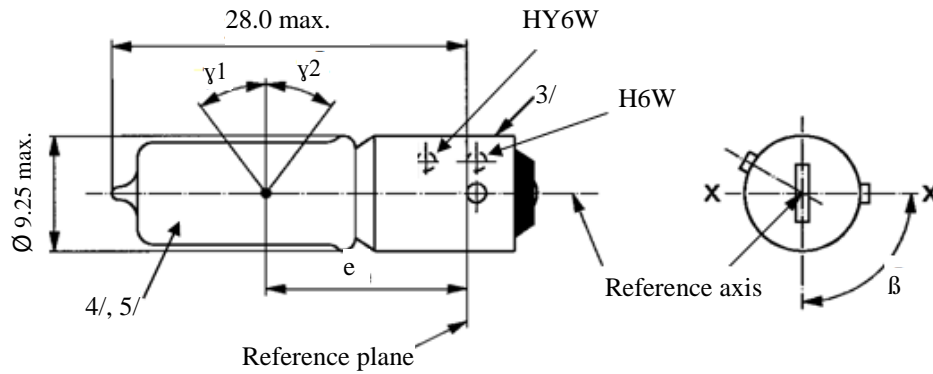

| Dimensions in mm | | Filament light sources of normal production | | | Standard filament light source |
|---|---------------------------|--|------------|-------|--------------------------------|
| | | Min. | Nom. | Max. | |
| e | | 14.25 | 15.0 | 15.75 | 15.0 ± 0.25 |
| Lateral deviation ^{1/} | | | | 0.75 | 0.4 max |
| β | | 82.5° | 90° | 97.5° | 90° ± 5° |
| γ1, γ2 ^{2/} | | 30° | | | 30° min. |
| Cap: | H6W: BAX9s HY6W: BAZ9s | in accordance with IEC Publication 60061 (sheet 7004-8-1) in accordance with IEC Publication 60061 (sheet 7004-150-1) | | | |
| Electrical and photometric characteristics | | | | | |
| Rated values | Volts | 12 | | | 12 |
| | Watts | 6 | | | 6 |
| Test | Volts | 13.5 | | | 13.5 |
| Objective values | Watts | 7.35 max. | | | 7.35 max. |
| | Luminous flux | H6W | 125 ± 12 % | | |
| | | HY6W | 75 ± 17 % | | |
| Reference luminous flux at approximately 13.5 V | | | | | White: 125 lm Amber: 75 lm |

^{1/} Maximum lateral deviation of filament centre from two mutually perpendicular planes both containing the reference axis and one containing axis X-X.

^{2/} In the area between the outer legs of the angles γ1 and γ2, the bulb shall have no optically distorting areas and the curvature of the bulb shall have a radius not less than 50 per cent of the actual bulb diameter.

^{3/} Over the entire length of the cap there shall be no projections or soldering exceeding the permissible maximum diameter of the cap.

^{4/} The light emitted from filament light sources of normal production shall be white for category H6W and amber for category HY6W.

^{5/} The light emitted from standard filament light sources shall be white for category H6W and amber or white for category HY6W.

Categories H10W/1 and HY10W

Sheet H10W/1

The drawings are intended only to illustrate the essential dimensions (in mm) of the filament light source

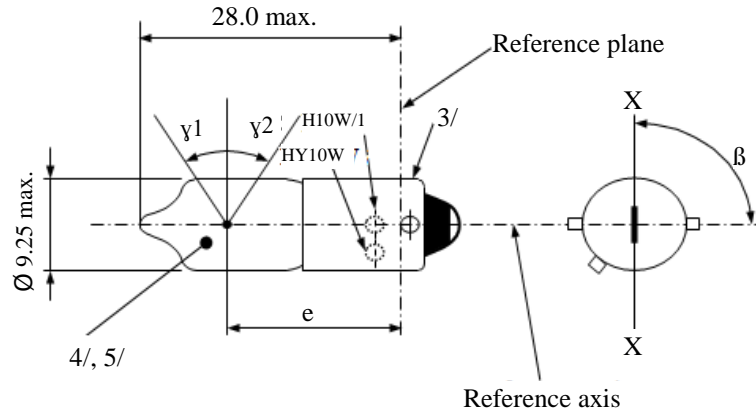

| Dimensions in mm | | Filament light sources of normal production | | | Standard filament light source |
|---|---------------|---|------------|-------|--------------------------------|
| | | Min. | Nom. | Max. | |
| e | | 14.25 | 15.0 | 15.75 | 15.0 ± 0.25 |
| Lateral deviation ^{1/} | | | | 0.75 | 0.4 max |
| β | | 82.5° | 90° | 97.5° | 90° ± 5° |
| γ1, γ2 ^{2/} | | 30° | | | 30° min. |
| Cap: H10W/1 BAU9s in accordance with IEC Publication 60061 (sheet 7004-150A-1) HY10W BAUZ9s in accordance with IEC Publication 60061 (sheet 7004-150B-1) | | | | | |
| Electrical and photometric characteristics | | | | | |
| Rated values | Volts | 12 | | | 12 |
| | Watts | 10 | | | 10 |
| Test voltage | Volts | 13.5 | | | 13.5 |
| Objective values | Watts | 12 max. | | | 12 max. |
| | Luminous flux | H10W/1 | 200 ± 12 % | | |
| | | HY10W | 120 ± 17 % | | |
| Reference luminous flux at approximately 13.5 V | | | | | White: 200 lm Amber: 120 lm |

- ^{1/} Maximum lateral deviation of filament centre from two mutually perpendicular planes both containing the reference axis and one containing axis X-X.
- ^{2/} In the area between the outer legs of the angles γ_1 and γ_2 , the bulb shall have no optically distorting areas and the curvature of the bulb shall have a radius not less than 50 per cent of the actual bulb diameter.
- ^{3/} Over the entire length of the cap there shall be no projections or soldering exceeding the permissible maximum diameter of the cap.
- ^{4/} The light emitted from filament light sources of normal production shall be white for category H10W/1 and amber for category HY10W.
- ^{5/} The light emitted from standard filament light sources shall be white for category H10W/1 and amber or white for category HY10W.

Categories H21W and HY21W

Sheet H21W/1

The drawings are intended only to illustrate the essential dimensions (in mm) of the filament light source.

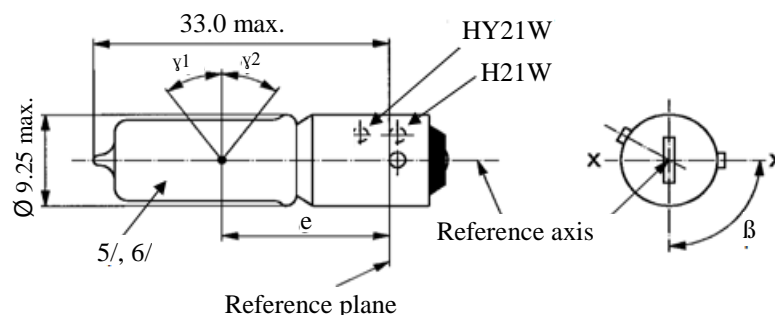

| Dimensions in mm | | Filament light sources of normal production | | | Standard filament light source |
|--|---------------|---|---|---------------|--------------------------------|
| | | Min. | Nom. | Max. | |
| e | | | 20.0 ^{1/} | | 20.0 ± 0.25 |
| f | 12 V | | | 3.8 | 3.8 + 0 / -1 |
| | 24 V | | | 4.5 | |
| Lateral deviation ^{2/} | | | | ^{1/} | 0.0 ± 0.15 ^{3/} |
| β | | 82.5° | 90° | 97.5° | 90° ± 5° |
| γ1, γ2 ^{4/} | | 45° | | | 45° min. |
| Cap: | | H21W: BAY9s | in accordance with IEC Publication 60061 (sheet 7004-9-1) | | |
| | | HY21W: BAW9s | in accordance with IEC Publication 60061 (sheet 7004-149-1) | | |
| Electrical and photometric characteristics | | | | | |
| Rated values | Volts | 12 | 24 | 12 | |
| | Watts | 21 | 21 | 21 | |
| Test voltage | Volts | 13.5 | 28.0 | 13.5 | |
| Objective values | Watts | 26.25 max. | 29.4 max. | 26.25 max. | |
| | Luminous flux | H21W | 600 ± 12 % | 600 ± 15 % | |
| | | HY21W | 300 ± 17 % | 300 ± 20 % | |
| Reference luminous flux at approximately | | | | 12 V | White: 415 lm |
| | | | | 13.2 V | White: 560 lm |
| | | | | 13.5 V | White: 600 lm Amber: 300 lm |

^{1/} To be checked by means of a "Box system", sheet H21W/2.

^{2/} Maximum lateral deviation of filament centre from two mutually perpendicular planes both containing the reference axis and one containing axis X-X.

^{3/} The lateral deviation with respect to the plane perpendicular to axis X-X is measured in the position described in paragraph 1. of the test procedure specified on sheet H21W/2.

^{4/} In the area between the outer legs of the angles γ1 and γ2, the bulb shall have no optical distorting areas and the curvature of the bulb shall have a radius not less than 50 per cent of the actual bulb diameter.

^{5/} The light emitted from filament light sources of normal production shall be white for category H21W and amber for category HY21W.

^{6/} The light emitted from standard filament light sources shall be white for category H21W and amber or white for category HY21W.

Screen projection requirements

This test is used to determine, by checking whether the filament is correctly positioned relative to the reference axis and reference plane and has an axis perpendicular, within $\pm 7.5^\circ$, to the plane through the centre line of the reference pin and the reference axis, whether a filament light source complies with the requirements.

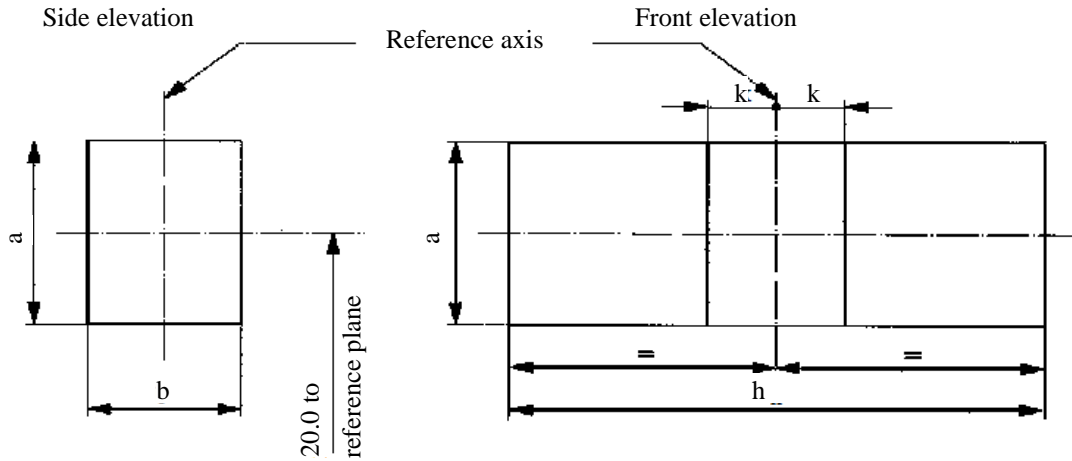

| Reference | a | b | h | k |
|-----------|---------|---------|---------|------|
| Dimension | d + 1.0 | d + 1.0 | f + 1.2 | 0.50 |

d = actual filament diameter
 f = actual filament length

Test procedures and requirements

1. The filament light source is placed in a holder capable of being rotated about its axis and having either a calibrated scale or fixed stops corresponding to the angular displacement tolerance limits. The holder is then so rotated that an end view of the filament is seen on the screen on to which the image of the filament is projected. The end view of the filament shall be obtained within the angular displacements tolerance limits.
2. Side elevation
 The filament light source placed with the cap down, the reference axis vertical and the filament seen end-on, the projection of the filament shall lie entirely within a rectangle of height "a" and width "b", having its centre at the theoretical position of the centre of the filament.
3. Front elevation
 The filament light source placed with the cap down and the reference axis vertical, the filament light source being viewed in a direction at right angles to the filament axis:
 - 3.1. The projection of the filament shall lie entirely within a rectangle of height "a" and width "h", having its centre at the theoretical position of the centre of the filament;
 - 3.2. The centre of the filament shall not be offset by more than distance "k" from the reference axis.

Categories H27W/1 and H27W/2

Sheet H27W/1

The drawings are intended only to illustrate the essential dimensions (in mm) of the filament light source.

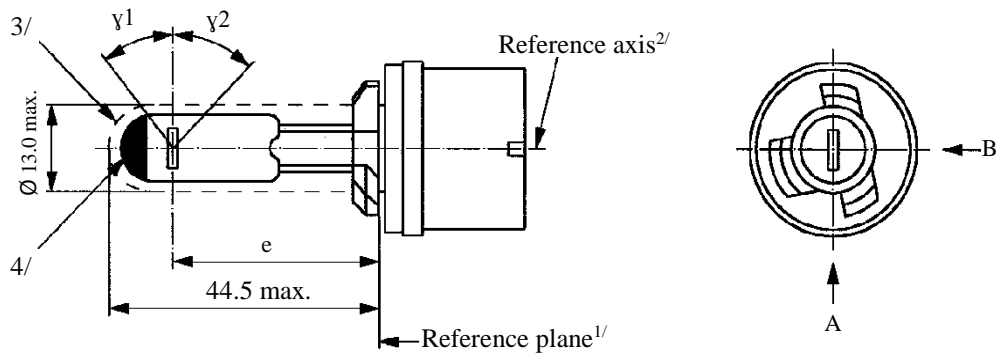

Category H27W/1

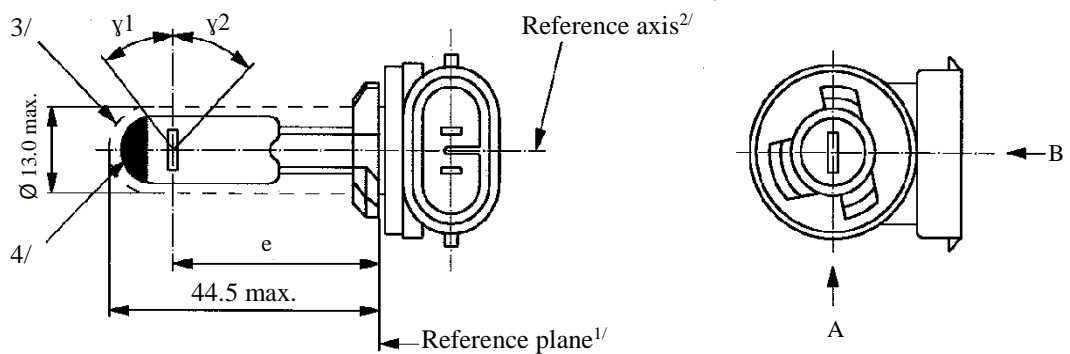

Category H27W/2

- ^{1/} The reference plane is defined by the plane formed by the underside of the bevelled lead-in flange of the cap.
- ^{2/} The reference axis is perpendicular to the reference plane and passes through the centre of the 13.10 mm cap diameter.
- ^{3/} Glass bulb and supports shall not exceed the size of a theoretical cylinder centred on the reference axis.
- ^{4/} The obscuration shall extend over the whole bulb top including the bulb cylindrical portion up to the intersection with γ_1 .

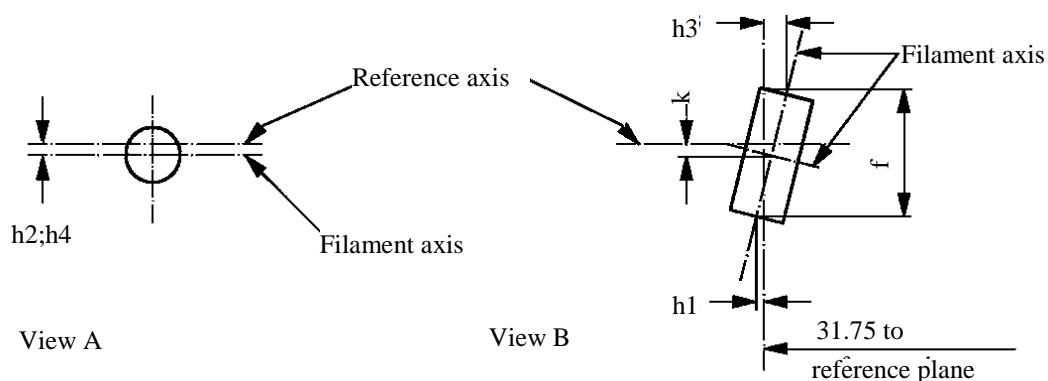

Filament dimensions and position

(Dimensions f for all filament light sources)

(Dimensions h1, h2, h3, h4 and k for standard filament light sources only)

| Dimensions in mm | Filament light source of normal production | Standard filament light source | |
|--|---|--------------------------------|---------|
| e | 31.75 ^{6/} | 31.75 ± 0.25 | |
| f ^{8/} | 4.8 max. | 4.2 ± 0.20 | |
| k | 0 ^{6/} | 0.0 ± 0.25 | |
| h1, h2, h3, h4 ^{7/} | 0 ^{6/} | 0.0 ± 0.25 | |
| γ_1 ^{5/} | 38° nom. | 38° nom. | |
| γ_2 ^{5/} | 44° nom. | 44° nom. | |
| Cap: H27W/1: PG13 H27W/2: PGJ13 | in accordance with IEC Publication 60061 (sheet 7004-107-4) | | |
| Electrical and photometric characteristics | | | |
| Rated values | Volts | 12 | 12 |
| | Watts | 27 | 27 |
| Test voltage | Volts | 13.5 | 13.5 |
| Objective values | Watts | 31 max. | 31 max. |
| | Luminous flux | 477 ± 15 % | |
| Reference luminous flux at approximately | | 12 V | 350 lm |
| | | 13.2 V | 450 lm |
| | | 13.5 V | 477 lm |

^{5/} Glass bulb shall be optically distortion free within the angles γ_1 and γ_2 . This requirement applies to the whole bulb circumference within the angles γ_1 and γ_2 .

^{6/} To be checked by means of a "Box system", sheet H27W/3.

^{7/} For standard filament light sources, the points to be measured are those where the projection of the outside of the end turns crosses the filament axis.

^{8/} The ends of the filament are defined by the intersections of the outside of the first and of the last light emitting turn, respectively, with the plane parallel to and 31.75 mm from the reference plane.

Screen projection requirements

This test is used to determine, by checking whether the filament is correctly positioned relative to the reference axis and reference plane, whether a filament light source complies with the requirements.

Dimensions in mm

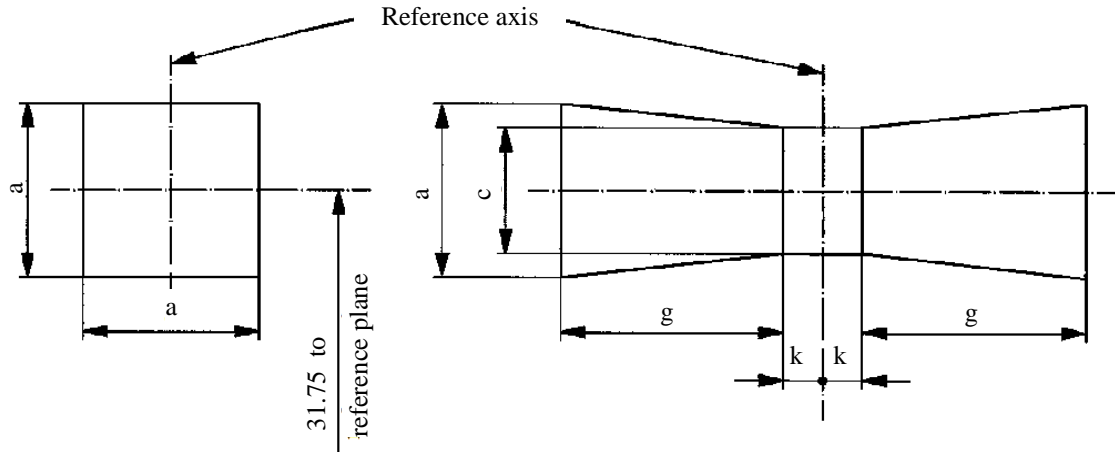

| Reference | a | c | k | g |
|------------|-----------|-----------|-----|-----|
| Dimensions | $d + 1.2$ | $d + 1.0$ | 0.5 | 2.4 |

d = actual diameter of filament

The filament shall lie entirely within the limits shown.

The centre of the filament shall lie within the limits of dimension k .

The drawings are intended only to illustrate the essential dimensions (in mm) of the filament light source.

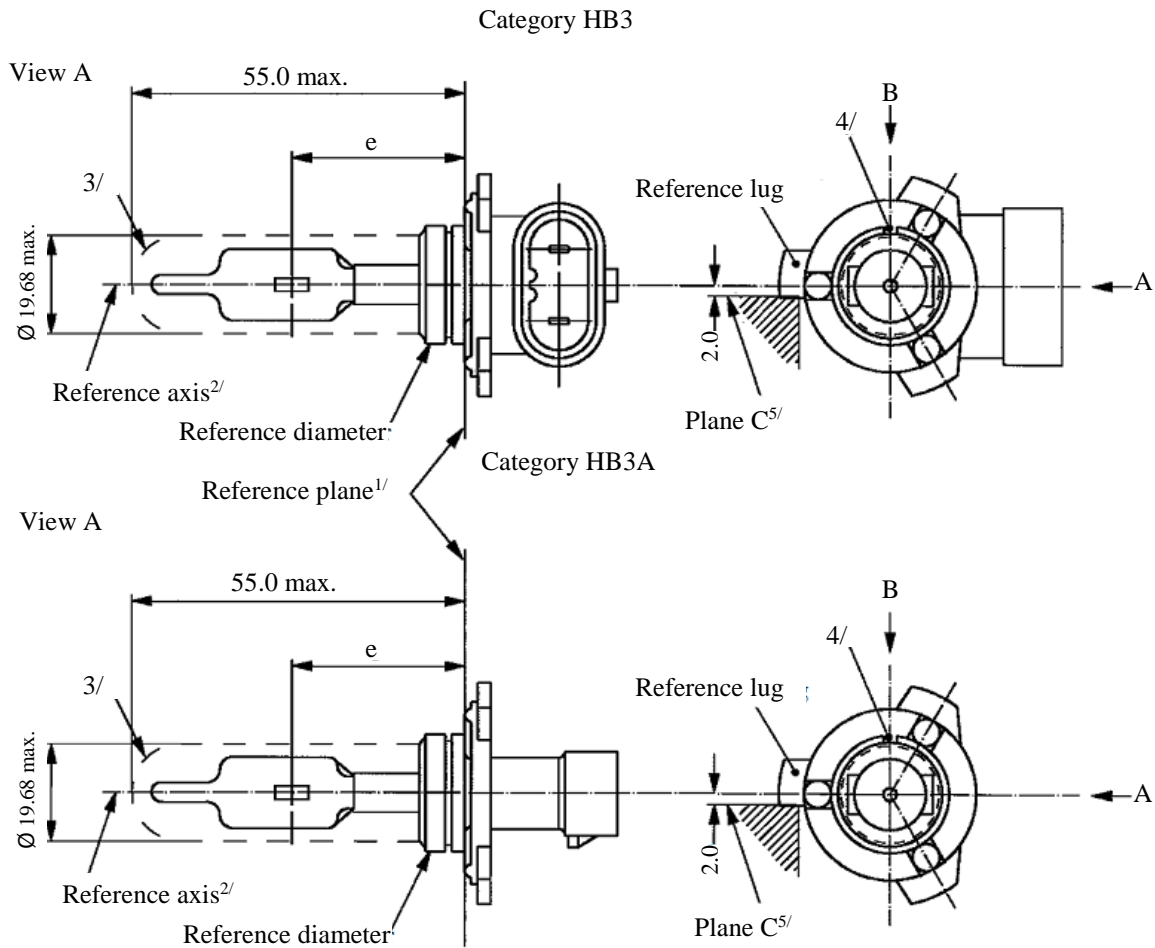

- ^{1/} The reference plane is the plane defined by the meeting points of cap-holder fit.
- ^{2/} The reference axis is perpendicular to the reference plane and concentric with the reference diameter of the cap.
- ^{3/} Glass bulb and supports shall not exceed the envelope and shall not interfere with insertion past the filament light source key.
- ^{4/} The keyway is mandatory for category HB3A and optional for category HB3.
- ^{5/} The filament light source shall be rotated in the measuring holder until the reference lug contacts plane C of the holder.

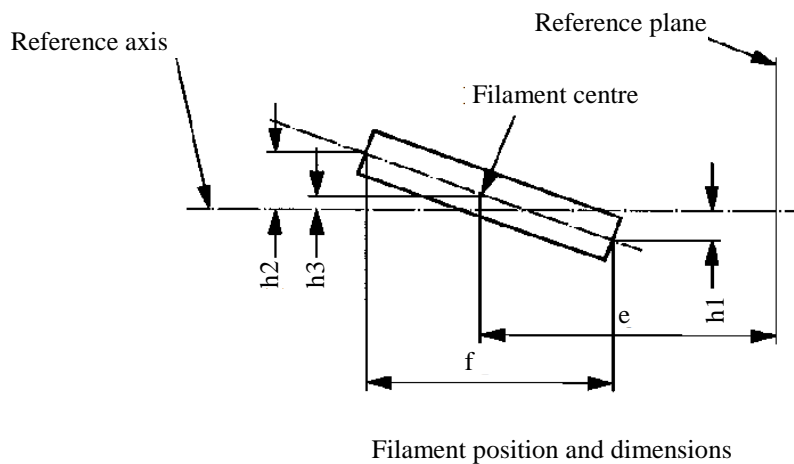
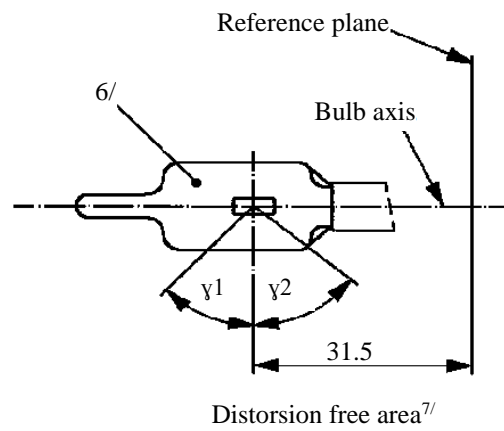

^{6/} The colour of the light emitted shall be white or selective-yellow.

^{7/} Glass bulb periphery shall be optically distortion-free axially within the angles γ_1 and γ_2 . This requirement applies to the whole bulb circumference within the angles γ_1 and γ_2 .

| Dimensions in mm ^{12/} | | Tolerance | |
|--|---------------|---|--------------------------------|
| | | Filament light sources of normal production | Standard filament light source |
| e ^{9/, 11/} | 31.5 | 10/ | ±0.16 |
| f ^{9/, 11/} | 5.1 | 10/ | ±0.16 |
| h1, h2 | 0 | 10/ | ±0.15 ^{8/} |
| h3 | 0 | 10/ | ±0.08 ^{8/} |
| γ1 | 45° min. | - | - |
| γ2 | 52° min. | - | - |
| Cap P20d in accordance with IEC Publication 60061 (sheet 7004-31-2) ^{13/} | | | |
| Electrical and photometric characteristics | | | |
| Rated values | Volts | 12 | 12 |
| | Watts | 60 | 60 |
| Test voltage | Volts | 13.2 | 13.2 |
| Objective values | Watts | 73 max. | 73 max. |
| | Luminous flux | 1,860 ± 12 % | |
| Reference luminous flux at approximately | | 12 V | 1,300 |
| | | 13.2 V | 1,860 |

^{8/} The eccentricity is measured only in viewing directions* A and B as shown in the figure on sheet HB3/1. The points to be measured are those where the projection of the outside of the end turns nearest to or furthest from the reference plane crosses the filament axis.

^{9/} The viewing direction is direction* B as shown in the figure on sheet HB3/1.

^{10/} To be checked by means of a "Box system"; sheet HB3/4*.

^{11/} The ends of the filament are defined as the points where, when the viewing direction* as defined in footnote 9/ above, the projection of the outside of the end turns crosses the filament axis.

^{12/} Dimensions shall be checked with O-ring removed.

^{13/} Filament light source HB3 shall be equipped with the right-angle cap and filament light source HB3A with the straight cap.

* Manufacturers may choose another set of perpendicular viewing directions. The viewing directions specified by the manufacturer are to be used by the testing laboratory when checking filament dimensions and position.

Screen projection requirements

This test is used to determine, by checking whether the filament is correctly positioned relative to the reference axis and reference plane, whether a filament light source complies with the requirements.

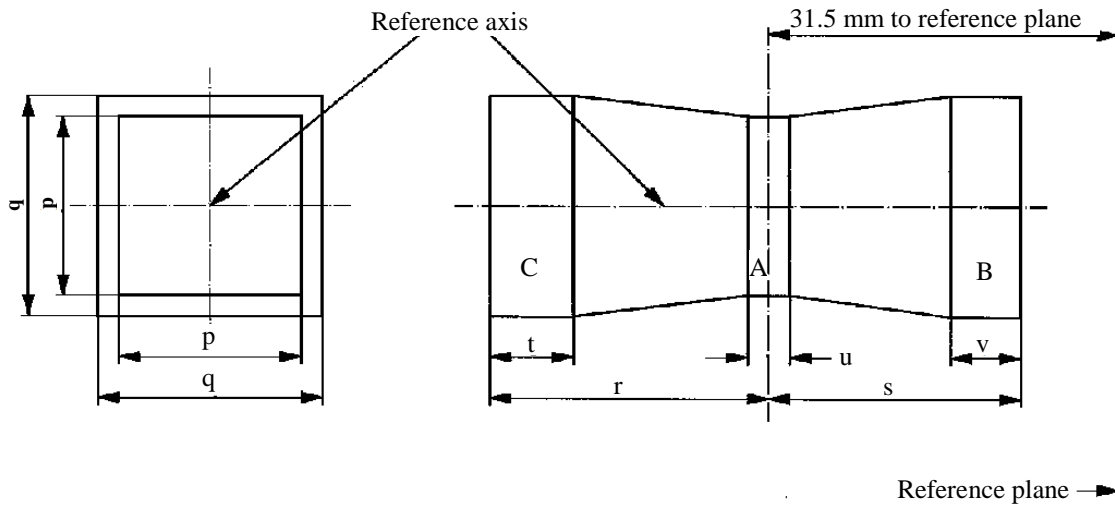

| | p | q | r | s | t | u | v |
|------|---------|---------|-----|-----|-----|-----|-----|
| 12 V | $1.3 d$ | $1.6 d$ | 3.0 | 2.9 | 0.9 | 0.4 | 0.7 |

d = diameter of filament

The filament position is checked solely in directions A and B as shown on sheet HB3/1.

The filament shall lie entirely within the limits shown.

The beginning of the filament, as defined on sheet HB3/3, footnote 11/, shall lie in volume "B" and the end of the filament in volume "C".

Volume "A" does not involve any filament centre requirement.

The drawings are intended only to illustrate the essential dimensions (in mm) of the filament light source.

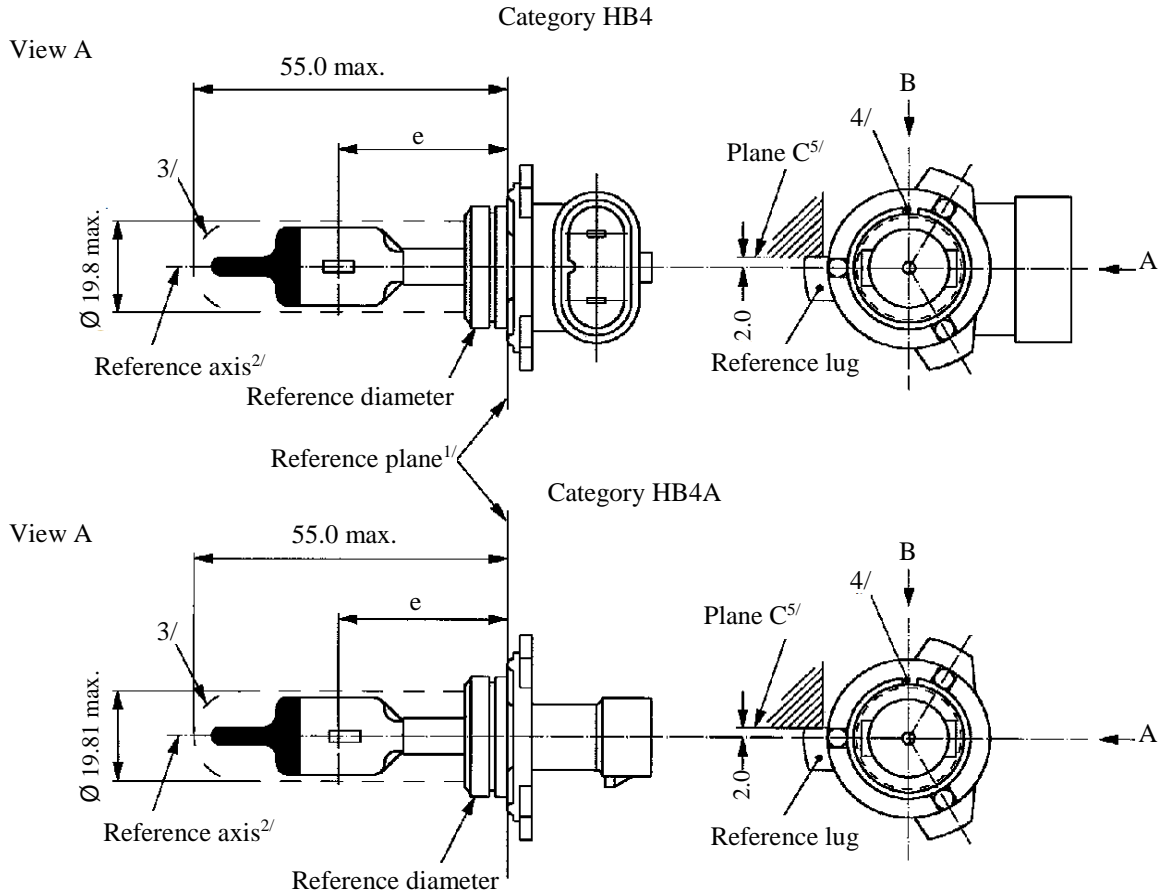

- ^{1/} The reference plane is the plane defined by the meeting points of cap-holder fit.
- ^{2/} The reference axis is perpendicular to the reference plane and concentric with the reference diameter of the cap.
- ^{3/} Glass bulb and supports shall not exceed the envelope and shall not interfere with insertion past the filament light source key. The envelope is concentric to the reference axis.
- ^{4/} The keyway is mandatory for category HB4A and optional for category HB4.
- ^{5/} The filament shall be rotated in the measuring holder until the reference lug contacts plane C of the holder.

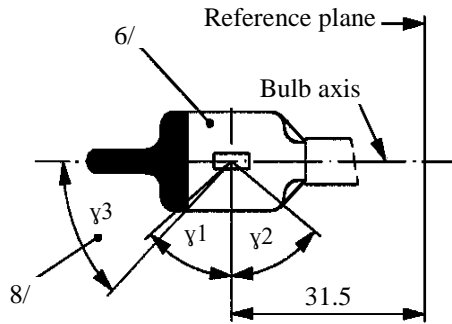

Distorsion free area^{7/} and black top^{8/}

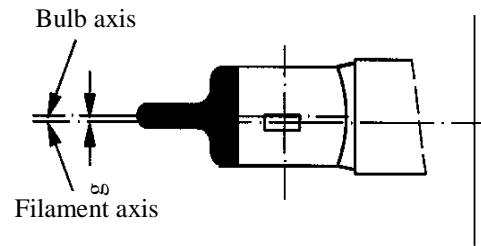

Bulb eccentricity

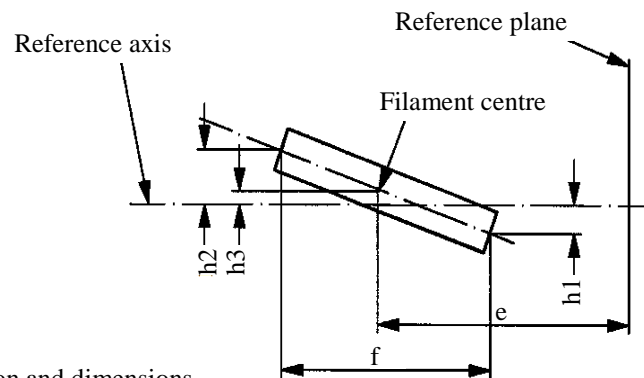

Filament position and dimensions

- ^{6/} The colour of the light emitted shall be white or selective-yellow.
- ^{7/} Glass bulb periphery shall be optically distortion-free axially and cylindrically within the angles γ_1 and γ_2 . This requirement applies to the whole bulb circumference within the angles γ_1 and γ_2 and does not need to be verified in the area covered by the obscuration.
- ^{8/} The obscuration shall extend to at least angle γ_3 and shall be at least as far as the undistorted part of the bulb defined by angle γ_1 .

| Dimensions in mm ^{13/} | | Tolerance | |
|--|---------------|---|--------------------------------|
| | | Filament light sources of normal production | Standard filament light source |
| e ^{10/, 12/} | 31.5 | ^{11/} | ±0.16 |
| f ^{10/, 12/} | 5.1 | ^{11/} | ±0.16 |
| h1, h2 | 0 | ^{11/} | ±0.15 ^{9/} |
| h3 | 0 | ^{11/} | ±0.08 ^{9/} |
| g ^{10/} | 0.75 | ±0.5 | ±0.3 |
| γ1 | 50° min. | - | - |
| γ2 | 52° min. | - | - |
| γ3 | 45° | ±5° | ±5° |
| Cap P22d in accordance with IEC Publication 60061 (sheet 7004-32-2) ^{14/} | | | |
| Electrical and photometric characteristics | | | |
| Rated values | Volts | 12 | 12 |
| | Watts | 51 | 51 |
| Test voltage | Volts | 13.2 | 13.2 |
| Objective values | Watts | 62 max. | 62 max. |
| | Luminous flux | 1,095 ± 15 % | |
| Reference luminous flux at approximately | | 12 V | 825 |
| | | 13.2 V | 1,095 |

^{9/} The eccentricity is measured only in viewing directions* A and B as shown in the figure on sheet HB4/1. The points to be measured are those where the projection of the outside of the end turns nearest to or furthest from the reference plane crosses the filament axis.

^{10/} The viewing direction is direction* B as shown in the figure on sheet HB4/1.

^{11/} To be checked by means of a "Box system"; sheet HB4/4*.

^{12/} The ends of the filament are defined as the points where, when the viewing direction* as defined in footnote 10/ above, the projection of the outside of the end turns crosses the filament axis.

^{13/} Dimensions shall be checked with O-ring removed.

^{14/} Filament light source HB4 shall be equipped with the right-angle cap and filament light source HB4A with the straight cap.

* Manufacturers may choose another set of perpendicular viewing directions. The viewing directions specified by the manufacturer are to be used by the testing laboratory when checking filament dimensions and position.

Screen projection requirements

This test is used to determine, by checking whether the filament is correctly positioned relative to the reference axis and reference plane, whether a filament light source complies with the requirements.

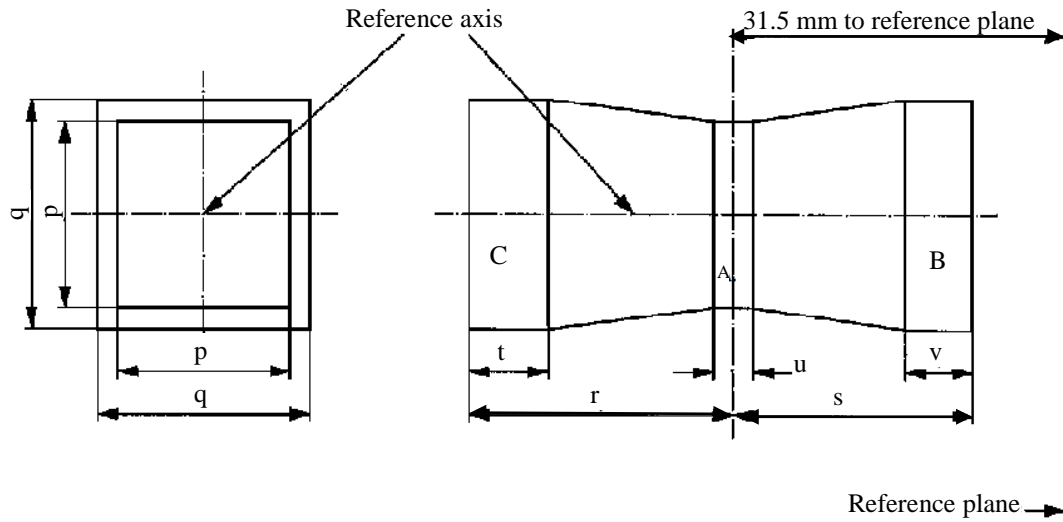

| | p | q | r | s | t | u | v |
|------|-------|-------|-----|-----|-----|-----|-----|
| 12 V | 1.3 d | 1.6 d | 3.0 | 2.9 | 0.9 | 0.4 | 0.7 |

d = diameter of filament

The filament position is checked solely in directions A and B as shown on sheet HB4/1.

The filament shall lie entirely within the limits shown.

The beginning of the filament as defined on sheet HB4/3 footnote 12/ shall lie in volume "B" and the end of the filament in volume "C".

Volume "A" does not involve any filament centre requirement.

The drawings are intended only to illustrate the essential dimensions (in mm) of the filament light source.

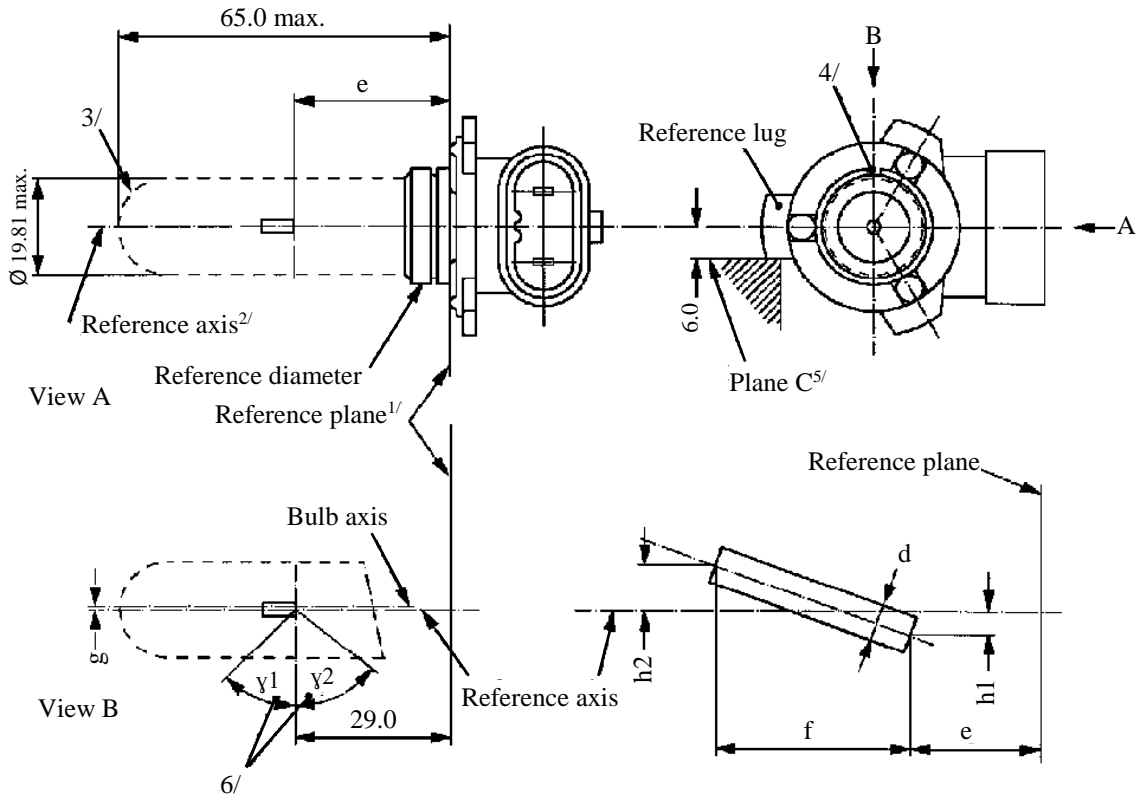

- ^{1/} The reference plane is the plane defined by the three supporting bosses on the cap flange.
- ^{2/} The reference axis is perpendicular to the reference plane and concentric with the reference diameter of the cap.
- ^{3/} Glass bulb and supports shall not exceed the envelope. The envelop is concentric to the reference axis.
- ^{4/} The keyway is mandatory.
- ^{5/} The filament shall be rotated in the measuring holder until the reference lug contacts plane C of the holder.
- ^{6/} Glass bulb periphery shall be optically distortion-free axially within the angles γ_1 and γ_2 . This requirement applies to the whole bulb circumference within the angles γ_1 and γ_2 .

Category HIR1

Sheet HIR1/2

| Dimensions in mm ^{11/} | | Tolerance | |
|--|---------------|---|--------------------------------|
| | | Filament light sources of normal production | Standard filament light source |
| e ^{8/, 10/} | 29 | ^{9/} | ±0.16 |
| f ^{8/, 10/} | 5.1 | ^{9/} | ±0.16 |
| g ^{8/} | 0 | +0.7 / -0.0 | +0.4 / -0.0 |
| h1, h2 | 0 | ^{9/} | ±0.15 ^{7/} |
| d | 1.6 max. | | |
| γ1 | 50° min. | - | - |
| γ2 | 50° min. | - | - |
| Cap PX20d in accordance with IEC Publication 60061 (sheet 7004-31-2) | | | |
| Electrical and photometric characteristics | | | |
| Rated values | Volts | 12 | 12 |
| | Watts | 65 | 65 |
| Test voltage | Volts | 13.2 | 13.2 |
| Objective values | Watts | 73 max. | 73 max. |
| | Luminous flux | 2,500 ± 15 % | |
| Reference luminous flux at approximately | | 12 V | 1,840 |
| | | 13.2 V | 2,500 |

^{7/} The eccentricity is measured only in viewing directions A and B as shown in the figure on sheet HIR1/1. The points to be measured are those where the projection of the outside of the end turns nearest to or furthest from the reference plane crosses the filament axis.

^{8/} The viewing direction is direction B as shown in the figure on sheet HIR1/1.

^{9/} To be checked by means of a "Box system"; sheet HIR1/3.

^{10/} The ends of the filament are defined as the points where, when the viewing direction as defined in footnote 8/ above, the projection of the outside of the end turns crosses the filament axis.

^{11/} Dimensions shall be checked with O-ring mounted.

Screen projection requirements

This test is used to determine, by checking whether the filament is correctly positioned relative to the reference axis and reference plane, whether a filament light source complies with the requirements.

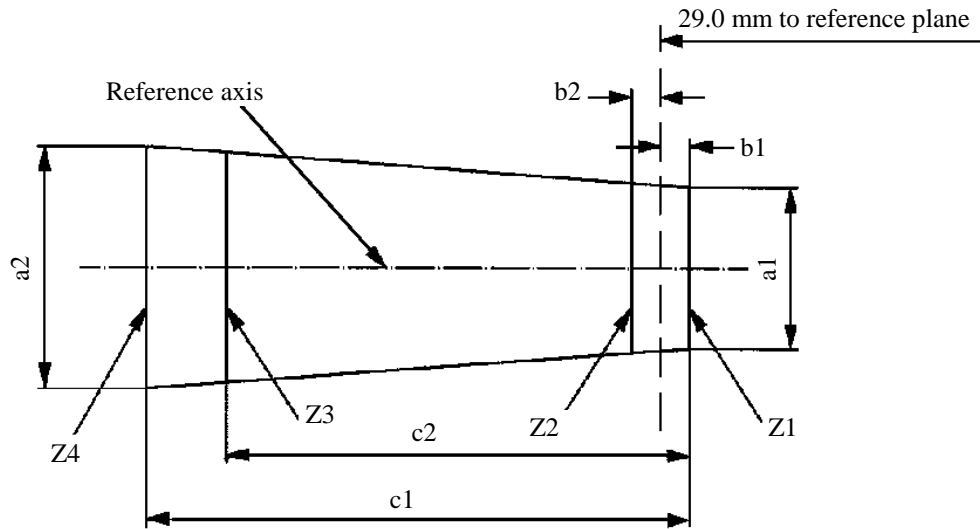

| | <i>a1</i> | <i>a2</i> | <i>b1</i> | <i>b2</i> | <i>c1</i> | <i>c2</i> |
|------|-----------|-----------|-----------|-----------|-----------|-----------|
| 12 V | $d + 0.4$ | $d + 0.8$ | 0.35 | | 6.1 | 5.2 |

d = diameter of filament

The filament position is checked solely in directions A and B as shown on sheet HIR1/1.

The ends of the filament as defined on sheet HIR1/2 footnote 10/ shall lie between lines Z1 and Z2 and between lines Z3 and Z4.

The drawings are intended only to illustrate the essential dimensions (in mm) of the filament light source.

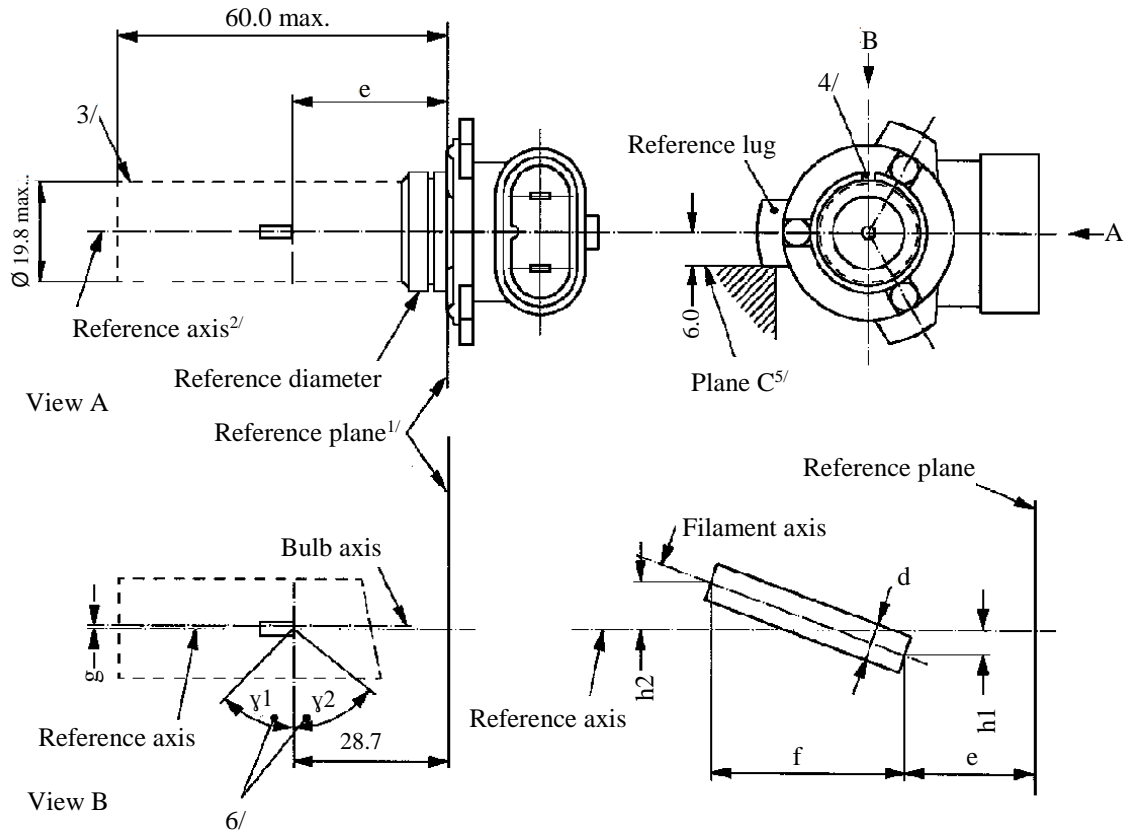

- ^{1/} The reference plane is the plane defined by the three meeting points of the cap holder fit.
- ^{2/} The reference axis is perpendicular to the reference plane and passes through the centre of the reference diameter of the cap.
- ^{3/} Glass bulb and supports shall not exceed the envelope. The envelop is concentric to the reference axis.
- ^{4/} The keyway is mandatory.
- ^{5/} The filament light source shall be rotated in the measuring holder until the reference lug contacts plane C of the holder.
- ^{6/} Glass bulb periphery shall be optically distortion-free axially within the angles γ_1 and γ_2 . This requirement applies to the whole bulb circumference within the angles γ_1 and γ_2 .

| <i>Dimensions in mm ^{11/}</i> | | <i>Tolerance</i> | |
|--|---------------|--|---------------------------------------|
| | | <i>Filament light sources of normal production</i> | <i>Standard filament light source</i> |
| e ^{8/, 10/} | 28.7 | ^{9/} | ±0.16 |
| f ^{8/, 10/} | 5.3 | ^{9/} | ±0.16 |
| g ^{8/} | 0 | +0.7 / -0.0 | +0.4 / -0.0 |
| h1, h2 | 0 | ^{9/} | ±0.15 ^{7/} |
| d | 1.6 max. | - | - |
| γ1 | 50° min. | - | - |
| γ2 | 50° min. | - | - |
| Cap PX22d in accordance with IEC Publication 60061 (sheet 7004-32-2) | | | |
| Electrical and photometric characteristics | | | |
| Rated values | Volts | 12 | 12 |
| | Watts | 55 | 55 |
| Test voltage | Volts | 13.2 | 13.2 |
| Objective values | Watts | 63 max. | 63 max. |
| | Luminous flux | 1,875 ± 15 % | |
| Reference luminous flux at approximately | | 12 V | 1,355 |
| | | 13.2 V | 1,875 |

^{7/} The eccentricity is measured only in viewing directions A and B as shown in the figure on sheet HIR2/1. The points to be measured are those where the projection of the outside of the end turns nearest to or furthest from the reference plane crosses the filament axis.

^{8/} The viewing direction is direction B as shown in the figure on sheet HIR2/1.

^{9/} To be checked by means of a "Box system"; sheet HIR2/3.

^{10/} The ends of the filament are defined as the points where, when the viewing direction as defined in footnote 8/ above, the projection of the outside of the end turns crosses the filament axis.

^{11/} Dimensions shall be checked with O-ring removed.

Screen projection requirements

This test is used to determine, by checking whether the filament is correctly positioned relative to the reference axis and reference plane, whether a filament light source complies with the requirements.

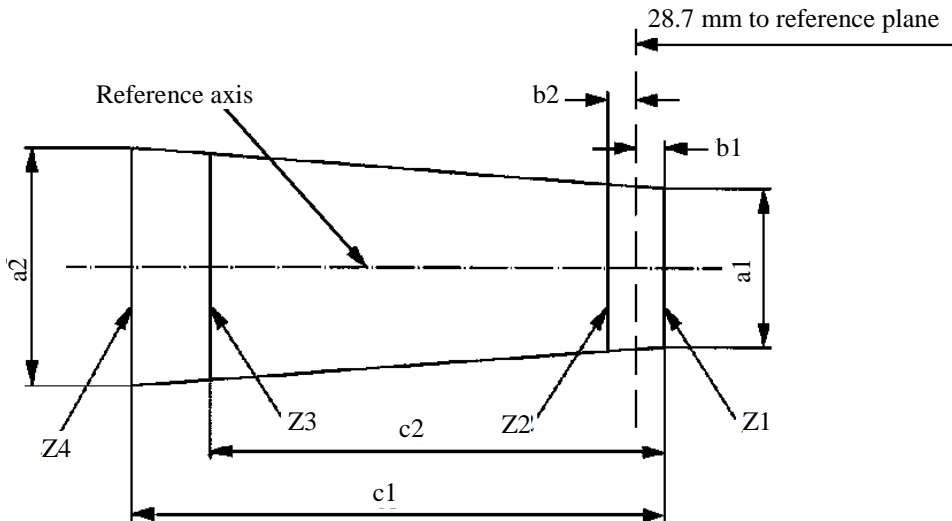

| | a_1 | a_2 | b_1 | b_2 | c_1 | c_2 |
|------|-----------|-----------|-------|-------|-------|-------|
| 12 V | $d + 0.4$ | $d + 0.8$ | 0.35 | | 6.6 | 5.7 |

d = diameter of filament

The filament position is checked solely in directions A and B as shown on sheet HIR2/1.

The ends of the filament as defined on sheet HIR2/2 footnote 10/ shall lie between lines Z_1 and Z_2 and between lines Z_3 and Z_4 .

The drawings are intended only to illustrate the essential dimensions (in mm) of the filament light source.

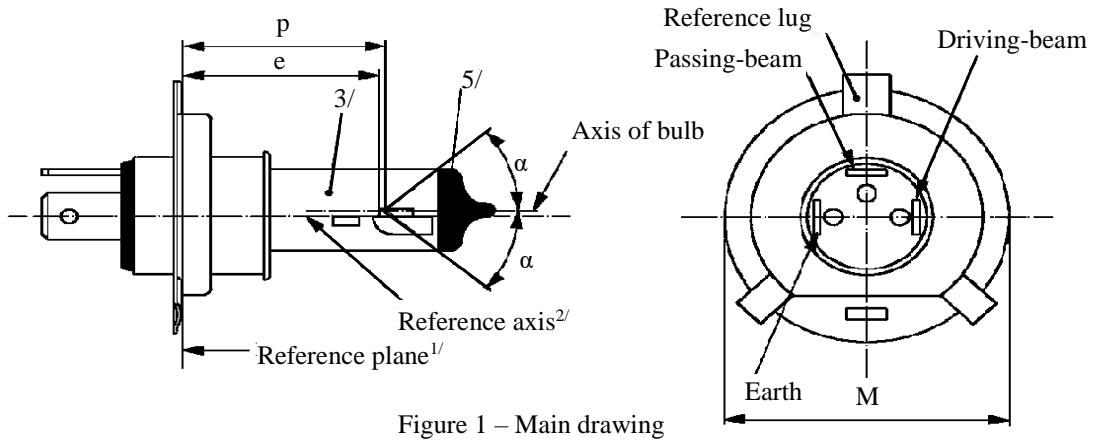

Figure 1 – Main drawing

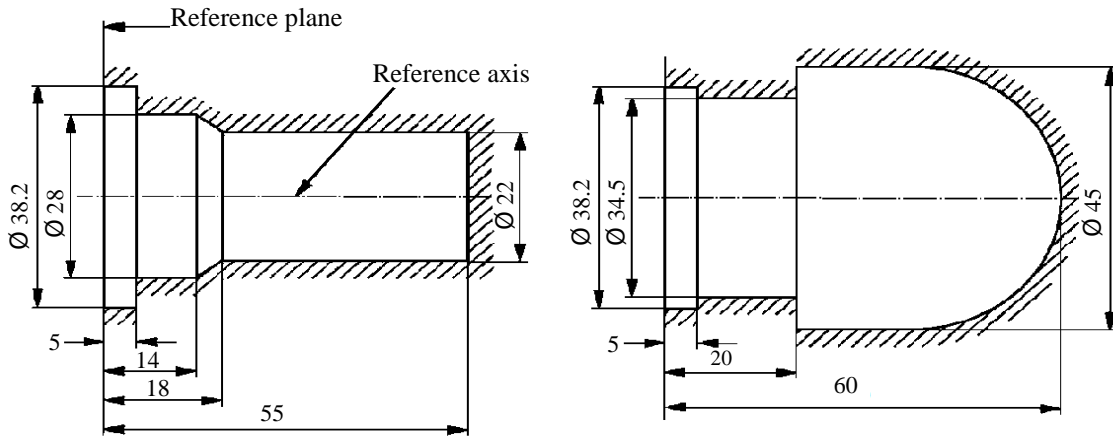

Figure 2 Maximum filament light source outlines^{4/} Figure 3

- ^{1/} The reference plane is the plane formed by the seating points of the three lugs of the cap ring.
- ^{2/} The reference axis is perpendicular to the reference plane and passes through the centre of the circle of diameter "M".
- ^{3/} The colour of the light emitted shall be white or selective-yellow.
- ^{4/} The bulb and supports shall not exceed the envelope as in Figure 2. However, where a selective-yellow outer bulb is used the bulb and supports shall not exceed the envelope as in Figure 3.
- ^{5/} The obscuration shall extend at least as far as the cylindrical part of the bulb. It shall also overlap the internal shield when the latter is viewed in a direction perpendicular to the reference axis.

Category HS1

Sheet HS1/2

| Dimensions in mm | Filament light sources of normal production | | | | Standard filament light source | | |
|--|---|-----------------|------|------------------|--------------------------------|------------------|-----|
| | 6 V | | 12 V | | 12 V | | |
| e | 28.5 + 0.45 / -0.25 | | | | 28.5 + 0.20 / -0.00 | | |
| p | 28.95 | | | | 28.95 | | |
| α | max. 40° | | | | max. 40° | | |
| Cap PX43t in accordance with IEC Publication 60061 (sheet 7004-34-2) | | | | | | | |
| Electrical and photometric characteristics | | | | | | | |
| Rated values | Volts | 6 ^{6/} | | 12 ^{6/} | | 12 ^{6/} | |
| | Watts | 35 | 35 | 35 | 35 | 35 | 35 |
| Test voltage | Volts | 6.3 | | 13.2 | | 13.2 | |
| Objective values | Watts | 35 | 35 | 35 | 35 | 35 | 35 |
| | ± % | 5 | | | | 5 | |
| | Luminous flux | 700 | 440 | 825 | 525 | | |
| | ± % | 15 | | | | | |
| Measuring flux ^{7/} lm | | - | | - | 450 | | |
| Reference luminous flux at approximately | | | | 12 V | | 700 | 450 |
| | | | | 13.2 V | | 825 | 525 |

^{6/} The values indicated in the left hand column relate to the driving-beam. Those indicated in the right-hand column relate to the passing-beam.

^{7/} Measuring luminous flux according to the provisions for filament light sources with an internal shield to produce the cut-off.

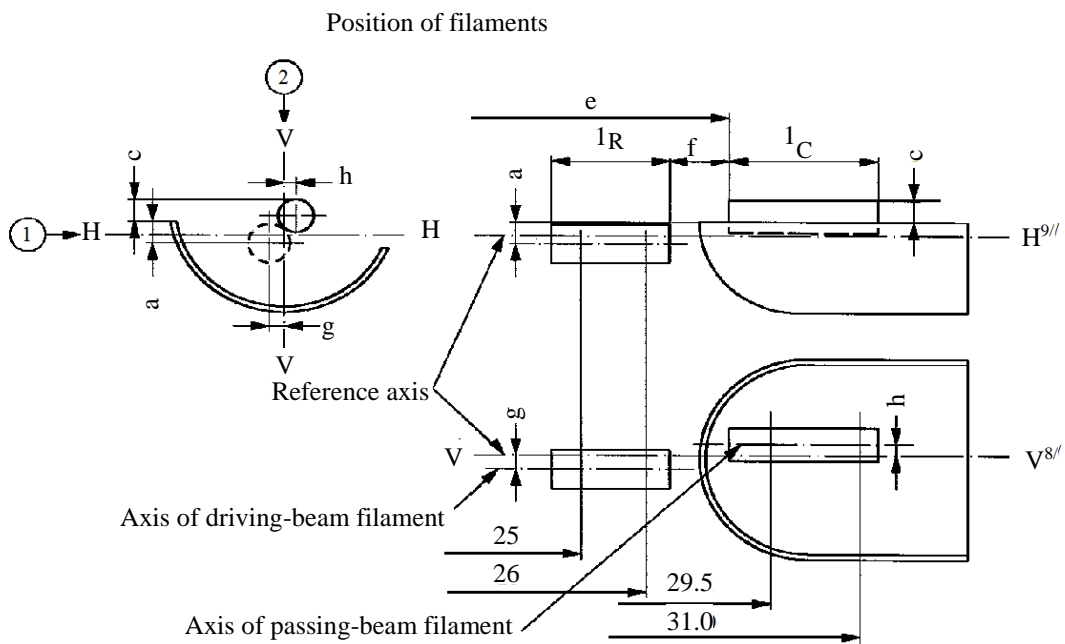
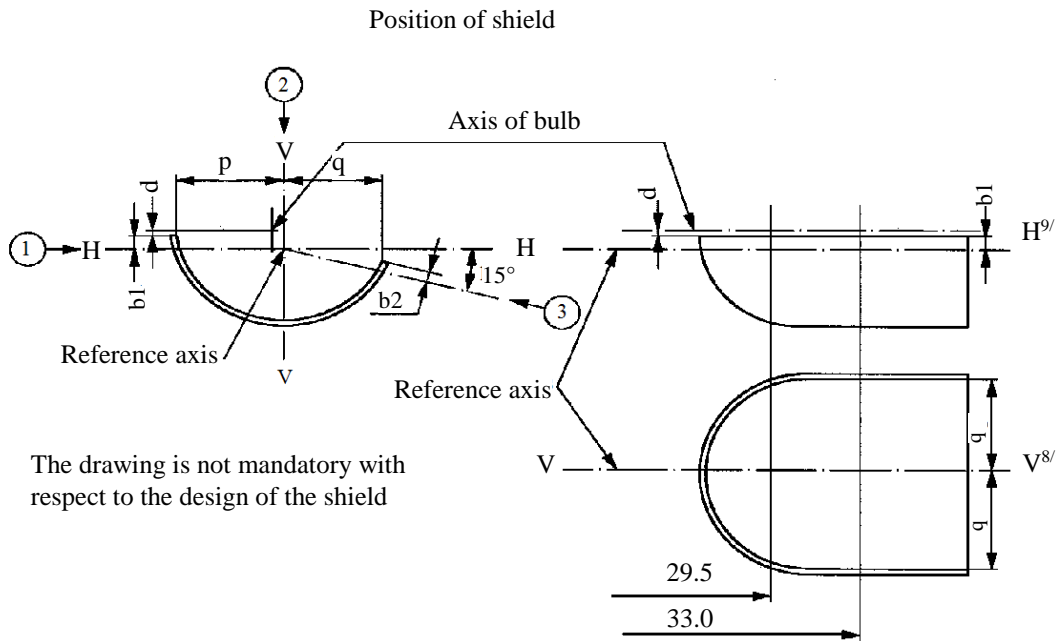

Category HS1

Sheet HS1/4

Table of the dimensions (in mm) referred to in the drawings on sheet HS1/3

| Reference* | | Dimensions** | | Tolerance | | |
|------------------------------------|------|------------------------------------|------|---|------|--------------------------------|
| | | | | Filament light sources of normal production | | Standard filament light source |
| 6 V | 12 V | 6 V | 12 V | 6 V | 12 V | 12 V |
| a/26 | | 0.8 | | ±0.35 | | ±0.20 |
| a/25 | | 0.8 | | ±0.55 | | ±0.20 |
| b1/29.5 | | 0 | | ±0.35 | | ±0.20 |
| b1/33 | | b1/29.5 mv | | ±0.35 | | ±0.15 |
| b2/29.5 | | 0 | | ±0.35 | | ±0.20 |
| b2/33 | | b2/29.5 mv | | ±0.35 | | ±0.15 |
| c/29.5 | | 0.6 | | ±0.35 | | ±0.20 |
| c/31 | | c/29.5 mv | | ±0.30 | | ±0.15 |
| d | | min. 0.1 / max. 1.5 | | - | | - |
| e ^{13/} | | 28.5 | | +0.45 / -0.25 | | +0.20 / -0.00 |
| f ^{11/, 12/, 13/} | | 1.7 | | +0.50 / -0.30 | | +0.30 / -0.10 |
| g/26 | | 0 | | ±0.50 | | ±0.30 |
| g/25 | | 0 | | ±0.70 | | ±0.30 |
| h/29.5 | | 0 | | ±0.50 | | ±0.30 |
| h/31 | | h/29.5 mv | | ±0.30 | | ±0.20 |
| l _R ^{11/, 14/} | | 3.5 | 4.0 | ±0.80 | | ±0.40 |
| l _C ^{11/, 12/} | | 3.3 | 4.5 | ±0.80 | | ±0.35 |
| p/33 | | Depends on the shape of the shield | | - | | - |
| q/33 | | (p+q)/2 | | ±0.60 | | ±0.30 |

* ".../26" means dimension to be measured at the distance from the reference plane indicated in mm after the stroke.

** "29.5 mv" means the value measured at a distance of 29.5 mm from the reference plane.

- ^{8/} Plane V-V is the plane perpendicular to the reference plane and passing through the reference axis and through the intersection of the circle of diameter "M" with the axis of the reference lug.
- ^{9/} Plane H-H is the plane perpendicular to both the reference plane and plane V-V and passing through the reference axis.
- ^{10/} (Blank).
- ^{11/} The end turns of the filament are defined as being the first luminous turn and the last luminous turn that are at substantially the correct helix angle. For coiled-coil filaments, the turns are defined by the envelope of the primary coil.
- ^{12/} For the passing-beam filament, the points to be measured are the intersections, seen in direction 1, of the lateral edge of the shield with the outside of the end turns defined under footnote 11/.
- ^{13/} "e" denotes the distance from the reference plane to the beginning of the passing-beam filament as defined above.
- ^{14/} For the driving-beam filament the points to be measured are the intersections, seen in direction 1, of a plane, parallel to plane H-H and situated at a distance of 0.8 mm below it, with the end turns defined under footnote 11/.

Additional explanations to sheet HS1/3

The dimensions below are measured in three directions:

- 1 For dimensions a, b1, c, d, e, f, I_R and I_C;
- 2 For dimensions g, h, p and q;
- 3 For dimension b2.

Dimensions p and q are measured in planes parallel to and 33 mm away from the reference plane.

Dimensions b1 and b2 are measured in planes parallel to and 29.5 mm and 33 mm away from the reference plane.

Dimensions a and g are measured in planes parallel to and 25.0 mm and 26.0 mm away from the reference plane.

Dimensions c and h are measured in planes parallel to and 29.5 mm and 31 mm away from the reference plane.

Note: For the method of measurement, see Appendix E of IEC Publication 60809.

The drawings are intended only to illustrate the essential dimensions (in mm) of the filament light source.

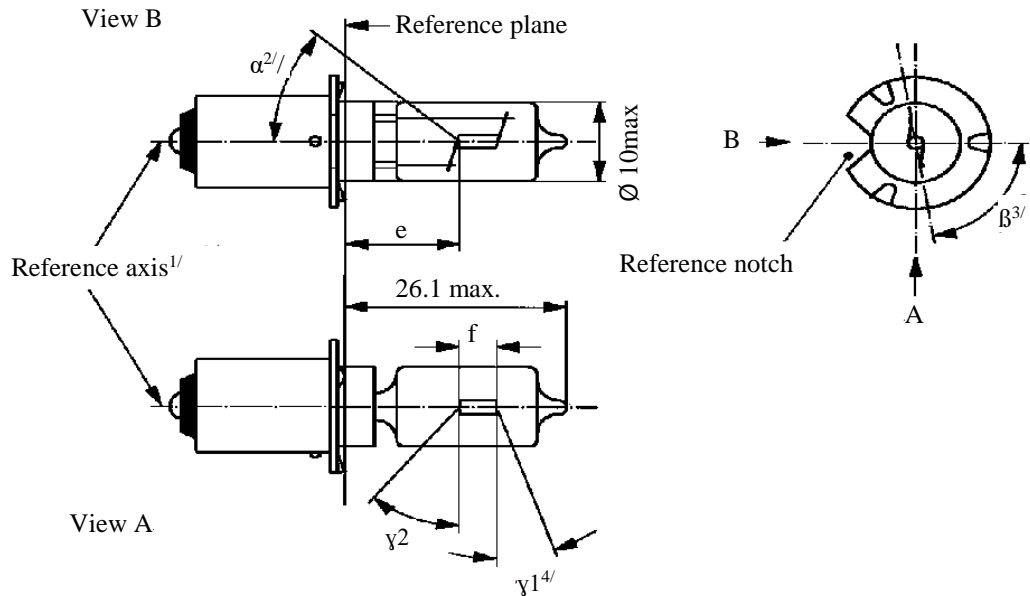

Filament position

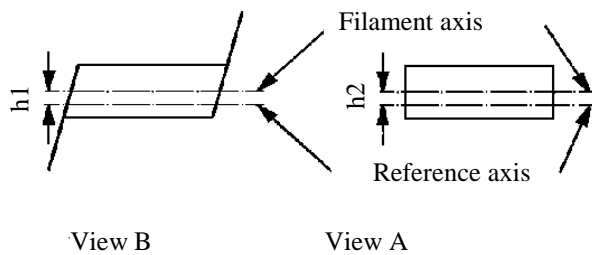

- ^{1/} The reference axis is perpendicular to the reference plane and passes through the intersection of this plane with the axis of the cap ring.
- ^{2/} All parts which may obscure the light or may influence the light beam shall lie within angle α .
- ^{3/} Angle β denotes the position of the plane through the inner leads with reference to the reference notch.
- ^{4/} In the area between the outer legs of the angles $\gamma 1$ and $\gamma 2$, the bulb shall have no optically distorting areas and the curvature of the bulb shall have a radius not less than 50 per cent of the actual bulb diameter.

| Dimensions in mm | | Filament light sources of normal production | | | Standard filament light source |
|--|---------------|---|--------------------|------|--------------------------------|
| | | Min. | Nom. | Max. | |
| e | | | 11.0 ^{5/} | | 11.0 ± 0.15 |
| f ^{6/} | 6 V | 1.5 | 2.5 | 3.0 | 2.5 ± 0.15 |
| | 12 V | 2.0 | 3.0 | 4.0 | |
| h1, h2 | | | ^{5/} | | 0 ± 0.15 |
| α ^{2/} | | | | 40° | |
| β ^{3/} | | 75° | 90° | 105° | 90° ± 5° |
| γ 1 ^{4/} | | 15° | | | 15° min. |
| γ 2 ^{4/} | | 40° | | | 40° min. |
| Cap PX13.5s in accordance with IEC Publication 60061 (sheet 7004-35-2) | | | | | |
| Electrical and photometric characteristics | | | | | |
| Rated values | Volts | 6 | 12 | 6 | |
| | Watts | 15 | | | 15 |
| Test voltage | Volts | 6.75 | 13.5 | 6.75 | |
| Objective values | Watts | 15 ± 6 % | | | 15 ± 6 % |
| | Luminous flux | 320 ± 15 % | | | |
| Reference luminous flux: 320 lm at approximately 6.75 V | | | | | |

^{5/} To be checked by means of the "Box system", sheet HS2/3.

^{6/} In order to avoid rapid filament failure, the supply voltage shall not exceed 8.5 V for 6 V filament light sources and 15 V for 12 V types.

Screen projection requirements

This test is used to determine, by checking whether the filament light source complies with the requirements by checking whether the filament light source is correctly positioned relative to the reference axis and reference plane.

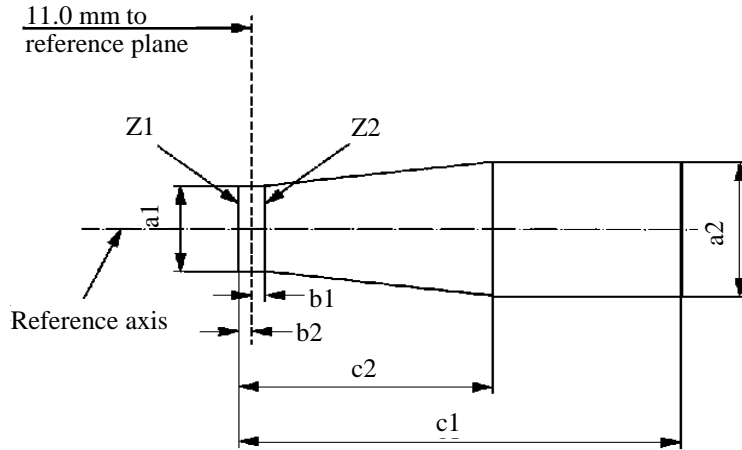

| Reference | $a1$ | $a2$ | $b1$ | $b2$ | $c1$ (6 V) | $c1$ (12 V) | $c2$ |
|-----------|-----------|-----------|------|------|------------|-------------|------|
| Dimension | $d + 1.0$ | $d + 1.4$ | 0.25 | 0.25 | 4.0 | 4.5 | 1.75 |

d = actual filament diameter

The filament shall lie entirely within the limits shown.

The beginning of the filament shall lie between the lines Z1 and Z2.

The drawings are intended only to illustrate the essential dimensions (in mm) of the filament light source.

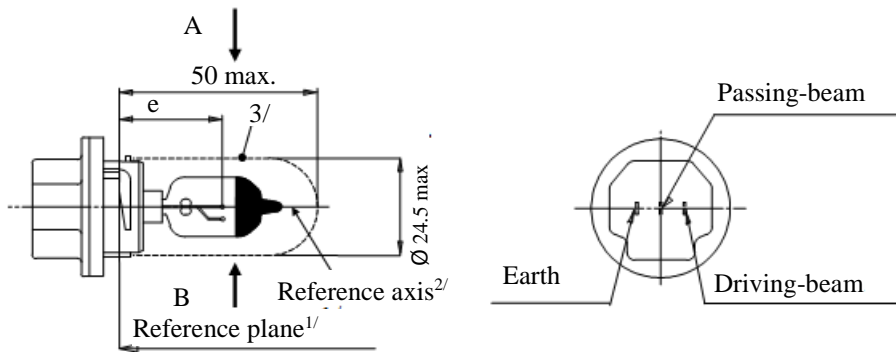

Figure 1 – Main drawing

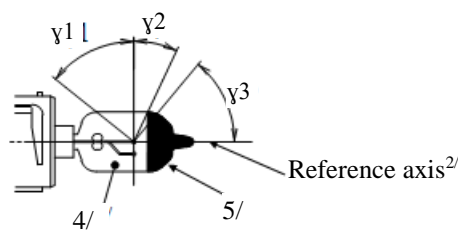
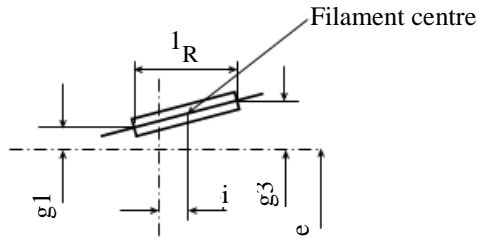

Figure 2 - Distorsion free area^{4/} and black top^{5/}

- ^{1/} The reference plane is defined by the three ramp inside surface.
- ^{2/} The reference axis is perpendicular to the reference plane and passing through the centre of the 23 mm cap diameter.
- ^{3/} Glass bulb and supports shall not exceed the envelope as indicated in Figure 1. The envelope is concentric to the reference axis.
- ^{4/} Glass bulb shall be optically distortion free within the angles γ_1 and γ_2 . This requirement applies to the whole bulb circumference within the angles γ_1 and γ_2 .
- ^{5/} The obscuration shall extend at least to angle γ_3 and shall extend at least to the cylindrical part of the bulb on the whole top circumference.

View B of driving-beam filament



View A of passing-beam filament

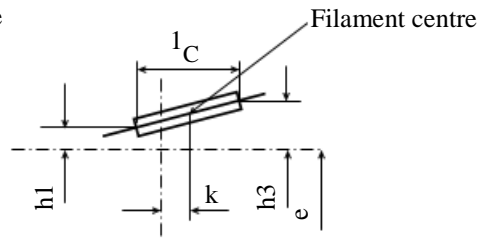

Top view of driving-beam filament

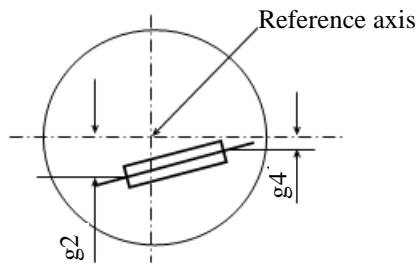

Top view of passing-beam filament

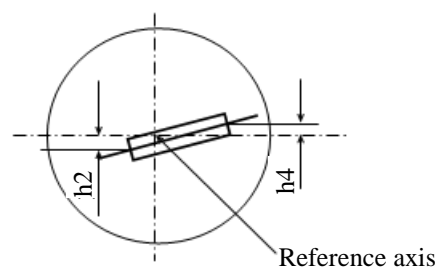

Figure 3 – Filament position and dimensions

| Dimensions in mm | | Filament light sources of normal production | | Standard filament light source | | |
|--|---------------|---|---------|--------------------------------|---------|---------|
| | | 12 V | | 12 V | | |
| e | 26 | ^{6/} | | ±0.15 | | |
| l _C ^{7/} | 4.6 | | | ±0.3 | | |
| k | 0 | | | ±0.2 | | |
| h1, h3 | 0 | | | ±0.15 | | |
| h2, h4 | 0 | | | ±0.20 | | |
| l _R ^{7/} | 4.6 | | | ±0.3 | | |
| j | 0 | | | ±0.2 | | |
| g1, g3 | 0 | | | ±0.30 | | |
| g2, g4 | 2.5 | | | ±0.40 | | |
| γ1 | 50° min. | - | | - | | |
| γ2 | 23° min. | - | | - | | |
| γ3 | 50° min. | - | | - | | |
| Cap P23t in accordance with IEC Publication 60061 (sheet 7004-138-2) | | | | | | |
| Electrical and photometric characteristics | | | | | | |
| Rated values | Voltage | V | 12 | | 12 | |
| | Wattage | W | 35 | 30 | 35 | 30 |
| Test voltage | | V | 13.2 | | 13.2 | |
| Objective values | Wattage | W | 40 max. | 37 max. | 40 max. | 37 max. |
| | Luminous flux | lm | 620 | 515 | | |
| | | ± % | 15 | 15 | | |
| Reference luminous at approximately | | | | 12 V | 460 | 380 |
| | | | | 13.2 V | 620 | 515 |

^{6/} To be checked by means of a "Box system". Sheet HS5/4.

^{7/} The positions of the first and the last turn of the filament are defined by the intersections of the outside of the first and the outside of the last light-emitting turn, respectively, with the plane parallel to and 26 mm distant from the reference plane.

Screen projection requirement

This test is used to determine whether a filament light source complies with the requirements by checking whether:

- (a) The passing-beam filament is correctly positioned relative to the reference axis and the reference plane; and whether
- (b) The driving-beam filament is correctly positioned relative to the passing-beam filament.

Side elevation

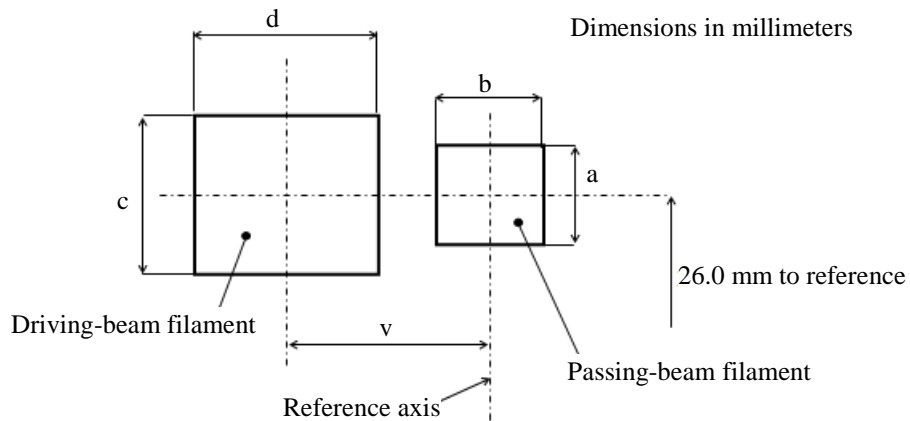

| Reference | a | b | c | d | v |
|------------|--------|--------|--------|--------|-----|
| Dimensions | d1+0.6 | d1+0.8 | d2+1.2 | d2+1.6 | 2.5 |

d1 : Diameter of the passing-beam filament
 d2 : Diameter of the driving-beam filament

Front elevation

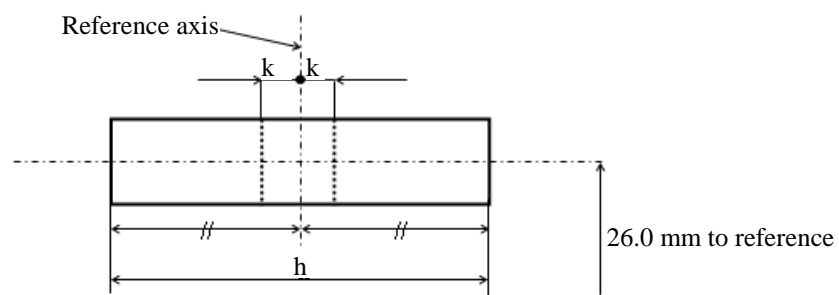

| Reference | h | k |
|------------|-----|-----|
| Dimensions | 6.0 | 0.5 |

The filaments shall lie entirely within the limits shown.

The centre of the filament shall lie within the limits of dimension k.

The drawings are intended only to illustrate the essential dimensions (in mm) of the filament light source.

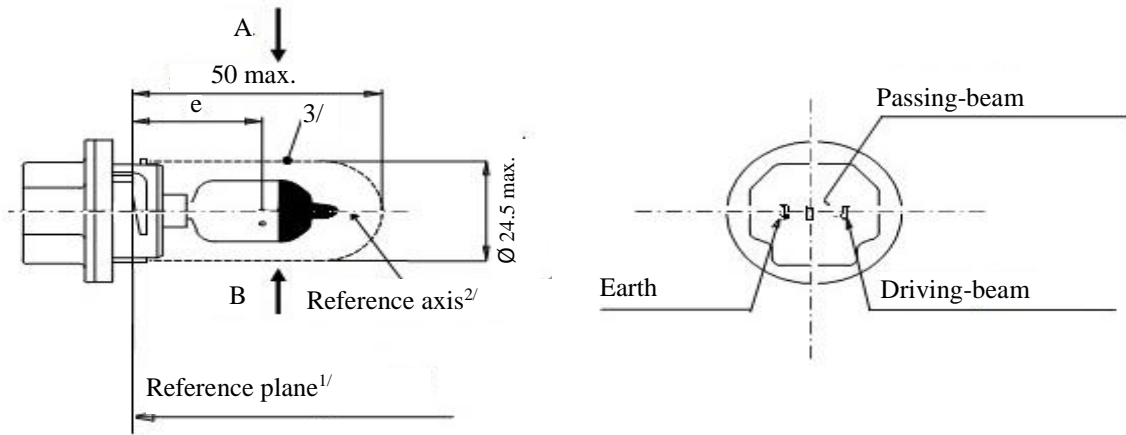

Figure 1 – Main drawing

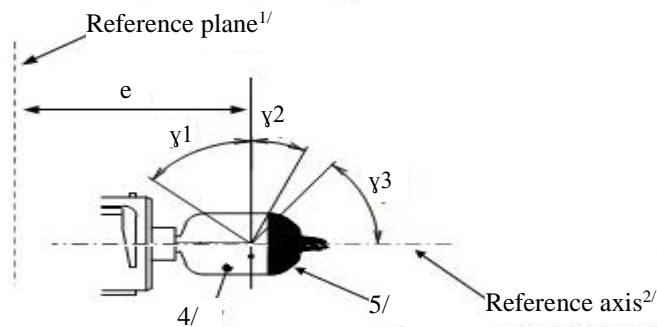

Figure 2 - Distorsion free area^{4/} and black top^{5/}

- ^{1/} The reference plane is defined by three ramps inside surface.
- ^{2/} The reference axis is perpendicular to the reference plane and passing through the centre of the 23 mm cap diameter.
- ^{3/} Glass bulb and supports shall not exceed the envelope as indicated in Figure 1. The envelope is concentric to the reference axis.
- ^{4/} Glass bulb shall be optically distortion free within the angles γ_1 and γ_2 . This requirement applies to the whole bulb circumference within the angles γ_1 and γ_2 .
- ^{5/} The obscuration shall extend at least to angle γ_3 and shall extend at least to the cylindrical part of the bulb on the whole top circumference.

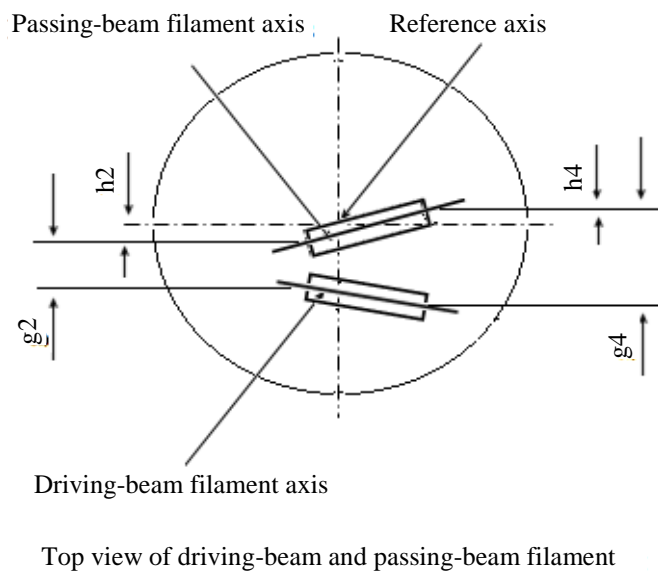
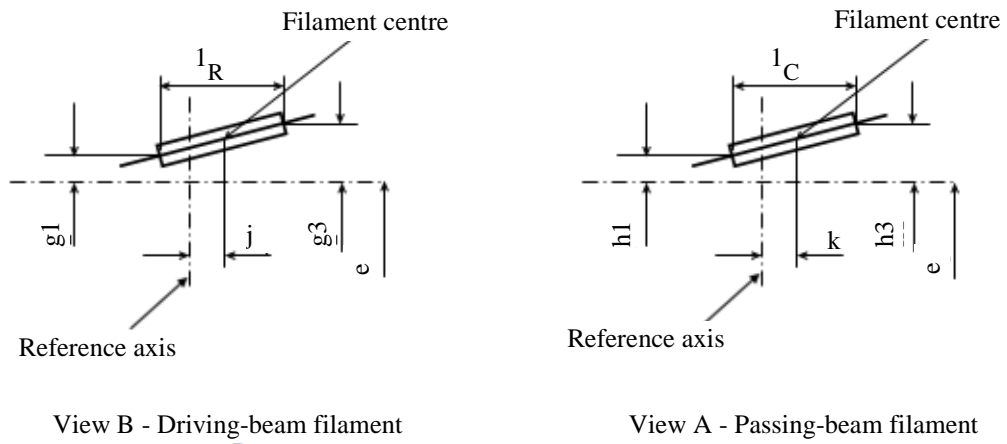

Figure 3 – Filament position and dimensions

| <i>Dimensions in mm</i> | | <i>Filament light sources of normal production</i> | | <i>Standard filament light source</i> | | |
|--|---------------|--|------------------|---------------------------------------|------------------|---------|
| | | <i>12 V</i> | | <i>12 V</i> | | |
| e | 26 | - | | - | | |
| l _C ^{6/} | 4.6 | ±0.5 | | ±0.3 | | |
| k | 0 | ±0.4 | | ±0.2 | | |
| h1, h3 | 0 | ±0.3 | | ±0.15 | | |
| h2, h4 | 0 | ±0.4 | | ±0.2 | | |
| l _R ^{6/} | 4.6 | ±0.5 | | ±0.3 | | |
| j | 0 | ±0.6 | | ±0.3 | | |
| g1, g3 | 0 | ±0.6 | | ±0.3 | | |
| g2, g4 | 2.5 | ±0.4 | | ±0.2 | | |
| γ1 | 50° min. | - | | - | | |
| γ2 | 23° min. | - | | - | | |
| γ3 | 50° min. | - | | - | | |
| Cap PX23t in accordance with IEC Publication 60061 (sheet 7004-138A-1) | | | | | | |
| Electrical and photometric characteristics | | | | | | |
| Rated values | Voltage | V | 12 ^{7/} | | 12 ^{7/} | |
| | Wattage | W | 45 | 40 | 45 | 40 |
| Test voltage | | V | 13.2 | | 13.2 | |
| Objective Values | Wattage | W | 50 max. | 45 max. | 50 max. | 45 max. |
| | Luminous flux | lm | 750 | 640 | | |
| | | ± % | | 15 | 15 | |
| Reference luminous at approximately | | | 12 V | | 550 lm | 470 lm |
| | | | 13.2 V | | 750 lm | 640 lm |

^{6/} The positions of the first and the last turn of the filament are defined by the intersections of the outside of the first and the outside of the last light-emitting turn, respectively, with the plane parallel to and 26 mm distant from the reference plane.

^{7/} The values indicated in the left-hand columns relate to the driving-beam filament and those indicated in the right-hand columns to the passing-beam filament.

Category HS6

Sheet HS6/1

The drawings are intended only to illustrate the essential dimensions (in mm) of the filament light source.

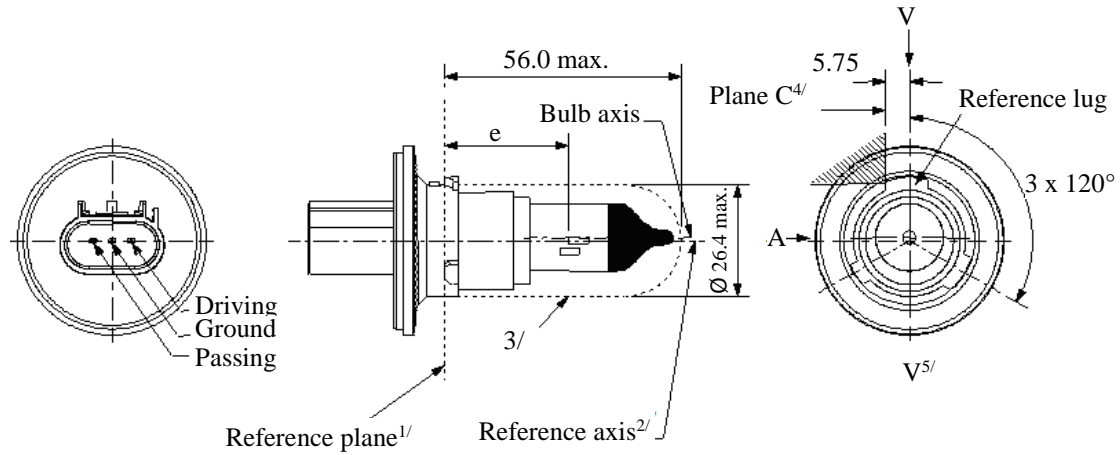

Figure 1 - Main drawings

- ^{1/} The reference plane is the plane formed by the underside of the three radiused tabs of the cap.
- ^{2/} The reference axis is perpendicular to the reference plane and crosses the intersection of the two perpendiculars as indicated in Figure 2 on sheet HS6/2.
- ^{3/} Glass bulb and supports shall not exceed the envelope as indicated. The envelope is concentric to the reference axis.
- ^{4/} The filament light source shall be rotated in the measuring holder until the reference lug contacts plane C of the holder.
- ^{5/} Plane V-V is the plane perpendicular to the reference plane passing through the reference axis and parallel to plane C.

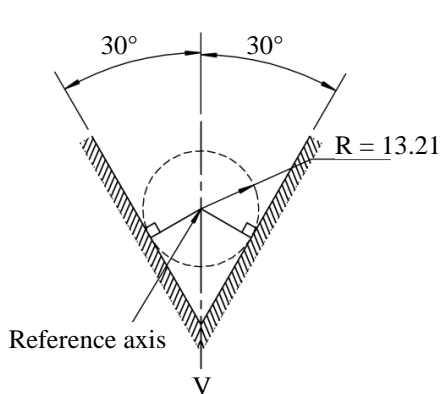

Figure 2 – Definition of reference axis^{2/}

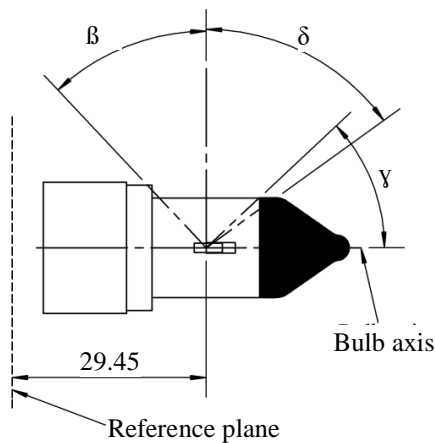

Figure 3 - Undistorted area^{6/} and opaque coating^{7/}

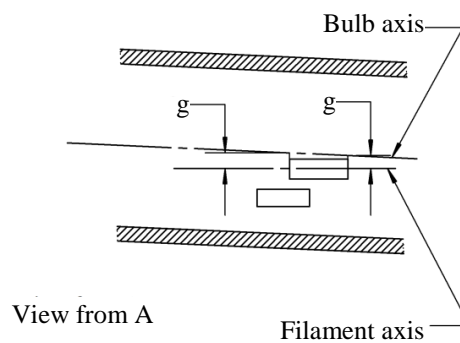
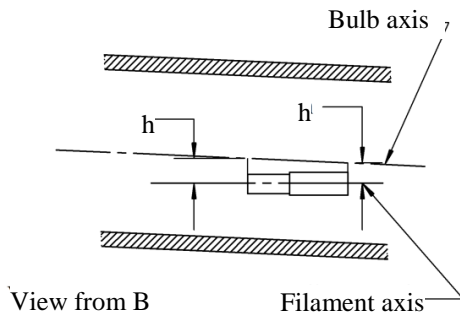

Figure 4 – Bulb offset^{8/}

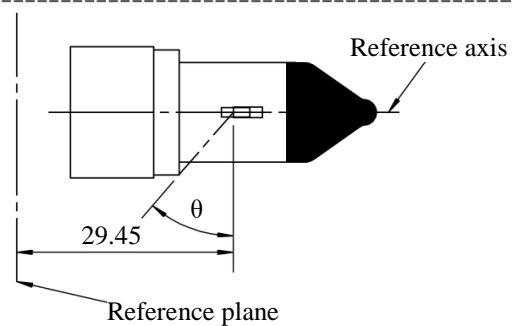

Figure 5 – Light blocking toward^{9/} cap

- ^{6/} Glass bulb shall be optically distortion-free axially and cylindrically within the angles β and δ . This requirement applies to the whole bulb circumference within the angles β and δ and does not need to be verified in the area covered by the opaque coating.
- ^{7/} The opaque coating shall extend at least to the cylindrical part of the bulb on the whole bulb top circumference. It shall moreover extend at least to a plane parallel to the reference plane where γ crosses the outer bulb surface as shown in Figure 3 (view in direction B as indicated on sheet HS6/1).
- ^{8/} Offset of passing-beam filament in relation to the bulb axis is measured in two planes parallel to the reference plane where the projection of the outside end turns nearest to and farthest from the reference plane crosses the passing-beam filament axis.
- ^{9/} Light shall be blocked over the cap end of the bulb extending to angle θ . This requirement applies in all directions around the reference axis.

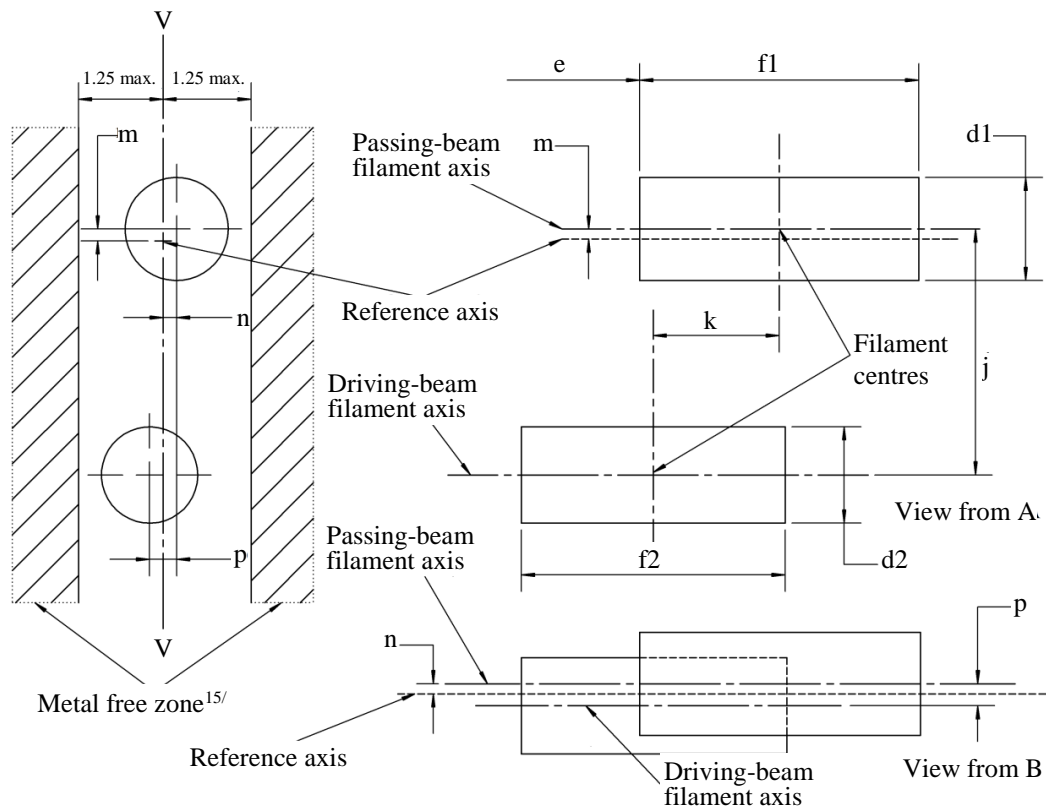

Figure 6 – Position and dimensions of filaments^{10/, 11/, 12/, 13/, 14/}

^{10/} Dimensions j, k and p are measured from the centre of the passing-beam filament to the centre of the driving-beam filament.

^{11/} Dimensions m and n are measured from the reference axis to the centre of the passing-beam filament.

^{12/} Both filaments axis are to be held within a 2° tilt with respect to the reference axis about the centre of the respective filament.

^{13/} Note concerning the filament diameters: for the same manufacturer, the design filament diameter of standard (étalon) filament light source and filament light source of normal production shall be the same.

^{14/} For both the driving-beam and the passing-beam filament distortion shall not exceed ±5 per cent of filament diameter from a cylinder.

^{15/} The metal free zone limits the location of lead wires within the optical path. No metal parts shall be located in the shaded area as seen in Figure 6.

| Dimensions in mm | | Tolerance | | | |
|---|---------------|---|------------|--------------------------------|---------|
| | | Filament light sources of normal production | | Standard filament light source | |
| d1 ^{13/, 17/} | 1.4 max. | - | | - | |
| d2 ^{13/, 17/} | 1.4 max. | - | | - | |
| e ^{16/} | 29.45 | ±0.20 | | ±0.10 | |
| f1 ^{16/} | 4.4 | ±0.50 | | ±0.25 | |
| f2 ^{16/} | 4.4 | ±0.50 | | ±0.25 | |
| g ^{8/, 17/} | 0.5 d1 | ±0.50 | | ±0.30 | |
| h ^{8/} | 0 | ±0.40 | | ±0.20 | |
| j ^{10/} | 2.5 | ±0.30 | | ±0.20 | |
| k ^{10/} | 2.0 | ±0.20 | | ±0.10 | |
| m ^{11/} | 0 | ±0.24 | | ±0.20 | |
| n ^{11/} | 0 | ±0.24 | | ±0.20 | |
| p ^{10/} | 0 | ±0.30 | | ±0.20 | |
| β | 42° min. | - | | - | |
| δ | 52° min. | - | | - | |
| γ | 43° | +0° / -5° | | +0° / -5° | |
| θ ^{9/} | 41° | ±4° | | ±4° | |
| Cap PX26.4t in accordance with IEC Publication 60061 (sheet 7004-128-3) | | | | | |
| Electrical and photometric characteristics ^{18/} | | | | | |
| Rated values | Volts | 12 | | 12 | |
| | Watts | 40 | 35 | 40 | 35 |
| Test voltage | Volts | 13.2 | | 13.2 | |
| Objective values | Watts | 45 max. | 40 max. | 45 max. | 40 max. |
| | Luminous flux | 900 ± 15 % | 600 ± 15 % | | |
| Reference luminous flux at approximately | | 12 V | | 630/420 | |
| | | 13.2 V | | 900/600 | |

^{16/} The ends of the filament are defined as the points where, when the viewing direction is direction A as shown on sheet HS6/1, the projection of the outside of the end turns crosses the filament axis.

^{17/} d1 is the actual diameter of the passing-beam filament.

d2 is the actual diameter of the driving-beam filament.

^{18/} The values indicated in the left-hand columns relate to the driving-beam filament and those in the right-hand columns to the passing-beam filament.

The drawings are intended only to illustrate the essential dimensions (in mm) of the filament light source.

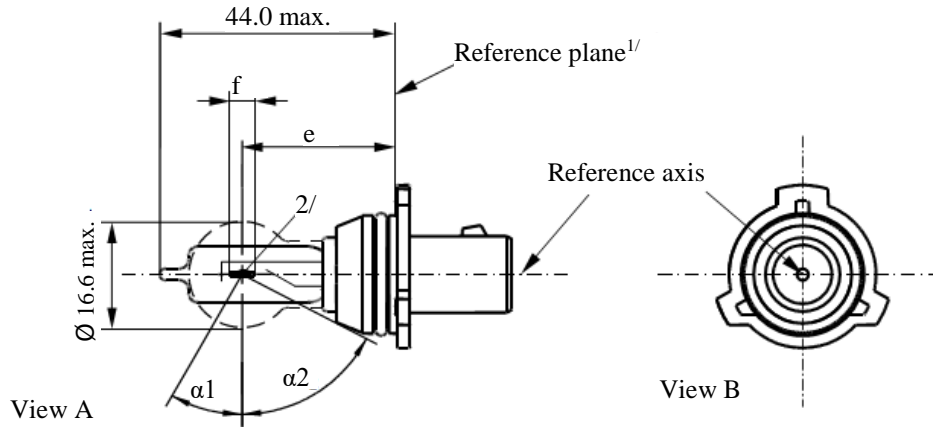

Figure 1 – Main drawing P13W

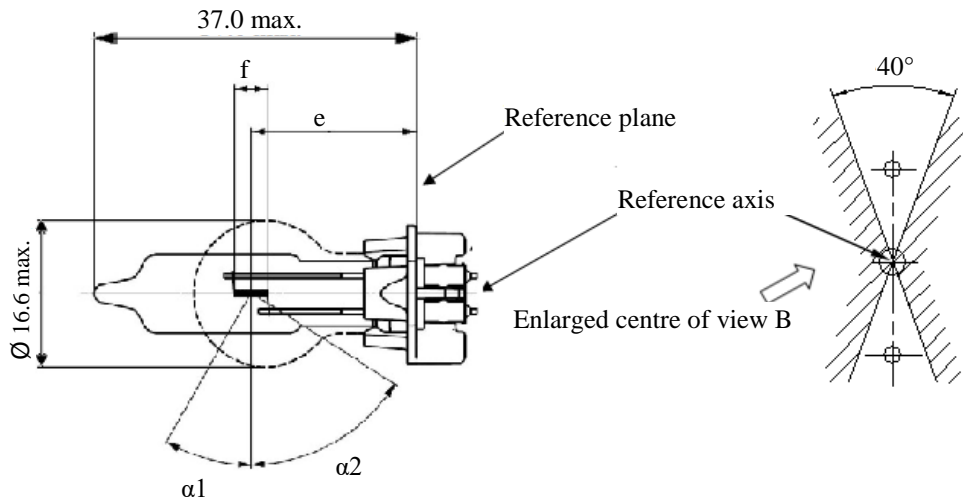

Figure 2 – Metal free zone^{3/}

Figure 3 – Main drawing PW13W

^{1/} The reference plane is defined by the meeting points of the cap-holder fit.

^{2/} No actual filament diameter restrictions apply but the objective is $d_{max} = 1.0$ mm.

^{3/} No opaque parts other than filament turns shall be located in the shaded area indicated in Figure 2. This applies to the rotational body within the angles $\alpha_1 + \alpha_2$.

| <i>Dimensions in mm</i> | | <i>Filament light sources of normal production</i> | | <i>Standard filament light source</i> |
|---|------------------|---|---------------|---------------------------------------|
| e ^{5/} | P13W | 25.0 ^{4/} | | 25.0 ± 0.25 |
| | PW13W | 19.25 ^{4/} | | 19.25 ± 0.25 |
| f ^{5/} | | 4.3 ^{4/} | | 4.3 ± 0.25 |
| α_1 ^{6/} | | 30.0° min. | | 30.0° min. |
| α_2 ^{6/} | | 58.0° min. | | 58.0° min. |
| P13W | Cap PG18.5d-1 | in accordance with IEC Publication 60061 (sheet 7004-147-1) | | |
| PW13W | Cap WP3.3x14.5-7 | in accordance with IEC Publication 60061 (sheet 7004-164-2) | | |
| Electrical and photometric characteristics | | | | |
| Rated values | Voltage | V | 12 | 12 |
| | Wattage | W | 13 | 13 |
| Test voltage | | V | 13.5 | 13.5 |
| Objective values | Wattage | W | 19 max. | 19 max. |
| | Luminous flux | lm | 250 | |
| | | ± | +15 % / -20 % | |
| Reference luminous flux at approximately 13.5 V | | | | 250 lm |

^{4/} To be checked by means of a "Box system"; sheet P13W/3.

^{5/} The ends of the filament are defined as the points where, when the viewing direction is perpendicular to the plane through the filament lead-in wires, the projection of the outside of the end turns crosses the filament axis.

^{6/} No part of the cap beyond the reference plane shall interfere with angle α_2 as shown in Figure 1 on sheet P13W/1. The bulb shall be optically distortion free within the angles $\alpha_1 + \alpha_2$. These requirements apply to the whole bulb circumference.

Screen projection requirements

This test is used to determine, by checking whether the filament is correctly positioned relative to the reference axis and reference plane, whether a filament light source complies with the requirements.

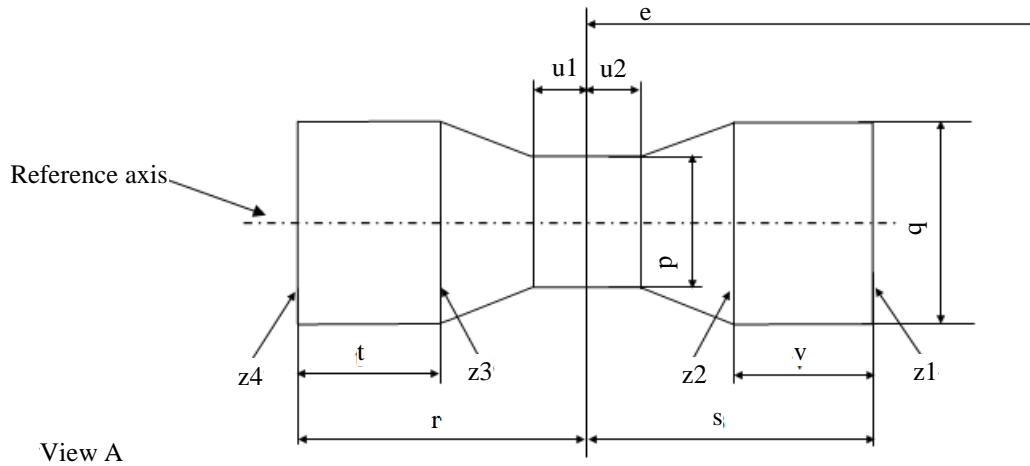

| | <i>p</i> | <i>q</i> | <i>u1,u2</i> | <i>r,s</i> | <i>t,v</i> |
|---|----------|----------|--------------|------------|------------|
| Filament light sources of normal production | 1.7 | 1.9 | 0.3 | 2.6 | 0.9 |
| Standard filament light sources | 1.5 | 1.7 | 0.25 | 2.45 | 0.6 |

The filament position is checked in two mutually perpendicular planes, one of them being the plane through the lead-in wires.

The ends of the filament as defined on sheet P13W/2, footnote 4/, shall lie between Z1 and Z2 and between the lines Z3 and Z4.

The filament shall lie entirely within the limits shown.

Categories P19W, PY19W, PR19W, PS19W, PSY19W, PSR19W, PW19W, PWY19W and PWR19W

The drawings are intended only to illustrate the essential dimensions (in mm) of the filament light source.

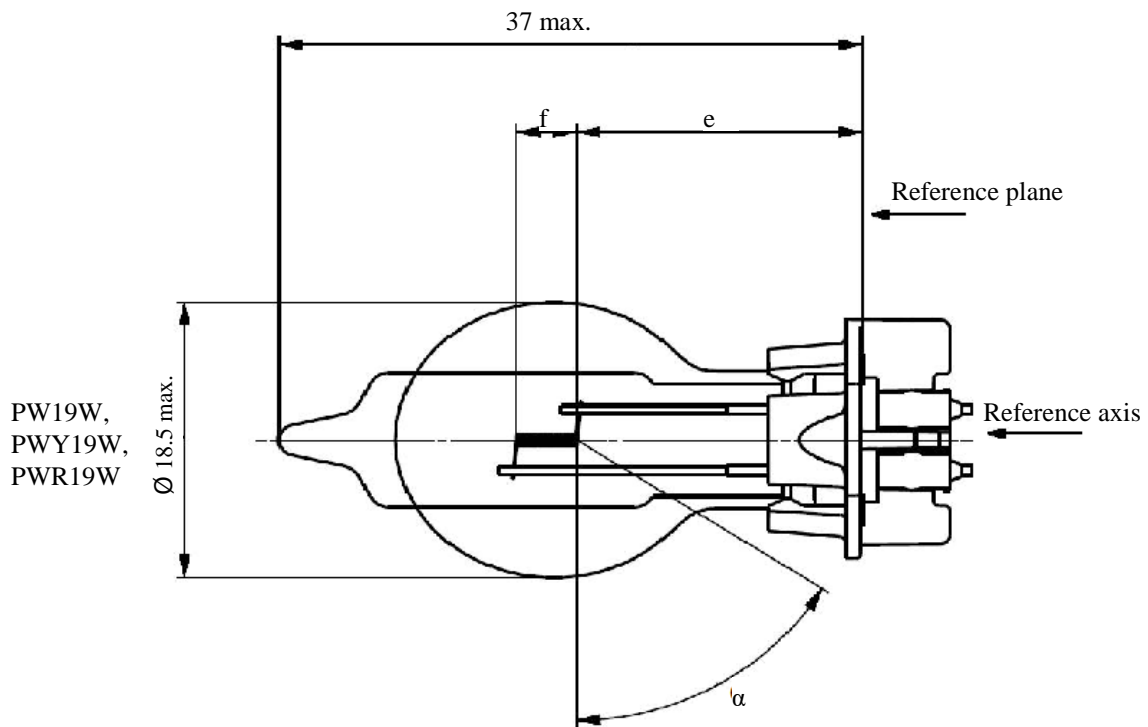
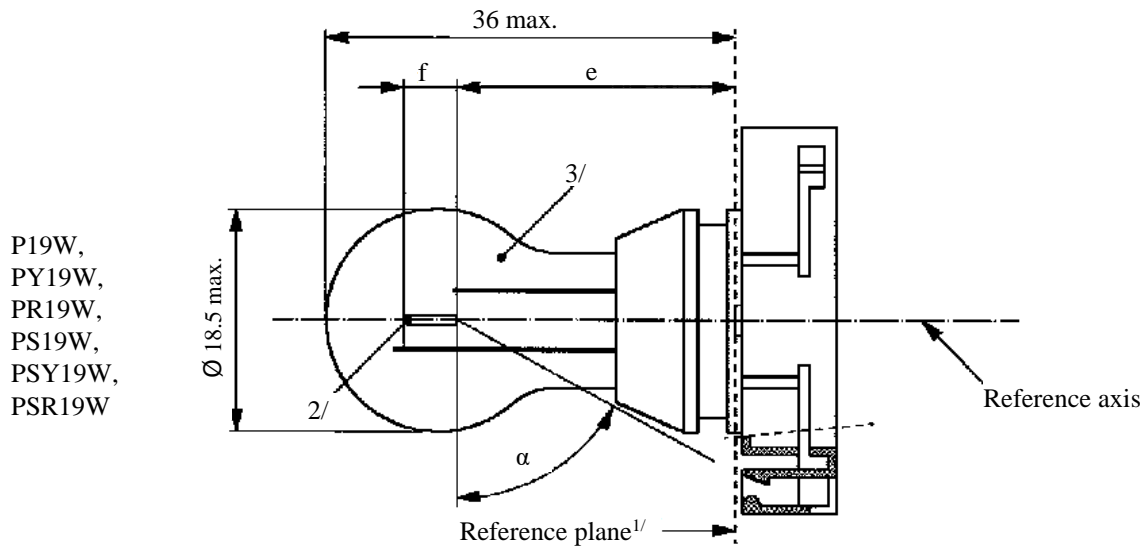

- ^{1/} The reference plane is defined by the meeting points of the cap-holder fit.
- ^{2/} No actual filament diameter restrictions apply but the objective is $d \text{ max.} = 1.1 \text{ mm}$.
- ^{3/} The light emitted from normal production filament light sources shall be white for categories P19W, PS19W and PW19W; amber for categories PY19W, PSY19W and PWY19W; red for categories PR19W, PSR19W and PWR19W (see also footnote 8/).

Sheet P19W/2

Categories P19W, PY19W, PR19W, PS19W, PSY19W, PSR19W, PW19W, PWY19W and PWR19W

| Dimensions in mm ^{4/} | | Filament light sources of normal production | | | Standard filament light source ^{8/} |
|---|---|---|------------|------|--|
| | | Min. | Nom. | Max. | |
| e ^{5/, 6/} | P19W, PS19W, PY19W, PSY19W, PR19W, PSR19W | | 24.0 | | 24.0 |
| | PW19W, PWY19W, PWR19W | | 18.1 | | 18.1 |
| f ^{5/, 6/} | | | 4.0 | | 4.0 ± 0.2 |
| α ^{7/} | | 58° | | | 58° min. |
| P19W | Cap PGU20-1 | in accordance with IEC Publication 60061 (sheet 7004-127-2) | | | |
| PY19W | Cap PGU20-2 | | | | |
| PR19W | Cap PGU20-5 | | | | |
| PS19W | Cap PG20-1 | | | | |
| PSY19W | Cap PG20-2 | | | | |
| PSR19W | Cap PG20-5 | | | | |
| PW19W | Cap WP3.3x14.5-1 | in accordance with IEC Publication 60061 (sheet 7004-164-2) | | | |
| PWY19W | Cap WP3.3x14.5-2 | | | | |
| PWR19W | Cap WP3.3x14.5-5 | | | | |
| Electrical and photometric characteristics | | | | | |
| Rated values | Volts | | 12 | | 12 |
| | Watts | | 19 | | 19 |
| Test voltage | Volts | | 13.5 | | 13.5 |
| | Watts | | 20 max. | | 20 max. |
| Objective values | Luminous flux | P19W PS19W PW19W | 350 ± 15 % | | |
| | | PY19W PSY19W PWY19W | 215 ± 20 % | | |
| | | PR19W PSR19W PWR19W | 80 ± 20 % | | |
| Reference luminous flux at approximately 13.5 V | | | | | White: 350 lm Amber: 215 lm Red: 80 lm |

^{4/} For categories PS19W, PSY19W and PSR19W, dimensions may be checked with O-ring removed to assure the correct mounting during testing.

^{5/} The filament position is checked by means of a "Box system"; sheet P19W/3.

^{6/} The ends of the filament are defined as the points where, when the viewing direction is perpendicular to the plane through the filament lead-in wires as showed in the drawing on sheet P19W/1, the projection of the outside of the end turns crosses the filament axis.

^{7/} No part of the cap beyond the reference plane shall interfere with angle α. The bulb shall be optically distortion free within the angle 2α + 180°.

^{8/} The light emitted from standard filament light sources shall be white for categories P19W, PS19W and PW19W; white or amber for categories PY19W, PSY19W and PWY19W; white or red for categories PR19W, PSR19W and PWR19W.

Categories P19W, PY19W, PR19W, PS19W, PSY19W, PSR19W, PW19W, PWY19W and PWR19W

Screen projection requirements

This test is used to determine, by checking whether the filament is correctly positioned relative to the reference axis and reference plane, whether a filament light source complies with the requirements.

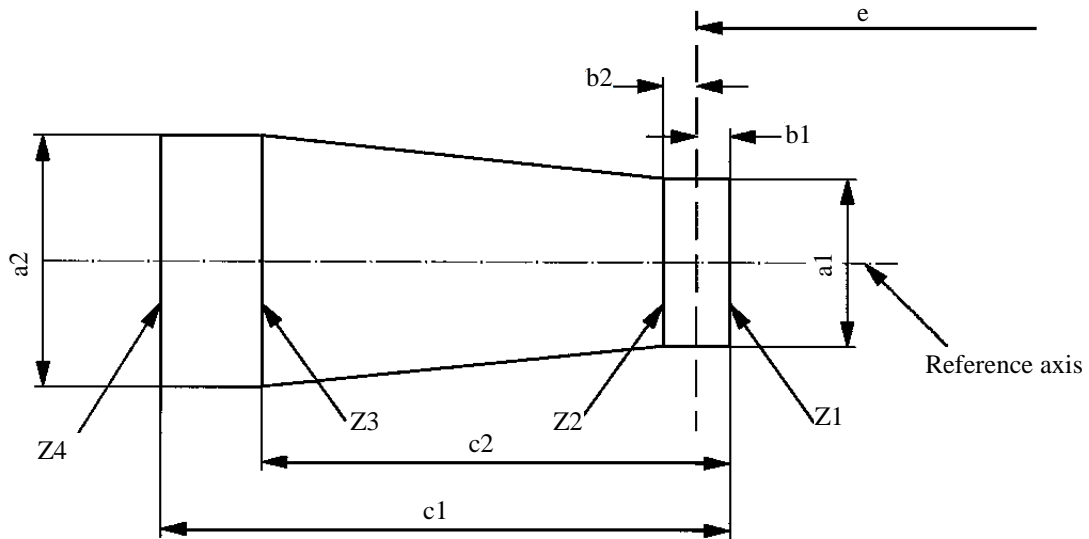

| <i>P19W, PY19W, PR19W, PS19W, PSY19W, PSR19W</i> | <i>a1</i> | <i>a2</i> | <i>b1, b2</i> | <i>c1</i> | <i>c2</i> |
|--|-----------|-----------|---------------|-----------|-----------|
| Filament light sources of normal production | 2.9 | 3.9 | 0.5 | 5.2 | 3.8 |
| Standard filament light sources | 1.5 | 1.7 | 0.25 | 4.7 | 3.8 |

| <i>PW19W, PWY19W and PWR19W</i> | <i>a1</i> | <i>a2</i> | <i>b1, b2</i> | <i>c1</i> | <i>c2</i> |
|---|-----------|-----------|---------------|-----------|-----------|
| Filament light sources of normal production | 2.5 | 2.5 | 0.4 | 5.2 | 3.8 |
| Standard filament light sources | 1.5 | 1.7 | 0.25 | 4.7 | 3.8 |

The filament position is checked in two mutually perpendicular planes, one of them being the plane through the lead-in wires.

The ends of the filament as defined on sheet P19W/2, footnote 6/, shall lie between Z1 and Z2 and between the lines Z3 and Z4.

The filament shall lie entirely within the limits shown.

Category P21W

Sheet P21W/1

The drawings are intended only to illustrate the essential dimensions (in mm) of the filament light source.

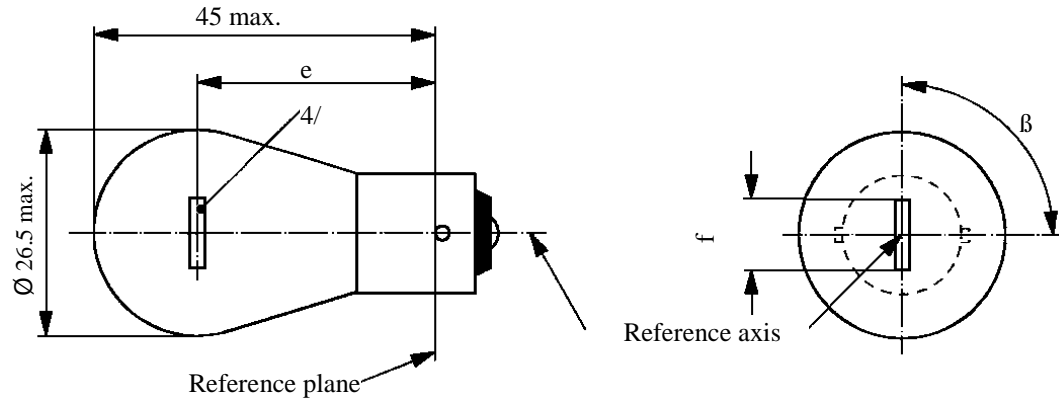

| Dimensions in mm | | Filament light sources of normal production | | | Standard filament light source |
|---|---------------|---|--------------------|---------------|--------------------------------|
| | | Min. | Nom. | Max. | |
| e | 6, 12 V | | 31.8 ^{3/} | | 31.8 ± 0.3 |
| | 24 V | 30.8 | 31.8 | 32.8 | |
| f | 12 V | 5.5 | 6.0 | 7.0 | 6.0 ± 0.5 |
| | 6 V | | | 7.0 | |
| Lateral deviation ^{1/} | 6, 12 V | | | ^{3/} | 0.3 max. |
| | 24 V | | | 1.5 | |
| β | | 75° | 90° | 105° | 90° ± 5° |
| Cap BA15s in accordance with IEC Publication 60061 (sheet 7004-11A-9) ^{2/} | | | | | |
| Electrical and photometric characteristics | | | | | |
| Rated values | Volts | 6 | 12 | 24 | 12 |
| | Watts | 21 | | | 21 |
| Test voltage | Volts | 6.75 | 13.5 | 28.0 | 13.5 |
| Objective values | Watts | 27.6 max. | 26.5 max. | 29.7 max. | 26.5 max. |
| | Luminous flux | 460 ± 15 % | | | |
| Reference luminous flux: 460 lm at approximately 13.5 V | | | | | |

- ^{1/} Maximum lateral deviation of filament centre from two mutually perpendicular planes both containing the reference axis and one containing the axis of the pins.
- ^{2/} Filament light sources with cap BA15d may be used for special purposes; they have the same dimensions.
- ^{3/} To be checked by means of a "Box system"; sheet P21W/2.
- ^{4/} In this view the filament of the 24 V type may be straight or V-shaped. If it is straight, the screen projection requirements, sheet P21W/2, apply. If it is V-shaped, the filament ends shall be at the same distance within ±3 mm from the reference plane.

Screen projection requirements

This test is used to determine, by checking whether the filament is correctly positioned relative to the reference axis and reference plane and has an axis perpendicular, within $\pm 15^\circ$, to the plane through the centre line of the pins (P21W) or of the reference pin (PY21W and PR21W) and the reference axis, whether a filament light source complies with the requirements.

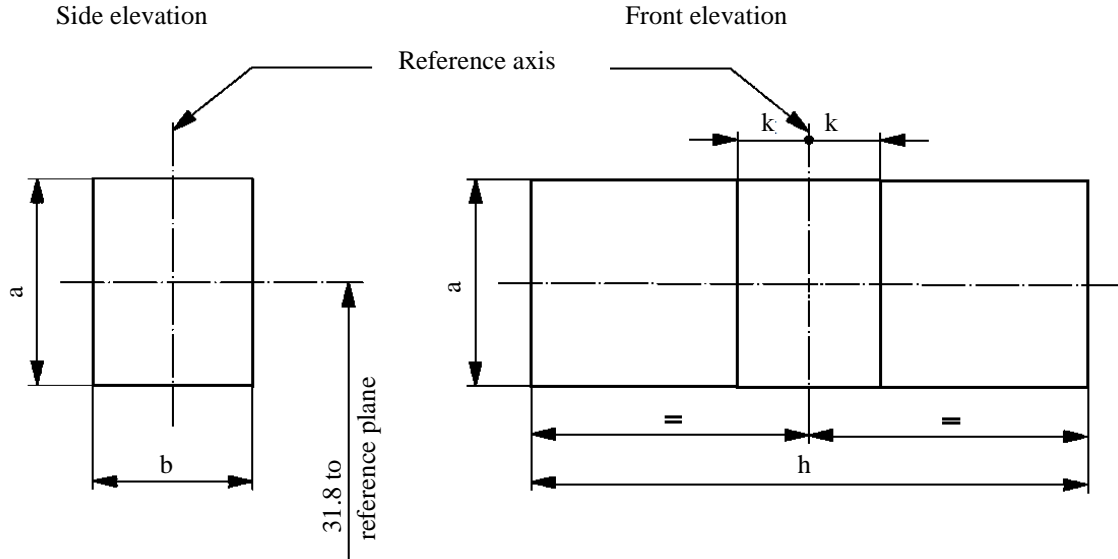

| Reference | a | b | h | k |
|-----------|-----|-----|-----|-----|
| Dimension | 3.5 | 3.0 | 9.0 | 1.0 |

Test procedures and requirements

1. The filament light source is placed in a holder capable of being rotated about its axis and having either a calibrated scale or fixed stops corresponding to the angular displacement tolerance limits. The holder is then so rotated that an end view of the filament is seen on the screen on to which the image of the filament is projected. The end view of the filament shall be obtained within the angular displacements tolerance limits.
2. Side elevation
The filament light source placed with the cap down, the reference axis vertical and the filament seen end-on, the projection of the filament shall lie entirely within a rectangle of height "a" and width "b", having its centre at the theoretical position of the centre of the filament.
3. Front elevation
The filament light source placed with the cap down and the reference axis vertical, the filament light source being viewed in a direction at right angles to the filament axis:
 - 3.1. The projection of the filament shall lie entirely within a rectangle of height "a" and width "h", having its centre at the theoretical position of the centre of the filament.
 - 3.2. The centre of the filament shall not be offset by more than distance "k" from the reference axis.

Category P21/4W

Sheet P21/4W/1

The drawings are intended only to illustrate the essential dimensions (in mm) of the filament light source.

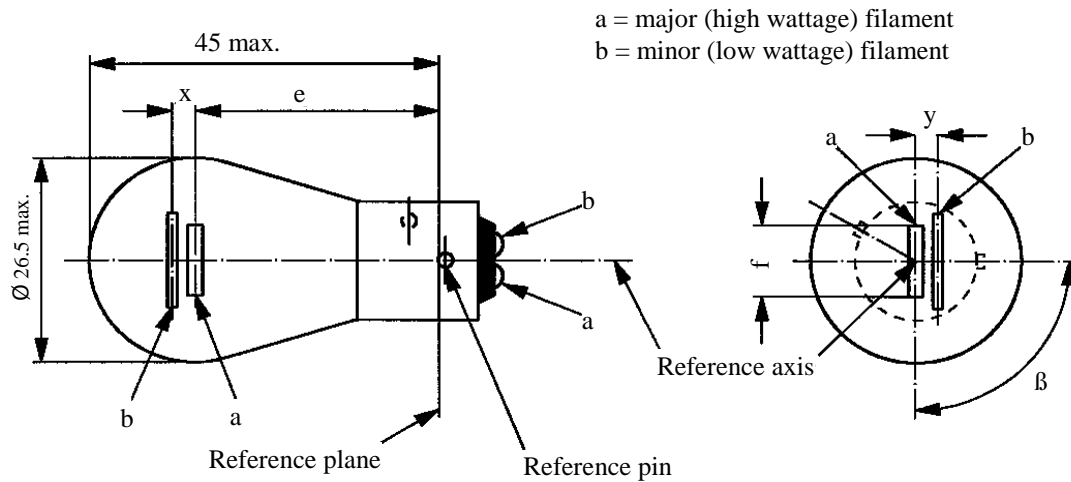

| Dimensions in mm | Filament light sources of normal production | | | Standard filament light source | | |
|--|---|--------------------|--------------------|--------------------------------|----------|---------------|
| | Min. | Nom. | Max. | | | |
| e | | 31.8 ^{1/} | | 31.8 ± 0.3 | | |
| f | | | 7.0 | 7.0 + 0 / - 2 | | |
| Lateral deviation | | | ^{1/} | 0.3 max. ^{2/} | | |
| x,y | ^{1/} | | | 2.8 ± 0.5 | | |
| β | 75° ^{1/} | 90° ^{1/} | 105° ^{1/} | 90° ± 5° | | |
| Cap BAZ15d in accordance with IEC Publication 60061 (sheet 7004-11C-3) | | | | | | |
| Electrical and photometric characteristics | | | | | | |
| Rated values | Volts | 12 | | 24 | 12 | |
| | Watts | 21 | 4 | 21 | 4 | 21/4 |
| Test voltage | Volts | 13.5 | | 28.0 | 13.5 | |
| Objective values | Watts | 26.5 max. | 5.5 max. | 29.7 max. | 8.8 max. | 26.5/5.5 max. |
| | Luminous flux | 440 | 15 | 440 | 20 | |
| | ± % | 15 | 20 | 15 | 20 | |
| Reference luminous flux: 440 lm and 15 lm at approximately 13.5 V | | | | | | |

^{1/} These dimensions shall be checked by means of a "Box system"^{3/} based on the dimensions and tolerances shown above. "x" and "y" refer to the major (high wattage) filament, not to the reference axis. Means of increasing the positioning accuracy of the filament and of the cap-holder assembly are under consideration.

^{2/} Maximum lateral deviation of the major filament centre from two mutually perpendicular planes both containing the reference axis and one containing the axis of the reference pin.

^{3/} The "Box system" is the same as for filament light source P21/5W; see sheets P21/5W/2 to 3.

The drawings are intended only to illustrate the essential dimensions (in mm) of the filament light source.

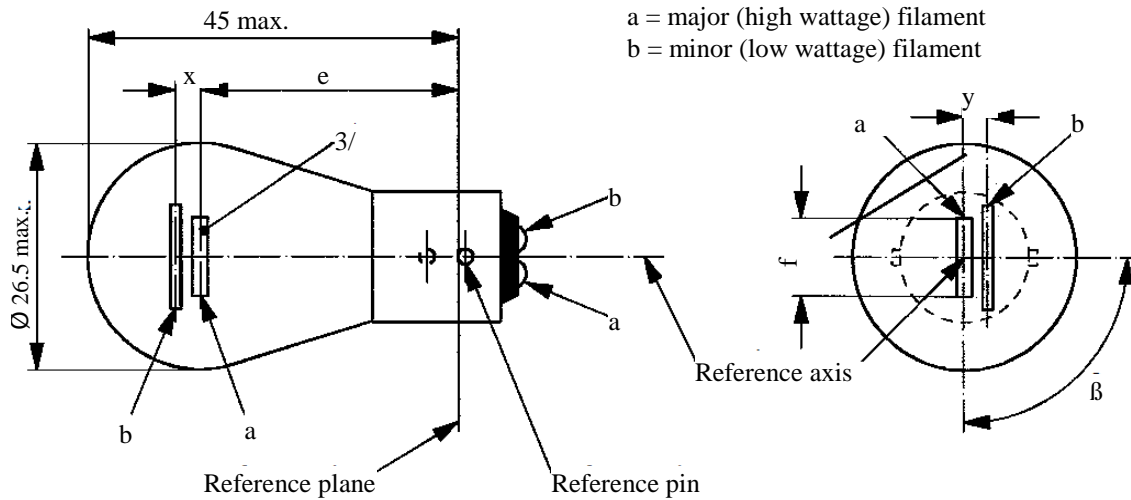

| Dimensions in mm | | Filament light sources of normal production | | | Standard filament light source | | | |
|--|--------------------|---|--------------------|---------------|--------------------------------|-----------|-----------|-------------------|
| | | Min. | Nom. | Max. | | | | |
| e | 6, 12 V | | 31.8 ^{1/} | | 31.8 ± 0.3 | | | |
| | 24 V | 30.8 | 31.8 | 32.8 | | | | |
| f | 6, 12 V | | | 7.0 | 7.0 + 0 / - 2 | | | |
| Lateral deviation ^{2/} | 6, 12 V | | | ^{1/} | 0.3 max. | | | |
| | 24 V | | | 1.5 | | | | |
| x, y | 6, 12 V | | ^{1/} | | 2.8 ± 0.3 | | | |
| x | 24 V ^{3/} | -1.0 | 0 | 1.0 | | | | |
| y | 24 V ^{3/} | 1.8 | 2.8 | 3.8 | | | | |
| β | | 75° | 90° | 105° | 90° ± 5° | | | |
| Cap BAY15d in accordance with IEC Publication 60061 (sheet 7004-11B-7) | | | | | | | | |
| Electrical and photometric characteristics | | | | | | | | |
| Rated values | Volts | 6 | | 12 | | 24 | | 12 |
| | Watts | 21 | 5 | 21 | 5 | 21 | 5 | 21/5 |
| Test voltage | Volts | 6.75 | | 13.5 | | 28.0 | | 13.5 |
| Objective values | Watts | 27.6 max. | 6.6 max. | 26.5 max. | 6.6 max. | 29.7 max. | 11.0 max. | 26.5 and 6.6 max. |
| | Luminous flux | 440 | 35 | 440 | 35 | 440 | 40 | |
| | ± % | 15 | 20 | 15 | 20 | 15 | 20 | |
| Reference luminous flux: 440 and 35 lm at approximately 13.5 V | | | | | | | | |

For the notes see sheet P21/5W/2

- ^{1/} These dimensions shall be checked by means of a "Box system". See sheets P21/5W/2 and P21/5W/3. "x" and "y" refer to the major (high wattage) filament, not to the reference axis.
- ^{2/} Maximum lateral deviation of the major (high wattage) filament centre from two mutually perpendicular planes both containing the reference axis and one containing the axis of the reference pin.
- ^{3/} In this view the filaments of the 24 V type may be straight or V-shaped. If the filaments are straight, the screen projection requirements apply. If they are V-shaped, the ends of each filament shall be at the same distance within ± 3 mm from the reference plane.

Screen projection requirements

This test is used to determine, by checking whether:

- (a) The major (high wattage) filament is correctly positioned relative to the reference axis and reference plane and has an axis perpendicular, within $\pm 15^\circ$, to the plane through the centres of the pins and the reference axis; and whether
- (b) The minor (low wattage) filament is correctly positioned relative to the major (high wattage) filament, whether a filament light source complies with the requirements.

Test procedure and requirements

1. The filament light source is placed in a holder capable of being rotated about its axis and having either a calibrated scale or fixed stops corresponding to the angular displacement tolerance limits. (i.e. 15°). The holder is then so rotated that an end view of the major filament is seen on the screen on which the image of the filament is projected. The end view of that filament shall be obtained within the angular displacement tolerance limits.
2. Side elevation

The filament light source placed with the cap down, the reference axis vertical, the reference pin to the right and the major filament seen end-on:

 - 2.1. The projection of the major filament shall lie entirely within a rectangle of height "a" and width "b", having its centre at the theoretical position of the centre of the filament;
 - 2.2. The projection of the minor filament shall lie entirely:
 - 2.2.1. Within a rectangle of width "c" and height "d" having its centre at a distance "v" to the right of and at a distance "u" above the theoretical position of the centre of the major filament;
 - 2.2.2. Above a straight line tangential to the upper edge of the projection of the major filament and rising from left to right at an angle of 25° .
 - 2.2.3. To the right of the projection of the major filament.
3. Front elevation

The filament light source being placed with the cap down and the reference axis vertical, the filament light source being viewed in a direction at right angles to axis of the major filament:

 - 3.1. The projection of the major filament shall lie entirely within a rectangle of height "a" and width "h", centred on the theoretical position of the centre of the filament;
 - 3.2. The centre of the major filament shall not be offset by more than distance "k" from the reference axis.
 - 3.3. The centre of the minor filament axis shall not be offset from the reference axis by more than ± 2 mm (± 0.4 mm for standard filament light sources).

Dimensions in mm

Side elevation

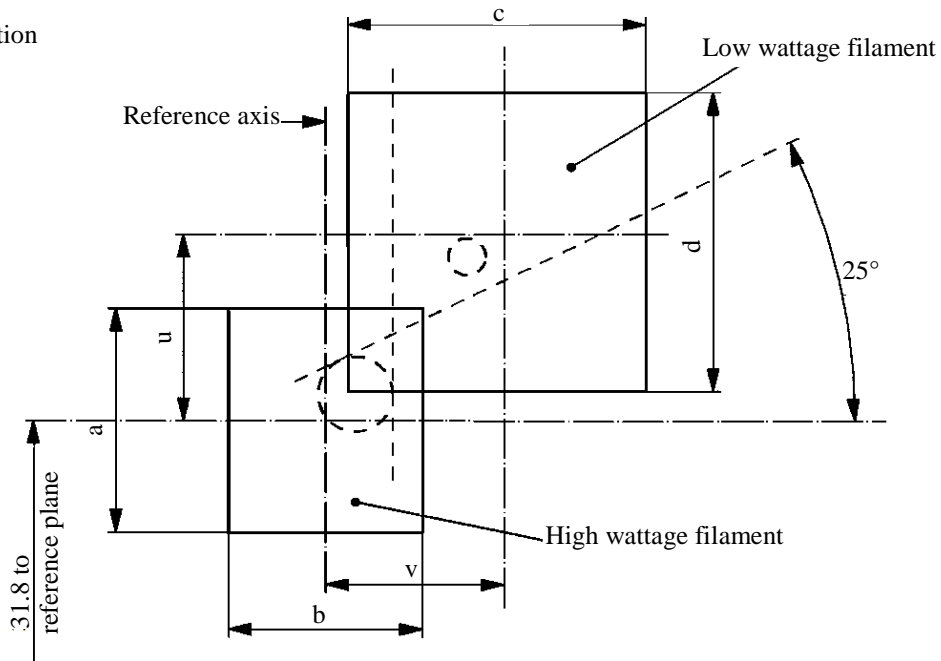

| Reference | <i>a</i> | <i>b</i> | <i>c</i> | <i>d</i> | <i>u</i> | <i>v</i> |
|------------|----------|----------|----------|----------|----------|----------|
| Dimensions | 3.5 | 3.0 | 4.8 | | 2.8 | |

Front elevation

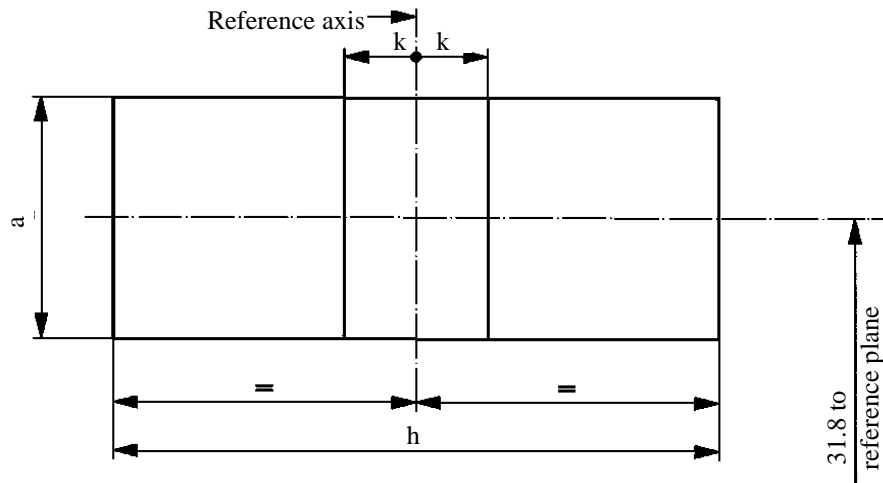

| Reference | <i>a</i> | <i>h</i> | <i>k</i> |
|------------|----------|----------|----------|
| Dimensions | 3.5 | 9.0 | 1.0 |

Categories P24W, PX24W, PY24W, PR24W, PS24W, PSX24W, PSY24W, PSR24W, PW24W,
PWY24W and PWR24W

The drawings are intended only to illustrate the essential dimensions (in mm) of the filament light source.

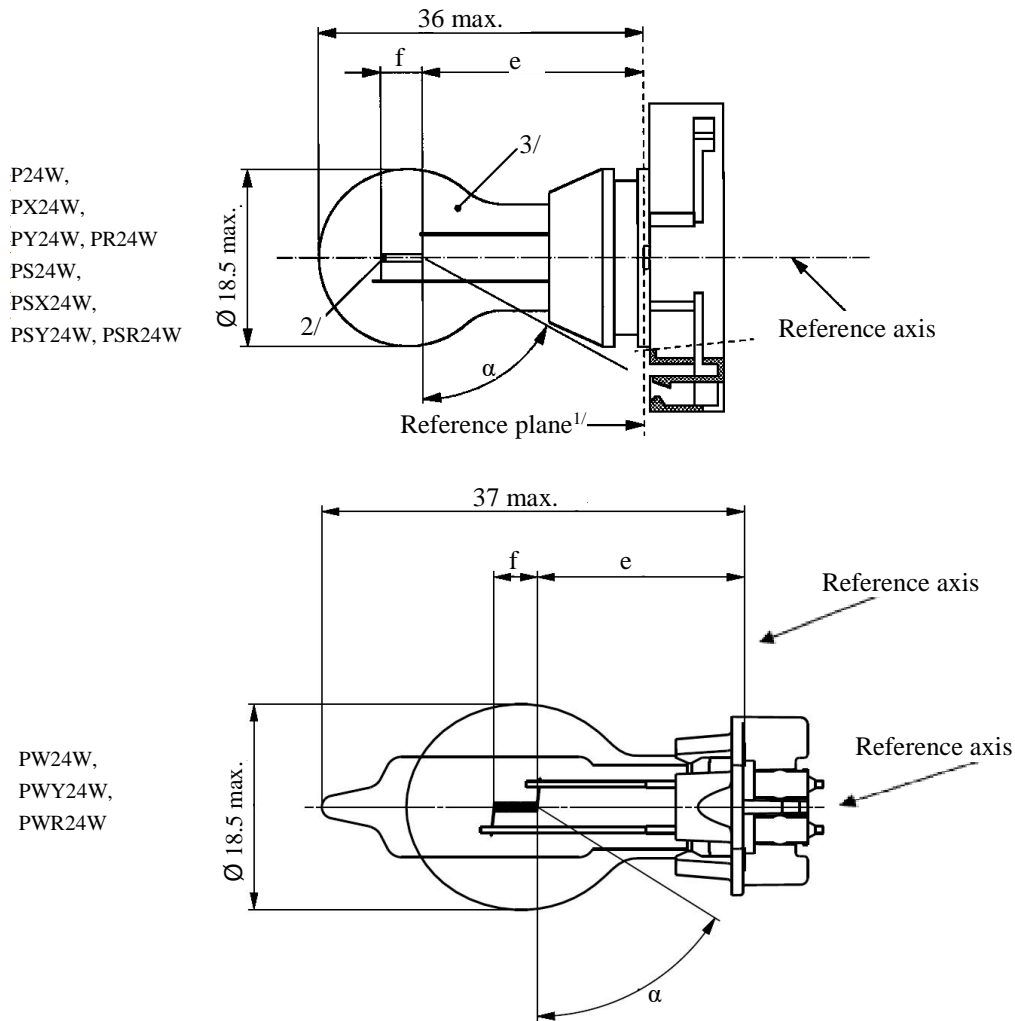

^{1/} The reference plane is defined by the meeting points of the cap-holder fit.

^{2/} No actual filament diameter restrictions apply but the objective is $d \text{ max.} = 1.1 \text{ mm}$.

^{3/} The light emitted from normal production filament light sources shall be white for categories P24W, PX24W, PS24W, PSX24W and PW24W; amber for categories PY24W, PSY24W and PWY24W; red for categories PR24W, PSR24W and PWR24W (see also footnote 8/).

Categories P24W, PX24W, PY24W, PR24W, PS24W, PSX24W, PSY24W, PSR24W, PW24W, PWY24W and PWR24W

| Dimensions in mm ^{4/} | | Filament light sources of normal production | | | Standard filament light source ^{8/} |
|--|---|---|---------------|---|--|
| | | Min. | Nom. | Max. | |
| e ^{5/, 6/} | P24W, PY24W, PR24W, PS24W, PSY24W, PSR24W, PX24W, PSX24W | | 24.0 | | 24.0 |
| | PW24W, PWY24W, PWR24W | | 18.1 | | 18.1 |
| f ^{5/, 6/} | P24W, PY24W, PR24W, PS24W, PSY24W, PSR24W, PW24W, PWY24W, PWR24W | | 4.0 | | 4.0 |
| | PX24W, PSX24W | | 4.2 | | 4.2 |
| α ^{7/} | | 58.0° | | | 58.0° min. |
| P24W | Cap PGU20-3 | in accordance with IEC Publication 60061 (sheet 7004-127-2) | | | |
| PX24W | Cap PGU20-7 | | | | |
| PY24W | Cap PGU20-4 | | | | |
| PR24W | Cap PGU20-6 | | | | |
| PS24W | Cap PG20-3 | | | | |
| PSX24W | Cap PG20-7 | | | | |
| PSY24W | Cap PG20-4 | | | | |
| PSR24W | Cap PG20-6 | | | | |
| PW24W | Cap WP3.3x14.5-3 | in accordance with IEC Publication 60061 (sheet 7004-164-2) | | | |
| PWY24W | Cap WP3.3x14.5-4 | | | | |
| PWR24W | Cap WP3.3x14.5-6 | | | | |
| Electrical and photometric characteristics | | | | | |
| Rated values | Volts | | 12 | 12 | |
| | Watts | | 24 | 24 | |
| Test voltage | Volts | | 13.5 | 13.5 | |
| Objective values | Watts | | 25 max. | 25 max. | |
| | Luminous flux | P24W PS24W PW24W | 500 +10/-20 % | | |
| | | PX24W PSX24W | 500 +10/-15 % | | |
| | | PY24W PSY24W PWY24W | 300 +15/-25 % | | |
| | | PR24W PSR24W PWR24W | 115 +15/-25 % | | |
| Reference luminous flux at approximately | | | 12 V | White: 345 lm | |
| | | | 13.2 V | White: 465 lm | |
| | | | 13.5 V | White: 500 lm Amber: 300 lm Red: 115 lm | |

^{4/} For categories PS24W, PSX24W, PSY24W and PSR24W, dimensions may be checked with O-ring removed to assure the correct mounting during testing.

^{5/} The filament position is checked by means of a "Box system"; sheet P24W/3.

^{6/} The ends of the filament are defined as the points where, when the viewing direction is perpendicular to the plane through the filament lead-in wires as showed in the drawing on sheet P24W/1, the projection of the outside of the end turns crosses the filament axis.

^{7/} No part of the cap beyond the reference plane shall interfere with angle α . The bulb shall be optically distortion free within the angle $2\alpha + 180^\circ$.

^{8/} The light emitted from standard filament light sources shall be white for categories P24W, PX24W, PS24W, PSX24W and PW24W; white or amber for categories PY24W, PSY24W and PWY24W; white or red for categories PR24W, PSR24W and PWR24W.

Screen projection requirements

This test is used to determine, by checking whether the filament is correctly positioned relative to the reference axis and reference plane, whether a filament light source complies with the requirements.

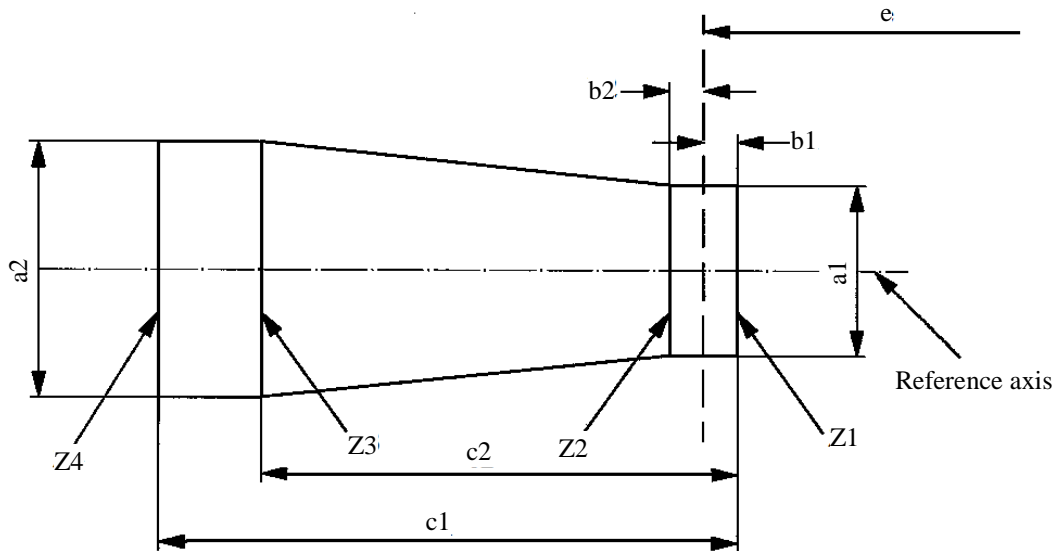

| <i>P24W, PY24W, PR24W, PS24W, PSY24W, PSR24W</i> | <i>a1</i> | <i>a2</i> | <i>b1, b2</i> | <i>c1</i> | <i>c2</i> |
|--|-----------|-----------|---------------|-----------|-----------|
| Filament light sources of normal production | 2.9 | 3.9 | 0.5 | 5.2 | 3.8 |
| Standard filament light sources | 1.5 | 1.7 | 0.25 | 4.7 | 3.8 |

| <i>PW24W, PWY24W, PWR24W</i> | <i>a1</i> | <i>a2</i> | <i>b1, b2</i> | <i>c1</i> | <i>c2</i> |
|---|-----------|-----------|---------------|-----------|-----------|
| Filament light sources of normal production | 2.5 | 2.5 | 0.4 | 5.0 | 3.8 |
| Standard filament light sources | 1.5 | 1.7 | 0.25 | 4.7 | 3.8 |

| <i>PX24W, PSX24W</i> | <i>a1</i> | <i>a2</i> | <i>b1, b2</i> | <i>c1</i> | <i>c2</i> |
|---|-----------|-----------|---------------|-----------|-----------|
| Filament light sources of normal production | 1.9 | 1.9 | 0.35 | 5.0 | 4.0 |
| Standard filament light sources | 1.5 | 1.5 | 0.25 | 4.7 | 4.0 |

The filament position is checked in two mutually perpendicular planes, one of them being the plane through the lead-in wires.

The ends of the filament as defined on sheet P24W/2, footnote 6/, shall lie between Z1 and Z2 and between the lines Z3 and Z4.

The filament shall lie entirely within the limits shown.

The drawings are intended only to illustrate the essential dimensions (in mm) of the filament light source.

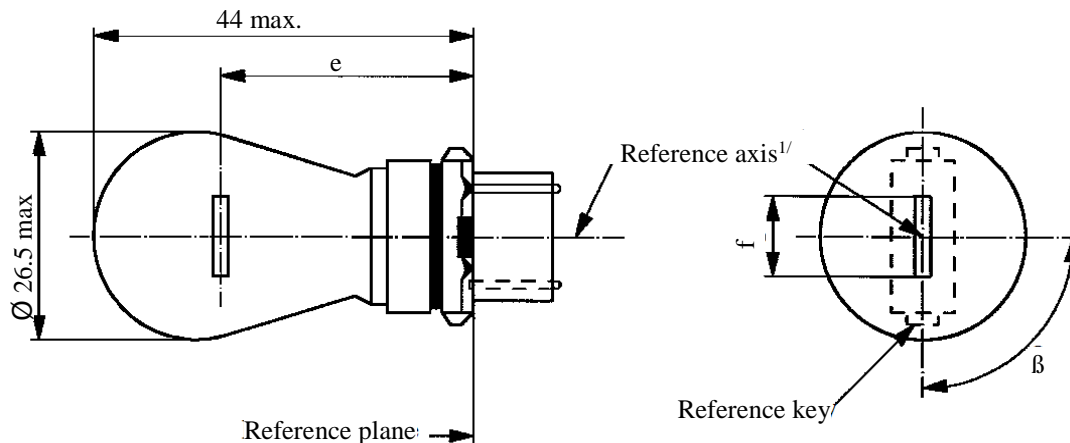

| Dimensions in mm | Filament light sources of normal production | | | Standard filament light source |
|--|---|--------------------|--------------------|--------------------------------|
| | Min. | Nom. | Max. | |
| e | | 27.9 ^{3/} | | 27.9 ± 0.3 |
| f | | | 9.9 | 9.9 + 0 / - 2 |
| Lateral deviation ^{2/} | | | ^{3/} | 0.0 ± 0.4 |
| β | 75° ^{3/} | 90° | 105° ^{3/} | 90° ± 5° |
| Cap W2.5x16d in accordance with IEC Publication 60061 (sheet 7004-104-1) | | | | |
| Electrical and photometric characteristics | | | | |
| Rated values | Volts | 12 | | 12 |
| | Watts | 27 | | 27 |
| Test voltage | Volts | 13.5 | | 13.5 |
| Objective values | Watts | 32.1 max. | | 32.1 max. |
| | Luminous flux | 475 ± 15 % | | |
| Reference luminous flux: 475 lm at approximately 13.5 V | | | | |

^{1/} The reference axis is defined with respect to the reference keys and is perpendicular to the reference plane.

^{2/} Maximum lateral deviation of filament centre from two mutually perpendicular planes both containing the reference axis and one containing the axis through the reference keys.

^{3/} To be checked by means of a "Box system", sheet P27W/2.

Screen projection requirements

This test is used to determine, by checking whether the filament is correctly positioned relative to the reference axis and reference plane and has an axis perpendicular, within $\pm 15^\circ$, to the plane through the centres of the keys and the reference axis, whether a filament light source complies with the requirements.

Side elevation

Front elevation

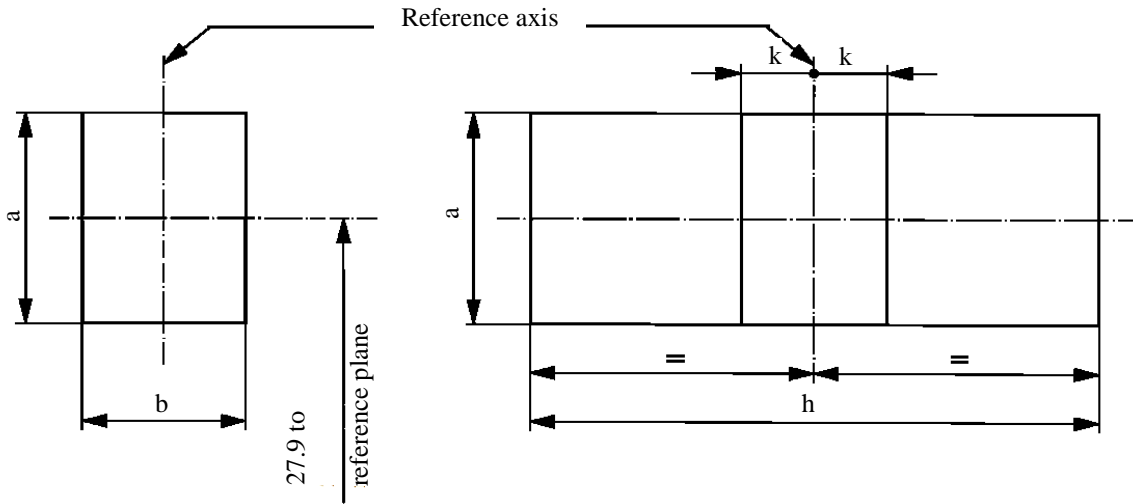

| Reference | a | b | h | k |
|-----------|-----|-----|------|-----|
| Dimension | 3.5 | 3.0 | 11.9 | 1.0 |

Test procedures and requirements.

1. The filament light source is placed in a holder capable of being rotated about its axis and having either a calibrated scale or fixed stops corresponding to the angular displacement tolerance limits. The holder is then so rotated that an end view of the filament is seen on the screen on to which the image of the filament is projected. The end view of the filament shall be obtained within the angular displacements tolerance limits.
2. Side elevation
The filament light source placed with the cap down, the reference axis vertical and the filament seen end-on, the projection of the filament shall lie entirely within a rectangle of height "a" and width "b", having its centre at the theoretical position of the centre of the filament.
3. Front elevation
The filament light source placed with the cap down and the reference axis vertical, the filament light source being viewed in a direction at right angles to the filament axis:
 - 3.1. The projection of the filament shall lie entirely within a rectangle of height "a" and width "h", having its centre at the theoretical position of the centre of the filament.
 - 3.2. The centre of the filament shall not be offset by more than distance "k" from the reference axis.

The drawings are intended only to illustrate the essential dimensions (in mm) of the filament light source.

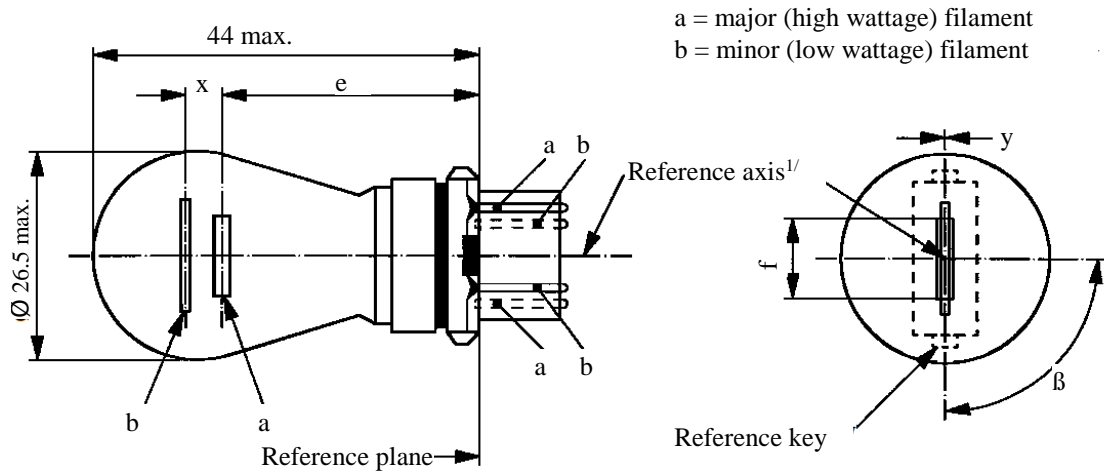

| Dimensions in mm | Filament light sources of normal production | | | Standard filament light source | |
|--|---|--------------------|--------------------|--------------------------------|----------|
| | Min. | Nom. | Max. | | |
| e | | 27.9 ^{3/} | | 27.9 ± 0.3 | |
| f | | | 9.9 | 9.9 + 0 / -2 | |
| Lateral deviation ^{2/} | | | ^{3/} | 0.0 ± 0.4 | |
| x ^{4/} | | 5.1 ^{3/} | | 5.1 ± 0.5 | |
| y ^{4/} | | 0.0 ^{3/} | | 0.0 ± 0.5 | |
| β | 75° ^{3/} | 90° | 105° ^{3/} | 90° ± 5° | |
| Cap W2.5x16q in accordance with IEC Publication 60061 (sheet 7004-104-1) | | | | | |
| Electrical and photometric characteristics | | | | | |
| Rated values | Volts | 12 | | 12 | |
| | Watts | 27 | 7 | 27 | 7 |
| Test voltage | Volts | 13.5 | | 13.5 | |
| Objective values | Watts | 32.1 max. | 8.5 max. | 32.1 max. | 8.5 max. |
| | Luminous flux | 475 ± 15 % | 36 ± 15 % | | |
| Reference luminous flux: 475 and 36 lm at approximately 13.5 V | | | | | |

^{1/} The reference axis is defined with respect to the reference keys and is perpendicular to the reference plane.

^{2/} Maximum lateral deviation of the major (high wattage) filament centre from two mutually perpendicular planes both containing the reference axis and one containing the axis through the reference keys.

^{3/} To be checked by means of a "Box system", sheets P27/7W/2 and 3.

^{4/} "x" and "y" denote the offset of the axis of the minor (low wattage) filament with respect to the axis of the major (high wattage) filament.

Screen projection requirements

This test is used to determine, by checking whether:

- (a) The major (high wattage) filament is correctly positioned relative to the reference axis and reference plane and has an axis perpendicular, within $\pm 15^\circ$, to the plane through the centres of the keys and the reference axis; and whether:
- (b) The minor (low wattage) filament is correctly positioned relative to the major (high wattage) filament, whether a filament light source complies with the requirements.

Test procedure and requirements.

1. The filament light source is placed in a holder capable of being rotated about its axis and having either a calibrated scale or fixed stops corresponding to the angular displacement tolerance limits. The holder is then so rotated that an end view of the major filament is seen on the screen on which the image of the filament is projected. The end view of that filament shall be obtained within the angular displacement tolerance limits.
2. Side elevation
The filament light source placed with the cap down, the reference axis vertical, the reference key to the right and the major filament seen end-on:
 - 2.1. The projection of the major filament shall lie entirely within a rectangle of height "a" and width "b", having its centre at the theoretical position of the centre of the filament;
 - 2.2. The projection of the minor filament shall lie entirely within a rectangle of width "c" and height "d" having its centre at a distance "u" above the theoretical position of the centre of the major filament.
3. Front elevation
The filament light source being placed with the cap down and the reference axis vertical, the filament light source being viewed in a direction at right angles to axis of the major filament:
 - 3.1. The projection of the major filament shall lie entirely within a rectangle of height "a" and width "h", centred on the theoretical position of the centre of the filament;
 - 3.2. The centre of the major filament shall not be offset by more than distance "k" from the reference axis;
 - 3.3. The centre of the minor filament axis shall not be offset from the reference axis by more than ± 2 mm (± 0.4 mm for standard filament light sources).

Side elevation

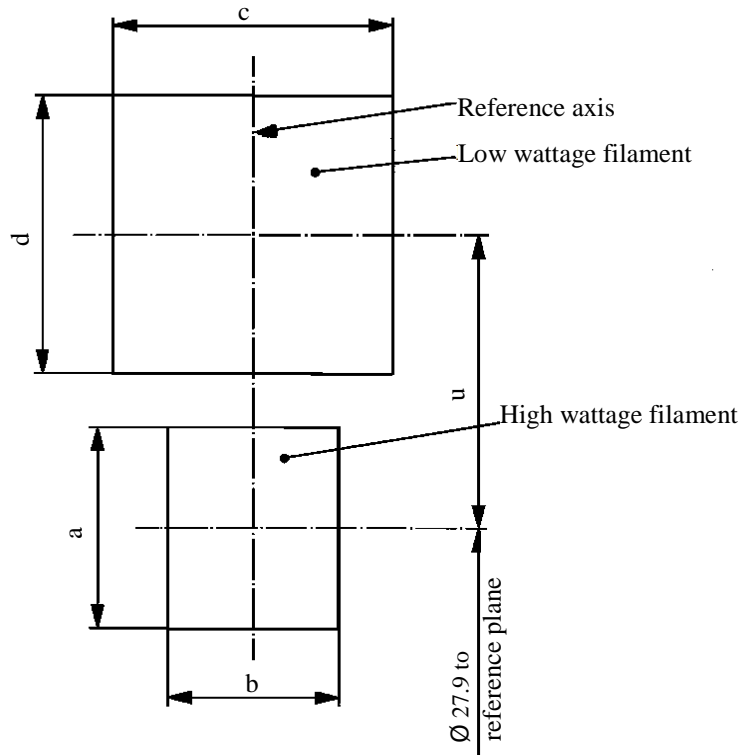

| Reference | a | b | c | d | u |
|-----------|-----|-----|-----|-----|-----|
| Dimension | 3.5 | 3.0 | 4.8 | | 5.1 |

Front elevation

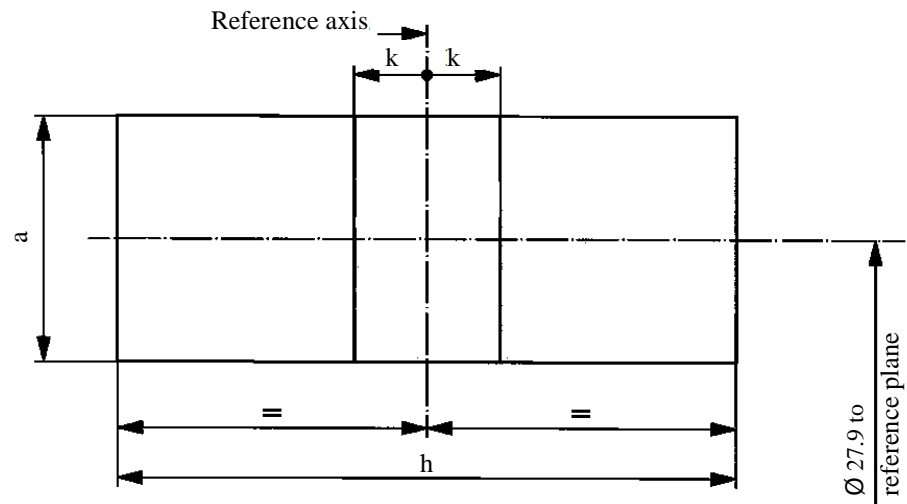

| Reference | a | h | k |
|-----------|-----|------|-----|
| Dimension | 3.5 | 11.9 | 1.0 |

Categories PC16W, PCY16W, PCR16W, PW16W, PWY16W and PWR16W

The drawings are intended only to illustrate the essential dimensions (in mm) of the filament light source.

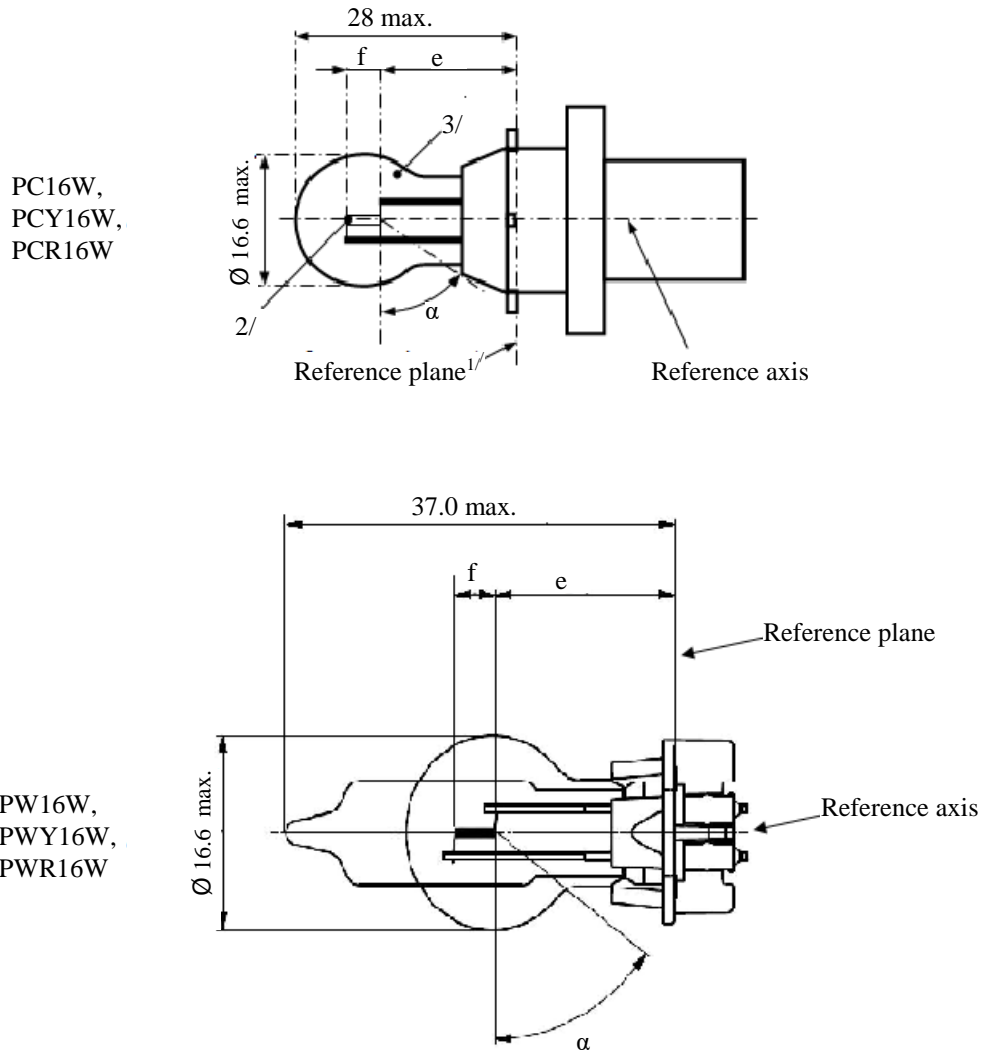

^{1/} The reference plane is defined by the meeting points of the cap-holder fit.

^{2/} No actual filament diameter restrictions apply but the objective is $d_{max.} = 1.1$ mm.

^{3/} The light emitted from normal production filament light sources shall be white for category PC16W and PW16W; amber for category PCY16W and PWY16W; red for category PCR16W and PWR16W. (see also footnote 7/).

Categories PC16W, PCY16W, PCR16W, PW16W, PWY16W and PWR16W

| Dimensions in mm | | Filament light sources of normal production | | | Standard filament light source ^{7/} | |
|--|---------------------------|---|------------|--|--|--|
| | | Min. | Nom. | Max. | | |
| e ^{4/, 5/} | PC16W PCY16W PCR16W | | 18.5 | | 18.5 | |
| | PW16W PWY16W PWR16W | | 17.1 | | 17.1 | |
| f ^{4/, 5/} | | | 4.0 | | 4.0 ± 0.2 | |
| α ^{6/} | | 54° | | | 54° min. | |
| PC16W | Cap PU20d-1 | in accordance with IEC Publication 60061 (sheet 7004-158-1) | | | | |
| PCY16W | Cap PU20d-2 | | | | | |
| PCR16W | Cap PU20d-7 | | | | | |
| PW16W | Cap WP3.3x14.5-8 | in accordance with IEC Publication 60061 (sheet 7004-164-2) | | | | |
| PWY16W | Cap WP3.3x14.5-9 | | | | | |
| PWR16W | Cap WP3.3x14.5-10 | | | | | |
| Electrical and photometric characteristics | | | | | | |
| Rated values | Volts | 12 | | | 12 | |
| | Watts | 16 | | | 16 | |
| Test voltage | Volts | 13.5 | | | 13.5 | |
| Objective values | Watts | 17 max. | | | 17 max. | |
| | Luminous flux | PC16W PW16W | 300 ± 15 % | | | |
| | | PCY16W PWY16W | 180 ± 20 % | | | |
| | | PCR16W PWR16W | 70 ± 20 % | | | |
| Reference luminous flux at approximately | | | 13.5 V | White: 300 lm Amber: 180 lm Red: 70 lm | | |

^{4/} The filament position is checked by means of a "Box system"; sheet PC16W/3.

^{5/} The ends of the filament are defined as the points where, when the viewing direction is perpendicular to the plane through the filament lead-in wires as showed in the drawing on sheet PC16W/1, the projection of the outside of the end turns crosses the filament axis.

^{6/} No part of the cap beyond the reference plane shall interfere with angle α. The bulb shall be optically distortion free within the angle 2α + 180°.

^{7/} The light emitted from standard filament light sources shall be white for category PC16W and PW16W; white or amber for category PCY16W and PWY16W; white or red for category PCR16W and PWR16W.

Categories PC16W, PCY16W, PCR16W, PW16W, PWY16W and PWR16W

Screen projection requirements

This test is used to determine, by checking whether the filament is correctly positioned relative to the reference axis and reference plane, whether a filament light source complies with the requirements.

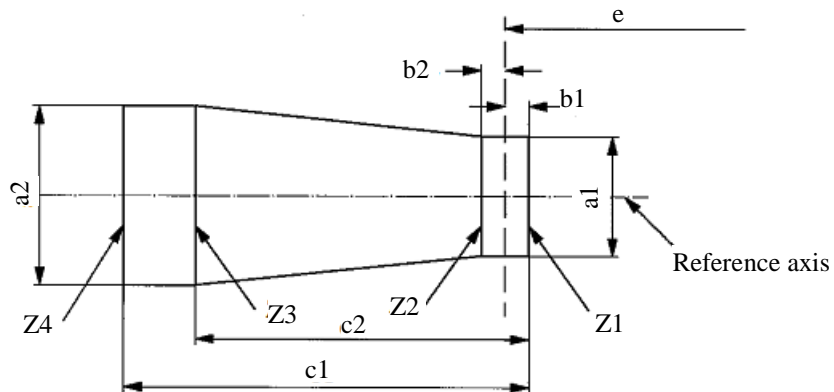

| <i>PC16W, PCY16W, PCR16W</i> | <i>a1</i> | <i>a2</i> | <i>b1, b2</i> | <i>c1</i> | <i>c2</i> |
|---|-----------|-----------|---------------|-----------|-----------|
| Filament light sources of normal production | 2.9 | 3.9 | 0.5 | 5.2 | 3.8 |
| Standard filament light sources | 1.5 | 1.7 | 0.25 | 4.7 | 3.8 |

| <i>PW16W, PWY16W and PWR16W</i> | <i>a1</i> | <i>a2</i> | <i>b1, b2</i> | <i>c1</i> | <i>c2</i> |
|---|-----------|-----------|---------------|-----------|-----------|
| Filament light sources of normal production | 2.5 | 2.5 | 0.4 | 5.2 | 3.8 |
| Standard filament light sources | 1.5 | 1.7 | 0.25 | 4.7 | 3.8 |

The filament position is checked in two mutually perpendicular planes, one of them being the plane through the lead-in wires.

The ends of the filament as defined on sheet PC16W/2, footnote 5/, shall lie between Z1 and Z2 and between the lines Z3 and Z4.

The filament shall lie entirely within the limits shown.

The drawings are intended only to illustrate the essential dimensions (in mm) of the filament light source.

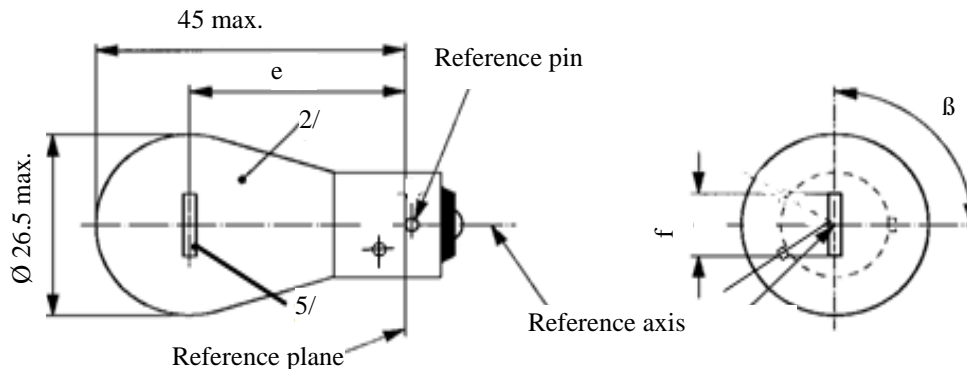

| Dimensions in mm | | Filament light sources of normal production | | | Standard filament light source ^{4/} |
|--|----------------|---|--------------------|---------------|--|
| | | Min. | Nom. | Max. | |
| e | 12 V | | 31.8 ^{3/} | | 31.8 ± 0.3 |
| | 24 V | 30.8 | 31.8 | 32.8 | |
| f | 12 V | 5.5 | 6.0 | 7.0 | 6.0 ± 0.5 |
| Lateral deviation ^{1/} | 12 V | | | ^{3/} | 0.3 max |
| | 24 V | | | 1.5 | |
| β | | 75° | 90° | 105° | 90° ± 5° |
| Cap BAW15s in accordance with IEC Publication 60061 (sheet 7004-11E-1) | | | | | |
| Electrical and photometric characteristics | | | | | |
| Rated values: | Volts | 12 | 24 | 12 | |
| | Watts | 21 | | | 21 |
| Test voltage: | Volts | 13.5 | 28.0 | | |
| Objective values: | Watts | 26.5 max. | 29.7 max. | 26.5 max. | |
| | Luminous flux: | 110 ± 20 % | | | |
| Reference luminous flux at approximately 13.5 V: | | | | | White: 460 lm Red: 110 lm |

^{1/} Maximum lateral deviation of filament centre from two mutually perpendicular planes both containing the reference axis and one containing the axis of the reference pin.

^{2/} The light emitted from normal production filament light sources shall be red (see also footnote 4/).

^{3/} To be checked by means of a "Box system", sheet P21W/2.

^{4/} The light emitted from standard filament light sources shall be white or red.

^{5/} In this view the filament of the 24 V type may be straight or V-shaped. If it is straight, the screen projection requirements, sheet P21W/2, apply. If it is V-shaped, the filament ends shall be at the same distance within ±3 mm from the reference plane.

Category PR21/4W

Sheet PR21/4W/1

The drawings are intended only to illustrate the essential dimensions (in mm) of the filament light source.

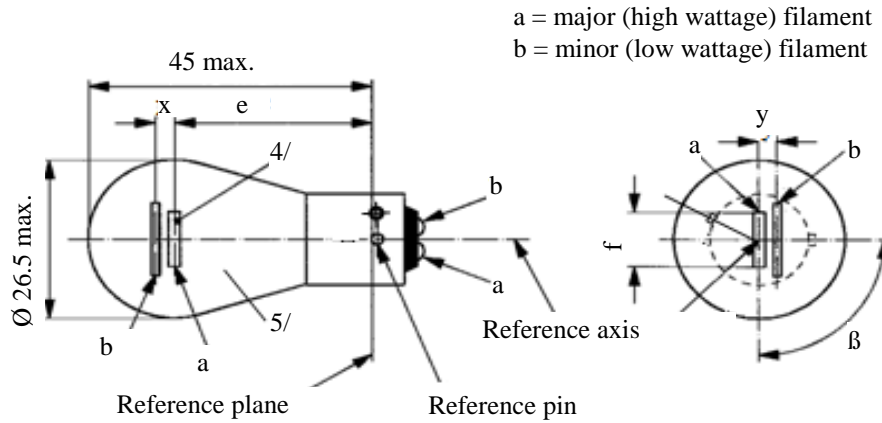

| Dimensions in mm | Filament light sources of normal production ^{5/} | | | | Standard filament light source ^{6/} | |
|---|---|--------------------|--------------------|------------------|--|---------------|
| | Min. | Nom. | Max. | | | |
| e | | 31.8 ^{1/} | | | 31.8 ± 0.3 | |
| f | | | 7.0 | | 7.0 + 0 / -2 | |
| Lateral deviation | | | ^{1/} | | 0.3 max. ^{2/} | |
| x,y | ^{1/} | | | | 2.8 ± 0.5 | |
| β | 75° ^{1/} | 90° ^{1/} | 105° ^{1/} | | 90° ± 5° | |
| Cap BAU15d in accordance with IEC Publication 60061 (sheet 7004-19-2) | | | | | | |
| Electrical and photometric characteristics | | | | | | |
| Rated values | Volts | 12 | | 24 ^{4/} | | 12 |
| | Watts | 21 | 4 | 21 | 4 | 21/4 |
| Test voltage | Volts | 13.5 | | 28.0 | | 13.5 |
| Objective values | Watts | 26.5 max. | 5.5 max. | 29.7 max. | 8.8 max. | 26.5/5.5 max. |
| | Luminous flux | 105 | 4 | 105 | 5 | |
| | ± % | 20 | 25 | 20 | 25 | |
| Reference luminous flux at approximately 13.5 V: | | | | White: | 440 lm and 15 lm | |
| | | | | Red: | 105 lm and 4 lm | |

^{1/} These dimensions shall be checked by means of a "Boxsystem"³ based on the dimensions and tolerances shown above. "x" and "y" refer to the major (high wattage) filament, not to the reference axis. Means of increasing the positioning accuracy of the filament and of the cap-holder assembly are under consideration.

^{2/} Maximum lateral deviation of the major filament centre from two mutually perpendicular planes both containing the reference axis and one containing the axis of the reference pin.

^{3/} The "Box system" is the same as for filament light source P21/5W; see sheets P21/5W/2 to 3.

^{4/} The 24-volt filament light source is not recommended for future embodiments.

^{5/} The light emitted from normal production filament light sources shall be red (see also footnote 6/).

^{6/} The light emitted from standard filament light sources shall be white or red.

The drawings are intended only to illustrate the essential dimensions (in mm) of the filament light source.

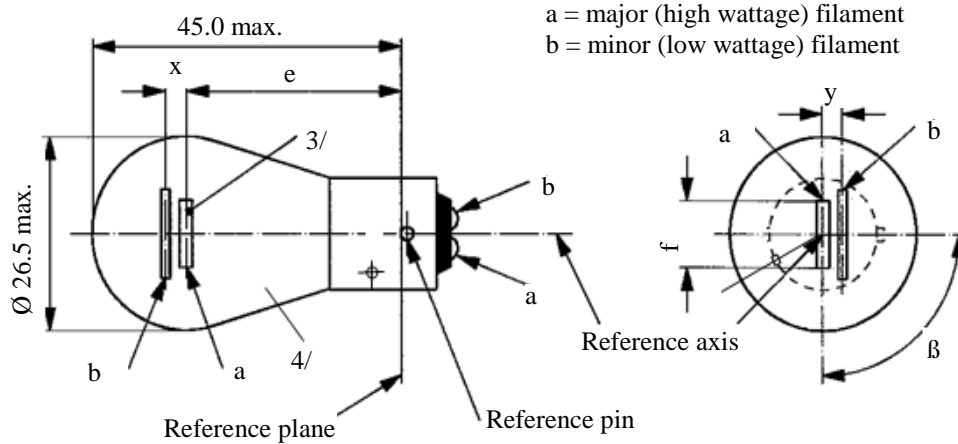

| Dimensions in mm | | Filament light sources of normal production ^{4/} | | | Standard filament light source ^{5/} | |
|--|--------------------|---|--------------------|---------------|--|-------------------|
| | | Min. | Nom. | Max. | | |
| e | 12 V | | 31.8 ^{1/} | | 31.8 ± 0.3 | |
| | 24 V | 30.8 | 31.8 | 32.8 | | |
| f | 12 V | | | 7.0 | 7.0 + 0 / -2 | |
| Lateral deviation ^{2/} | 12 V | | | ^{1/} | 0.3 max. | |
| | 24 V | | | 1.5 | | |
| x, y | 12 V | | ^{1/} | | 2.8 ± 0.3 | |
| x | 24 V ^{3/} | -1.0 | 0 | 1.0 | | |
| y | 24 V ^{3/} | 1.8 | 2.8 | 3.8 | | |
| β | | 75° | 90° | 105° | 90° ± 5° | |
| Cap BAW15d in accordance with IEC Publication 60061 (sheet 7004-11E-1) | | | | | | |
| Electrical and photometric characteristics | | | | | | |
| Rated values | Volts | 12 | | 24 | | 12 |
| | Watts | 21 | 5 | 21 | 5 | 21/5 |
| Test voltage | Volts | 13.5 | | 28.0 | | 13.5 |
| Objective values | Watts | 26.5 max. | 6.6 max. | 29.7 max. | 11.0 max. | 26.5 and 6.6 max. |
| | Luminous flux | 105 | 8 | 105 | 10 | |
| | ± % | 20 | 25 | 20 | 25 | |
| Reference luminous flux at approximately 13.5 V: | | | | White: | 440 lm and 35 lm | |
| | | | | Red: | 105 lm and 8 lm | |

^{1/} See footnote 1/ on sheet P21/5W/2.

^{2/} See footnote 2/ on sheet P21/5W/2.

^{3/} See footnote 3/ on sheet P21/5W/2.

^{4/} The light emitted from normal production filament light sources shall be red (see also footnote 5/).

^{5/} The light emitted from standard filament light sources shall be white or red.

The drawings are intended only to illustrate the essential dimensions (in mm) of the filament light source.

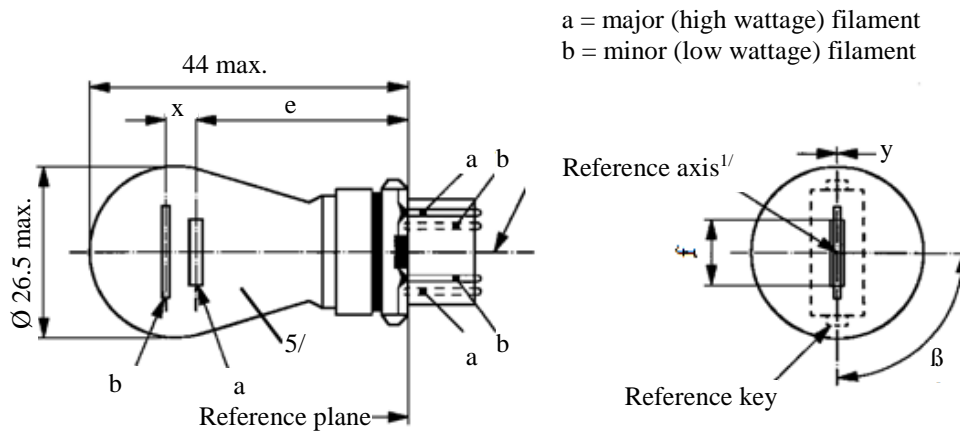

| Dimensions in mm | Filament light sources of normal production | | | Standard filament light source ^{6/} | |
|--|---|--------------------|--------------------|--|---------------|
| | Min. | Nom. | Max. | | |
| e | | 27.9 ^{3/} | | 27.9 ± 0.3 | |
| f | | | 9.9 | 9.9 + 0 / -2 | |
| Lateral deviation ^{2/} | | | ^{3/} | 0.0 ± 0.4 | |
| x ^{4/} | | 5.1 ^{3/} | | 5.1 ± 0.5 | |
| y ^{4/} | | 0.0 ^{3/} | | 0.0 ± 0.5 | |
| β | 75° ^{3/} | 90° | 105° ^{3/} | 90° ± 5° | |
| Cap WU2.5x16q in accordance with IEC Publication 60061 (sheet 7004-104D-1) | | | | | |
| Electrical and photometric characteristics | | | | | |
| Rated values | Volts | 12 | | 12 | |
| | Watts | 27 | 7 | 27 | 7 |
| Test voltage | Volts | 13.5 | | 13.5 | |
| Objective values | Watts | 32.1 max. | 8.5 max. | 32.1 max. | 8.5 max. |
| | Luminous flux | 110 ± 20 % | 9 ± 20 % | | |
| Reference luminous flux at approximately 13.5 V: | | | | White: | 475 and 36 lm |
| | | | | Red: | 110 and 9 lm |

^{1/} The reference axis is defined with respect to the reference keys and is perpendicular to the reference plane.
^{2/} Maximum lateral deviation of the major (high wattage) filament centre from two mutually perpendicular planes both containing the reference axis and one containing the axis through the reference keys.
^{3/} To be checked by means of a "Box system", sheets P27/7W/2 and 3.
^{4/} "x" and "y" denote the offset of the axis of the minor (low wattage) filament with respect to the axis of the major (high wattage) filament.
^{5/} The light emitted from normal production filament light sources shall be red (see also footnote 6/).
^{6/} The light emitted from standard filament light sources shall be white or red.

The drawings are intended only to illustrate the essential dimensions (in mm) of the filament light source.

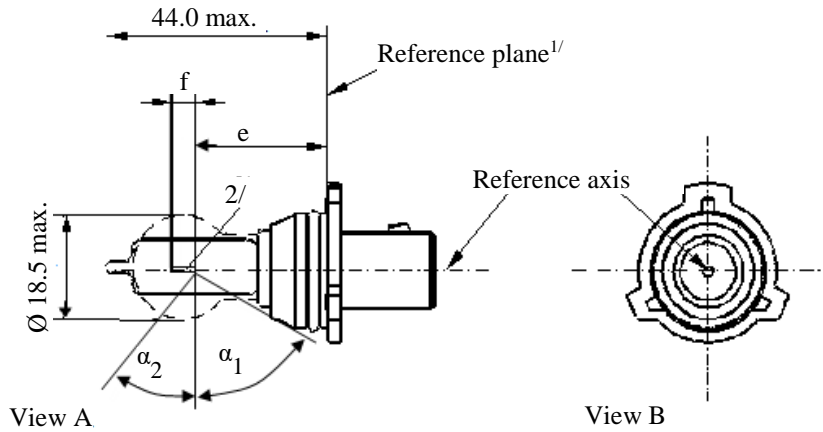

Figure 1 – Main drawing

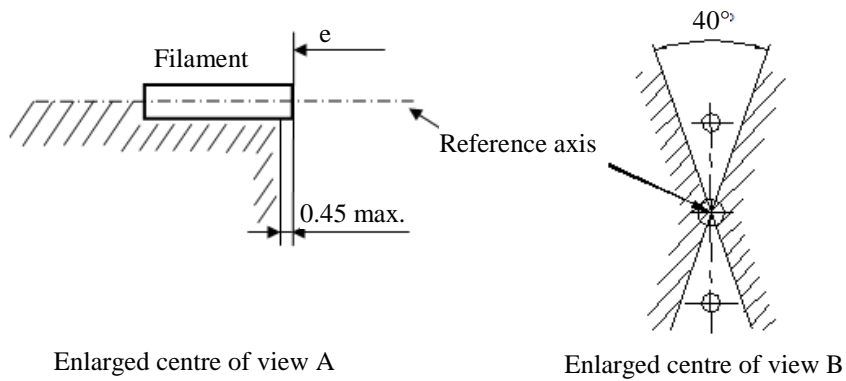

Figure 2 – Metal free zone^{3/}

^{1/} The reference plane is defined by the meeting points of the cap-holder fit.

^{2/} No actual filament diameter restrictions apply but the objective is $d_{max.} = 1.1$ mm.

^{3/} No opaque parts other than filament turns shall be located in the shaded area indicated in Figure 2. This applies to the rotational body within the angles $\alpha_1 + \alpha_2$.

Category PSX26W

Sheet PSX26W/2

| Dimensions in mm | | Filament light sources of normal production | Standard filament light source | |
|---|---------------|---|--------------------------------|---------|
| e ^{5/} | | 24.0 ^{4/} | 24.0 ± 0.25 | |
| f ^{5/} | | 4.2 ^{4/} | 4.2 ± 0.25 | |
| α ₁ ^{6/} | | 35.0° min. | 35.0° min. | |
| α ₂ ^{6/} | | 58.0° min. | 58.0° min. | |
| Cap PG18.5d-3 in accordance with IEC Publication 60061 (sheet 7004-147-1) | | | | |
| Electrical and photometric characteristics | | | | |
| Rated values | Voltage | V | 12 | 12 |
| | Wattage | W | 26 | 26 |
| Test voltage | | V | 13.5 | 13.5 |
| Objective values | Wattage | W | 26 max. | 26 max. |
| | Luminous flux | lm | 500 | |
| | | ± | +10 % / -10 % | |
| Reference luminous flux at approximately 12 V | | | | 345 lm |
| Reference luminous flux at approximately 13.2 V | | | | 465 lm |
| Reference luminous flux at approximately 13.5 V | | | | 500 lm |

^{4/} To be checked by means of a "Box system"; sheet PSX26W/3.

^{5/} The ends of the filament are defined as the points where, when the viewing direction is perpendicular to the plane through the filament lead-in wires, the projection of the outside of the end turns crosses the filament axis.

^{6/} No part of the cap beyond the reference plane shall interfere with angle α₂ as shown in Figure 1 on sheet PSX26W/1. The bulb shall be optically distortion free within the angles α₁+ α₂.
These requirements apply to the whole bulb circumference.

Screen projection requirements

This test is used to determine, by checking whether the filament is correctly positioned relative to the reference axis and reference plane, whether a filament light source complies with the requirements.

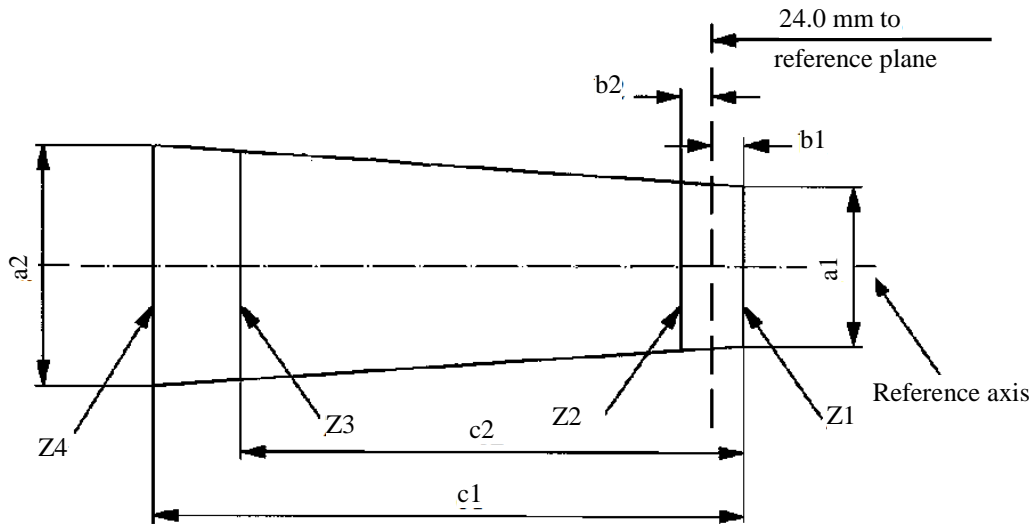

| | a_1 | a_2 | b_1, b_2 | c_1 | c_2 |
|---|-------|-------|------------|-------|-------|
| Filament light sources of normal production | 1.7 | 1.7 | 0.30 | 5.0 | 4.0 |
| Standard filament light sources | 1.5 | 1.5 | 0.25 | 4.7 | 4.0 |

The filament position is checked in two mutually perpendicular planes, one of them being the plane through the lead-in wires.

The ends of the filament as defined on sheet PSX26W/2, footnote 4/, shall lie between Z_1 and Z_2 and between the lines Z_3 and Z_4 .

The filament shall lie entirely within the limits shown.

The drawings are intended only to illustrate the essential dimensions (in mm) of the filament light source.

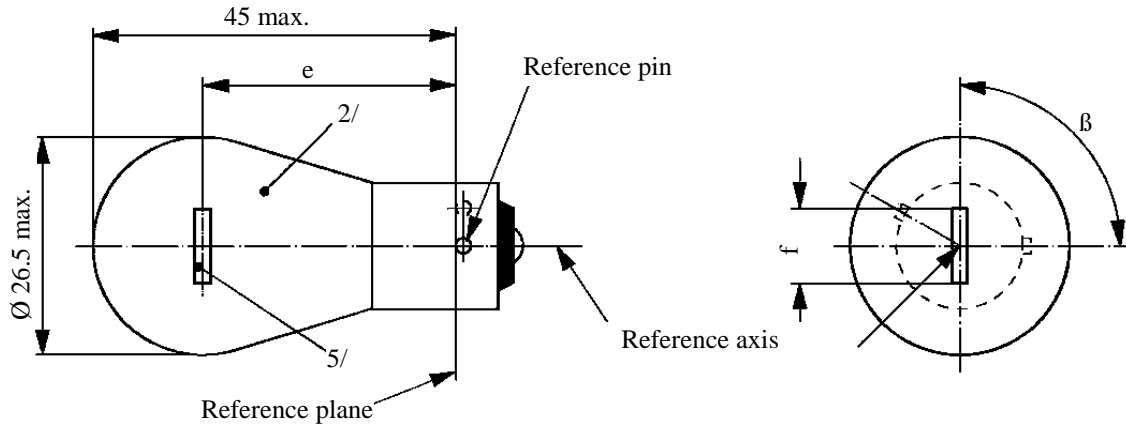

| Dimensions in mm | | Filament light sources of normal production | | | Standard filament light source ^{4/} |
|---|---------------|---|--------------------|---------------|--|
| | | Min. | Nom. | Max. | |
| e | 12 V | | 31.8 ^{3/} | | 31.8 ± 0.3 |
| | 24 V | 30.8 | 31.8 | 32.8 | |
| f | 12 V | | | 7.0 | 7.0 +0 / -2 |
| Lateral deviation ^{1/} | 12 V | | | ^{3/} | 0.3 max. |
| | 24 V | | | 1.5 | |
| β | | 75° | 90° | 105° | 90° ± 5° |
| Cap BAU15s in accordance with IEC Publication 60061 (sheet 7004-19-2) | | | | | |
| Electrical and photometric characteristics | | | | | |
| Rated values | Volts | 12 | 24 | | 12 |
| | Watts | | 21 | | 21 |
| Test voltage | Volts | 13.5 | 28.0 | | 13.5 |
| Objective values | Watts | 26.5 max. | 29.7 max. | | 26.5 max. |
| | Luminous flux | 280 ± 20 % | | | |
| Reference luminous flux at approximately 13.5 V: | | | | | White: 460 lm Amber: 280 lm |

^{1/} Maximum lateral deviation of filament centre from two mutually perpendicular planes both containing the reference axis and one containing the axis of the reference pin.
^{2/} The light emitted from production filament light sources shall be amber (see also footnote 4/).
^{3/} To be checked by means of a "Box system"; sheet P21W/2.
^{4/} The light emitted from standard filament light sources shall be amber or white.
^{5/} In this view the filament of the 24 V type may be straight or V-shaped. If it is straight, the screen projection requirements, sheet P21W/2, apply. If it is V-shaped, the filament ends shall be at the same distance within ±3 mm from the reference plane.

The drawings are intended only to illustrate the essential dimensions (in mm) of the filament light source.

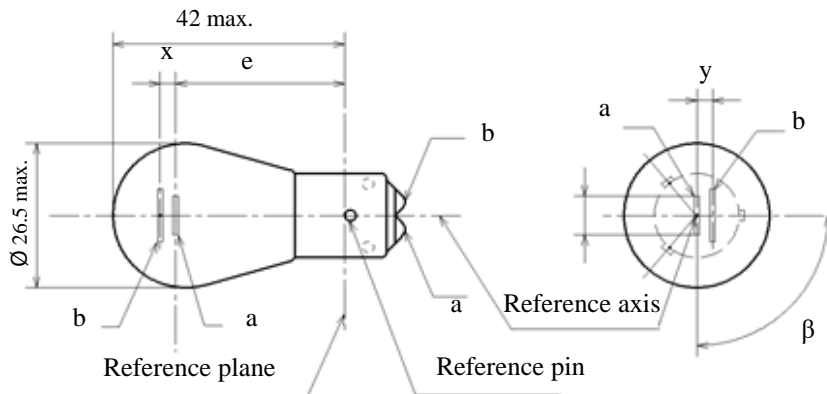

| Dimensions in mm | Filament light sources of normal production ^{3/} | | | Standard filament light source ^{4/} |
|---|---|--------------------|---------------|--|
| | Min. | Nom. | Max. | |
| e | | 28.6 ^{1/} | | 28.6 ± 0.3 |
| f | | | 7.0 | 7.0 + 0/- 2 |
| Lateral deviation ^{2/} | | | ^{1/} | 0.3 max. |
| x, y | | ^{1/} | | 2.8 ± 0.3 |
| β | 75° | 90° | 105° | 90° ± 5° |
| Cap BA15d-3 (100°/130°) in accordance with IEC Publication 60061 (sheet 7004-173-1) | | | | |
| Electrical and photometric characteristics | | | | |
| Rated values | Volts | 12 | | 12 |
| | Watts | 21 | 5 | 21/5 |
| Test voltage | Volts | 13.5 | | 13.5 |
| Objective values | Watts | 26.5 max. | 6.6 max. | 26.5 and 6.6 max. |
| | Luminous flux | 270 | 21 | |
| | ± % | 20 | 20 | |
| Reference luminous flux at approximately 13.5 V | | | | White: 440 lm and 35 lm Amber: 270 lm and 21 lm |

^{1/} These dimensions shall be checked by means of a "Box system". See sheets PY21/5W/2 and PY21/5W/3. "x" and "y" refer to the major (high wattage) filament, not to the reference axis.

^{2/} Maximum lateral deviation of the major (high wattage) filament centre from two mutually perpendicular planes both containing the reference axis and one containing the axis of the reference pin.

^{3/} The light emitted from normal production filament light sources shall be amber (see also note 4/).

^{4/} The light emitted from standard filament light sources shall be white or amber.

Screen projection requirements

This test is used to determine, by checking whether:

- (a) The major (high wattage) filament is correctly positioned relative to the reference axis and reference plane and has an axis perpendicular, within $\pm 15^\circ$, to the plane through the centres of the pins and the reference axis; and whether
- (b) The minor (low wattage) filament is correctly positioned relative to the major (high wattage) filament, whether a filament light source complies with the requirements.

Test procedure and requirements

1. The filament light source is placed in a holder capable of being rotated about its axis and having either a calibrated scale or fixed stops corresponding to the angular displacement tolerance limits. (i.e. 15°). The holder is then so rotated that an end view of the major filament is seen on the screen on which the image of the filament is projected. The end view of that filament shall be obtained within the angular displacement tolerance limits.
2. Side elevation

The filament light source placed with the cap down, the reference axis vertical, the reference pin to the right and the major filament seen end-on:

 - 2.1. The projection of the major filament shall lie entirely within a rectangle of height "a" and width "b", having its centre at the theoretical position of the centre of the filament;
 - 2.2. The projection of the minor filament shall lie entirely:
 - 2.2.1. Within a rectangle of width "c" and height "d" having its centre at a distance "v" to the right of and at a distance "u" above the theoretical position of the centre of the major filament;
 - 2.2.2. Above a straight line tangential to the upper edge of the projection of the major filament and rising from left to right at an angle of 25° .
 - 2.2.3. To the right of the projection of the major filament
3. Front elevation

The filament light source being placed with the cap down and the reference axis vertical, the filament light source being viewed in a direction at right angles to axis of the major filament:

 - 3.1. The projection of the major filament shall lie entirely within a rectangle of height "a" and width "h", centred on the theoretical position of the centre of the filament;
 - 3.2. The centre of the major filament shall not be offset by more than distance "k" from the reference axis.
 - 3.3. The centre of the minor filament axis shall not be offset from the reference axis by more than ± 2 mm (± 0.4 mm for standard filament light sources).

Dimensions in mm

Side elevation

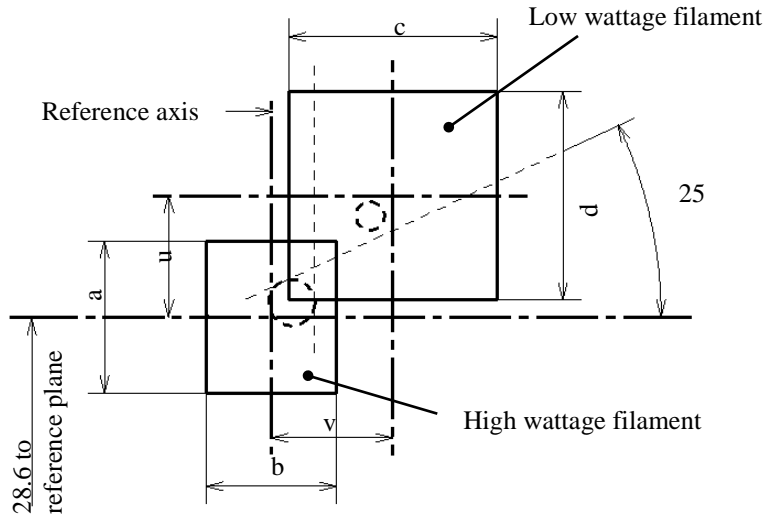

| Reference | a | b | c | d | u | v |
|------------|-----|-----|-----|---|-----|---|
| Dimensions | 3.5 | 3.0 | 4.8 | | 2.8 | |

Front elevation

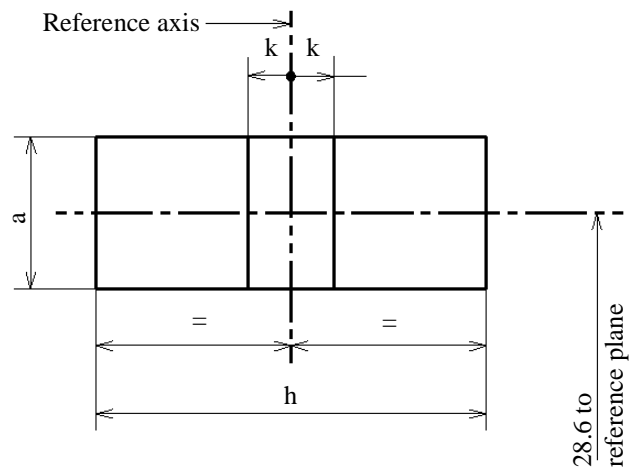

| Reference | a | h | k |
|------------|-----|-----|-----|
| Dimensions | 3.5 | 9.0 | 1.0 |

The drawings are intended only to illustrate the essential dimensions (in mm) of the filament light source.

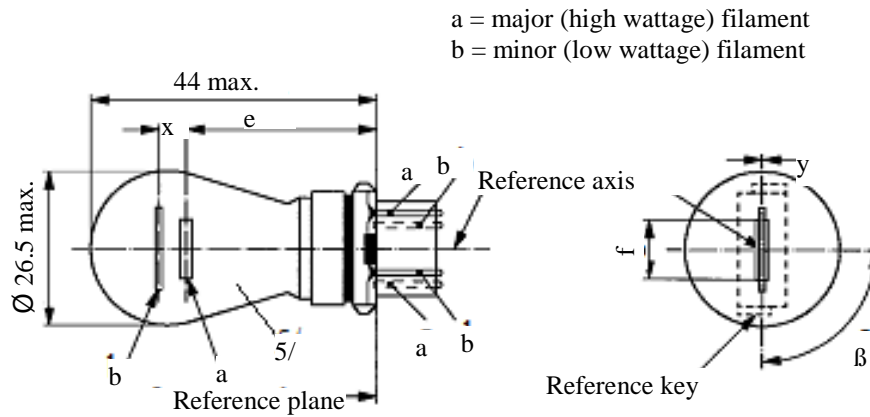

| Dimensions in mm | Filament light sources of normal production | | | Standard filament light source ^{6/} | |
|--|---|--------------------|--------------------|--|----------|
| | Min. | Nom. | Max. | | |
| e | | 27.9 ^{3/} | | 27.9 ± 0.3 | |
| f | | | 9.9 | 9.9 + 0 / -2 | |
| Lateral deviation ^{2/} | | | ^{3/} | 0.0 ± 0.4 | |
| x ^{4/} | | 5.1 ^{3/} | | 5.1 ± 0.5 | |
| y ^{4/} | | 0.0 ^{3/} | | 0.0 ± 0.5 | |
| β | 75° ^{3/} | 90° | 105° ^{3/} | 90° ± 5° | |
| Cap WX2.5x16q in accordance with IEC Publication 60061 (sheet 7004-104A-1) | | | | | |
| Electrical and photometric characteristics | | | | | |
| Rated values | Volts | 12 | | 12 | |
| | Watts | 27 | 7 | 27 | 7 |
| Test voltage | Volts | 13.5 | | 13.5 | |
| Objective values | Watts | 32.1 max. | 8.5 max. | 32.1 max. | 8.5 max. |
| | Luminous flux | 280 ± 15 % | 21 ± 15 % | | |
| Reference luminous flux at approximately 13.5 V: | | | | White: 475 and 36 lm Amber: 280 and 21 lm | |

^{1/} The reference axis is defined with respect to the reference keys and is perpendicular to the reference plane.

^{2/} Maximum lateral deviation of the major (high wattage) filament centre from two mutually perpendicular planes both containing the reference axis and one containing the axis through the reference keys.

^{3/} To be checked by means of a "Box system", sheets P27/7W/2 and 3.

^{4/} "x" and "y" denote the offset of the axis of the minor (low wattage) filament with respect to the axis of the major (high wattage) filament.

^{5/} The light emitted from filament light sources of normal production shall be amber (see also footnote 6/).

^{6/} The light emitted from standard filament light sources shall be amber or white.

The drawings are intended only to illustrate the essential dimensions (in mm) of the filament light source.

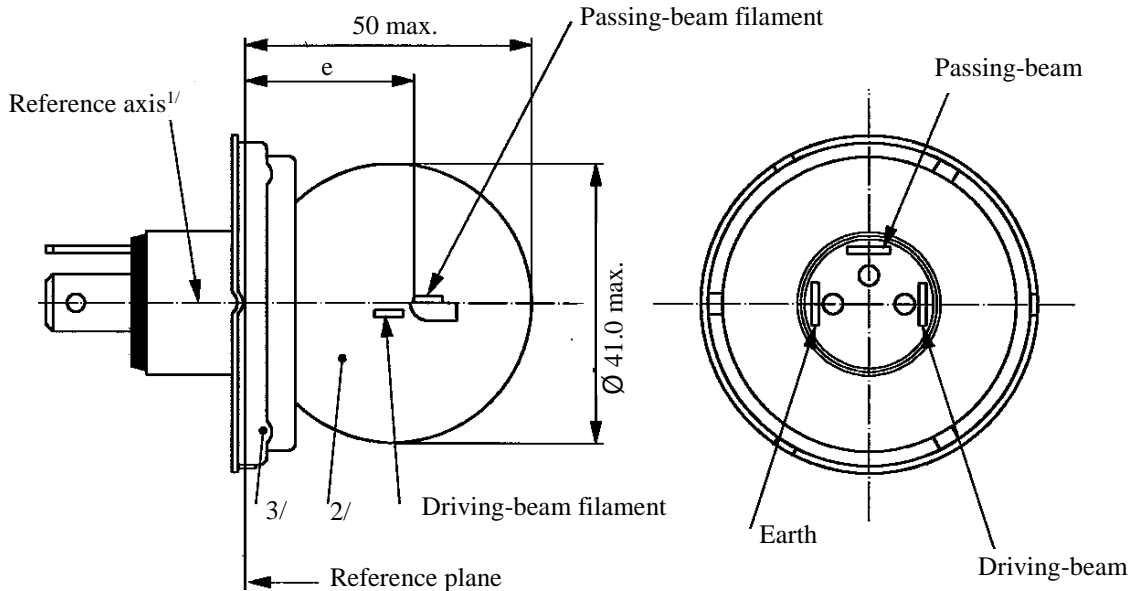

| <i>Electrical and photometric characteristics</i> | | | | | | | | | |
|---|---------------|--|--------------|------------------|--------------|------------------|--------------|---------------------------------------|------------|
| | | <i>Filament light sources of normal production</i> | | | | | | <i>Standard filament light source</i> | |
| Rated values | Volts | 6 ^{4/} | | 12 ^{4/} | | 24 ^{4/} | | 12 ^{4/} | |
| | Watts | 45 | 40 | 45 | 40 | 55 | 50 | 45 | 40 |
| Test voltage | Volts | 6.3 | | 13.2 | | 28.0 | | 13.2 | |
| Objective values | Watts | 53 max. | 47 max. | 57 max. | 51 max. | 76 max. | 69 max. | 52 +0 % -10 % | 46 ±5 % |
| | Luminous flux | 720 min. | 570 ±15 % | 860 min. | 675 ±15 % | 1,000 min. | 860 ±15 % | | |
| Measuring flux ^{5/} | | - | 450 | - | 450 | - | 450 | | |
| Reference luminous flux at approximately 12 V | | | | | | | | 700 | 450 |

^{1/} The reference axis is perpendicular to the reference plane and passes through the centre of the 45 mm cap diameter.
^{2/} The colour of the light emitted shall be white or selective-yellow.
^{3/} No part of the cap shall, by reflection of light emitted by the passing-beam filament, throw any stray rising ray when the filament light source is in the normal operating position on the vehicle.
^{4/} The values indicated on the left and on the right refer to the driving-beam filament and the passing-beam filament respectively.
^{5/} Measuring luminous flux according to the provisions for filament light sources with an internal shield to produce the cut-off.

Position and dimensions (in mm) of shield and filaments

The drawings are not mandatory with respect to the design of the shield and filaments.

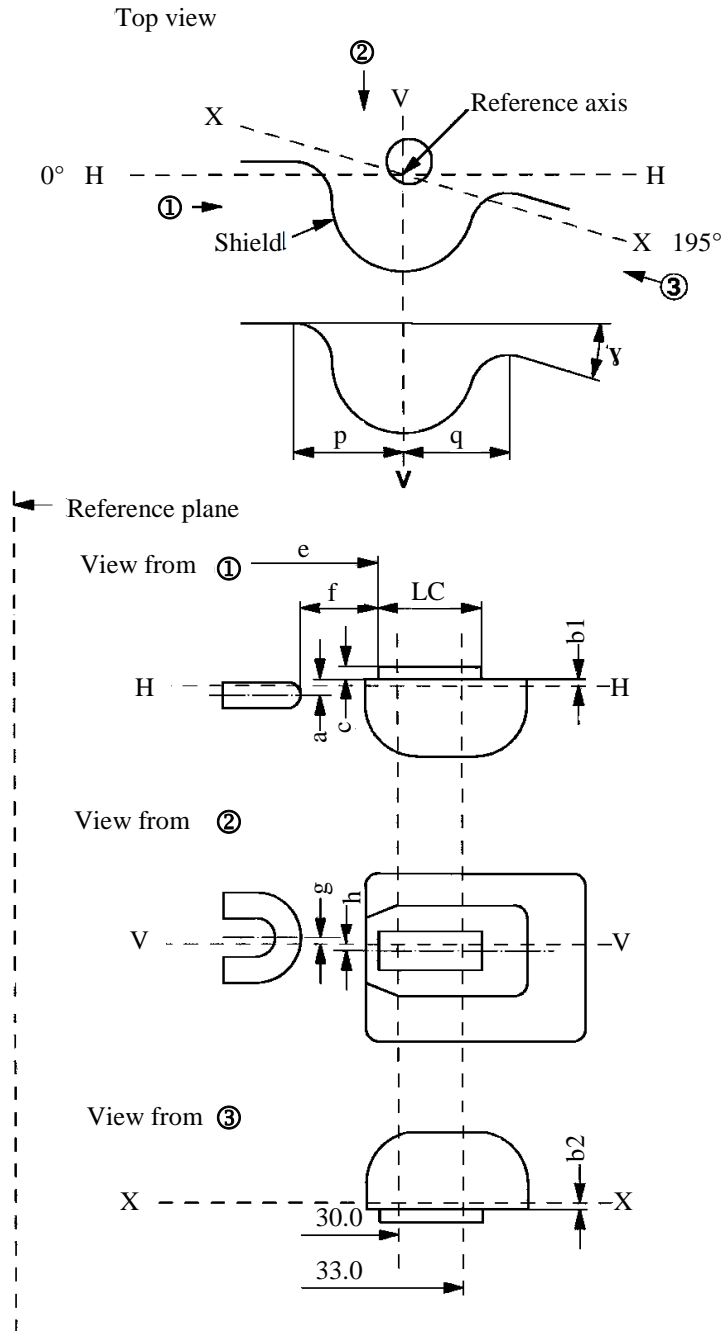

| <i>Filaments and shield position and dimensions</i> ^{1/} | | | | | |
|--|---------|--|-------------|---------------------------------------|-------------|
| <i>Dimensions in mm</i> | | <i>Tolerance</i> | | | |
| | | <i>Filament light sources of normal production</i> | | <i>Standard filament light source</i> | |
| | | <i>6 V</i> | <i>12 V</i> | <i>24 V</i> | <i>12 V</i> |
| a | | 0.60 | ±0.35 | | ±0.15 |
| b1/30.0 ^{2/} | | 0.20 | ±0.35 | | ±0.15 |
| b1/33.0 | | b1/30.0 mv ^{3/} | | | |
| b2/30.0 ^{2/} | | 0.20 | ±0.35 | | ±0.15 |
| b2/33.0 | | b2/30.0 mv ^{3/} | | | |
| c/30.0 ^{2/} | | 0.50 | ±0.30 | | ±0.15 |
| c/33.0 | | c/30.0 mv ^{3/} | | | |
| e | 6, 12 V | 28.5 | ±0.35 | | ±0.15 |
| | 24 V | 28.8 | | | |
| f | 6, 12 V | 1.8 | ±0.40 | | ±0.20 |
| | 24 V | 2.2 | | | |
| g | | 0 | ±0.50 | | ±0.30 |
| h/30.0 ^{2/} | | 0 | ±0.50 | | ±0.30 |
| h/33.0 | | h/30.0 mv ^{3/} | | | |
| 1/2(p-q) | | 0 | ±0.60 | | ±0.30 |
| I _c | | 5.5 | ±1.50 | | ±0.50 |
| γ ^{4/} | | 15° nom. | | | |
| Cap P45t-41 in accordance with IEC Publication 60061 (sheet 7004-95-5) | | | | | |

^{1/} The position and dimensions of the shield and filaments shall be checked by means of the method of measurement as described in IEC Publication 60809.

^{2/} To be measured at the distance from the reference plane indicated in millimetres behind the stroke.

^{3/} mv = measured value.

^{4/} The angle γ is only for shield design and has not to be checked on finished filament light sources.

Category R5W and RR5W

Sheet R5W/1

The drawings are intended only to illustrate the essential dimensions (in mm) of the filament light source.

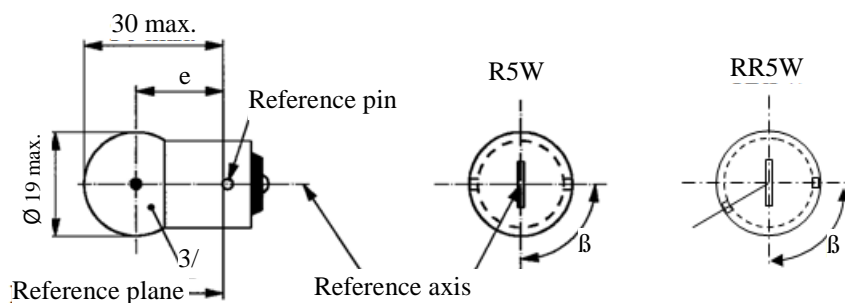

| Dimensions in mm | | Filament light sources of normal production | | | Standard filament light source ^{4/} |
|--|----------------------------|---|---------------|-----------|--|
| | | Min. | Nom. | Max. | |
| e | | 17.5 | 19.0 | 20.5 | 19.0 ± 0.3 |
| Lateral deviation ^{2/} | | | | 1.5 | 0.3 max. |
| β | | 60° | 90° | 120° | 90° ± 5° |
| Cap: | R5W: BA15s RR5W: BAW15s | in accordance with IEC Publication 60061 | | | (sheet 7004-11A-9) ^{1/} (sheet 7004-11E-1) |
| Electrical and photometric characteristics | | | | | |
| Rated values | Volts | 6 ^{5/} | 12 | 24 | 12 |
| | Watts | 5 | | | 5 |
| Test voltage | Volts | 6.75 | 13.5 | 28.0 | 13.5 |
| Objective values | Watts | 5.5 max. | | 7.7 max. | 5.5 max. |
| | Luminous flux | R5W | 50 ± 20 % | | |
| | | RR5W | ^{5/} | 12 ± 25 % | |
| Reference luminous flux at approximately 13.5 V: | | | | | White: 50 lm Red: 12 lm |

^{1/} Filament light sources with cap BA15d may be used for special purposes; they have the same dimensions.

^{2/} Maximum lateral deviation of filament centre from two mutually perpendicular planes both containing the reference axis and one containing the axis of the reference pin.

^{3/} The light emitted from filament light sources of normal production shall be white for category R5W and red for category RR5W (see also footnote 4/).

^{4/} The light emitted from standard filament light sources shall be white for category R5W; white or red for category RR5W.

^{5/} Within RR5W no 6 V rated voltage type specified.

The drawings are intended only to illustrate the essential dimensions (in mm) of the filament light source.

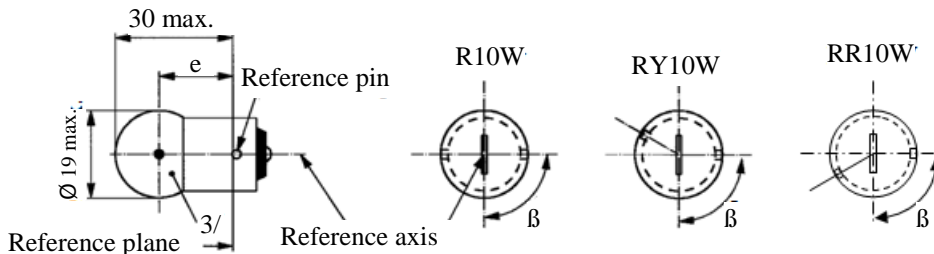

| Dimensions in mm | | Filament light sources of normal production | | | Standard filament light source ^{4/} | |
|--|---|---|---------------|---------|---|---------|
| | | Min. | Nom. | Max. | | |
| e | | 17.5 | 19.0 | 20.5 | 19.0 ± 0.3 | |
| Lateral deviation ^{2/} | | | | 1.5 | 0.3 max. | |
| β | | 60° | 90° | 120° | 90° ± 5° | |
| Cap | R10W: BA15s RY10W: BAU15s RR10W: BAW15s | in accordance with IEC Publication 60061 | | | (sheet 7004-11A-9) ^{1/} (sheet 7004-19-2) (sheet 7004-11E-1) | |
| Electrical and photometric characteristics | | | | | | |
| Rated values | Volts | 6 ^{5/} | 12 | 24 | 12 | |
| | Watts | 10 | | | 10 | |
| Test voltage | Volts | 6.75 | 13.5 | 28 | 13.5 | |
| Objective values | Watts | R10W RY10W | 11 max. | | 14 max. | 11 max. |
| | | RR10W | ^{5/} | 11 max. | | 11 max. |
| | Luminous flux | R10W | 125 ± 20 % | | | |
| | | RY10W | 75 ± 20 % | | | |
| | RR10W | ^{5/} | 30 ± 25 % | | | |
| Reference luminous flux at approximately 13.5 V: | | | | | White: 125 lm Amber: 75 lm Red: 30 lm | |

^{1/} Filament light sources R10W with cap BA15d may be used for special purposes; they have the same dimensions.

^{2/} Maximum lateral deviation of filament centre from two mutually perpendicular planes both containing the reference axis and one containing the axis of the reference pin.

^{3/} The light emitted from filament light sources of normal production shall be white for category R10W, amber for category RY10W and red for category RR10W (see also footnote 4/)

^{4/} The light emitted from standard filament light sources shall be white for category R10W; white or amber for category RY10W; white or red for category RR10W.

^{5/} Within RR10W no 6 V rated voltage type specified.

Categories S1 and S2

Sheet S1/S2/1

The drawings are intended only to illustrate the essential dimensions (in mm) of the filament light source.

Filament lamps for motorcycles

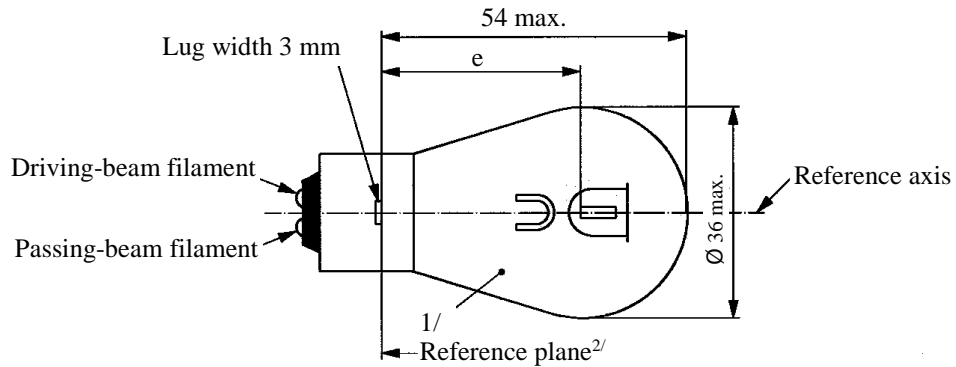

Position and dimensions of filaments

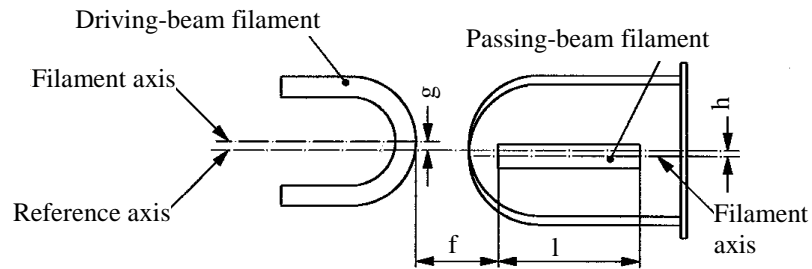

Position of shield^{3/4/}

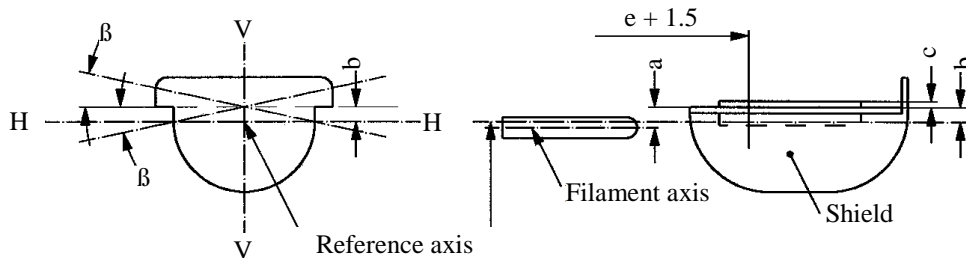

^{1/} The colour of the light emitted shall be white or selective-yellow.

^{2/} The reference plane is perpendicular to the reference axis and touches the upper surface of the lug having a width of 4.5 mm.

^{3/} Plane V-V contains the reference axis and the centre line of the lugs.

^{4/} Plane H-H (the normal position of the shield) is perpendicular to plane V-V and contains the reference axis.

| Dimensions in mm | | Filament light sources of normal production | | | | Standard filament light source | | |
|--|---------------|---|------------------|------------|------------------|--------------------------------|----------|----------|
| | | Min. | Nom. | Max. | | | | |
| e | | 32.35 | 32.70 | 33.05 | 32.7 ± 0.15 | | | |
| f | | 1.4 | 1.8 | 2.2 | 1.8 ± 0.2 | | | |
| l | | 4.0 | 5.5 | 7.0 | 5.5 ± 0.5 | | | |
| c ^{5/} | | 0.2 | 0.5 | 0.8 | 0.5 ± 0.15 | | | |
| b ^{5/} | | -0.15 | 0.2 | 0.55 | 0.2 ± 0.15 | | | |
| a ^{5/} | | 0.25 | 0.6 | 0.95 | 0.6 ± 0.15 | | | |
| h | | -0.5 | 0 | 0.5 | 0 ± 0.2 | | | |
| g | | -0.5 | 0 | 0.5 | 0 ± 0.2 | | | |
| β ^{5/, 6/} | | -2°30' | 0° | +2°30' | 0° ± 1° | | | |
| Cap BA20d in accordance with IEC Publication 60061 (sheet 7004-12-7) | | | | | | | | |
| Electrical and photometric characteristics | | | | | | | | |
| Rated values | Volts | S1 | 6 ^{7/} | | 12 ^{7/} | | 6 | |
| | | S2 | | | | | 12 | |
| | Watts | S1 | 25 | 25 | 25 | 25 | 25 | 25 |
| | | S2 | 35 | 35 | 35 | 35 | 35 | 35 |
| Test voltage | Volts | S1 | 6.75 | | 13.5 | | 6.75 | |
| | | S2 | 6.3 | | 13.5 | | 13.5 | |
| Objective values | Watts | S1 | 25 ± 5 % | 25 ± 5 % | 25 ± 5 % | 25 ± 5 % | 25 ± 5 % | 25 ± 5 % |
| | | S2 | 35 ± 5 % | 35 ± 5 % | 35 ± 5 % | 35 ± 5 % | 35 ± 5 % | 35 ± 5 % |
| | Luminous flux | S1 | 435 ± 20 % | 315 ± 20 % | 435 ± 20 % | 315 ± 20 % | | |
| | | S2 | 650 ± 20 % | 465 ± 20 % | 650 ± 20 % | 465 ± 20 % | | |
| Reference luminous flux | | S1 | at approximately | | | 6 V | 398 | 284 |
| | | | | | | 12 V | 568 | 426 |
| | | S2 | at approximately | | | 13.2 V | 634 | 457 |
| | | | | | | 13.5 V | 650 | 465 |

^{5/} Dimensions a, b, c and β refer to a plane parallel to the reference plane and cutting the two edges of the shield at a distance of e + 1.5 mm.

^{6/} Admissible angular deviation of the shield plane position from the normal position.

^{7/} Values in the left-hand column refer to the driving-beam filament. Values in the right-hand column to the passing-beam filament.

Category S3

Sheet S3/1

The drawings are intended only to illustrate the essential dimensions (in mm) of the filament light source.

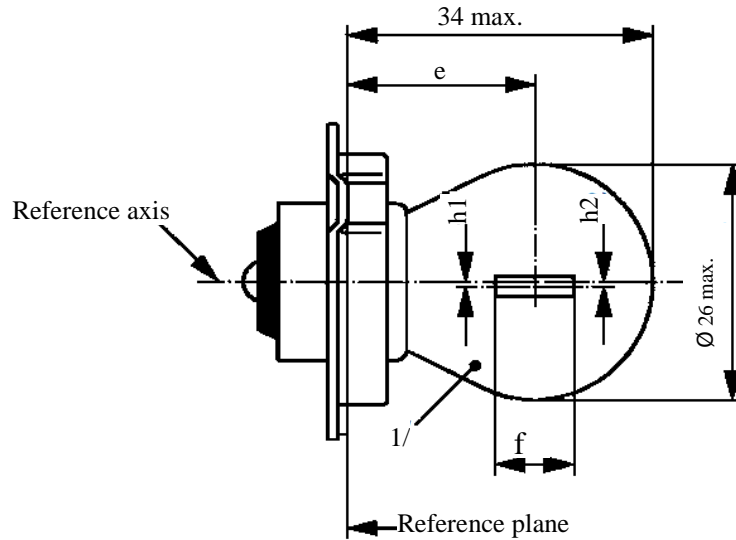

| Dimensions in mm | | Filament light sources of normal production | | | Standard filament light source |
|---|---------------|---|------|------|--------------------------------|
| | | Min. | Nom. | Max. | |
| e ^{2/} | | 19.0 | 19.5 | 20.0 | 19.5 ± 0.25 |
| f | 6 V | | | 3.0 | 2.5 ± 0.5 |
| | 12 V | | | 4.0 | |
| h1, h2 ^{3/} | | -0.5 | 0 | 0.5 | 0 ± 0.3 |
| Cap P26s in accordance with IEC Publication 60061 (sheet 7004-36-1) | | | | | |
| Electrical and photometric characteristics | | | | | |
| Rated values | Volts | 6 | 12 | 6 | |
| | Watts | 15 | | | 15 |
| Test voltage | Volts | 6.75 | 13.5 | 6.75 | |
| Objective values | Watts | 15 ± 6 % | | | 15 ± 6 % |
| | Luminous flux | 240 ± 15 % | | | |
| Reference luminous flux: 240 lm at approximately 6.75 V | | | | | |

^{1/} The colour of the light emitted shall be white or selective-yellow.

^{2/} Distance related to the luminous centre.

^{3/} Lateral deviation of filament axis with respect to the reference axis. It is sufficient to check this deviation in two mutually perpendicular planes.

The drawings are intended only to illustrate the essential dimensions (in mm) of the filament light source.

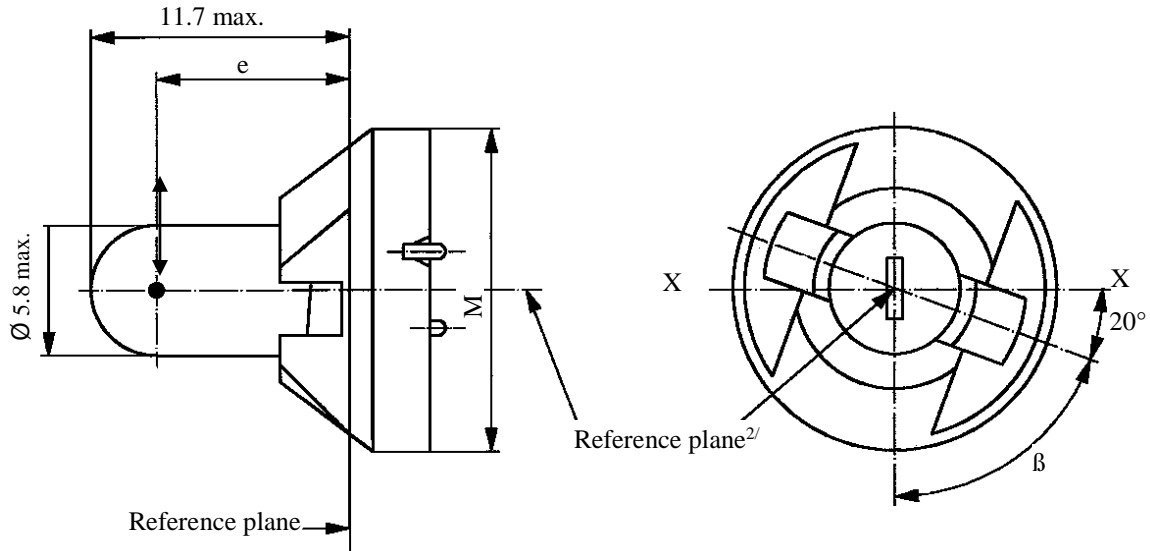

| Dimensions in mm | Filament light sources of normal production | | | Standard filament light source |
|---|---|-----------|------|--------------------------------|
| | Min. | Nom. | Max. | |
| e | 7.6 | 8.3 | 9.0 | 8.3 ± 0.35 |
| Lateral deviation ^{1/} | | | 0.7 | 0.35 max |
| β | 55° | 70° | 85° | $70^\circ \pm 5^\circ$ |
| Cap P11.5d in accordance with IEC Publication 60061 (sheet 7004-79-1) | | | | |
| Electrical and photometric characteristics | | | | |
| Rated values | Volts | 12 | | 12 |
| | Watts | 1.4 | | 1.4 |
| Test voltage | Volts | 13.5 | | 13.5 |
| Objective values | Watts | 1.54 max. | | 1.54 max. |
| | Luminous flux | 8 ± 15 % | | |
| Reference luminous flux: 8 lm at approximately 13.5 V | | | | |

^{1/} Maximum lateral deviation of filament centre from two mutually perpendicular planes both containing the reference axis and one containing axis X-X.

^{2/} The reference axis is perpendicular to the reference plane and passes through the centre of the circle of diameter "M".

Category T4W

Sheet T4W/1

The drawings are intended only to illustrate the essential dimensions (in mm) of the filament light source.

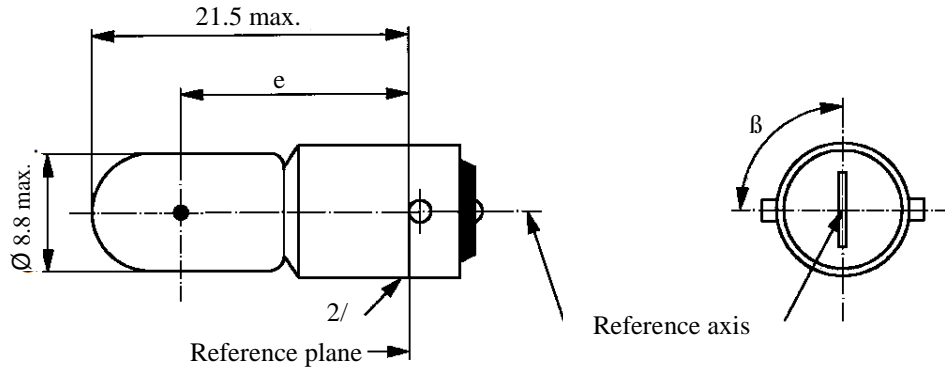

| Dimensions in mm | Filament light sources of normal production | | | Standard filament light source | |
|---|---|-----------|------|--------------------------------|----------|
| | Min. | Nom. | Max. | | |
| e | 13.5 | 15.0 | 16.5 | 15.0 ± 0.3 | |
| Lateral deviation ^{1/} | | | 1.5 | 0.5 max | |
| β | | 90° | | 90° ± 5° | |
| Cap BA9s in accordance with IEC Publication 60061 (sheet 7004-14-9) | | | | | |
| Electrical and photometric characteristics | | | | | |
| Rated values | Volts | 6 | 12 | 24 | 12 |
| | Watts | 4 | | | 4 |
| Test voltage | Volts | 6.75 | 13.5 | 28.0 | 13.5 |
| Objective values | Watts | 4.4 max. | | 5.5 max. | 4.4 max. |
| | Luminous flux | 35 ± 20 % | | | |
| Reference luminous flux: 35 lm at approximately 13.5 V | | | | | |

^{1/} Maximum lateral deviation of filament centre from two mutually perpendicular planes both containing the reference axis and one containing the axis of pins.

^{2/} Over the entire length of the cap there shall be no projections or soldering extending beyond the permissible maximum diameter of the cap.

The drawings are intended only to illustrate the essential dimensions (in mm) of the filament light source.

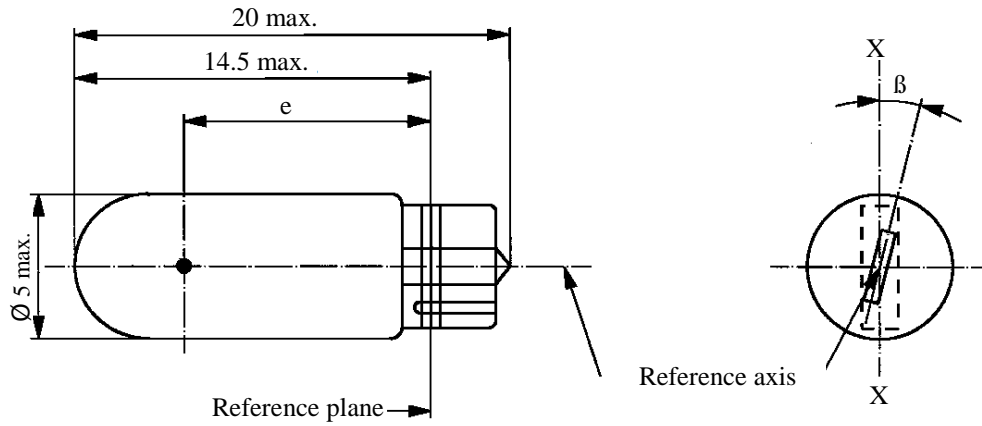

| Dimensions in mm | Filament light sources of normal production | | | Standard filament light source |
|--|---|-----------------|------|--------------------------------|
| | Min. | Nom. | Max. | |
| e | 10.3 | 10.8 | 11.3 | 10.8 ± 0.3 |
| Lateral deviation ^{1/} | | | 1.0 | 0.5 max |
| β | -15° | 0° | +15° | $0^\circ \pm 5^\circ$ |
| Cap W2x4.6d in accordance with IEC Publication 60061 (sheet 7004-94-2) | | | | |
| Electrical and photometric characteristics | | | | |
| Rated values | Volts | 12 | | 12 |
| | Watts | 2.3 | | 2.3 |
| Test voltage | Volts | 13.5 | | 13.5 |
| Objective values | Watts | 2.5 max. | | 2.5 max. |
| | Luminous flux | 18.6 \pm 20 % | | |
| Reference luminous flux: 18.6 lm at approximately 13.5 V | | | | |

^{1/} Maximum lateral deviation of filament centre from two mutually perpendicular planes both containing the reference axis and one containing axis X-X.

The drawings are intended only to illustrate the essential dimensions (in mm) of the filament light source.

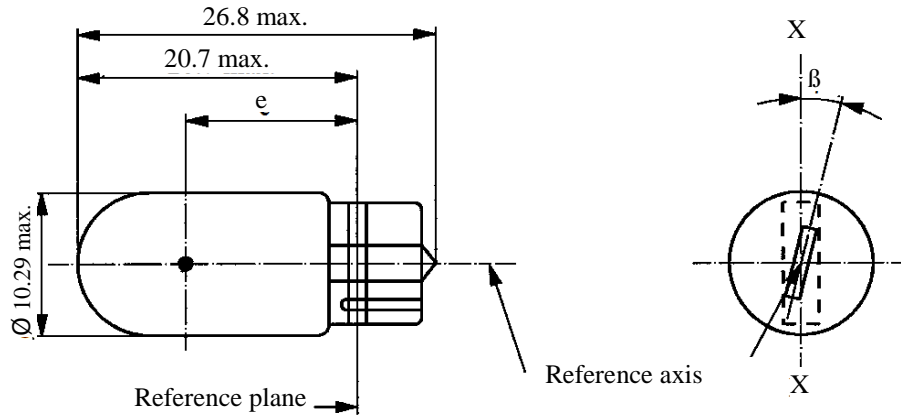

| Dimensions in mm | | Filament light sources of normal production | | | Standard filament light source |
|--|---------------|---|--------|----------|--------------------------------|
| | | Min. | Nom. | Max. | |
| e | | 11.2 | 12.7.0 | 14.2 | 12.7 ± 0.3 |
| Lateral deviation ^{1/} | | | | 1.5 | 0.5 max |
| β | | -15° | 0° | +15° | $0^\circ \pm 5^\circ$ |
| Cap W2.1x9.5d in accordance with IEC Publication 60061 (sheet 7004-91-3) | | | | | |
| Electrical and photometric characteristics | | | | | |
| Rated values | Volts | 6 | 12 | 24 | 12 |
| | Watts | 3 | | | 3 |
| Test voltage | Volts | 6.75 | 13.5 | 28.0 | 13.5 |
| Objective values | Watts | 3.45 max. | | 4.6 max. | 3.45 max. |
| | Luminous flux | 22 \pm 30 % | | | |
| Reference luminous flux: 22 lm at approximately 13.5 V | | | | | |

^{1/} Maximum lateral deviation of filament centre from two mutually perpendicular planes both containing the reference axis and one containing axis X-X.

The drawings are intended only to illustrate the essential dimensions (in mm) of the filament light source.

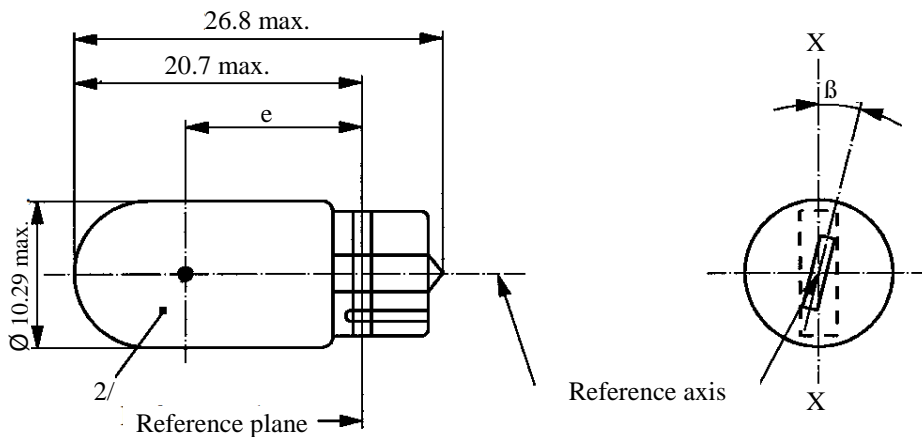

| Dimensions in mm | | Filament light sources of normal production | | | Standard filament light source ^{3/} |
|--|---------------|---|-----------|----------|--|
| | | Min. | Nom. | Max. | |
| e | | 11.2 | 12.7 | 14.2 | 12.7 ± 0.3 |
| Lateral deviation ^{1/} | | | | 1.5 | 0.5 max. |
| β | | -15° | 0° | +15° | 0° ± 5° |
| Cap W2.1x9.5d in accordance with IEC Publication 60061 (sheet 7004-91-3) | | | | | |
| Electrical and photometric characteristics | | | | | |
| Rated values | Volts | 6 ^{4/} | 12 | 24 | 12 |
| | Watts | 5 | | | 5 |
| Test voltage | Volts | 6.75 | 13.5 | 28.0 | 13.5 |
| Objective values | Watts | | 5.5 max. | 7.7 max. | 5.5 max. |
| | Luminous flux | W5W | 50 ± 20 % | | |
| | | WY5W | 30 ± 20 % | | |
| | WR5W | 4/ | 12 ± 25 % | | |
| Reference luminous flux at approximately 13.5 V: | | | | | White: 50 lm Amber: 30 lm Red: 12 lm |

^{1/} Maximum lateral deviation of filament centre from two mutually perpendicular planes both containing the reference axis and one containing axis X-X.
^{2/} The light emitted from filament light sources of normal production shall be white for category W5W, amber for category WY5W and red for category WR5W (see also footnote 3/)
^{3/} The light emitted from standard filament light sources shall be white for category W5W; white or amber for category WY5W; white or red for category WR5W.
^{4/} Within WR5W no 6 V rated voltage type specified.

Categories W10W and WY10W

Sheet W10W/1

The drawings are intended only to illustrate the essential dimensions (in mm) of the filament light source.

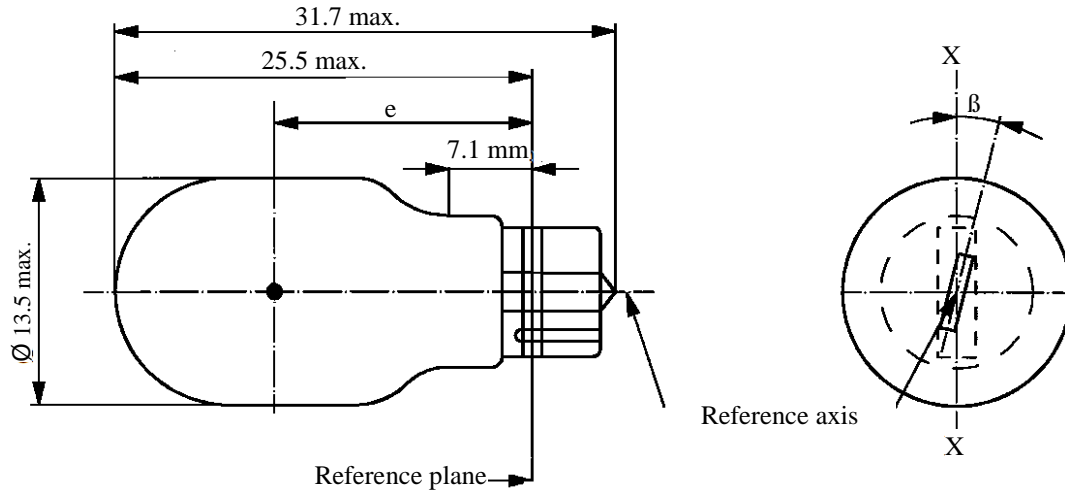

| Dimensions in mm | | Filament light sources of normal production | | | Standard filament light source |
|--|---------------|---|------------|------|--------------------------------|
| | | Min. | Nom. | Max. | |
| e | | 15.5 | 17.0 | 18.5 | 17.0 ± 0.3 |
| Lateral deviation ^{1/} | | | | 1.0 | 0.5 max. |
| β | | -15° | 0° | +15° | 0° ± 5° |
| Cap W2.1x9.5d in accordance with IEC Publication 60061 (sheet 7004-91-3) | | | | | |
| Electrical and photometric characteristics | | | | | |
| Rated values | Volts | 6 | | 12 | 12 |
| | Watts | 10 | | | 10 |
| Test voltage | Volts | 6.75 | | 13.5 | 13.5 |
| Objective values | Watts | 11 max. | | | 11 max. |
| | Luminous flux | White | 125 ± 20 % | | |
| | | Amber | 75 ± 20 % | | |
| Reference luminous flux at approximately 13.5 V: | | | | | White: 125 lm Amber: 75 lm |

^{1/} Maximum lateral deviation of filament centre from two mutually perpendicular planes both containing the reference axis and one containing axis X-X.

The drawings are intended only to illustrate the essential dimensions (in mm) of the filament light source.

a = major (high wattage) filament
 b = minor (low wattage) filament

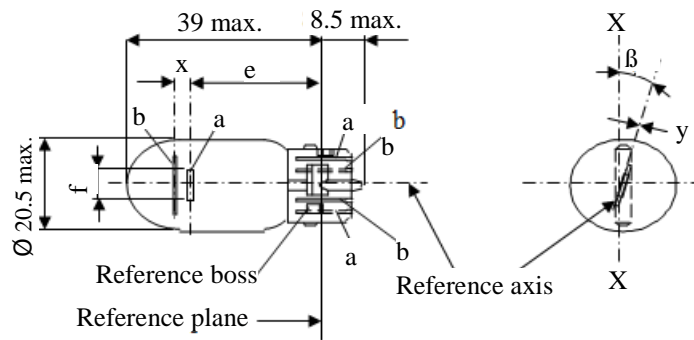

| Dimensions in mm | Filament light sources of normal production | | | Standard filament light source | |
|---|---|--------------------|--------------------|--------------------------------|----------|
| | Min. | Nom. | Max. | | |
| e | | 25.0 ^{1/} | | 25.0 ± 0.3 | |
| f | | | 7.5 | 7.5 + 0 / -2 | |
| Lateral deviation ^{2/} | | | ^{1/} | 0.3 max. | |
| x ^{3/} | | 2.8 ^{1/} | | 2.8 ± 0.3 | |
| y ^{3/} | | 0.0 ^{1/} | | 0.0 ± 0.3 | |
| β | -15° ^{1/} | 0° | +15° ^{1/} | 0° ± 5° | |
| Cap WZ3x16q in accordance with IEC Publication 60061 (sheet 7004-151-2) | | | | | |
| Electrical and photometric characteristics | | | | | |
| Rated values | Volts | 12 | | 12 | |
| | Watts | 15 | 5 | 15 | 5 |
| Test voltage | Volts | 13.5 | | 13.5 | |
| Objective values | Watts | 19.1 max. | 6.6 max. | 19.1 max. | 6.6 max. |
| | Luminous flux | 280 ± 15 % | 35 ± 20 % | | |
| Reference luminous flux: 280 lm and 35 lm at approximately 13.5 V | | | | | |

^{1/} To be checked by means of a "Box system"; sheets W15/5W/2 and 3.

^{2/} Maximum lateral deviation of filament centre from two mutually perpendicular planes both containing the reference axis and one containing axis X-X.

^{3/} "x" and "y" denote the offset of the axis of the minor filament with respect to the axis of the major filament.

Screen projection requirements

This test is used to determine, by checking whether:

- (a) The major filament is correctly positioned relative to the reference axis and reference plane and has an axis perpendicular, within $\pm 15^\circ$, to the plane through the axis X-X and the reference axis; and whether:
- (b) The minor filament is correctly positioned relative to the major filament, whether a filament light source complies with the requirements.

Test procedure and requirements.

1. The filament light source is placed in a holder capable of being rotated about its axis and having either a calibrated scale or fixed stops corresponding to the angular displacement tolerance limits. The holder is then so rotated that an end view of the major filament is seen on the screen on which the image of the filament is projected. The end view of that filament shall be obtained within the angular displacement tolerance limits. ($\pm 15^\circ$).
2. Side elevation
The filament light source placed with the cap down, the reference axis vertical and the major filament seen end-on:
 - 2.1. The projection of the major filament shall lie entirely within a rectangle of height "a" and width "b", having its centre at the theoretical position of the centre of the filament;
 - 2.2. The projection of the minor filament shall lie entirely within a rectangle of width "c" and height "d" having its centre at a distance "u" above the theoretical position of the centre of the major filament.
3. Front elevation
The filament light source being placed with the cap down and the reference axis vertical, the filament light source being viewed in a direction at right angles to axis of the major filament:
 - 3.1. The projection of the major filament shall lie entirely within a rectangle of height "a" and width "h", centred on the theoretical position of the centre of the filament;
 - 3.2. The centre of the major filament shall not be offset by more than distance "k" from the reference axis.
 - 3.3. The centre of the minor filament axis shall not be offset from the reference axis by more than ± 2 mm (± 0.4 mm for standard filament light sources).

Side elevation

Dimensions in millimeters

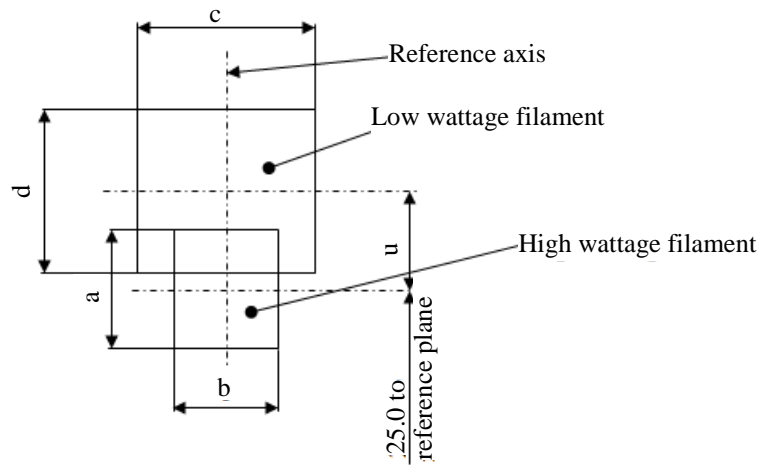

| Reference | <i>a</i> | <i>b</i> | <i>c</i> | <i>d</i> | <i>u</i> |
|------------|----------|----------|----------|----------|----------|
| Dimensions | 3.3 | 2.8 | 4.8 | | 2.8 |

Front elevation

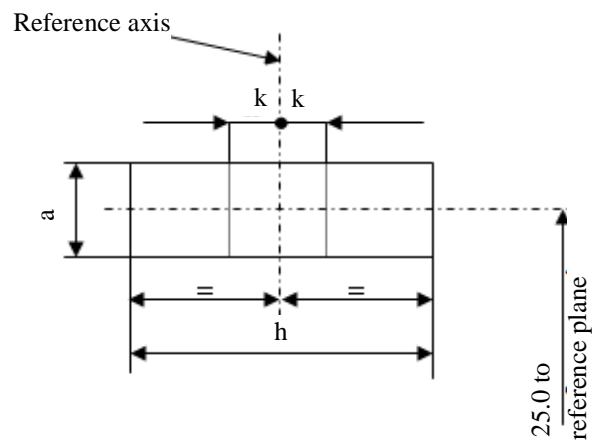

| Reference | <i>a</i> | <i>h</i> | <i>k</i> |
|------------|----------|----------|----------|
| Dimensions | 3.3 | 9.5 | 1.0 |

Categories W16W AND WY16W

Sheet W16W/1

The drawings are intended only to illustrate the essential dimensions (in mm) of the filament light source.

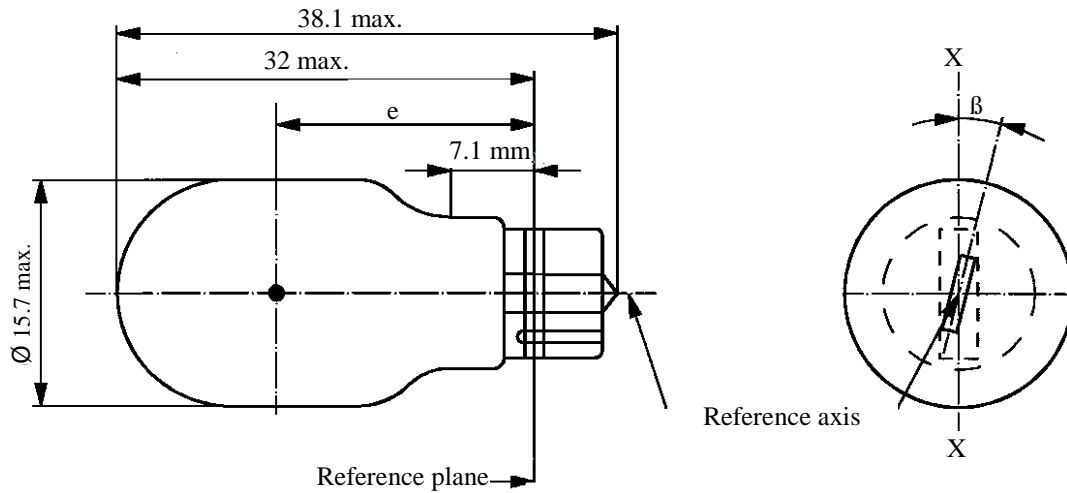

| Dimensions in mm | | Filament light sources of normal production | | | Standard filament light source |
|--|---------------|---|------------|------|--------------------------------|
| | | Min. | Nom. | Max. | |
| e | | 18.3 | 20.6 | 22.9 | 20.6 ± 0.3 |
| Lateral deviation ^{1/} | | | | 1.0 | 0.5 max. |
| β | | -15° | 0° | +15° | 0° ± 5° |
| Cap W2.1x9.5d in accordance with IEC Publication 60061 (sheet 7004-91-3) | | | | | |
| Electrical and photometric characteristics | | | | | |
| Rated values | Volts | 12 | | | 12 |
| | Watts | 16 | | | 16 |
| Test voltage | Volts | 13.5 | | | 13.5 |
| Objective values | Watts | 21.35 max. | | | 21.35 max. |
| | Luminous flux | White | 310 ± 20 % | | |
| | | Amber | 190 ± 20 % | | |
| Reference luminous flux at approximately 13.5 V: | | | | | White: 310 lm Amber: 190 lm |

^{1/} Maximum lateral deviation of filament centre from two mutually perpendicular planes both containing the reference axis and one containing axis X-X.

The drawings are intended only to illustrate the essential dimensions (in mm) of the filament light source.

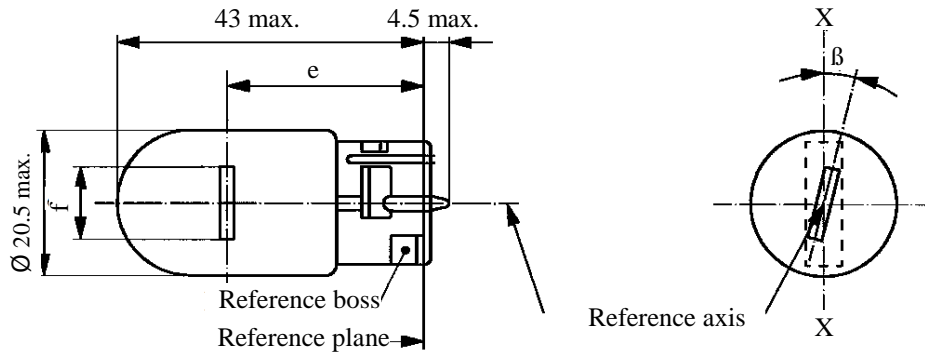

| Dimensions in mm | Filament light sources of normal production | | | Standard filament light source |
|--|---|--------------------|--------------------|--------------------------------|
| | Min. | Nom. | Max. | |
| e | | 29.0 ^{2/} | | 29.0 ± 0.3 |
| f | | | 7.5 | 7.5 + 0 / -2 |
| Lateral deviation ^{1/} | | | ^{2/} | 0.5 max. |
| β | -15° ^{2/} | 0° | +15° ^{2/} | 0° ± 5° |
| Cap W3x16d in accordance with IEC Publication 60061 (sheet 7004-105-3) | | | | |
| Electrical and photometric characteristics | | | | |
| Rated values | Volts | 12 | | 12 |
| | Watts | 21 | | 21 |
| Test voltage | Volts | 13.5 | | 13.5 |
| Objective values | Watts | 26.5 max. | | 26.5 max. |
| | Luminous flux | 460 ± 15 % | | |
| Reference luminous flux: 460 lm at approximately 13.5 V | | | | |

^{1/} Maximum lateral deviation of filament centre from two mutually perpendicular planes both containing the reference axis and one containing axis X-X.

^{2/} To be checked by means of a "Box system"; see sheet W21W/2.

Category W21W

Sheet W21W/2

Screen projection requirements

This test is used to determine, by checking whether the filament is correctly positioned relative to the reference axis and reference plane and has an axis perpendicular, within $\pm 15^\circ$, to the plane through the axis X-X and the reference axis, whether a filament light source complies with the requirements.

Side elevation

Front elevation

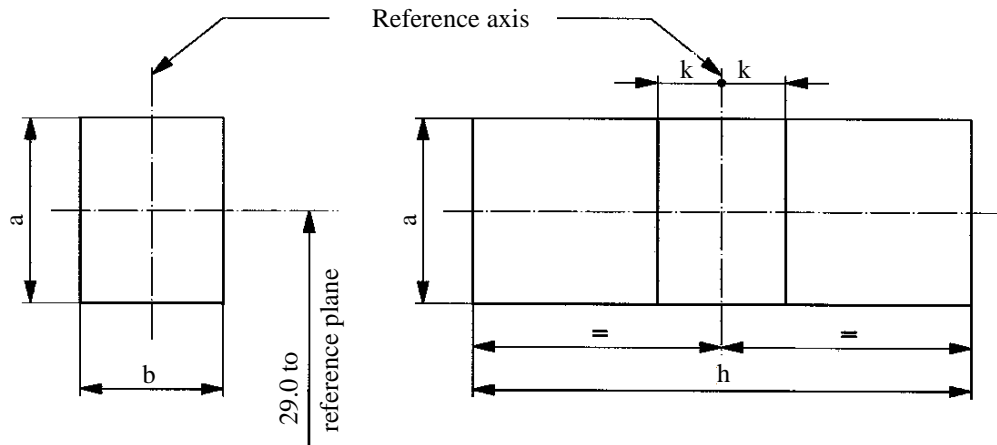

| Reference | <i>a</i> | <i>b</i> | <i>h</i> | <i>k</i> |
|-----------|----------|----------|----------|----------|
| Dimension | 3.5 | 3.0 | 9.5 | 1.0 |

Test procedures and requirements

1. The filament light source is placed in a holder capable of being rotated about its axis and having either a calibrated scale or fixed stops corresponding to the angular displacement tolerance limits, i.e. $\pm 15^\circ$. The holder is then so rotated that an end view of the filament is seen on the screen on to which the image of the filament is projected. The end view of the filament shall be obtained within the angular displacements tolerance limits ($\pm 15^\circ$).
2. Side elevation
The filament light source placed with the cap down, the reference axis vertical and the filament seen end-on, the projection of the filament shall lie entirely within a rectangle of height "a" and width "b", having its centre at the theoretical position of the centre of the filament.
3. Front elevation
The filament light source placed with the cap down and the reference axis vertical, the filament light source being viewed in a direction at right angles to the filament axis:
 - 3.1. The projection of the filament shall lie entirely within a rectangle of height "a" and width "h", having its centre at the theoretical position of the centre of the filament;
 - 3.2. The centre of the filament shall not be offset by more than distance "k" from the reference axis.

The drawings are intended only to illustrate the essential dimensions (in mm) of the filament light source.

a = major (high wattage) filament

b = minor (low wattage) filament

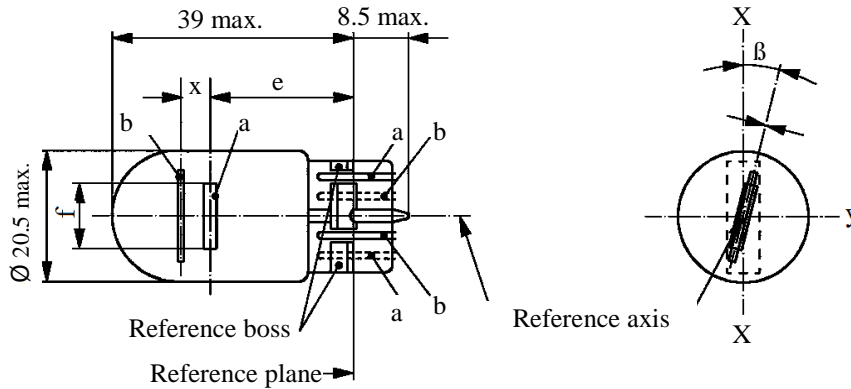

| Dimensions in mm | Filament light sources of normal production | | | Standard filament light source | |
|--|---|--------------------|--------------------|--------------------------------|----------|
| | Min. | Nom. | Max. | | |
| e | | 25.0 ^{1/} | | 25.0 ± 0.3 | |
| f | | | 7.5 | 7.5 + 0 / -2 | |
| Lateral deviation ^{2/} | | | ^{1/} | 0.3 max. | |
| x ^{3/} | | 2.8 ^{1/} | | 2.8 ± 0.3 | |
| y ^{3/} | | 0.0 ^{1/} | | 0.0 ± 0.3 | |
| β | -15° ^{1/} | 0° | +15° ^{1/} | 0° ± 5° | |
| Cap W3x16q in accordance with IEC Publication 60061 (sheet 7004-106-4) | | | | | |
| Electrical and photometric characteristics | | | | | |
| Rated values | Volts | 12 | | 12 | |
| | Watts | 21 | 5 | 21 | 5 |
| Test voltage | Volts | 13.5 | | 13.5 | |
| Objective values | Watts | 26.5 max. | 6.6 max. | 26.5 max. | 6.6 max. |
| | Luminous flux | 440 ± 15 % | 35 ± 20 % | | |
| Reference luminous flux: 440 and 35 lm at approximately 13.5 V | | | | | |

^{1/} To be checked by means of a "Box system"; sheets W21/5W/2 and 3.

^{2/} Maximum lateral deviation of filament centre from two mutually perpendicular planes both containing the reference axis and one containing axis X-X.

^{3/} "x" and "y" denote the offset of the axis of the minor filament with respect to the axis of the major filament.

Screen projection requirements

This test is used to determine, by checking whether:

- (a) The major filament is correctly positioned relative to the reference axis and reference plane and has an axis perpendicular, within $\pm 15^\circ$, to the plane through the axis X-X and the reference axis; and whether:
- (b) The minor filament is correctly positioned relative to the major filament, whether a filament light source complies with the requirements.

Test procedure and requirements.

1. The filament light source is placed in a holder capable of being rotated about its axis and having either a calibrated scale or fixed stops corresponding to the angular displacement tolerance limits. The holder is then so rotated that an end view of the major filament is seen on the screen on which the image of the filament is projected. The end view of that filament shall be obtained within the angular displacement tolerance limits ($\pm 15^\circ$).
2. Side elevation
The filament light source placed with the cap down, the reference axis vertical and the major filament seen end-on:
 - 2.1. The projection of the major filament shall lie entirely within a rectangle of height "a" and width "b", having its centre at the theoretical position of the centre of the filament;
 - 2.2. The projection of the minor filament shall lie entirely within a rectangle of width "c" and height "d" having its centre at a distance "u" above the theoretical position of the centre of the major filament.
3. Front elevation
The filament light source being placed with the cap down and the reference axis vertical, the filament light source being viewed in a direction at right angles to axis of the major filament:
 - 3.1. The projection of the major filament shall lie entirely within a rectangle of height "a" and width "h", centred on the theoretical position of the centre of the filament;
 - 3.2. The centre of the major filament shall not be offset by more than distance "k" from the reference axis;
 - 3.3. The centre of the minor filament axis shall not be offset from the reference axis by more than ± 2 mm (± 0.4 mm for standard filament light sources).

Side elevation

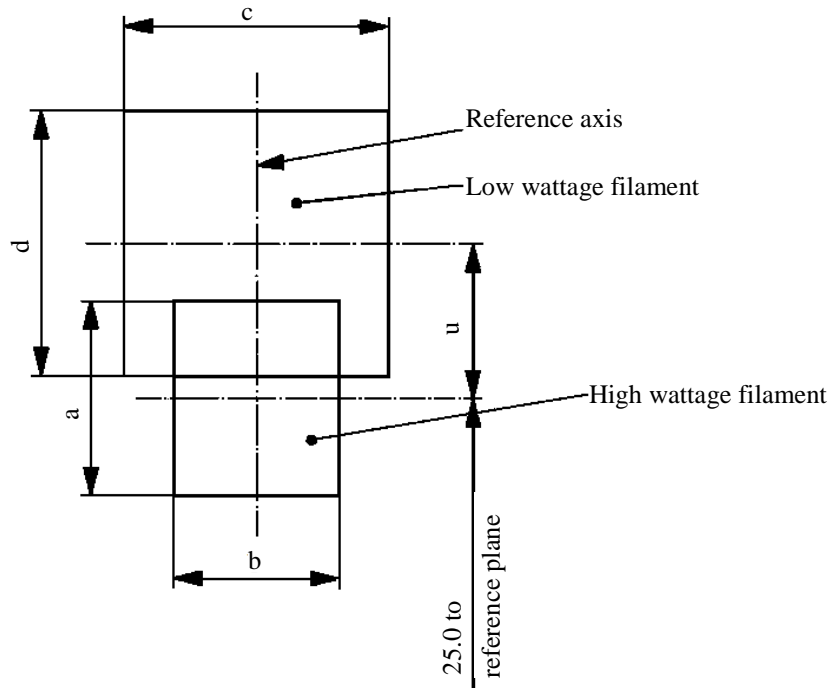

| Reference | <i>a</i> | <i>b</i> | <i>c</i> | <i>d</i> | <i>u</i> |
|-----------|----------|----------|----------|----------|----------|
| Dimension | 3.5 | 3.0 | 4.8 | | 2.8 |

Front elevation

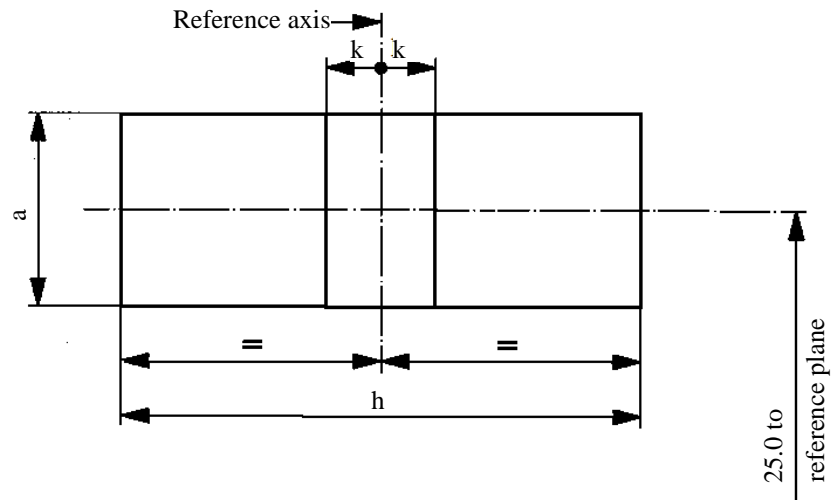

| Reference | <i>a</i> | <i>h</i> | <i>k</i> |
|-----------|----------|----------|----------|
| Dimension | 3.5 | 9.5 | 1.0 |

Categories WP21W and WPY21W

Sheet WP21W/1

The drawings are intended only to illustrate the essential dimensions (in mm) of the filament light source.

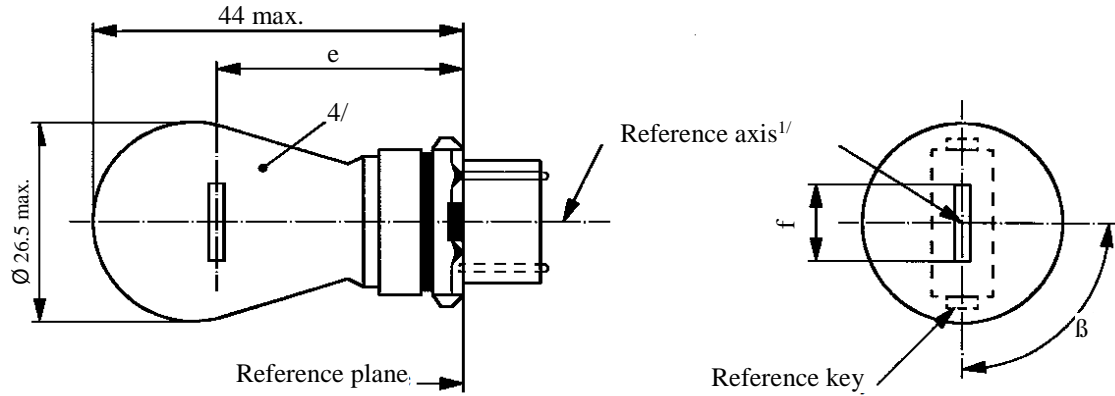

| Dimensions in mm | Filament light sources of normal production | | | Standard filament light source |
|---|---|--------------------|--------------------|---|
| | Min. | Nom. | Max. | |
| e | | 27.9 ^{3/} | | 27.9 ± 0.3 |
| f | 5.5 | 6.0 | 7.0 | 6.0 ± 0.5 |
| Lateral deviation ^{2/} | | | ^{3/} | 0.0 ± 0.4 |
| β | 75° ^{3/} | 90° | 105° ^{3/} | 90° ± 5° |
| Cap: | WP21W: WY2.5x16d WPY21W: WZ2.5x16d | | | in accordance with IEC Publication 60061 (sheet 7004-104B-1) (sheet 7004-104C-1) |
| Electrical and photometric characteristics | | | | |
| Rated values | Volts | 12 | | 12 |
| | Watts | 21 | | 21 |
| Test voltage | Volts | 13.5 | | 13.5 |
| Objective values | | Watts | 26.5 max. | |
| | Luminous flux | WP21W | 460 ± 15 % | |
| | | WPY21W | 280 ± 20 % | |
| Reference luminous flux at approximately 13.5 V | | | | White: 460 lm Amber: 280 lm |

^{1/} The reference axis is defined with respect to the reference keys and is perpendicular to the reference plane.
^{2/} Maximum lateral deviation of filament centre from two mutually perpendicular planes both containing the reference axis and one containing the axis through the reference keys.
^{3/} To be checked by means of a "Box system"; sheet WP21W/2.
^{4/} The light emitted from filament light sources of normal production shall be white for category WP21W and amber for category WPY21W (see also footnote 5/).
^{5/} The light emitted from standard filament light sources shall be white for category WP21W and white or amber for category WPY21W.

Screen projection requirements

This test is used to determine, by checking whether the filament is correctly positioned relative to the reference axis and reference plane and has an axis perpendicular, within $\pm 15^\circ$, to the plane through the centre line of the keys and the reference axis, whether a filament light source complies with the requirements.

Side elevation

Front elevation

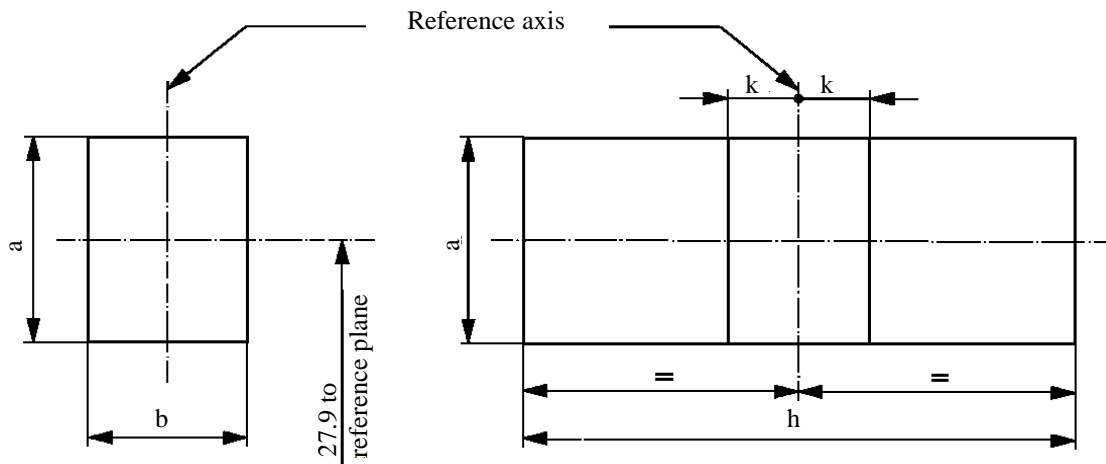

| Reference | <i>a</i> | <i>b</i> | <i>h</i> | <i>k</i> |
|-----------|----------|----------|----------|----------|
| Dimension | 3.5 | 3.0 | 9.0 | 1.0 |

Test procedures and requirements

1. The filament light source is placed in a holder capable of being rotated about its axis and having either a calibrated scale or fixed stops corresponding to the angular displacement tolerance limits. The holder is then so rotated that an end view of the filament is seen on the screen on to which the image of the filament is projected. The end view of the filament shall be obtained within the angular displacements tolerance limits.
2. Side elevation
The filament light source placed with the cap down, the reference axis vertical and the filament seen end-on, the projection of the filament shall lie entirely within a rectangle of height "a" and width "b", having its centre at the theoretical position of the centre of the filament.
3. Front elevation
The filament light source placed with the cap down and the reference axis vertical, the filament light source being viewed in a direction at right angles to the filament axis:
 - 3.1. The projection of the filament shall lie entirely within a rectangle of height "a" and width "h", having its centre at the theoretical position of the centre of the filament.
 - 3.2. The centre of the filament shall not be offset by more than distance "k" from the reference axis.

Category WR21/5W

Sheet WR21/5W/1

The drawings are intended only to illustrate the essential dimensions (in mm) of the filament light source.

a = major (high wattage) filament

b = minor (low wattage) filament

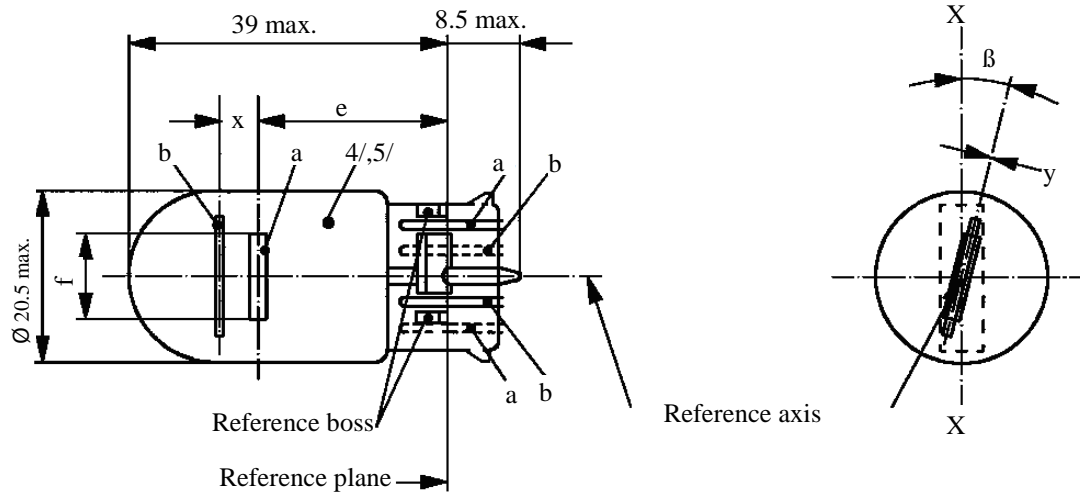

| Dimensions in mm | Filament light sources of normal production | | | Standard filament light source |
|---|---|--------------------|-------------------|--------------------------------|
| | Min. | Nom. | Max. | |
| e | | 25.0 ^{1/} | | 25.0 ± 0.3 |
| f | | | 7.5 | 7.5 + 0 / -2 |
| Lateral deviation ^{2/} | | | ^{1/} | 0.3 max. |
| x ^{3/} | | 2.8 ^{1/} | | 2.8 ± 0.3 |
| y ^{3/} | | 0.0 ^{1/} | | 0.0 ± 0.3 |
| β | -15° ^{1/} | 0° | 15° ^{1/} | 0° ± 5° |
| Cap WY3x16q in accordance with IEC Publication 60061 (sheet 7004-106-4) | | | | |
| Electrical and photometric characteristics | | | | |
| Rated values | Volts | 12 | | 12 |
| | Watts | 21 | 5 | 21 5 |
| Test voltage | Volts | 13.5 | | 13.5 |
| Objective values | Watts | 26.5 max. | 6.6 max. | 26.5 max. 6.6 max. |
| | Luminous flux | 105 ± 20 % | 8 ± 25 % | |
| Reference luminous flux at approximately 13.5 V: | | White: | 440 lm and 35 lm | |
| | | Red: | 105 lm and 8 lm | |

^{1/} To be checked by means of a "Box system"; sheets W21/5W/2 and 3.

^{2/} Maximum lateral deviation of filament centre from two mutually perpendicular planes both containing the reference axis and one containing axis X-X.

^{3/} "x" and "y" denote the offset of the axis of the minor filament with respect to the axis of the major filament.

^{4/} The light emitted from normal production filament light sources shall be red (see also footnote 5/).

^{5/} The light emitted from standard filament light sources shall be white or red.

The drawings are intended only to illustrate the essential dimensions (in mm) of the filament light source.

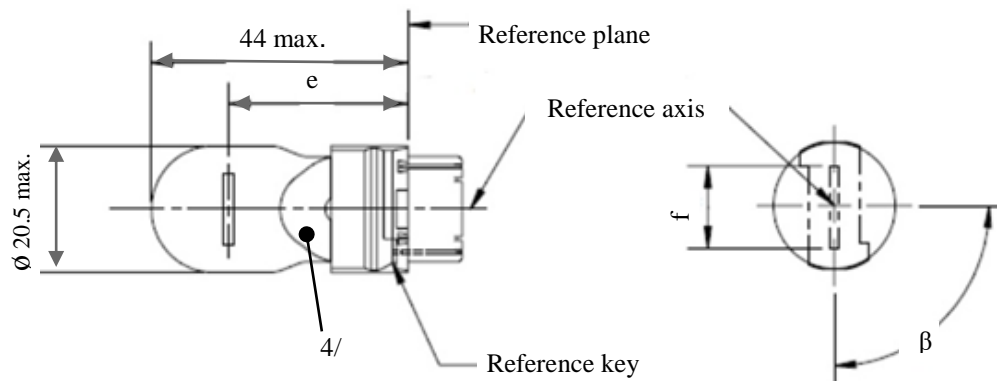

| Dimensions in mm | | Filament light sources of normal production | | | Standard filament light source ^{5/} |
|--|---------------|---|--------------------|--------------------|--|
| | | Min. | Nom. | Max. | |
| e | 12 V | | 27.9 ^{3/} | | 27.9 ± 0.3 |
| | 24 V | 26.9 | 27.9 | 28.9 | |
| f | | | | 7.5 | 7.5 + 0 / - 2 |
| Lateral deviation ^{2/} | 12 V | | | ^{3/} | 0.0 ± 0.4 |
| | 24 V | | | 1.5 | |
| β | | 75° ^{3/} | 90° | 105° ^{3/} | 90° ± 5° |
| Cap: WT21W: WUX2.5x16d WTY21W: WUY2.5x16d | | in accordance with IEC Publication 60061 | | | (sheet 7004-176-1) (sheet 7004-177-1) |
| Electrical and photometric characteristics | | | | | |
| Rated values | Volts | 12 | 24 | 12 | |
| | Watts | 21 | | | 21 |
| Test voltage | Volts | 13.5 | 28.0 | 13.5 | |
| Objective values | Watts | 26.5 max. | 29.7 max. | 26.5 max. | |
| | Luminous flux | WT21W | 460 ± 15 % | | |
| | | WTY21W | 280 ± 20 % | | |
| Reference luminous flux at approximately 13.5 V: | | | | | White: 460 lm Amber: 280 lm |

^{1/} The reference axis is defined with respect to the reference keys and is perpendicular to the reference plane.

^{2/} Maximum lateral deviation of the major (high wattage) filament centre from two mutually perpendicular planes both containing the reference axis and one containing the axis through the reference keys.

^{3/} To be checked by means of a "Box system", sheets WT21W/2.

^{4/} The light emitted from filament light sources of normal production shall be white for category WT21W and amber for category WTY21W (see also note 5/).

^{5/} The light emitted from standard filament light sources shall be white for category WT21W and white or amber for category WTY21W.

Screen projection requirements

This test is used to determine, by checking whether the filament is correctly positioned relative to the reference axis and reference plane and has an axis perpendicular, within $\pm 15^\circ$, to the plane through the centres of the keys and the reference axis, whether a filament light source complies with the requirements.

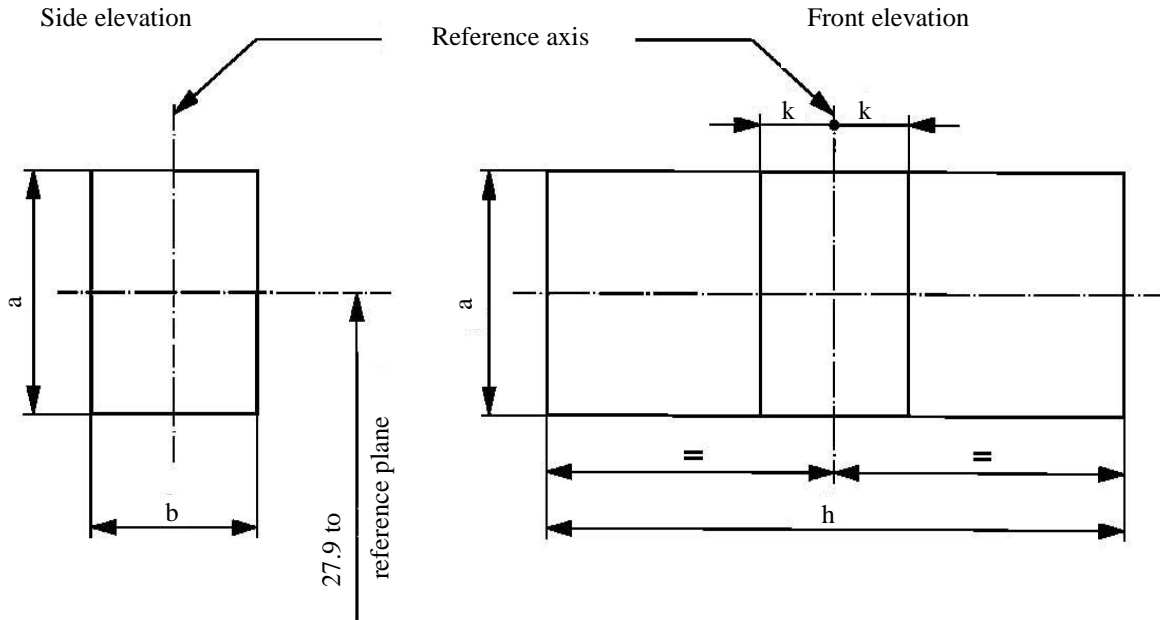

| Reference | <i>a</i> | <i>b</i> | <i>h</i> | <i>k</i> |
|-----------|----------|----------|----------|----------|
| Dimension | 3.5 | 3.0 | 9.5 | 1.0 |

Test procedures and requirements

1. The filament light source is placed in a holder capable of being rotated about its axis and having either a calibrated scale or fixed stops corresponding to the angular displacement tolerance limits. The holder is then so rotated that an end view of the filament is seen on the screen on to which the image of the filament is projected. The end view of the filament shall be obtained within the angular displacements tolerance limits.
2. Side elevation
The filament light source placed with the cap down, the reference axis vertical and the filament seen end-on, the projection of the filament shall lie entirely within a rectangle of height "a" and width "b", having its centre at the theoretical position of the centre of the filament.
3. Front elevation
The filament light source placed with the cap down and the reference axis vertical, the filament light source being viewed in a direction at right angles to the filament axis:
 - 3.1. The projection of the filament shall lie entirely within a rectangle of height "a" and width "h", having its centre at the theoretical position of the centre of the filament.
 - 3.2. The centre of the filament shall not be offset by more than distance "k" from the reference axis.

The drawings are intended only to illustrate the essential dimensions (in mm) of the filament light source.

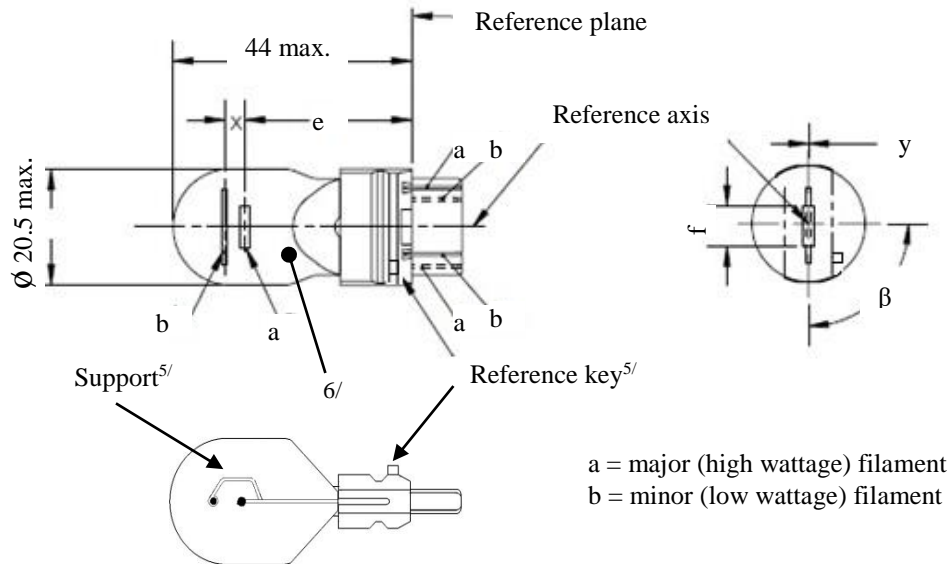

| Dimensions in mm | Filament light sources of normal production ^{6/} | | | Standard filament light source ^{7/} | |
|--|---|--------------------|--|---|----------|
| | Min. | Nom. | Max. | | |
| e | | 27.9 ^{3/} | | 27.9 ± 0.3 | |
| f | | | 7.5 | 7.5 + 0 / - 2 | |
| Lateral deviation ^{2/} | | | ^{3/} | 0.0 ± 0.4 | |
| x ^{4/} | | 5.1 ^{3/} | | 5.1 ± 0.5 | |
| y ^{4/} | | 0.0 ^{3/} | | 0.0 ± 0.5 | |
| β | 75° ^{3/} | 90° | 105° ^{3/} | 90° ± 5° | |
| Cap: | WT21/7W: WZX2.5x16q WTY21/7W: WZY2.5x16q | | | in accordance with IEC Publication 60061 (sheet 7004-180-1) (sheet 7004-181-1) | |
| Electrical and photometric characteristics | | | | | |
| Rated values | Volts | 12 | | 12 | |
| | Watts | 21 | 7 | 21 | 7 |
| Test voltage | Volts | 13.5 | | 13.5 | |
| Objective values | Watts | 26.5 max. | 8.5 max. | 26.5 max. | 8.5 max. |
| | Luminous flux | 440 ± 15 % | 35 ± 20 % | | |
| 280 ± 20 % | | 22 ± 20 % | | | |
| Reference luminous flux at approximately 13.5 V: | | | White: 440 and 35 lm Amber: 280 and 22 lm | | |

For the notes see sheet WT21/7W/2.

Categories WT21/7W and WTY21/7W

Sheet WT21/7W/2

- ^{1/} The reference axis is defined with respect to the reference keys and is perpendicular to the reference plane.
- ^{2/} Maximum lateral deviation of the major (high wattage) filament centre from two mutually perpendicular planes both containing the reference axis and one containing the axis through the reference keys.
- ^{3/} To be checked by means of a "Box system", sheets WT21/7W/2 and 3.
- ^{4/} "x" and "y" denote the offset of the axis of the minor (low wattage) filament with respect to the axis of the major (high wattage) filament.
- ^{5/} If the minor filament is positioned using an asymmetric support similar to the one shown then the reference key and support structure shall be located on the same side of the filament light source.
- ^{6/} The light emitted from filament light sources of normal production shall be white for category WT21/7W and amber for category WTY21/7W (see also note 7/).
- ^{7/} The light emitted from standard filament light sources shall be white for category WT21/7W and white or amber for category WTY21/7W.

Screen projection requirements

This test is used to determine, by checking whether:

- (a) The major (high wattage) filament is correctly positioned relative to the reference axis and reference plane and has an axis perpendicular, within $\pm 15^\circ$, to the plane through the centres of the keys and the reference axis; and whether:
- (b) The minor (low wattage) filament is correctly positioned relative to the major (high wattage) filament, whether a filament light source complies with the requirements.

Test procedure and requirements.

1. The filament light source is placed in a holder capable of being rotated about its axis and having either a calibrated scale or fixed stops corresponding to the angular displacement tolerance limits. The holder is then so rotated that an end view of the major filament is seen on the screen on which the image of the filament is projected. The end view of that filament shall be obtained within the angular displacement tolerance limits.
2. Side elevation

The filament light source placed with the cap down, the reference axis vertical, the reference key to the right and the major filament seen end-on:

 - 2.1. The projection of the major filament shall lie entirely within a rectangle of height "a" and width "b", having its centre at the theoretical position of the centre of the filament;
 - 2.2. The projection of the minor filament shall lie entirely within a rectangle of width "c" and height "d" having its centre at a distance "u" above the theoretical position of the centre of the major filament.
3. Front elevation

The filament light source being placed with the cap down and the reference axis vertical, the filament light source being viewed in a direction at right angles to axis of the major filament:

 - 3.1. The projection of the major filament shall lie entirely within a rectangle of height "a" and width "h", centred on the theoretical position of the centre of the filament;
 - 3.2. The centre of the major filament shall not be offset by more than distance "k" from the reference axis;
 - 3.3. The centre of the minor filament axis shall not be offset from the reference axis by more than ± 2 mm (± 0.4 mm for standard filament light sources).

Side elevation

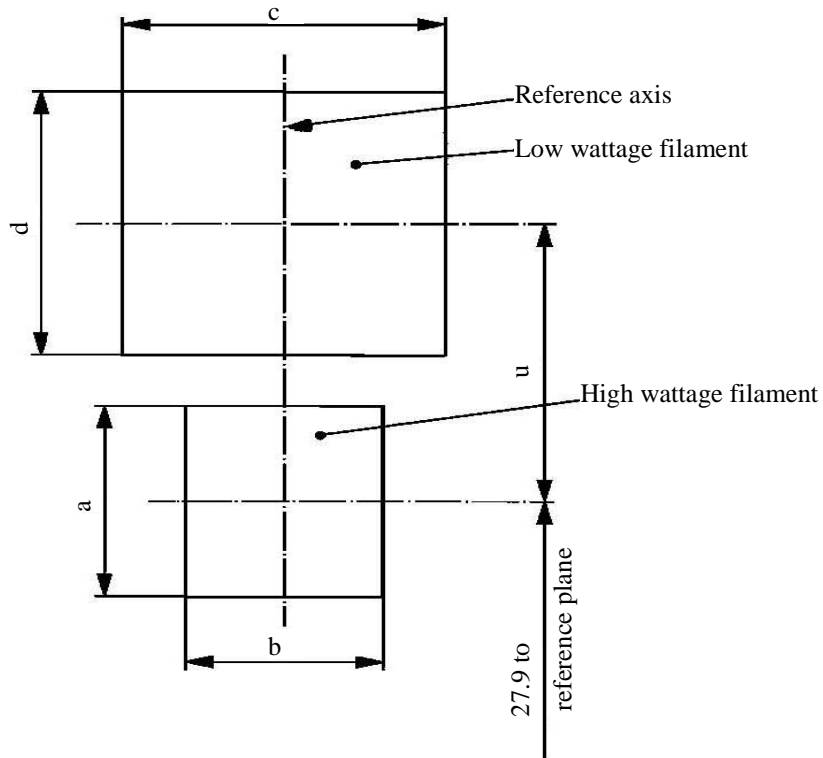

| Reference | a | b | c | d | u |
|------------|-----|-----|-----|-----|-----|
| Dimensions | 3.5 | 3.0 | 4.8 | | 5.1 |

Front elevation

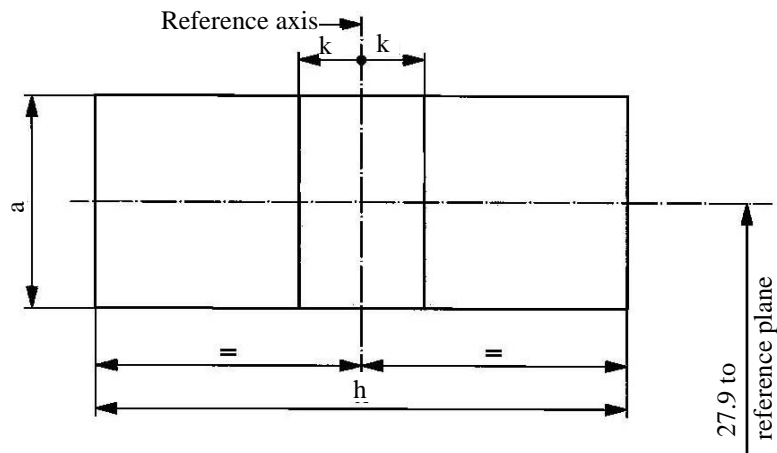

| Reference | a | h | k |
|------------|-----|-----|-----|
| Dimensions | 3.5 | 9.5 | 1.0 |

The drawings are intended only to illustrate the essential dimensions (in mm) of the filament light source.

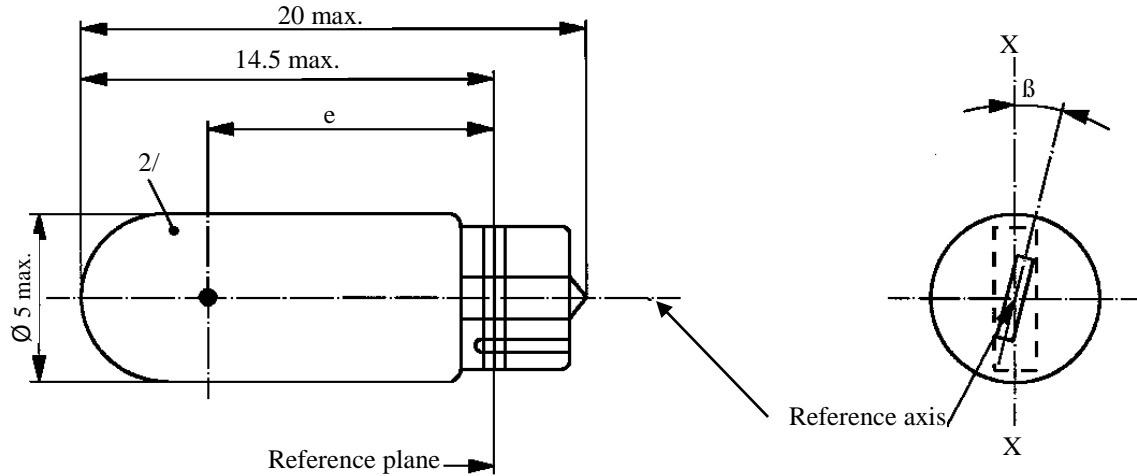

| Dimensions in mm | | Filament light sources of normal production | | | Standard filament light source |
|--|---------------|---|------|------|----------------------------------|
| | | Min. | Nom. | Max. | |
| e | | 10.3 | 10.8 | 11.3 | 10.8 ± 0.3 |
| Lateral deviation ^{1/} | | | | 1.0 | 0.5 max. |
| β | | -15° | 0° | +15° | $0^\circ \pm 5^\circ$ |
| Cap W2x4.6d in accordance with IEC Publication 60061 (sheet 7004-94-2) | | | | | |
| Electrical and photometric characteristics | | | | | |
| Rated values | Volts | 12 | | | 12 |
| | Watts | 2.3 | | | 2.3 |
| Test voltage | Volts | 13.5 | | | 13.5 |
| Objective values | Watts | 2.5 max. | | | 2.5 max. |
| | Luminous flux | $11.2 \pm 20 \%$ | | | |
| Reference luminous flux at approximately 13.5 V | | | | | White: 18.6 lm Amber: 11.2 lm |

^{1/} Maximum lateral deviation of filament centre from two mutually perpendicular planes both containing the reference axis and one containing axis X-X.

^{2/} The light emitted from production filament light sources shall be amber (see also footnote 3/).

^{3/} The light emitted from standard filament light sources shall be amber or white.

The drawings are intended only to illustrate the essential dimensions (in mm) of the filament light source.

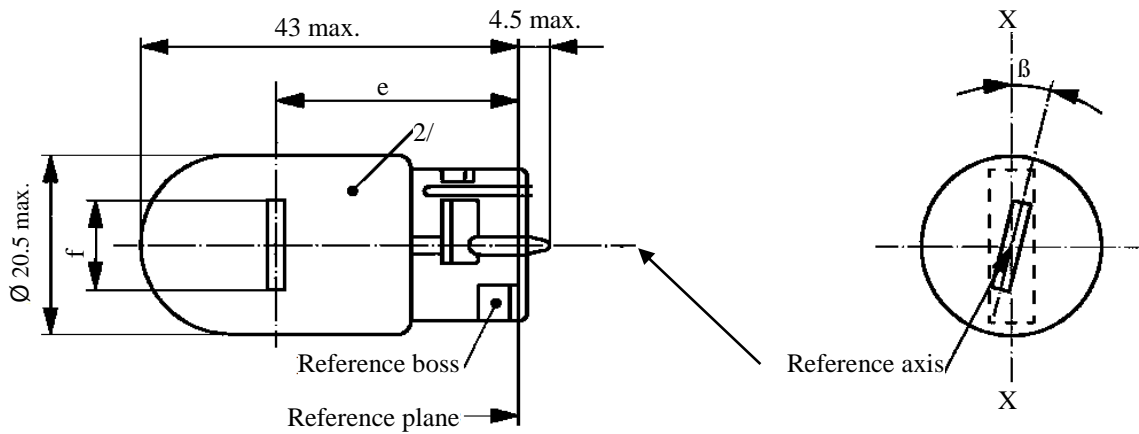

| Dimensions in mm | Filament light sources of normal production | | | Standard filament light source |
|---|---|--------------------|---------------|--------------------------------|
| | Min. | Nom. | Max. | |
| e | | 29.0 ^{2/} | | 29.0 ± 0.3 |
| f | | | 7.5 | 7.5 + 0 / -2 |
| Lateral deviation ^{1/} | | | ^{2/} | 0.5 max. |
| β | -15° | 0° | +15° | 0° ± 5° |
| Cap WX3x16d in accordance with IEC Publication 60061 (sheet 7004-105-3) | | | | |
| Electrical and photometric characteristics | | | | |
| Rated values | Volts | 12 | | 12 |
| | Watts | 21 | | 21 |
| Test voltage | Volts | 13.5 | | 13.5 |
| Objective values | Watts | 26.5 max. | | 26.5 max. |
| | Luminous flux | 280 ± 20 % | | |
| Reference luminous flux at approximately 13.5 V: | | | | White: 460 lm Amber: 280 lm |

^{1/} Maximum lateral deviation of filament centre from two mutually perpendicular planes both containing the reference axis and one containing axis X-X.

^{2/} The light emitted from filament light sources of normal production shall be amber (see also footnote 4/).

^{3/} To be checked by means of a "Box system"; sheet WY21W/2.

^{4/} The light emitted from standard filament light sources shall be amber or white.

Screen projection requirements

This test is used to determine, by checking whether the filament is correctly positioned relative to the reference axis and reference plane and has an axis perpendicular, within $\pm 15^\circ$, to the plane through the axis X-X and the reference axis, whether a filament light source complies with the requirements.

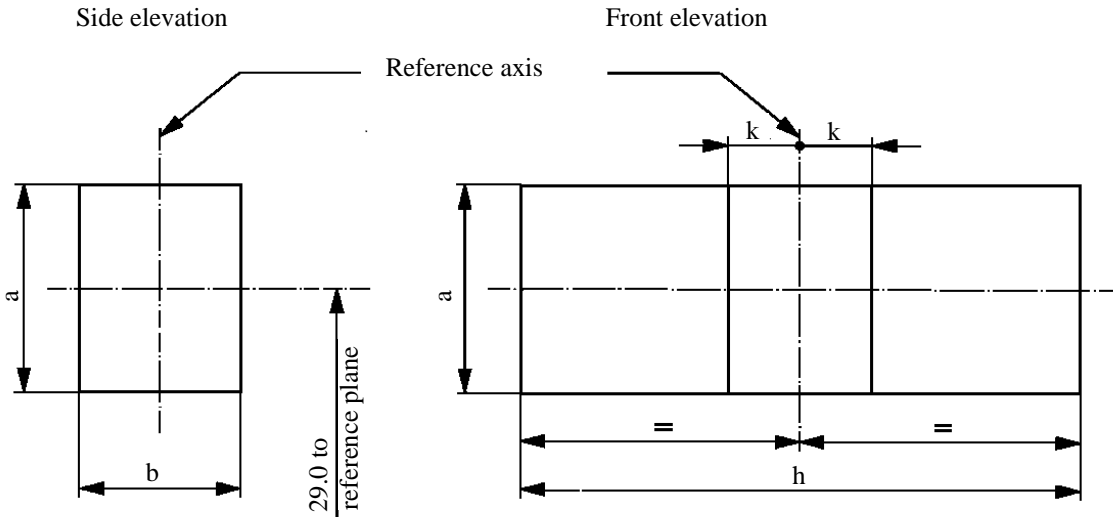

| Reference | a | b | h | k |
|-----------|-----|-----|-----|-----|
| Dimension | 3.5 | 3.0 | 9.5 | 1.0 |

Test procedures and requirements

1. The filament light source is placed in a holder capable of being rotated about its axis and having either a calibrated scale or fixed stops corresponding to the angular displacement tolerance limits, i.e. $\pm 15^\circ$. The holder is then so rotated that an end view of the filament is seen on the screen on to which the image of the filament is projected. The end view of the filament shall be obtained within the angular displacements tolerance limits ($\pm 15^\circ$).
2. Side elevation
The filament light source placed with the cap down, the reference axis vertical and the filament seen end-on, the projection of the filament shall lie entirely within a rectangle of height "a" and width "b", having its centre at the theoretical position of the centre of the filament.
3. Front elevation
The filament light source placed with the cap down and the reference axis vertical, the filament light source being viewed in a direction at right angles to the filament axis:
 - 3.1. The projection of the filament shall lie entirely within a rectangle of height "a" and width "h", having its centre at the theoretical position of the centre of the filament.
 - 3.2. The centre of the filament shall not be offset by more than distance "k" from the reference axis.

Annex 2

Sheets for gas-discharge light sources

List of sheets for gas-discharge light sources and their sequence in this annex:

Sheet numbers

DxR/1 to 7 (Sheet DxR/6: two pages)

DxS/1 to 6

D5S/1 to 5

D6S/1 to 5

D8R/1 to 6

D8S/1 to 5

D9S/1 to 5

The drawings are intended only to illustrate the essential dimensions (in mm) of the gas-discharge light source

Figure 1

Main drawing of category D1R - Type with cables - Cap PK32d-3

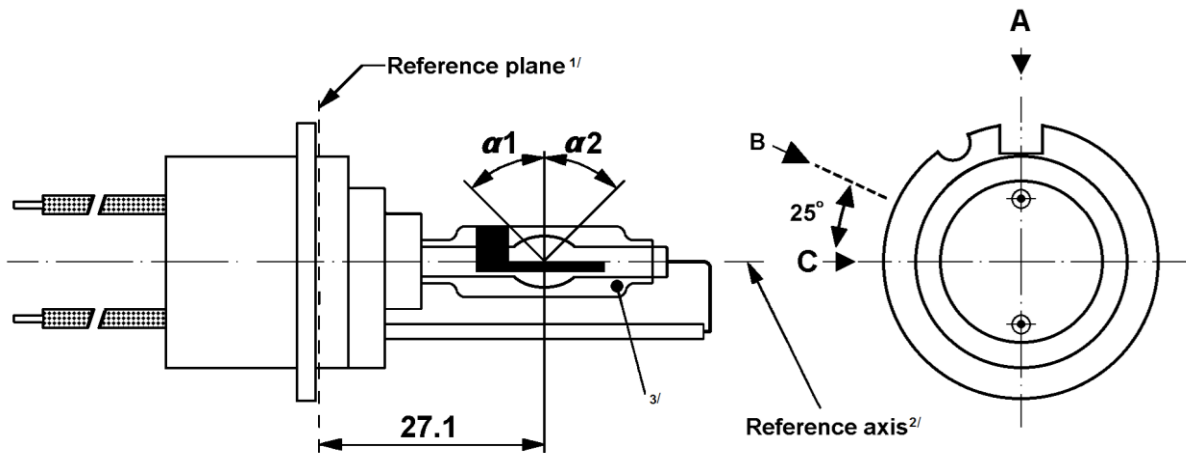
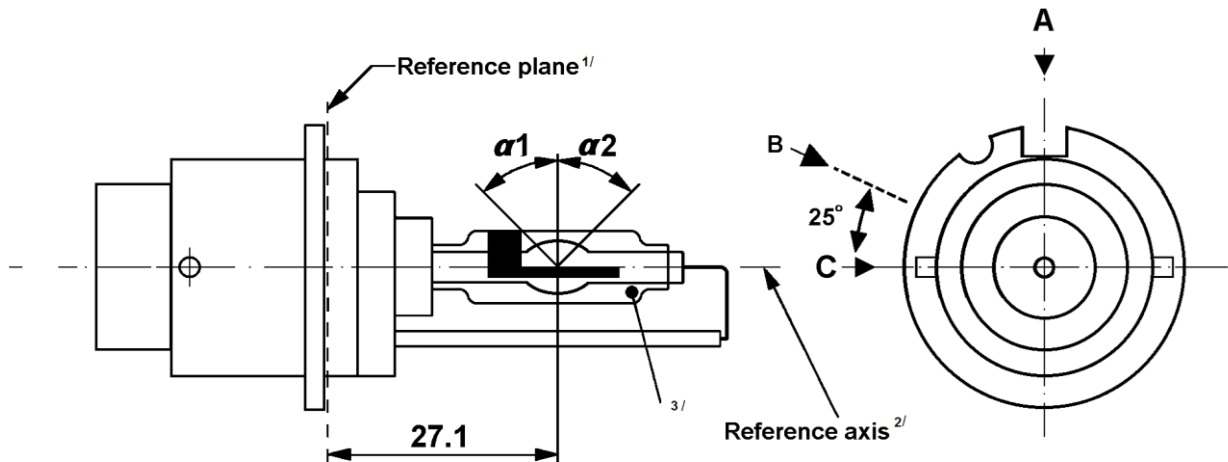

Figure 2

Main drawing of category D2R - Type with connector - Cap P32d-3



^{1/} The reference plane is defined by the positions on the surface of the holder on which the three supporting bosses of the cap ring will rest.

^{2/} See sheet DxR/3.

^{3/} With respect to the reference axis, when measured at a distance of 27.1 mm from the reference plane the eccentricity of the outer bulb shall be less than ± 0.5 mm in direction C and less than -1 mm $/+0.5$ mm in direction A.

The drawings are intended only to illustrate the essential dimensions (in mm) of the gas-discharge light source

Figure 3

Main drawing of category D3R - Type with starter – Cap PK32d-6

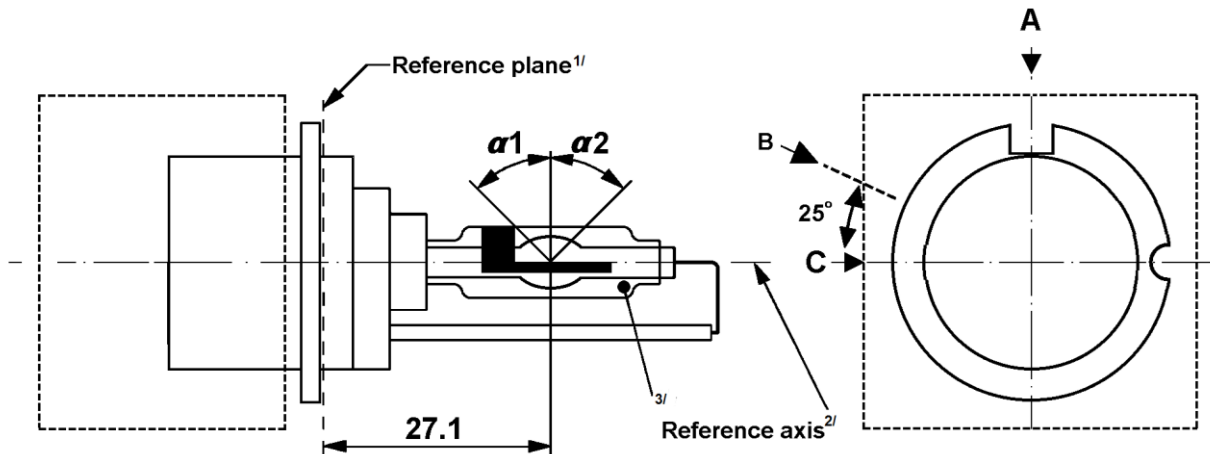
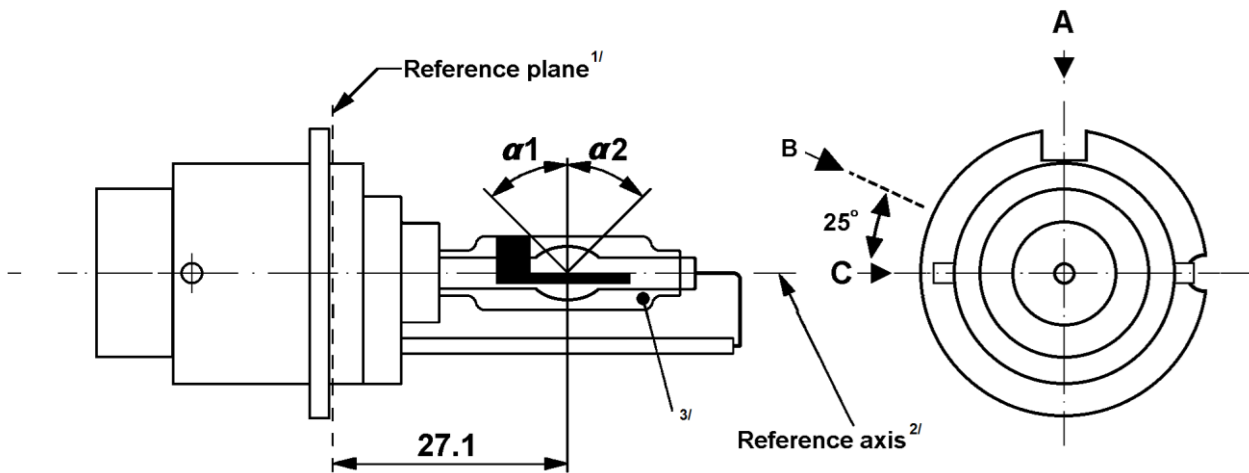

Figure 4

Main drawing of category D4R - Type with connector – Cap P32d-6



^{1/} The reference plane is defined by the positions on the surface of the holder on which the three supporting bosses of the cap ring will rest.

^{2/} See sheet DxR/3.

^{3/} With respect to the reference axis, when measured at a distance of 27.1 mm from the reference plane the eccentricity of the outer bulb shall be less than ± 0.5 mm in direction C and less than -1 mm $/+0.5$ mm in direction A.

Figure 5

Definition of reference axis^{1/}

The cap shall be pushed in this direction

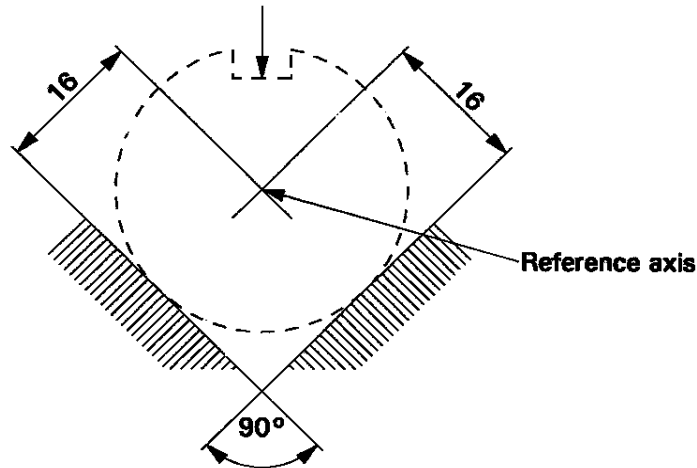
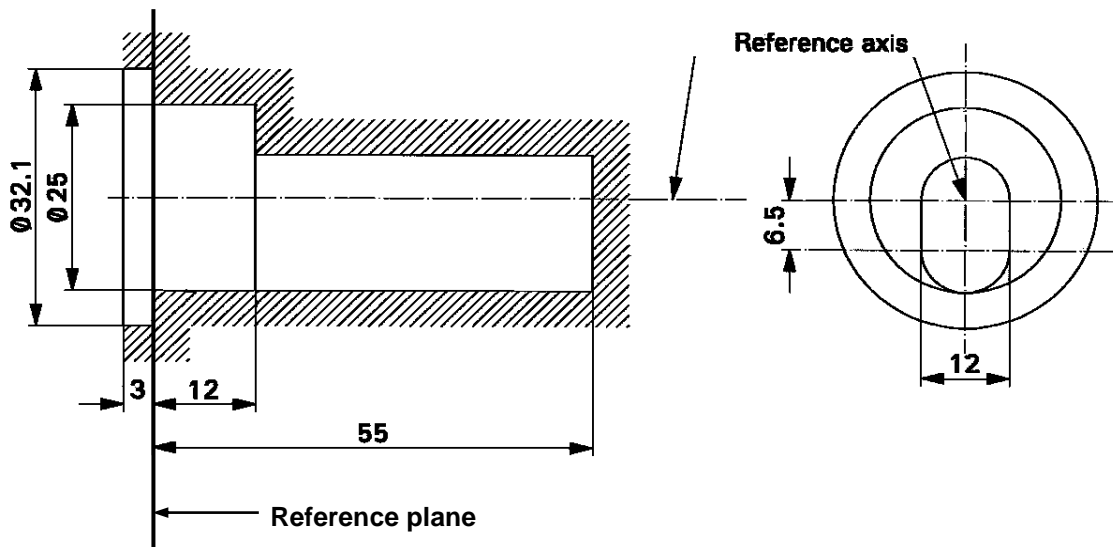

Figure 6

Maximum gas discharge light source outline^{2/}

^{1/} The reference axis is perpendicular to the reference plane and crosses the intersection of the two parallel lines as indicated in figure 5.

^{2/} Glass bulb and supports shall not exceed the envelope, as indicated in figure 6. The envelope is concentric with the reference axis.

| <i>Dimensions</i> | | <i>Production light sources</i> | <i>Standard light sources</i> | | | |
|--|---------------------|---|-------------------------------|-----------|---------------------|---------|
| Position of electrodes | | Sheet DxR/5 | | | | |
| Position and form of the arc | | Sheet DxR/6 | | | | |
| Position of the black stripes | | Sheet DxR/7 | | | | |
| $\alpha 1$ ^{1/} | | $45^\circ \pm 5^\circ$ | | | | |
| $\alpha 2$ ^{1/} | | 45° min. | | | | |
| D1R: Cap PK32d-3 D2R: Cap P32d-3 D3R: Cap PK32d-6 D4R: Cap P32d-6 | | in accordance with IEC Publication 60061 (sheet 7004-111-5) | | | | |
| ELECTRICAL AND PHOTOMETRIC CHARACTERISTICS | | | | | | |
| | | D1R/ D2R | D3R/D4R | | D1R/D2 R | D3R/D4R |
| Rated voltage of the ballast | V | 12 ^{2/} | | 12 | | |
| Rated wattage | W | 35 | | 35 | | |
| Test voltage | V | 13.5 | | 13.5 | | |
| Gas discharge light source voltage | Objective | V | 85 | 42 | 85 | 42 |
| | Tolerance | | ± 17 | ± 9 | ± 8 | ± 4 |
| Gas discharge light source wattage | Objective | W | 35 | | 35 | |
| | Tolerance | | ± 3 | | ± 0.5 | |
| Luminous flux | Objective | lm | 2800 | | 2800 | |
| | Tolerance | | ± 450 | | ± 150 | |
| Chromaticity co-ordinates in the case of white light | Objective | | x = 0.375 | | y = 0.375 | |
| | Tolerance area | Boundaries | x = 0.345 | | y = 0.150 + 0.640 x | |
| | | | x = 0.405 | | y = 0.050 + 0.750 x | |
| | | | x = 0.345 | | y = 0.371 | |
| Tolerance area | Intersection points | x = 0.405 | | y = 0.409 | | |
| | | x = 0.405 | | y = 0.354 | | |
| | | x = 0.345 | | y = 0.309 | | |
| Hot re-strike switch-off time | s | 10 | | 10 | | |

^{1/} The part of the bulb within the angles $\alpha 1$ and $\alpha 2$ shall be the light emitting part. This part shall be as homogeneous in form as possible and shall be optically distortion free. This applies to the whole bulb circumference within the angles $\alpha 1$ and $\alpha 2$ except for the black stripes.

^{2/} Application voltages of ballasts may differ from 12 V.

Categories D1R, D2R, D3R and D4R

Sheet DxR/5

Position of the electrodes

This test is used to determine whether the electrodes are correctly positioned relative to the reference axis and the reference plane.

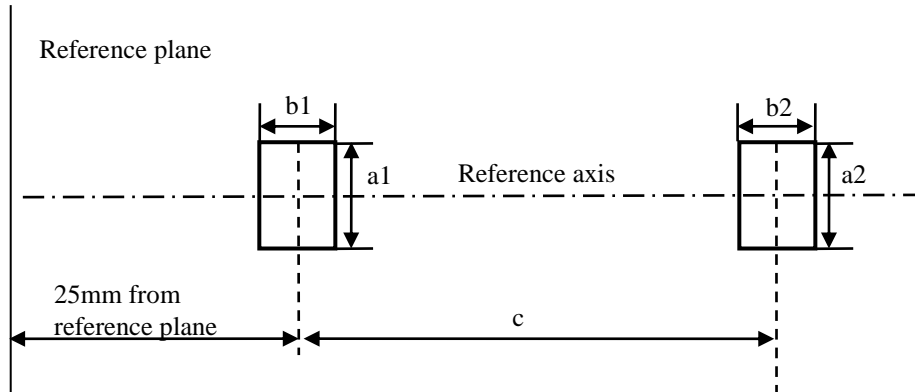

Measuring direction: light source side and top view

| <i>Dimension in mm</i> | <i>Production light sources</i> | <i>Standard light sources</i> |
|----------------------------|-------------------------------------|-----------------------------------|
| a1 | $d + 0.5$ | $d + 0.2$ |
| a2 | $d + 0.7$ | $d + 0.35$ |
| b1 | 0.4 | 0.15 |
| b2 | 0.8 | 0.3 |
| c | 4.2 | 4.2 |

d = diameter of the electrode;
 $d < 0.3$ for D1R and D2R;
 $d < 0.4$ for D3R and D4R.

The top of the electrode nearest to the reference plane shall be positioned in the area defined by $a1$ and $b1$. The top of the electrode furthest from the reference plane shall be positioned in the area defined by $a2$ and $b2$.

Position and form of the arc

This test is used to determine the form and sharpness of the arc and its position relative to the reference axis and plane by determining its bending and diffusion; by measuring the luminance in the central cross section D, where L_{maxC} is the maximum luminance of the arc measured from viewing direction C; see sheet DxR/2.

L_{maxC}

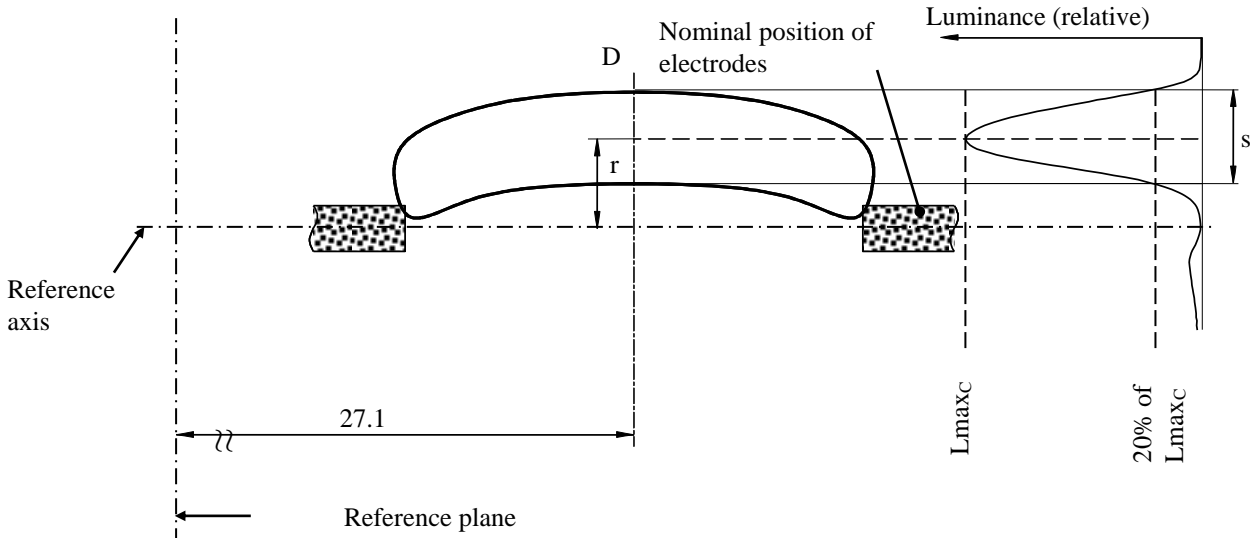

Relative luminance distribution in the central cross section D.

The form of the arc is for illustration purpose only.

Measuring direction C as defined on sheet DxR/7.

When measuring the relative luminance distribution in the central cross section D as indicated in the drawing above, the maximum value L_{maxC} has the distance r from the reference axis. The points of 20% of L_{maxC} have the distance s , as shown in the drawing above.

| Dimension in mm | Production light sources | | Standard light sources |
|-------------------|--------------------------|---------------------|------------------------|
| | D1R/D2R | D3R/D4R | |
| r (arc bending) | 0.50 ± 0.25 | 0.50 ± 0.25 | 0.50 ± 0.20 |
| s (arc diffusion) | 1.10 ± 0.25 | $1.10 + 0.25/-0.40$ | 1.10 ± 0.25 |

Stray light

This test is used to determine unwanted reflected stray light by measuring the luminance in Zone A and at lines B and C, where L_{maxB} is the maximum luminance of the arc measured from viewing direction B; see sheet DxR/2.

L_{maxB}

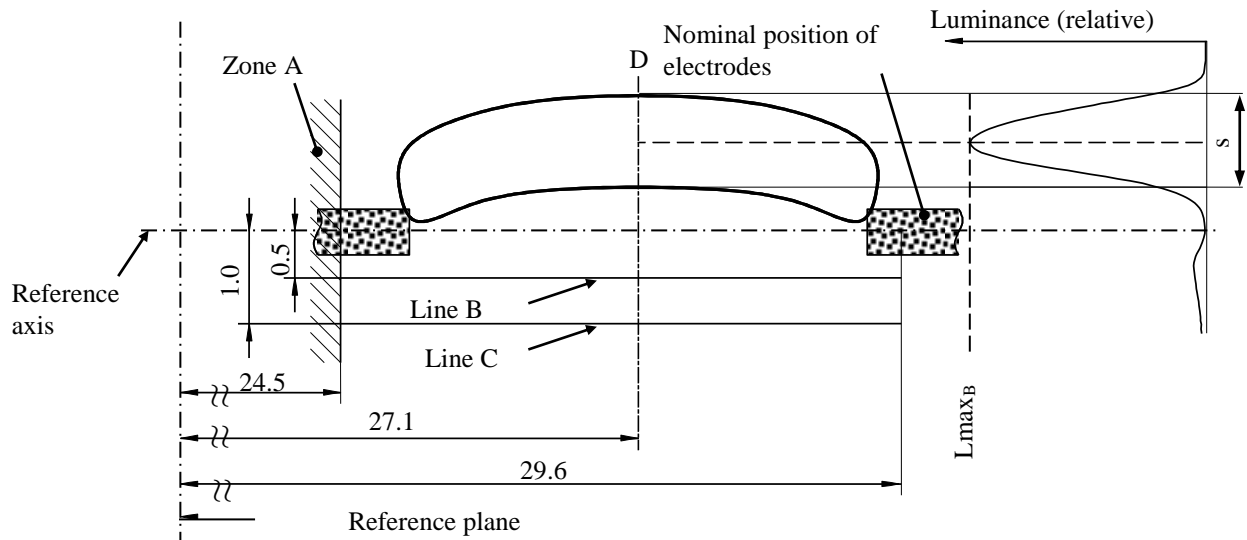

Relative luminance distribution in the central cross section D.

The form of the arc is for illustration purpose only.

Measuring direction B as defined on sheet DxR/7.

When measuring the luminances from measuring direction B as defined on sheet DxR/7, the relative luminance expressed as a percentage of L_{maxB} (at cross section D) shall be:

| | |
|--------|---------------|
| Zone A | $\leq 4.5 \%$ |
| Line B | $\leq 15 \%$ |
| Line C | $\leq 5.0 \%$ |

The area of zone A is defined by the black coating, the outer bulb and a plane at 24.5 mm from the reference plane.

Position of black stripes

This test is used to determine whether the black stripes are correctly positioned relative to the reference axis and the reference plane.

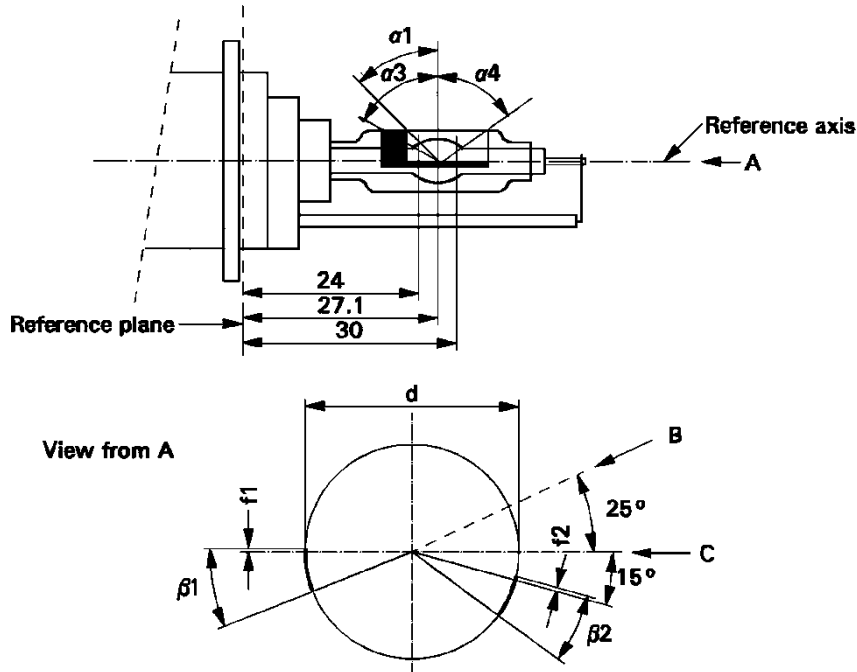

When measuring the luminance distribution of the arc in the central cross section as defined on sheet DxR/6, after having turned the light source so that the black stripe is covering the arc, the measured luminance shall be $\leq 0.5\%$ of L_{max} .

In the area defined by α_1 and α_3 the black coating may be replaced by any other means which prevents light transmission through the specified area.

| Dimensions | Production light sources | Standard light sources |
|--|--|-----------------------------|
| α_1 | $45^\circ \pm 5^\circ$ | |
| α_3 | 70° min. | |
| α_4 | 65° min. | |
| $\beta_1/24, \beta_1/30, \beta_2/24, \beta_2/30$ | $25^\circ \pm 5^\circ$ | |
| $f_1/24, f_2/24$ ^{1/} | 0.15 ± 0.25 | 0.15 ± 0.20 |
| $f_1/30$ ^{1/} | $f_1/24 \text{ mv} \pm 0.15$ ^{2/} | $f_1/24 \text{ mv} \pm 0.1$ |
| $f_2/30$ ^{1/} | $f_2/24 \text{ mv} \pm 0.15$ ^{2/} | $f_2/24 \text{ mv} \pm 0.1$ |
| $f_1/24 \text{ mv} - f_2/24 \text{ mv}$ | $\pm 0.3 \text{ max.}$ | $\pm 0.2 \text{ max.}$ |
| d | 9 ± 1 | |

^{1/} "f1/.." means dimension f1 to be measured at the distance from the reference plane indicated in mm after the stroke.

^{2/} ".../24 mv" means the value measured at a distance of 24 mm from the reference plane.

The drawings are intended only to illustrate the essential dimensions (in mm) of the gas-discharge light source

Figure 1

Main drawing of category D1S - Type with cables - Cap PK32d-2

Figure 2

Main drawing of category D2S - Type with connector - Cap P32d-2

^{1/} The reference plane is defined by the positions on the surface of the holder on which the three supporting bosses of the cap ring will rest.

^{2/} See sheet DxS/3.

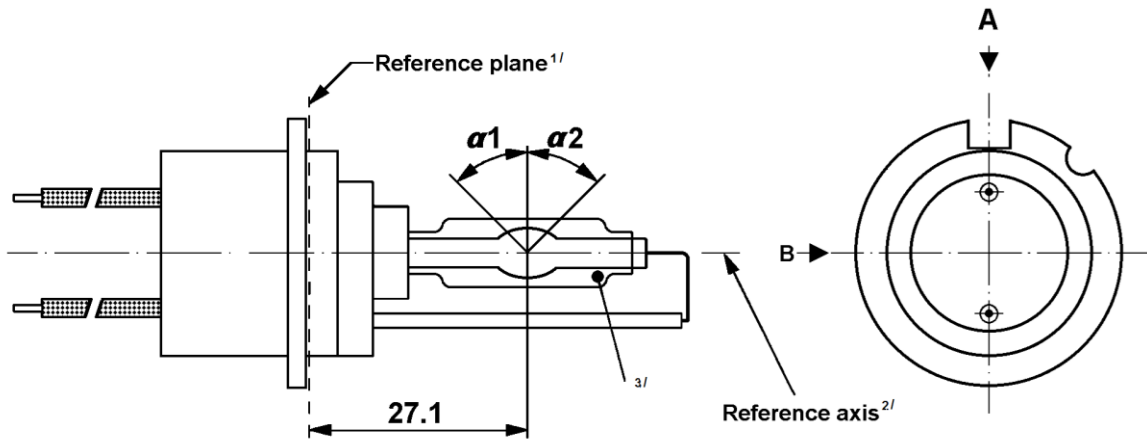
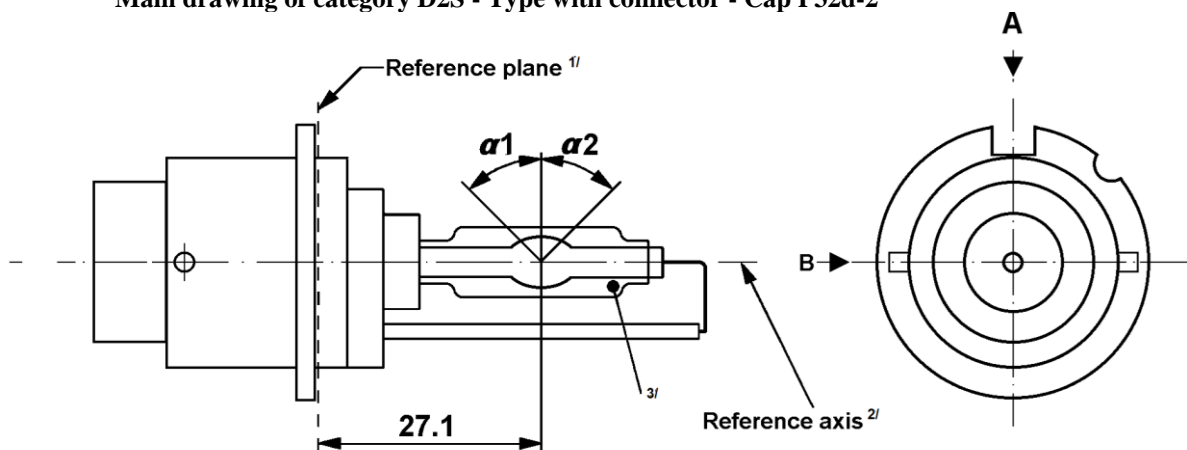
^{3/} When measured at a distance of 27.1 mm from the reference plane and with respect to the mid-point of the inner bulb, the outer bulb shall have an eccentricity of 1 mm max.

The drawings are intended only to illustrate the essential dimensions (in mm) of the gas-discharge light source

Figure 3

Main drawing of category D3S - Type with starter - Cap PK32d-5

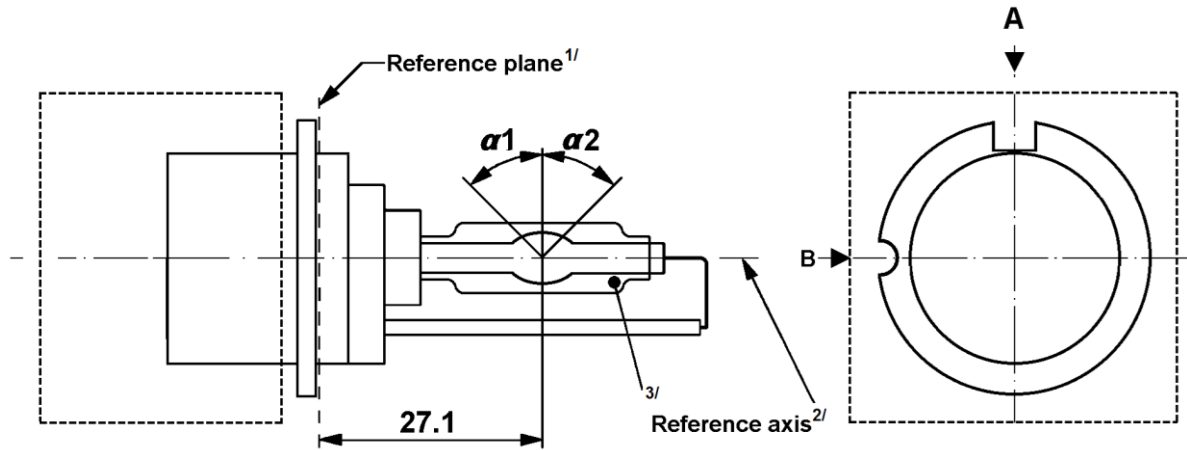
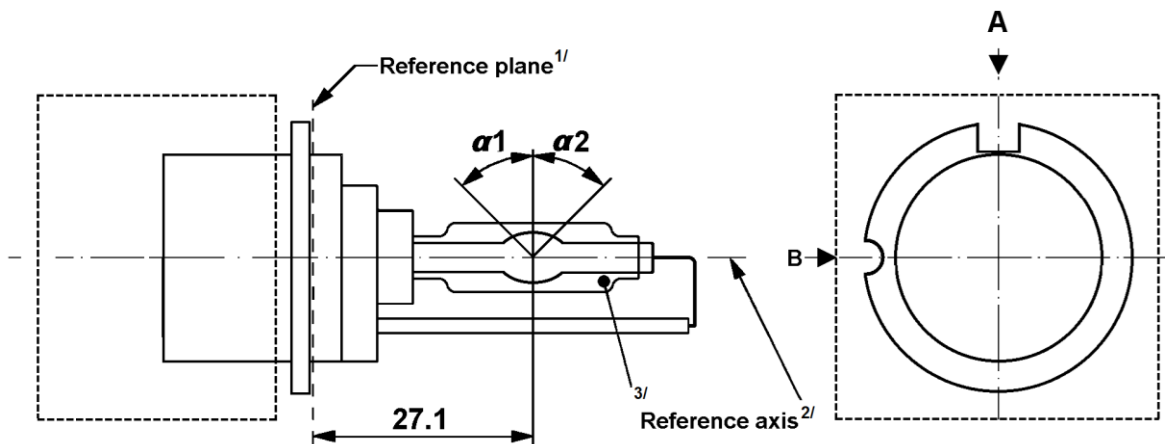

Figure 4

Main drawing of category D4S - Type with connector - Cap P32d-5



^{1/} The reference plane is defined by the positions on the surface of the holder on which the three supporting bosses of the cap ring will rest.

^{2/} See sheet DxS/3.

^{3/} When measured at a distance of 27.1 mm from the reference plane and with respect to the mid-point of the inner bulb, the outer bulb shall have an eccentricity of 1 mm max.

Figure 5

Definition of reference axis^{1/}

The cap shall be pushed in this direction

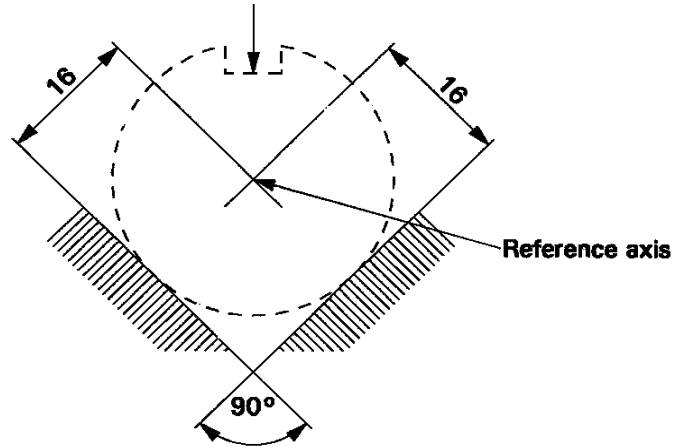
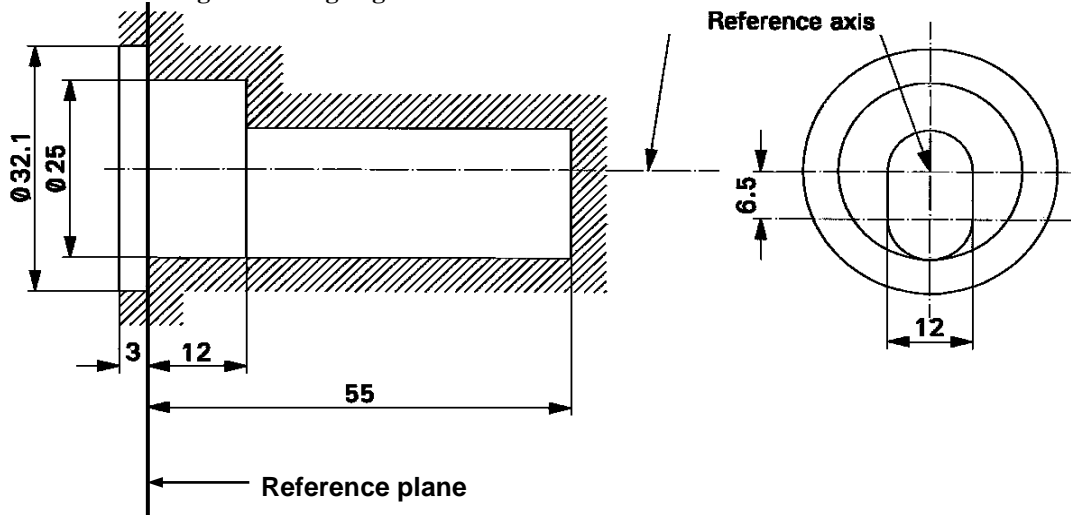

Figure 6
Maximum gas discharge light source outline^{2/}



^{1/} The reference axis is perpendicular to the reference plane and crosses the intersection of the two parallel lines as indicated in figure 5.

^{2/} Glass bulb and supports shall not exceed the envelope, as indicated in figure 6. The envelope is concentric with the reference axis.

| Dimensions | | Production light sources | Standard light sources | | | |
|--|----------------|---|---------------------------|---------|--|----|
| Position of electrodes | | Sheet DxS/5 | | | | |
| Position and form of the arc | | Sheet DxS/6 | | | | |
| $\alpha_1, \alpha_2^{1/}$ | | 55° min. | 55° min. | | | |
| D1S: Cap PK32d-2 D2S: Cap P32d-2 D3S: Cap PK32d-5 D4S: Cap P32d-5 | | in accordance with IEC Publication 60061 (sheet 7004-111-5) | | | | |
| ELECTRICAL AND PHOTOMETRIC CHARACTERISTICS | | | | | | |
| | | D1S/D2S | D3S/D4S | D1S/D2S | D3S/D4S | |
| Rated voltage of the ballast | | V | 12 ^{2/} | 12 | | |
| Rated wattage | | W | 35 | 35 | | |
| Test voltage | | V | 13.5 | 13.5 | | |
| Gas discharge light source voltage | Objective | V | 85 | 42 | 85 | 42 |
| | Tolerance | | ±17 | ±9 | ±8 | ±4 |
| Gas discharge light source wattage | Objective | W | 35 | | 35 | |
| | Tolerance | | ±3 | | ±0.5 | |
| Luminous flux | Objective | lm | 3200 | | 3200 | |
| | Tolerance | | ±450 | | ±150 | |
| Chromaticity co- ordinates in the case of white light | Objective | | x = 0.375 | | y = 0.375 | |
| | Tolerance area | Boundaries | x = 0.345 x = 0.405 | | y = 0.150 + 0.640 x y = 0.050 + 0.750 x | |
| | | Intersection points | x = 0.345 | | y = 0.371 | |
| | | | x = 0.405 | | y = 0.409 | |
| x = 0.405 | | | y = 0.354 | | | |
| x = 0.345 | | | y = 0.309 | | | |
| Hot re-strike switch-off time | | s | 10 | 10 | | |

^{1/} The part of the bulb within the angles α_1 and α_2 shall be the light emitting part. This part shall be as homogeneous in form as possible and shall be optically distortion free. This applies to the whole bulb circumference within the angles α_1 and α_2 .

^{2/} Application voltages of ballasts may differ from 12 V.

Categories D1S, D2S, D3S and D4S

Sheet DxS/5

Position of the electrodes

This test is used to determine whether the electrodes are correctly positioned relative to the reference axis and the reference plane.

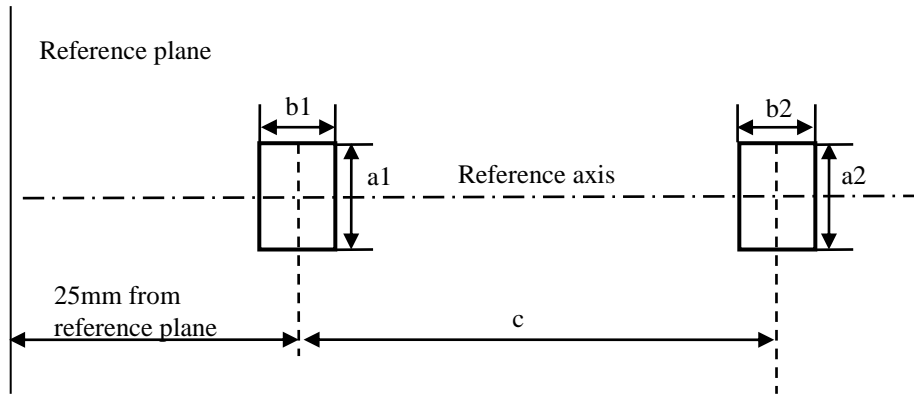

Measuring direction: light source side and top view

| <i>Dimension in mm</i> | <i>Production light sources</i> | <i>Standard light sources</i> |
|------------------------|---------------------------------|-------------------------------|
| a1 | $d + 0.2$ | $d + 0.1$ |
| a2 | $d + 0.5$ | $d + 0.25$ |
| b1 | 0.3 | 0.15 |
| b2 | 0.6 | 0.3 |
| c | 4.2 | 4.2 |

d = diameter of the electrode;
 $d < 0.3$ for D1S and D2S;
 $d < 0.4$ for D3S and D4S.

The top of the electrode nearest to the reference plane shall be positioned in the area defined by $a1$ and $b1$. The top of the electrode furthest from the reference plane shall be positioned in the area defined by $a2$ and $b2$.

Position and form of the arc

This test is used to determine the form of the arc and its position relative to the reference axis and the reference plane by measuring its bending and diffusion in the cross section at a distance 27.1 mm from the reference plane.

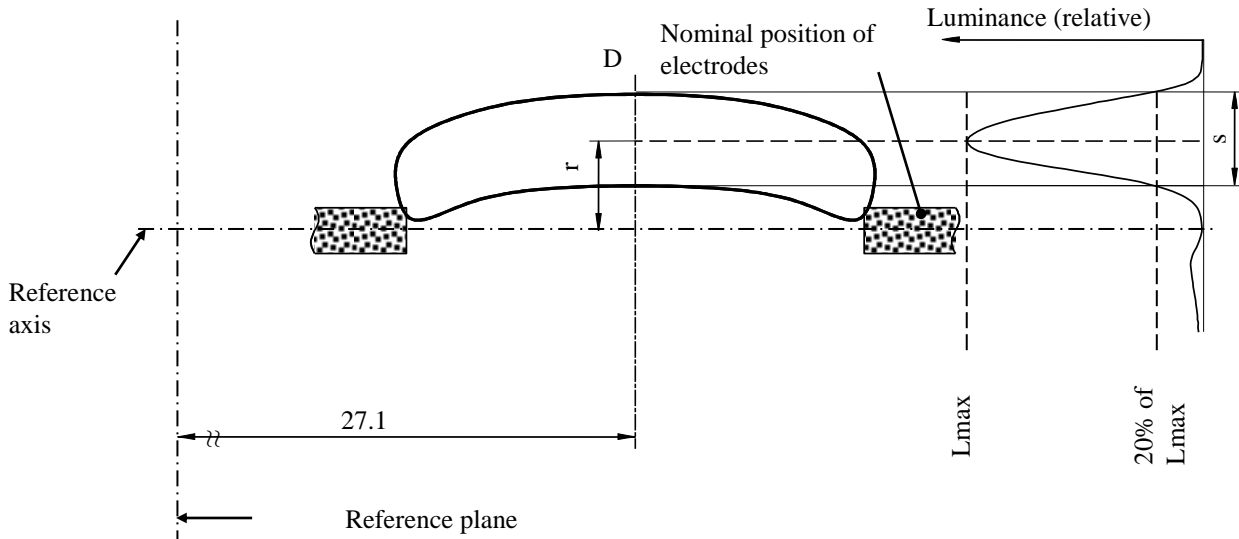

Relative luminance distribution in the central cross section D.

The form of the arc is for illustration purpose only.

Measuring direction B: light source side view

When measuring the relative luminance distribution in the central cross section as indicated in the drawing above, the maximum value shall be located within the distance r from the reference axis. The point of 20% of the maximum value shall be within s :

| <i>Dimension in mm</i> | <i>Production light sources</i> | <i>Standard light sources</i> |
|------------------------|---------------------------------|-------------------------------|
| r (arc bending) | 0.50 ± 0.40 | 0.50 ± 0.20 |
| s (arc diffusion) | 1.10 ± 0.40 | 1.10 ± 0.25 |

Category D5S

Sheet D5S/1

The drawings are intended only to illustrate the essential dimensions (in mm) of the gas-discharge light source

Figure 1
Main drawing of category D5S - Cap PK32d-7

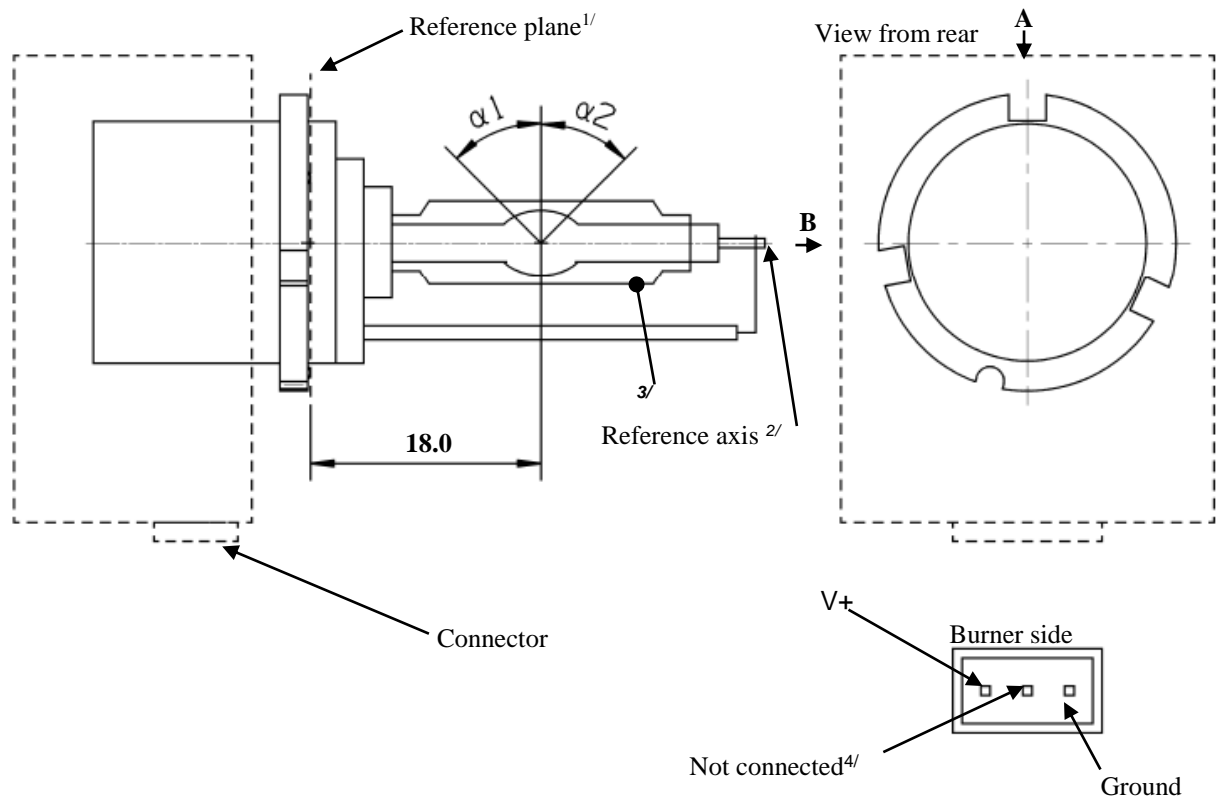

^{1/} The reference plane is defined by the positions on the surface of the holder on which the three supporting bosses of the cap ring will rest.

^{2/} See sheet D5S/2.

^{3/} When measured at a distance of 18.0 mm from the reference plane and with respect to the mid-point of the inner bulb, the outer bulb shall have an eccentricity of 1 mm max.

^{4/} Optional Pin.

Figure 2
Definition of reference axis^{1/}

The cap shall be pushed in this direction

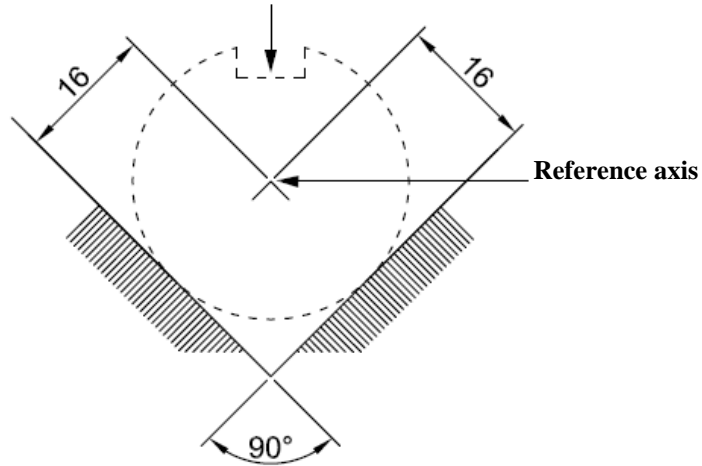
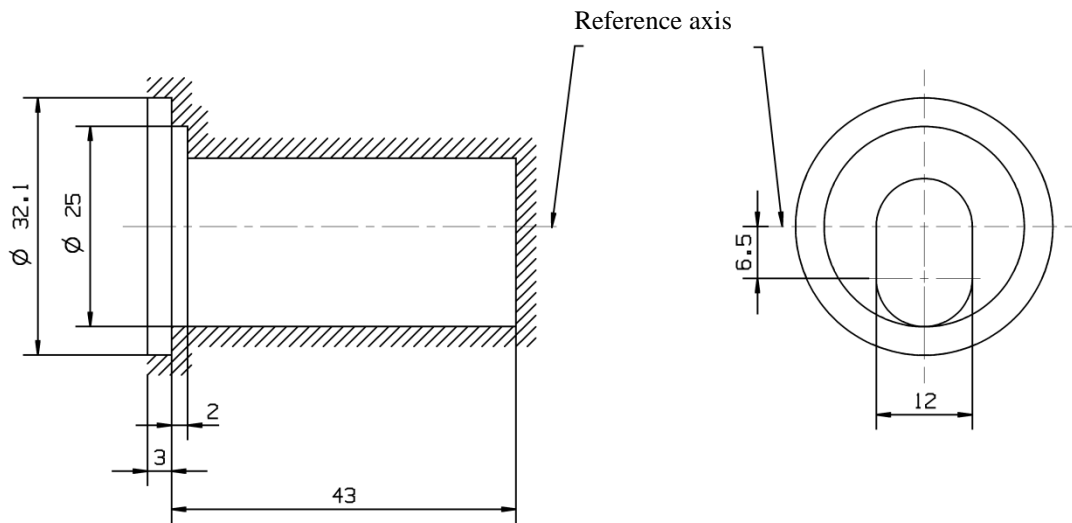

Figure 3
Maximum gas discharge light source outline^{2/}



^{1/} The reference axis is perpendicular to the reference plane and crosses the intersection of the two parallel lines as indicated in figure 2.

^{2/} Glass bulb and supports shall not exceed the envelope, as indicated in figure 3. The envelope is concentric with the reference axis.

Category D5S

Sheet D5S/3

| <i>Dimensions</i> | | <i>Production light sources</i> | <i>Standard light sources</i> | |
|--|----------------|-------------------------------------|-----------------------------------|---------------------|
| Position of the electrodes | | Sheet D5S/4 | | |
| Position and form of the arc | | Sheet D5S/5 | | |
| $\alpha 1, \alpha 2^{1/}$ | | 55° min. | 55° min. | |
| D5S: Cap PK32d-7 in accordance with IEC Publication 60061 (sheet 7004-111-5) | | | | |
| Electrical and photometric characteristics | | | | |
| Rated voltage | V | 12 / 24 | 12 / 24 | |
| Rated wattage | W | 25 | 25 | |
| Test voltage | V | 13.2 / 28 | 13.2 / 28 | |
| Objective gas discharge light source wattage ^{2/} | W | 31 max. | 31 max. | |
| Chromaticity coordinates | Objective | x = 0.375 | y = 0.375 | |
| | Tolerance area | Boundaries | x = 0.345 | y = 0.150 + 0.640 x |
| | | | x = 0.405 | y = 0.050 + 0.750 x |
| | | Intersection points | x = 0.345 | y = 0.371 |
| | | | x = 0.405 | y = 0.409 |
| | | | x = 0.405 | y = 0.354 |
| x = 0.345 | y = 0.309 | | | |
| Objective Luminous flux | lm | 2000 ± 300 | 2000 ± 100 | |
| Hot-restrike switch-off time | s | 10 | 10 | |

^{1/} The part of the bulb within the angles $\alpha 1$ and $\alpha 2$ shall be the light emitting part. This part shall be as homogeneous in form as possible and shall be optically distortion free. This applies to the whole bulb circumference within the angles $\alpha 1$ and $\alpha 2$.

^{2/} Wattage of gas discharge light source with ballast integrated.

Position of the electrodes

This test is used to determine whether the electrodes are correctly positioned relative to the reference axis and the reference plane.

Top view (schematic):

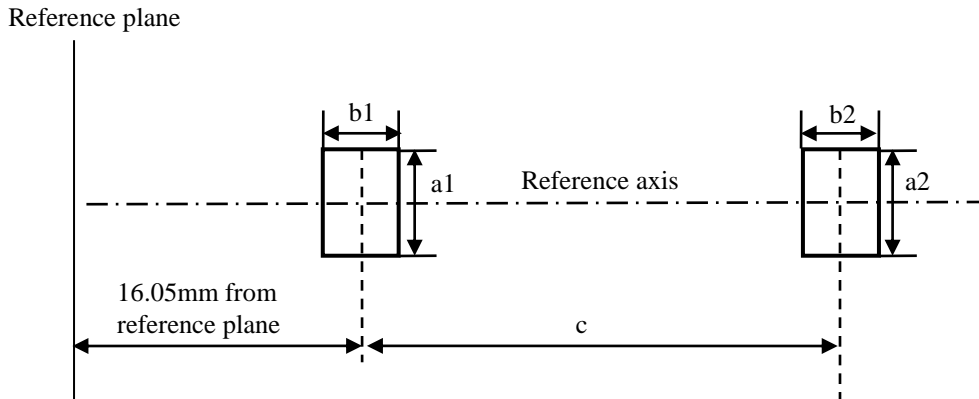

Side view (schematic):

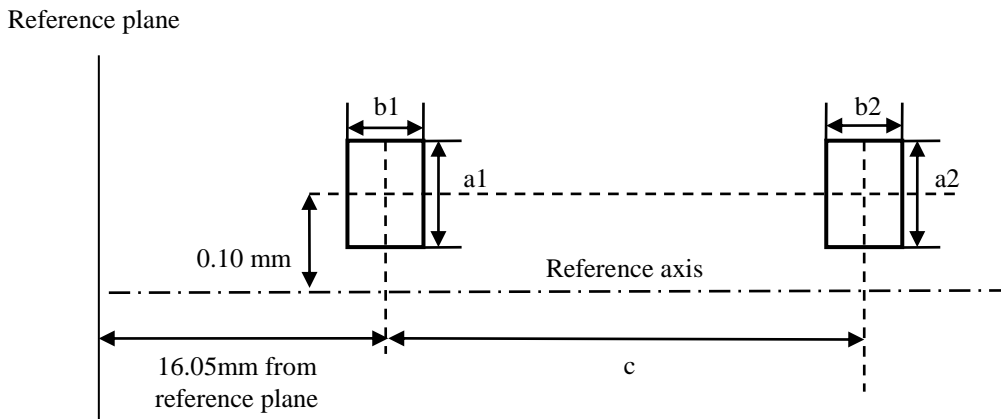

Measuring direction: light source side and top view

| Dimension in mm | Production light sources | Standard light sources |
|--------------------|-----------------------------|---------------------------|
| a1 | 0.30 | 0.20 |
| a2 | 0.50 | 0.25 |
| b1 | 0.30 | 0.15 |
| b2 | 0.60 | 0.30 |
| c | 3.90 | 3.90 |

The arc attachment point to the electrode nearest to the reference plane shall be positioned in the area defined by a1 and b1. The arc attachment point to the electrode furthest from the reference plane shall be positioned in the area defined by a2 and b2.

Position and form of the arc

This test is used to determine the form of the arc and its position relative to the reference axis and the reference plane by measuring its bending and diffusion in the cross section at a distance 18.0 mm from the reference plane.

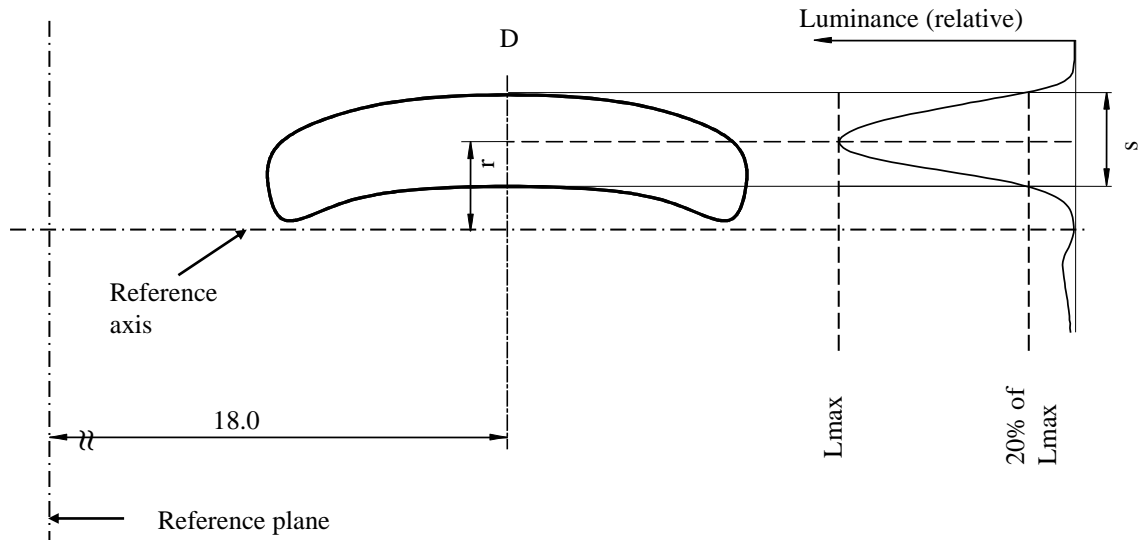

Relative luminance distribution in the central cross section D.

The form of the arc is for illustration purpose only.

Measuring direction: light source side view

When measuring the relative luminance distribution in the central cross section as indicated in the drawing above, the maximum value shall be located within the distance r from the reference axis. The point of 20 per cent of the maximum value shall be within s .

| <i>Dimension in mm</i> | <i>Production light sources</i> | <i>Standard light sources</i> |
|------------------------|---------------------------------|-------------------------------|
| r (arc bending) | 0.50 +/-0.25 | 0.50 +/-0.15 |
| s (arc diffusion) | 0.70 +/-0.25 | 0.70 +/-0.15 |

The drawings are intended only to illustrate the essential dimensions (in mm) of the gas-discharge light source

Figure 1

Main drawing of category D6S - Cap P32d-1

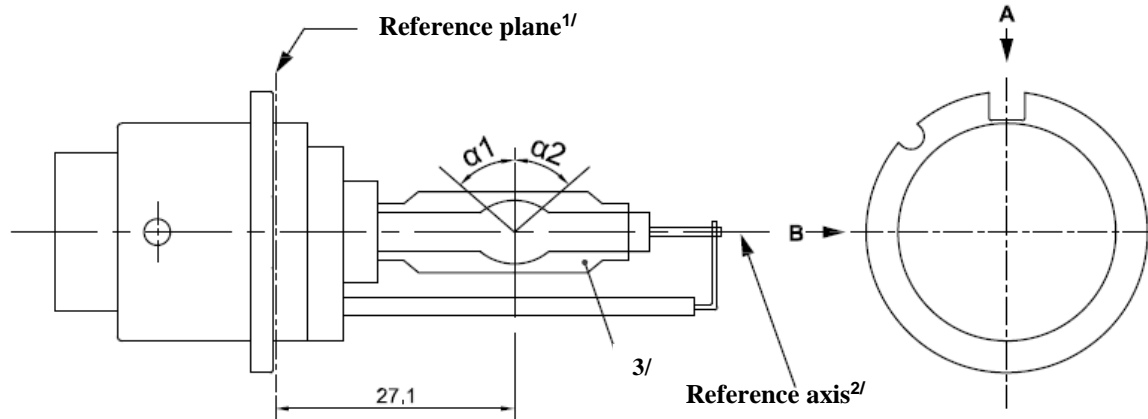

^{1/} The reference plane is defined by the positions on the surface of the holder on which the three supporting bosses of the cap ring will rest.

^{2/} See sheet D6S/2.

^{3/} When measured at a distance of 27.1 mm from the reference plane and with respect to the mid-point of the inner bulb, the outer bulb shall have an eccentricity of 1 mm max.

Figure 2
Definition of reference axis^{1/}

The cap shall be pushed in this direction

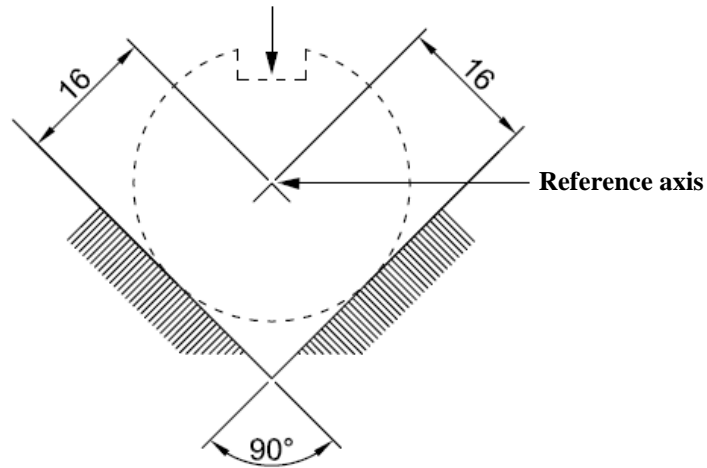
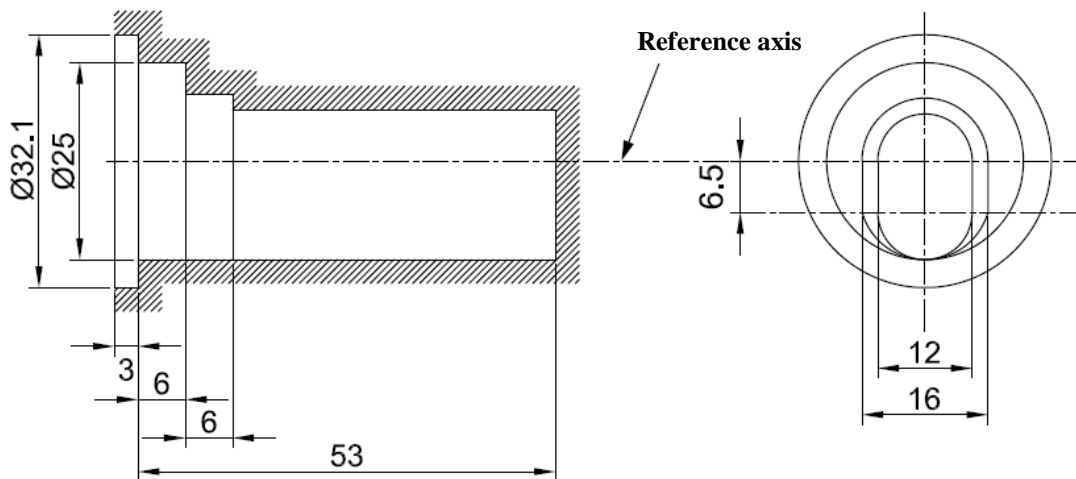

Figure 3
Maximum gas discharge light source outline^{2/}



^{1/} The reference axis is perpendicular to the reference plane and crosses the intersection of the two parallel lines as indicated in figure 2.

^{2/} Glass bulb and supports shall not exceed the envelope, as indicated in figure 3. The envelope is concentric with the reference axis.

| <i>Dimensions</i> | | <i>Production light sources</i> | <i>Standard light sources</i> | |
|---|----------------|-------------------------------------|-----------------------------------|---------------------|
| Position of the electrodes | | Sheet D6S/4 | | |
| Position and form of the arc | | Sheet D6S/5 | | |
| $\alpha 1, \alpha 2^{1/}$ | | 55° min. | 55° min. | |
| D6S: Cap P32d-1 in accordance with IEC Publication 60061 (sheet 7004-111-5) | | | | |
| Electrical and photometric characteristics | | | | |
| Rated voltage of the ballast | V | 12 ^{2/} | 12 | |
| Rated wattage | W | 25 | 25 | |
| Test voltage | V | 13.2 | 13.2 | |
| Objective gas discharge light source voltage | V | 42 ± 9 | 42 ± 4 | |
| Objective gas discharge light source wattage | W | 25 ± 3 | 25 ± 0.5 | |
| Objective Luminous flux | lm | 2000 ± 300 | 2000 ± 100 | |
| Chromaticity coordinates | Objective | x = 0.375 | y = 0.375 | |
| | Tolerance area | Boundaries | x = 0.345 | y = 0.150 + 0.640 x |
| | | | x = 0.405 | y = 0.050 + 0.750 x |
| | | Intersection points | x = 0.345 | y = 0.371 |
| | | | x = 0.405 | y = 0.409 |
| | | | x = 0.405 | y = 0.354 |
| x = 0.345 | y = 0.309 | | | |
| Hot-restrike switch-off time | s | 10 | 10 | |

^{1/} The part of the bulb within the angles $\alpha 1$ and $\alpha 2$ shall be the light emitting part. This part shall be as homogeneous in form as possible and shall be optically distortion free. This applies to the whole bulb circumference within the angles $\alpha 1$ and $\alpha 2$.

^{2/} Application voltages of ballasts may differ from 12 V.

Category D6S

Position of the electrodes

This test is used to determine whether the electrodes are correctly positioned relative to the reference axis and the reference plane.

Top view (schematic):

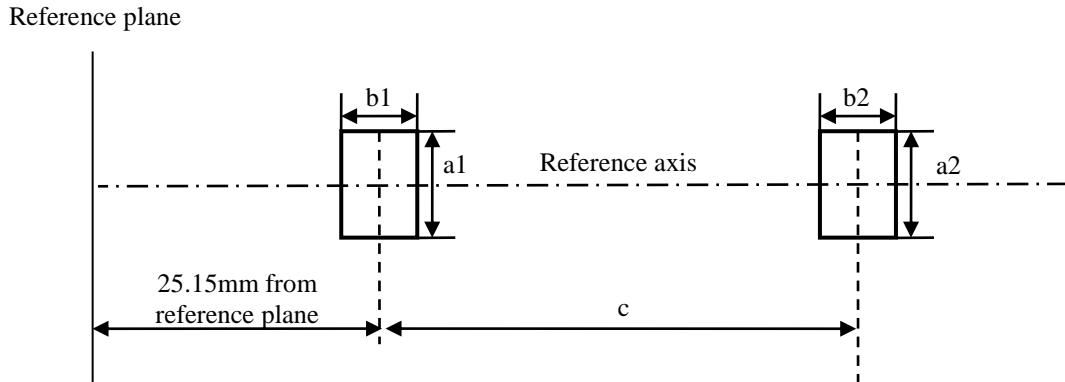

Side view (schematic):

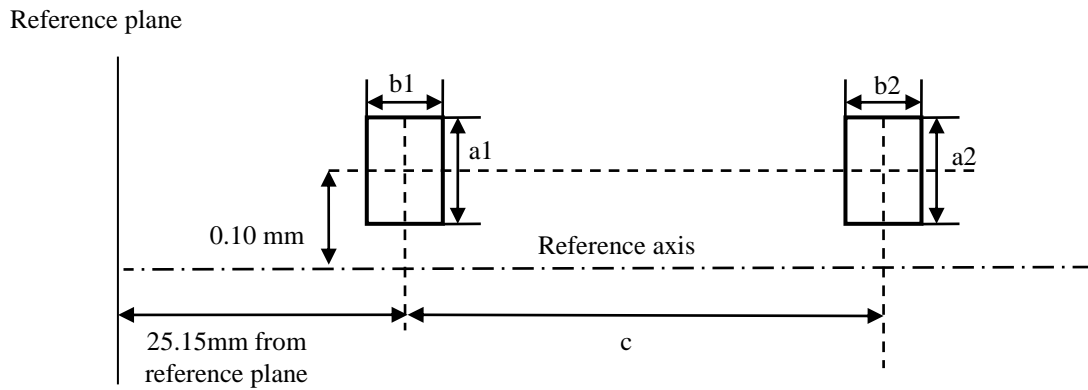

Measuring direction: light source side and top view

| Dimension in mm | Production light sources | Standard light sources |
|-----------------|--------------------------|------------------------|
| a1 | 0.30 | 0.20 |
| a2 | 0.50 | 0.25 |
| b1 | 0.30 | 0.15 |
| b2 | 0.60 | 0.30 |
| c | 3.90 | 3.90 |

The arc attachment point to the electrode nearest to the reference plane shall be positioned in the area defined by a1 and b1. The arc attachment point to the electrode furthest from the reference plane shall be positioned in the area defined by a2 and b2.

Position and form of the arc

This test is used to determine the form of the arc and its position relative to the reference axis and the reference plane by measuring its bending and diffusion in the cross section at a distance 27.1 mm from the reference plane.

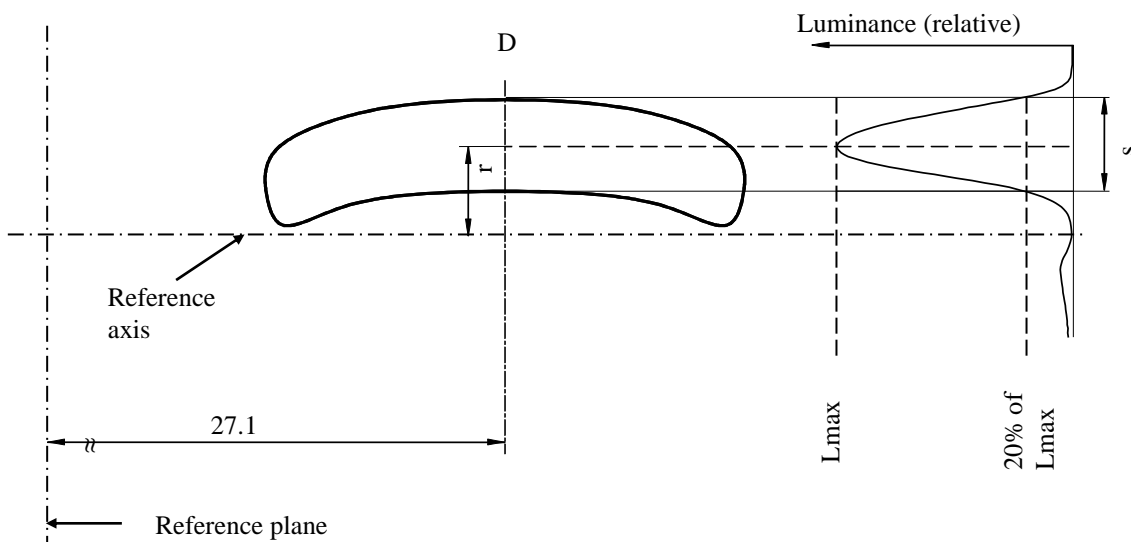

Relative luminance distribution in the central cross section D.

The form of the arc is for illustration purpose only.

Measuring direction: light source side view

When measuring the relative luminance distribution in the central cross section as indicated in the drawing above, the maximum value shall be located within the distance r from the reference axis. The point of 20 per cent of the maximum value shall be within s .

| <i>Dimension in mm</i> | <i>Production light sources</i> | <i>Standard light sources</i> |
|------------------------|---------------------------------|-------------------------------|
| r (arc bending) | 0.50 +/-0.25 | 0.50 +/-0.15 |
| s (arc diffusion) | 0.70 +/-0.25 | 0.70 +/-0.15 |

The drawings are intended only to illustrate the essential dimensions (in mm)
of the gas-discharge light source

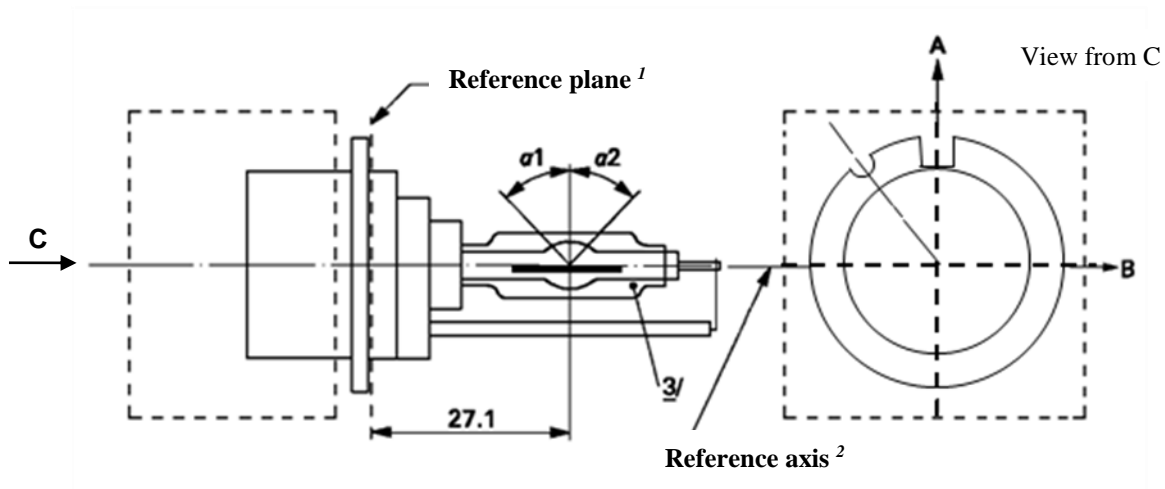

Figure 1
Main drawing of category D8R - Cap PK32d-8

- ¹ The reference plane is defined by the positions on the surface of the holder on which the three supporting bosses of the cap ring will rest.
- ² See sheet D8R/2.
- ³ When measured at a distance of 27.1 mm from the reference plane and with respect to the mid-point of the inner bulb, the outer bulb shall have an eccentricity of 1 mm max.

The cap shall be pushed in this direction

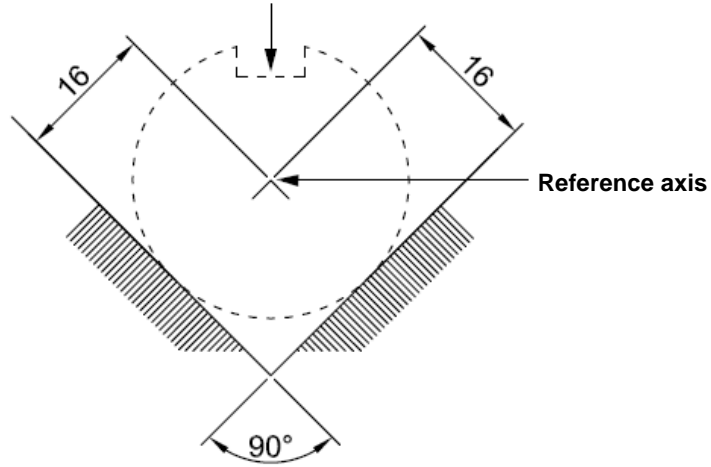

Figure 2
Definition of reference axis¹

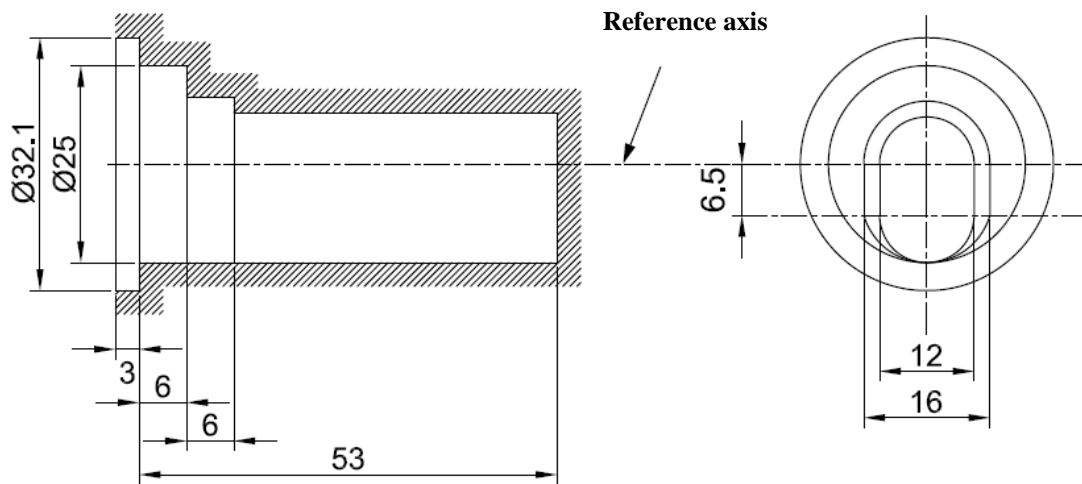

Figure 3
Maximum gas discharge light source outline²

¹ The reference axis is perpendicular to the reference plane and crosses the intersection of the two parallel lines as indicated in figure 2.

² Glass bulb and supports shall not exceed the envelope, as indicated in figure 3. The envelope is concentric with the reference axis.

Category D8R

Sheet D8R/3

| <i>Dimensions</i> | | <i>Production light sources</i> | <i>Standard light sources</i> |
|---|-------------------|-------------------------------------|------------------------------------|
| Position of the electrodes | | Sheet D8R/4 | |
| Position and form of the arc | | Sheet D8R/5 | |
| α_1^1 | | 55° min. | |
| α_2^1 | | 55° min. | |
| D8R: Cap PK32d-8 in accordance with IEC Publication 60061(sheet 7004-111-5) | | | |
| Electrical and photometric characteristics | | | |
| Rated voltage of the ballast | V | 12 ² | 12 |
| Rated wattage | W | 25 | 25 |
| Test voltage | V | 13.2 | 13.2 |
| Objective gas discharge light source voltage | V | 42 ± 9 | 42 ± 4 |
| Objective gas discharge light source wattage | W | 25 ± 3 | 25 ± 0.5 |
| Objective Luminous flux | lm | 1900 ± 300 | 1900 ± 100 |
| Chromaticity coordinates | Objective | x = 0.375 | y = 0.375 |
| | Tolerance area | Boundaries | x = 0.345 y = 0.150 + 0.640 x |
| | | | x = 0.405 y = 0.050 + 0.750 x |
| | | Intersection points | x = 0.345 y = 0.371 |
| | | | x = 0.405 y = 0.409 |
| | | x = 0.405 y = 0.354 | |
| | | x = 0.345 y = 0.309 | |
| Hot-restrike switch-off time | s | 10 | 10 |

¹ The part of the bulb within the angles α_1 and α_2 shall be the light emitting part. This part shall be as homogeneous in form as possible and shall be optically distortion free. This applies to the whole bulb circumference within the angles α_1 and α_2 except for the black stripes.

² Application voltages of ballasts may differ from 12 V.

Position of the electrodes

This test is used to determine whether the electrodes are correctly positioned relative to the reference axis and the reference plane.

Top view (schematic):

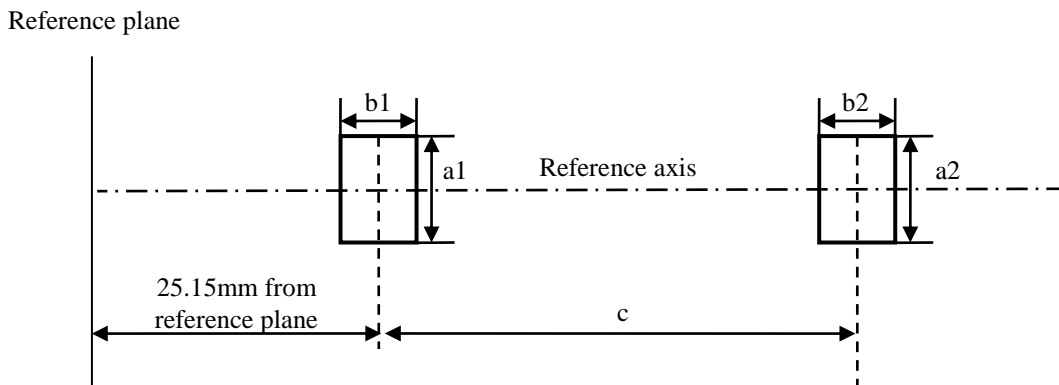

Side view (schematic):

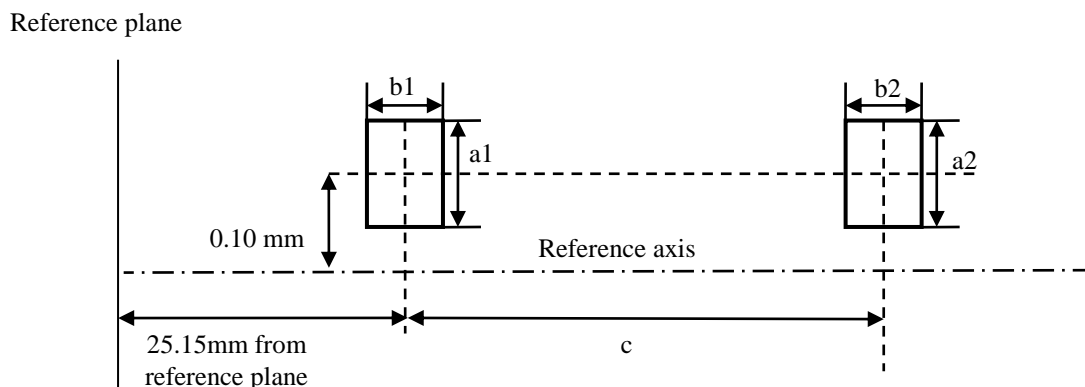

Measuring direction: light source side and top view

| Dimension in mm | Production light sources | Standard light sources |
|--------------------|-----------------------------|---------------------------|
| a1 | 0.50 | 0.20 |
| a2 | 0.70 | 0.35 |
| b1 | 0.40 | 0.15 |
| b2 | 0.80 | 0.30 |
| c | 3.90 | 3.90 |

The arc attachment point to the electrode nearest to the reference plane shall be positioned in the area defined by a1 and b1. The arc attachment point to the electrode furthest from the reference plane shall be positioned in the area defined by a2 and b2.

Category D8R

Sheet D8R/5

Position and form of the arc

This test is used to determine the form of the arc and its position relative to the reference axis and the reference plane by measuring its bending and diffusion in the cross section at a distance 27.1 mm from the reference plane.

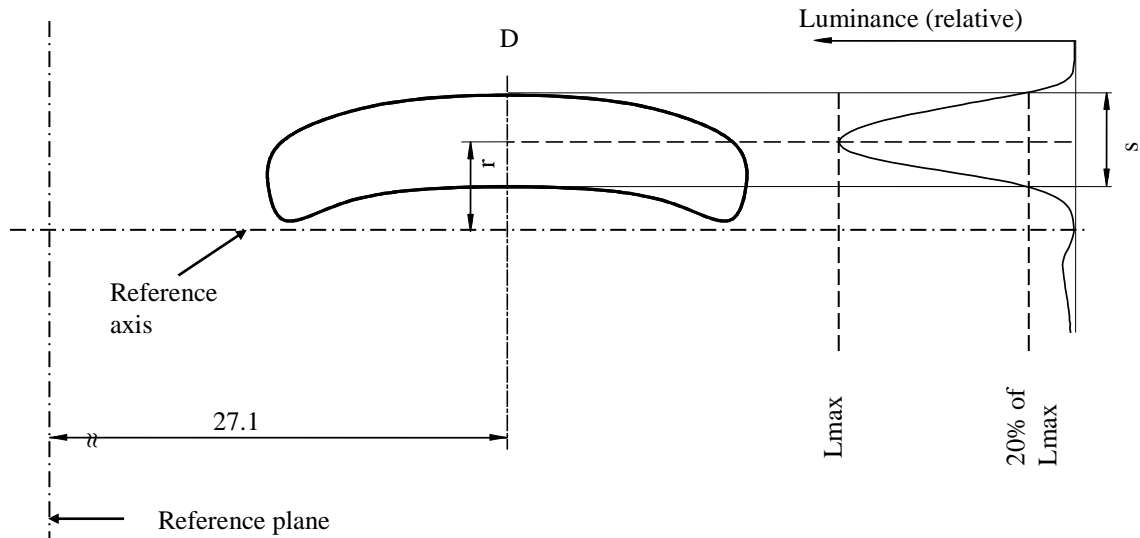

Relative luminance distribution in the central cross section D.

The form of the arc is for illustration purpose only.

Measuring direction: light source side view

When measuring the relative luminance distribution in the central cross section as indicated in the drawing above, the maximum value shall be located within the distance r from the reference axis. The point of 20 per cent of the maximum value shall be within s .

| <i>Dimension in mm</i> | <i>Production light sources</i> | <i>Standard light sources</i> |
|------------------------|---------------------------------|-------------------------------|
| r (arc bending) | 0.50 +/- 0.25 | 0.50 +/- 0.15 |
| s (arc diffusion) | 0.70 +/- 0.25 | 0.70 +/- 0.15 |

Position of black stripes

This test is used to determine whether the black stripes are correctly positioned relative to the reference axis and the reference plane.

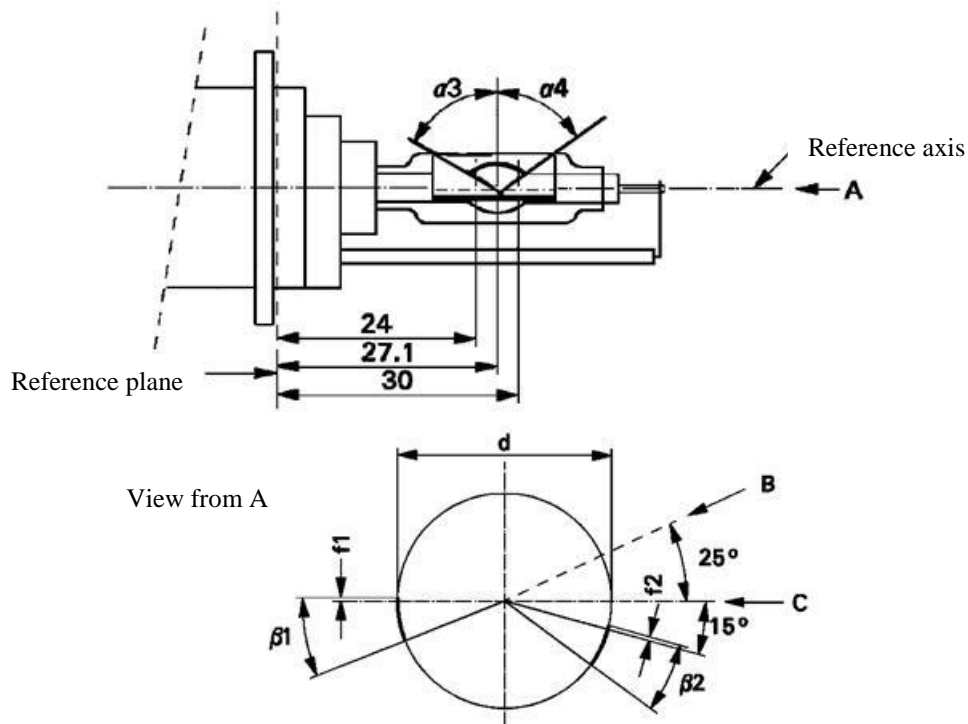

When measuring the luminance distribution of the arc in the central cross section as defined on sheet D8R/5, after having turned the light source so that the black stripe is covering the arc, the measured luminance shall be $\leq 0.5\%$ of L_{max} .

| Dimensions | Production light sources | Standard light sources |
|--|---|-----------------------------|
| α_3 | 70° min. | |
| α_4 | 65° min. | |
| $\beta_1/24, \beta_1/30, \beta_2/24, \beta_2/30$ | 25° ± 5° | |
| $f_1/24, f_2/24$ ¹ | 0 ± 0.25 | 0 ± 0.20 |
| $f_1/30$ ¹ | $f_1/24 \text{ mv} \pm 0.15$ ² | $f_1/24 \text{ mv} \pm 0.1$ |
| $f_2/30$ ¹ | $f_2/24 \text{ mv} \pm 0.15$ ² | $f_2/24 \text{ mv} \pm 0.1$ |
| $f_1/24 \text{ mv} - f_2/24 \text{ mv}$ | ± 0.3 max. | ± 0.2 max. |
| d | 9 ± 1 | |

¹ "f1/.." means dimension f1 to be measured at the distance from the reference plane indicated in mm after the stroke.

² ".../24 mv" means the value measured at a distance of 24 mm from the reference plane.

The drawings are intended only to illustrate the essential dimensions (in mm)

Figure 1
Main drawing of category D8S - Cap PK32d-1

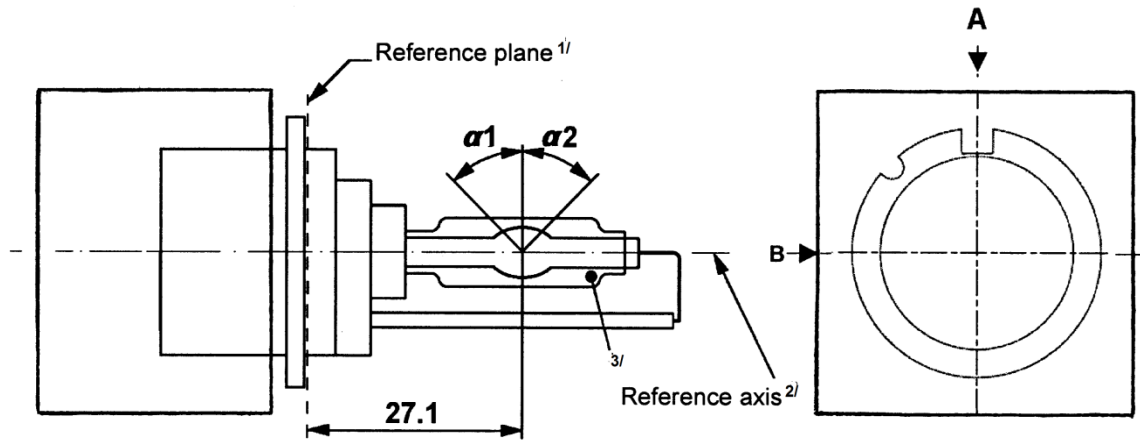

^{1/} The reference plane is defined by the positions on the surface of the holder on which the three supporting bosses of the cap ring will rest.

^{2/} See sheet D8S/2.

^{3/} When measured at a distance of 27.1 mm from the reference plane and with respect to the mid-point of the inner bulb, the outer bulb shall have an eccentricity of 1 mm max.

Figure 2
Definition of reference axis^{1/}

The cap shall be pushed in this direction

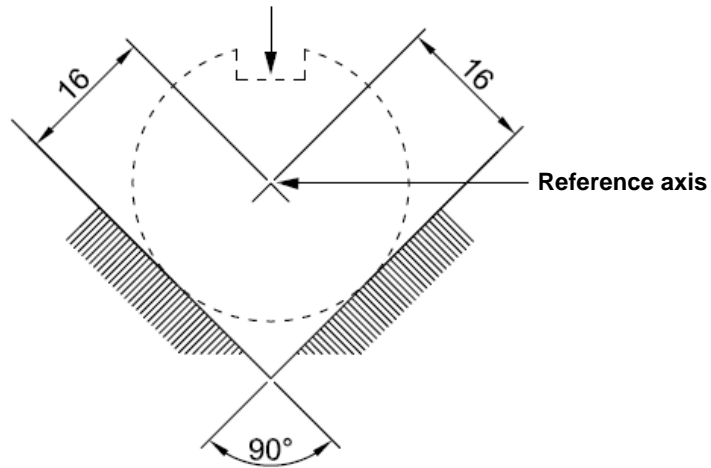
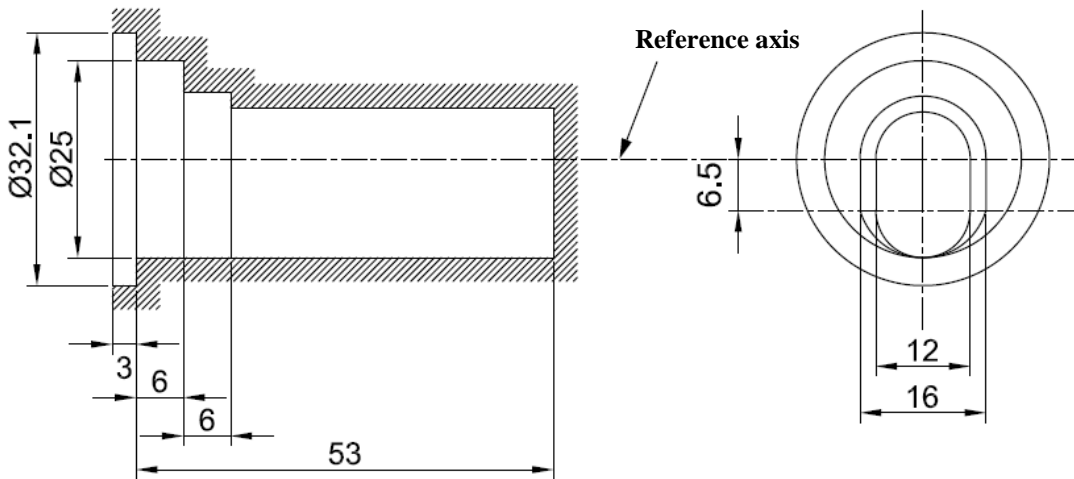

Figure 3
Maximum gas discharge light source outline^{2/}



^{1/} The reference axis is perpendicular to the reference plane and crosses the intersection of the two parallel lines as indicated in figure 2.

^{2/} Glass bulb and supports shall not exceed the envelope, as indicated in figure 3. The envelope is concentric with the reference axis.

Category D8S

Sheet D8S/3

| <i>Dimensions</i> | | <i>Production light sources</i> | <i>Standard light sources</i> |
|--|----------------|-------------------------------------|--|
| Position of the electrodes | | Sheet D8S/4 | |
| Position and form of the arc | | Sheet D8S/5 | |
| $\alpha_1, \alpha_2^{1/}$ | | 55° min. | 55° min. |
| D8S: Cap PK32d-1 in accordance with IEC Publication 60061 (sheet 7004-111-5) | | | |
| Electrical and photometric characteristics | | | |
| Rated voltage of the ballast | V | 12 ^{2/} | 12 |
| Rated wattage | W | 25 | 25 |
| Test voltage | V | 13.2 | 13.2 |
| Objective gas discharge light source voltage | V | 42 ± 9 | 42 ± 4 |
| Objective gas discharge light source wattage | W | 25 ± 3 | 25 ± 0.5 |
| Objective Luminous flux | lm | 2000 ± 300 | 2000 ± 100 |
| Chromaticity coordinates | Objective | | x = 0.375 y = 0.375 |
| | Tolerance area | Boundaries | x = 0.345 y = 0.150 + 0.640 x |
| | | | x = 0.405 y = 0.050 + 0.750 x |
| | | Intersection points | x = 0.345 y = 0.371 |
| | | | x = 0.405 y = 0.409 |
| | | | x = 0.405 y = 0.354 |
| x = 0.345 y = 0.309 | | | |
| Hot-restrike switch-off time | s | 10 | 10 |

^{1/} The part of the bulb within the angles α_1 and α_2 shall be the light emitting part. This part shall be as homogeneous in form as possible and shall be optically distortion free. This applies to the whole bulb circumference within the angles α_1 and α_2 .

^{2/} Application voltages of ballasts may differ from 12 V.

Position of the electrodes

This test is used to determine whether the electrodes are correctly positioned relative to the reference axis and the reference plane.

Top view (schematic):

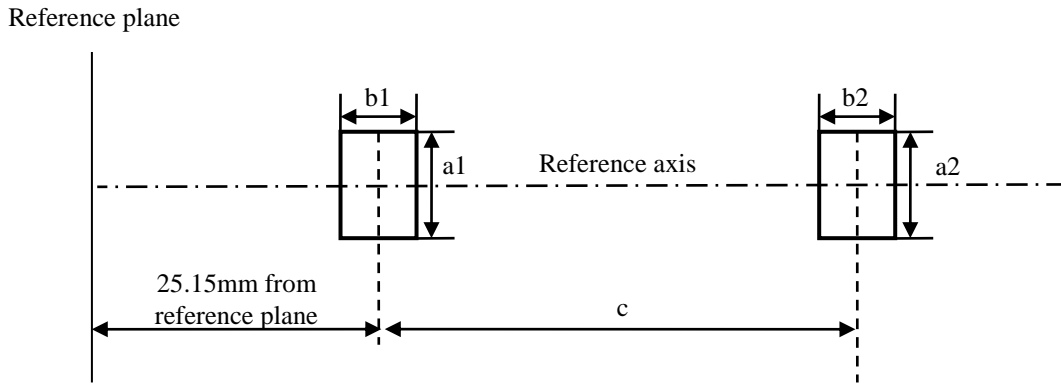

Side view (schematic):

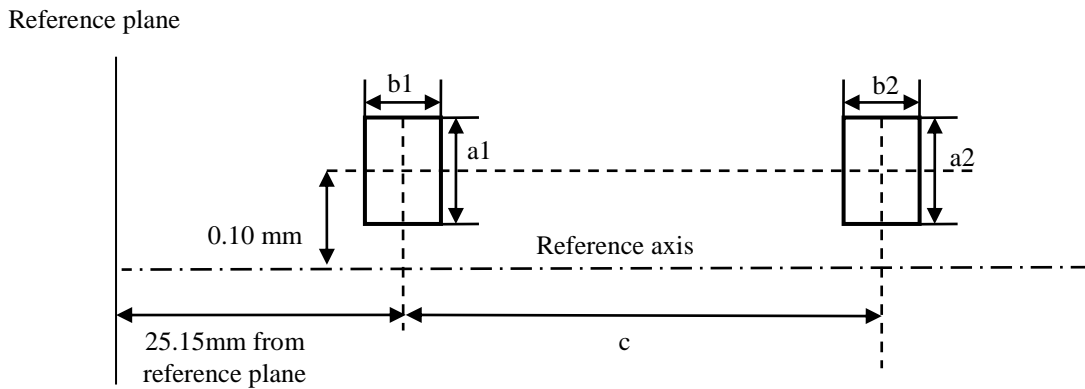

Measuring direction: light source side and top view

| Dimension in mm | Production light sources | Standard light sources |
|--------------------|-----------------------------|---------------------------|
| a1 | 0.30 | 0.20 |
| a2 | 0.50 | 0.25 |
| b1 | 0.30 | 0.15 |
| b2 | 0.60 | 0.30 |
| c | 3.90 | 3.90 |

The arc attachment point to the electrode nearest to the reference plane shall be positioned in the area defined by a1 and b1. The arc attachment point to the electrode furthest from the reference plane shall be positioned in the area defined by a2 and b2.

Position and form of the arc

This test is used to determine the form of the arc and its position relative to the reference axis and the reference plane by measuring its bending and diffusion in the cross section at a distance 27.1 mm from the reference plane.

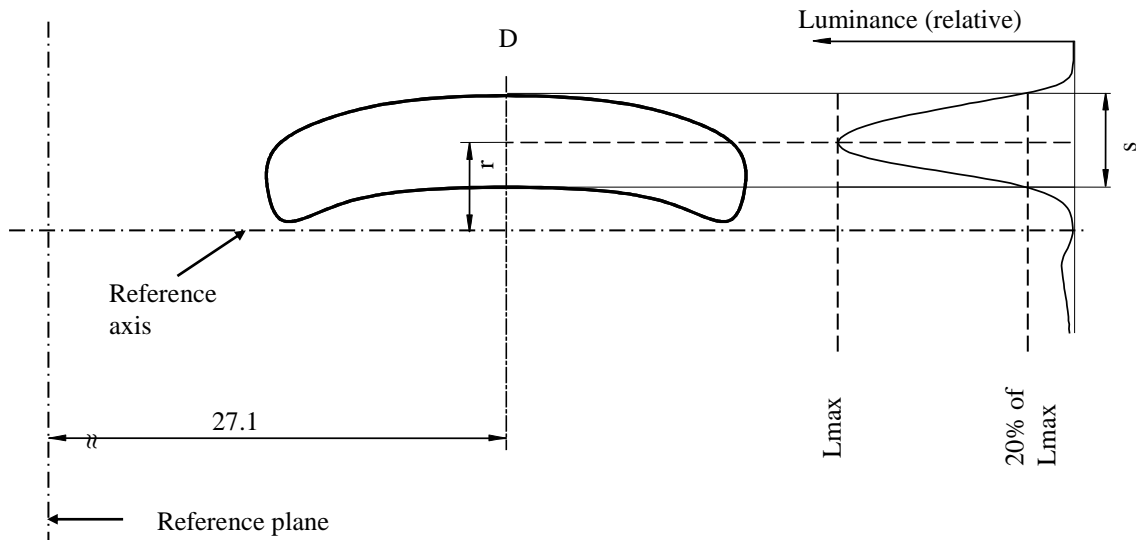

Relative luminance distribution in the central cross section D. The form of the arc is for illustration purpose only. Measuring direction: light source side view

When measuring the relative luminance distribution in the central cross section as indicated in the drawing above, the maximum value shall be located within the distance r from the reference axis. The point of 20 per cent of the maximum value shall be within s.

| <i>Dimension in mm</i> | <i>Production light sources</i> | <i>Standard light sources</i> |
|------------------------|---------------------------------|-------------------------------|
| r (arc bending) | 0.50 +/- 0.25 | 0.50 +/- 0.15 |
| s (arc diffusion) | 0.70 +/- 0.25 | 0.70 +/- 0.15 |

The drawings are intended only to illustrate the essential dimensions (in mm)

Figure 1
Main drawing of category D9S - Cap PK32d-9

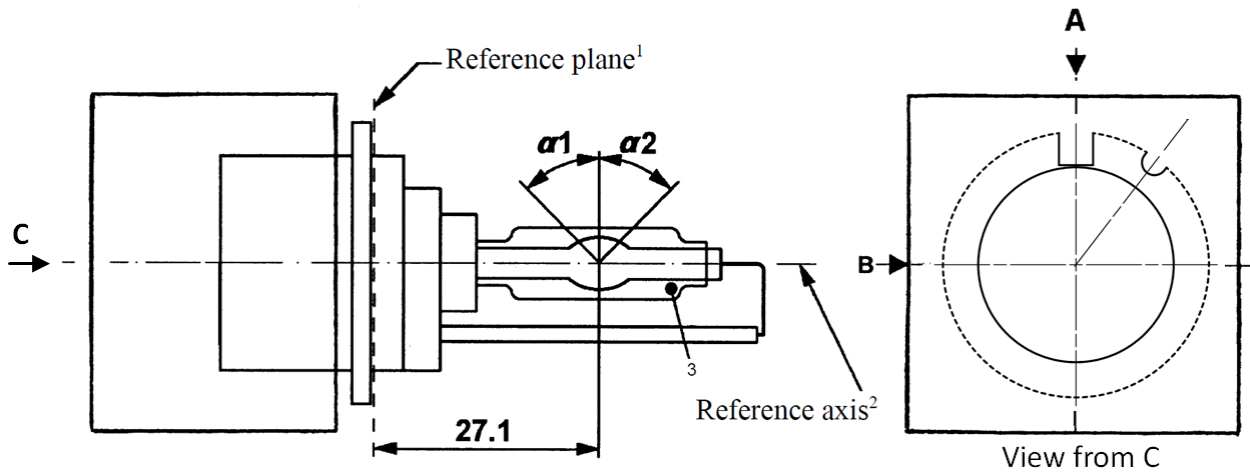

¹ The reference plane is defined by the positions on the surface of the holder on which the three supporting bosses of the cap ring will rest.

² See sheet D9S/2.

³ When measured at a distance of 27.1 mm from the reference plane and with respect to the mid-point of the inner bulb, the outer bulb shall have an eccentricity of 1 mm max.

Figure 2
Definition of reference axis¹

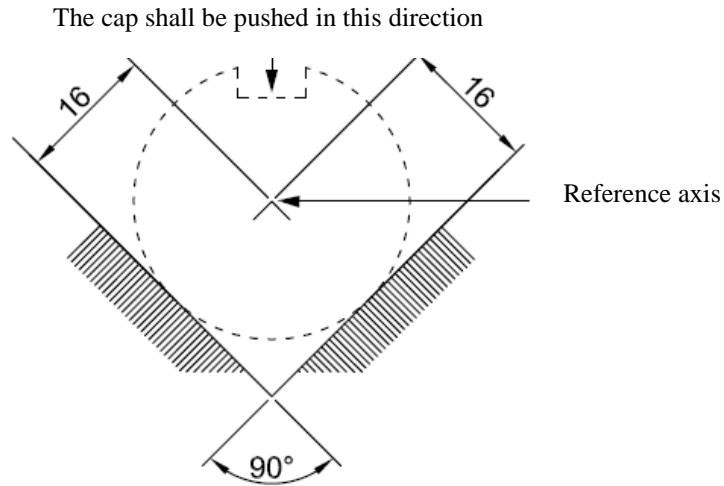
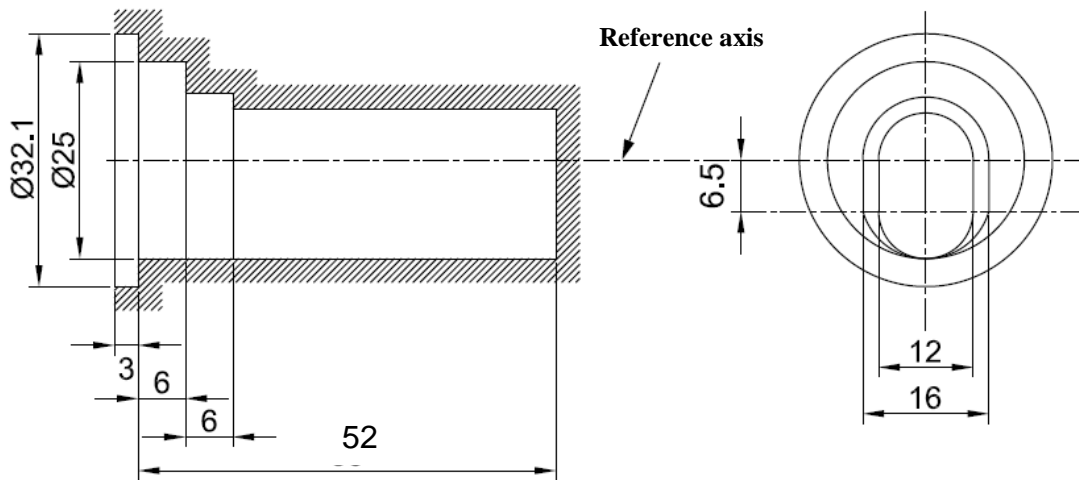

Figure 3
Maximum gas discharge light source outline²



¹ The reference axis is perpendicular to the reference plane and crosses the intersection of the two parallel lines as indicated in figure 2.

² Glass bulb and supports shall not exceed the envelope, as indicated in figure 3. The envelope is concentric with the reference axis.

Category D9S

Sheet D9S/3

| <i>Dimensions</i> | | <i>Production light sources</i> | | <i>Standard light sources</i> | | |
|--|----------------|---------------------------------|------------|-------------------------------|---------------------|--|
| Position of the electrodes | | Sheet D9S/4 | | | | |
| Position and form of the arc | | Sheet D9S/5 | | | | |
| α_1, α_2 ¹ | | 55° min. | | 55° min. | | |
| D9S: Cap PK32d-9 in accordance with IEC Publication 60061 (sheet 7004-111-5) | | | | | | |
| Electrical and photometric characteristics | | | | | | |
| Rated voltage of the ballast | V | 12 ² | | 12 | | |
| Rated wattage | W | 27 | 35 | 27 | 35 | |
| Test voltage | V | 13.5 | | 13.5 | | |
| Objective gas discharge light source voltage | V | 34 ± 6 | 38 ± 8 | 34 ± 4 | 38 ± 4 | |
| Objective gas discharge light source wattage | W | 27 ± 3 | 35 ± 3 | 27 ± 0.5 | 35 ± 0.5 | |
| Objective Luminous flux | lm | 2000 ± 300 | 3000 ± 450 | 2000 ± 100 | 3000 ± 150 | |
| Chromaticity coordinates | Objective | x = 0.375 | | y = 0.375 | | |
| | Tolerance area | Boundaries | x = 0.345 | | y = 0.150 + 0.640 x | |
| | | | x = 0.405 | | y = 0.050 + 0.750 x | |
| | | Intersection points | x = 0.345 | | y = 0.371 | |
| | | | x = 0.405 | | y = 0.409 | |
| | | | x = 0.405 | | y = 0.354 | |
| | | x = 0.345 | | y = 0.309 | | |
| Hot-restrike switch-off time | s | 10 | | 10 | | |

¹ The part of the bulb within the angles α_1 and α_2 shall be the light emitting part. This part shall be as homogeneous in form as possible and shall be optically distortion free. This applies to the whole bulb circumference within the angles α_1 and α_2 .

² Application voltages of ballasts may differ from 12 V.

Category D9S

Sheet D9S/4

Position of the electrodes

This test is used to determine whether the electrodes are correctly positioned relative to the reference axis and the reference plane.

Side and top view (schematic):

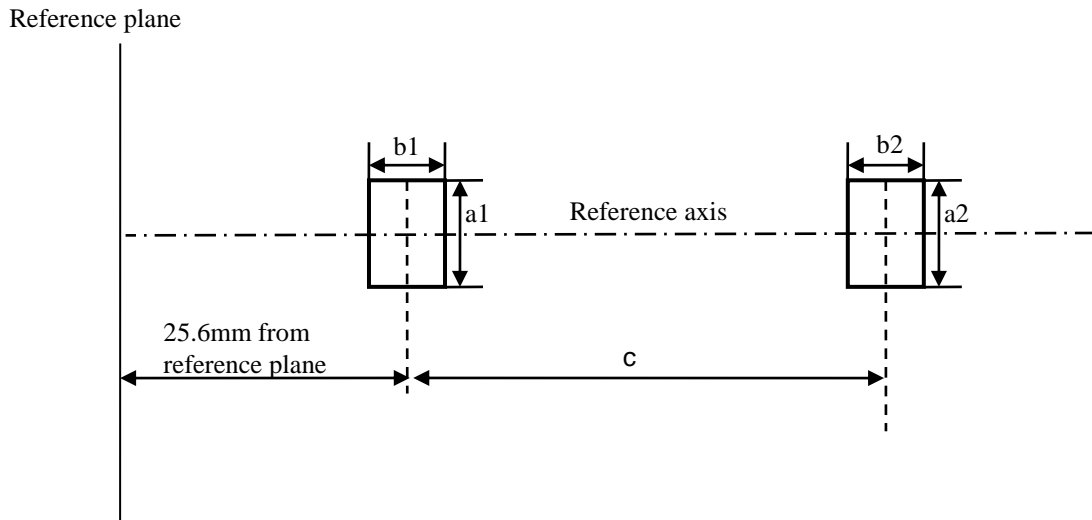

Measuring direction: light source side and top view

| <i>Dimension in mm</i> | <i>Production light sources</i> | <i>Standard light sources</i> |
|----------------------------|-------------------------------------|-----------------------------------|
| a1 | 0.30 | 0.20 |
| a2 | 0.50 | 0.25 |
| b1 | 0.30 | 0.15 |
| b2 | 0.60 | 0.30 |
| c | 3.00 | 3.00 |

The arc attachment point to the electrode nearest to the reference plane shall be positioned in the area defined by a1 and b1. The arc attachment point to the electrode furthest from the reference plane shall be positioned in the area defined by a2 and b2. The geometrical data is valid for 27W and 35W operation.

Position and form of the arc

This test is used to determine the form of the arc and its position relative to the reference axis and the reference plane by measuring its bending and diffusion in the cross section at a distance 27.1 mm from the reference plane.

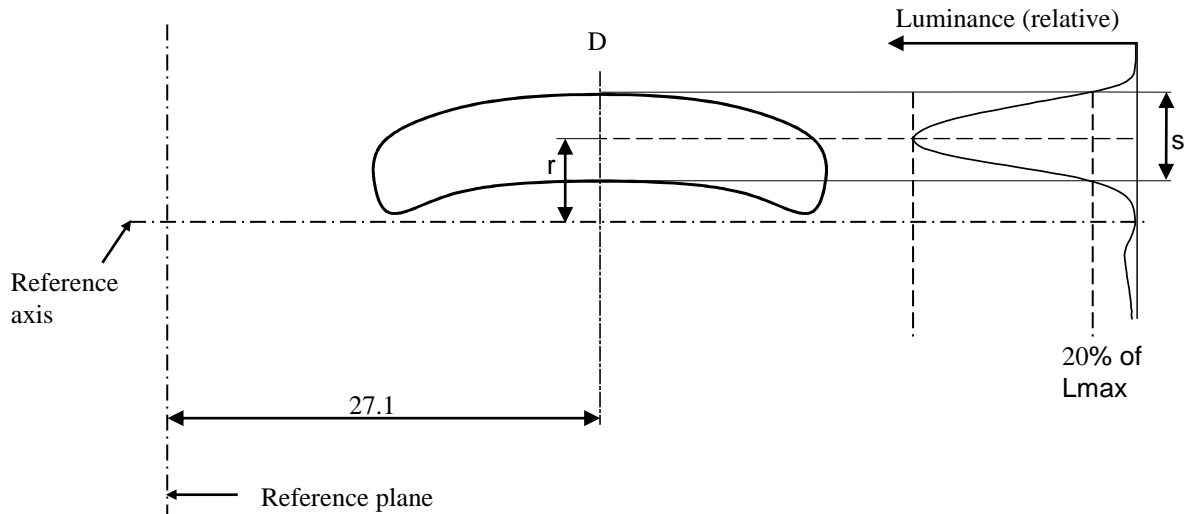

Relative luminance distribution in the central cross section D.

The form of the arc is for illustration purpose only.

Measuring direction: light source side view

When measuring the relative luminance distribution in the central cross section as indicated in the drawing above, the maximum value shall be located within the distance r from the reference axis. The point of 20 per cent of the maximum value shall be within s . The geometrical data is valid for 27W and 35W operation.

| <i>Dimension in mm</i> | <i>Production light sources</i> | <i>Standard light sources</i> |
|------------------------|---------------------------------|-------------------------------|
| r (arc bending) | 0.35 +/- 0.25 | 0.35 +/- 0.15 |
| s (arc diffusion) | 0.80 +/- 0.25 | 0.80 +/- 0.15 |

Annex 3

Sheets for LED light sources

List of sheets for LED light sources and their sequence in this annex:

Sheet number(s)

LR1/1 to 5

LW2/1 to 5

L3/1 to 6

LR4/1 to 5

L5/1 to 6

The drawings are intended only to illustrate the essential dimensions (in mm) of the LED light source

Figure 1
Main drawing

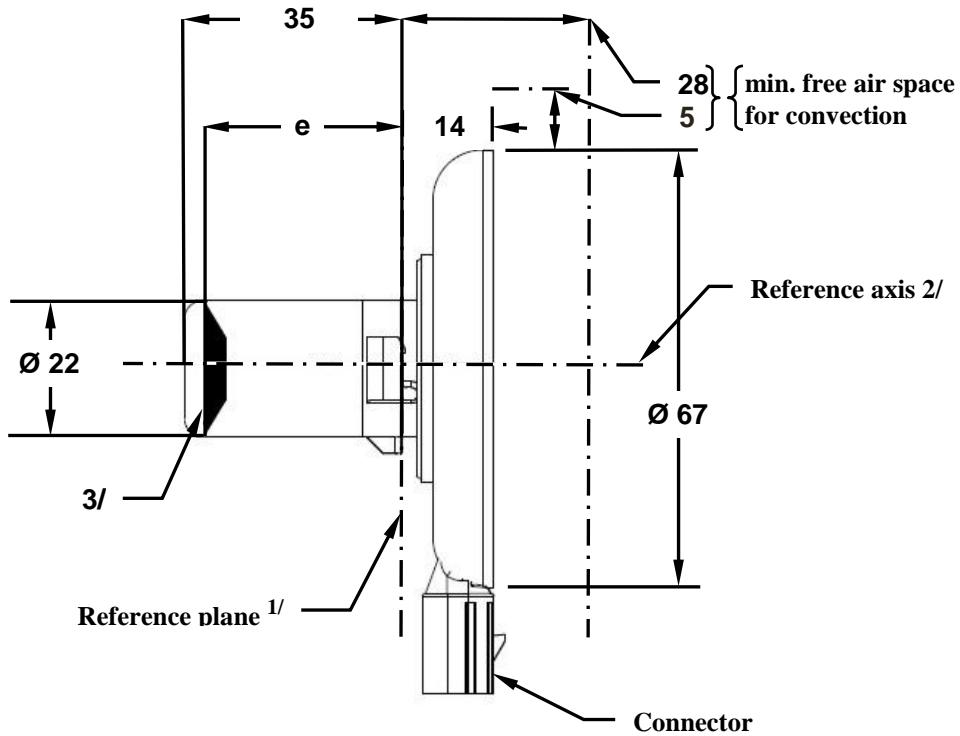
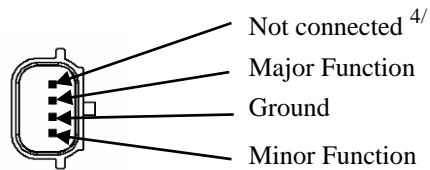

Figure 2
Connector detail



1/ The reference plane is the plane defined by the contact points of the cap-holder fit.
 2/ The reference axis is perpendicular to the reference plane and passing through the centre of the bayonet core.
 3/ Light emitting area: to be checked by means of the box system in Figure 3.
 4/ Optional pin.

Table 1
Essential dimensional, electrical and photometric characteristics

| Dimensions in mm | | Tolerance | | | |
|--|--|--|----------------------|---------------------------|----------------------|
| | | LED light sources of normal production | | Standard LED light source | |
| e ^{3/ 7/} | 24.0 | 0.2 | | 0.1 | |
| Cap PGJ21t-1 in accordance with IEC Publication 60061 (sheet 7004-165-1) | | | | | |
| Electrical and photometric characteristics ^{5/} | | | | | |
| Rated values | | Minor function | Major function | Minor function | Major function |
| | Volts | 12 | | 12 | |
| Objective Values ^{6/} | Watts (at 13.5 V DC) | 0.75 max. | 3.5 max. 1.4 min. | 0.75 max. | 3.5 max. 1.4 min. |
| | Luminous flux (in lm at 13.5V DC) | | | 3.5 ± 10% | 47 ± 10% |
| | Luminous flux (in lm at 10-16 V DC) | 3.5 ± 20% | 47 ± 20% | | |

^{5/} The emitted light shall be red.

^{6/} Continuous on for 30 minutes at $23 \pm 2.5^\circ \text{C}$.

^{7/} Light centre length.

Failure condition behaviour

In case of LED light source failure (no light emitted) the maximum current draw – when operated within the input voltage range in major function mode – operation shall be less than 20 mA (open circuit condition).

Screen projection requirements

The following test is intended to define the requirements for the light emitting area of the LED light source and to determine whether the light emitting area is correctly positioned relative to the reference axis and reference plane in order to check compliance with the requirements.

The position of the light emitting area is checked by the box system defined in Figure 3, which shows the projections when viewing along direction $\gamma=90^\circ$ in the planes C_{90} and C_{180} (C , γ as defined in Figure 4). At least 95 per cent of the luminous flux emitted into the viewing direction has to come from the trapezoidal area defined by d1, d2 and c. Less than 70 per cent of the luminous flux shall be emitted from the rectangular area defined by d3 and c.

Figure 3
Box definition of the light emitting area

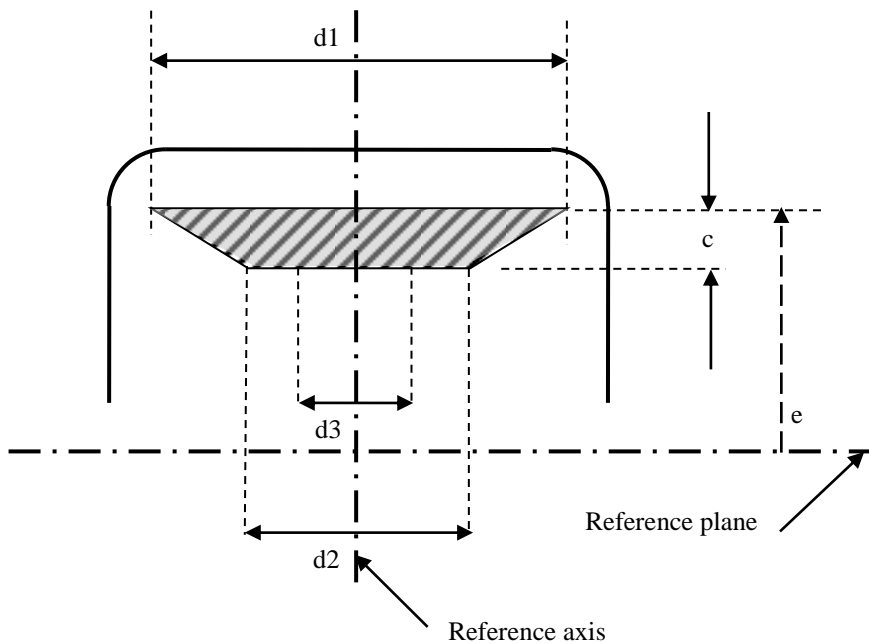

Table 2
Dimensions of the box system in Figure 3

| <i>Dimensions in mm</i> | <i>e</i> | <i>c</i> | <i>d1</i> | <i>d2</i> | <i>d3</i> |
|--|------------|----------|-----------|-----------|-----------|
| LED light sources of normal production | 24.0 + 0.2 | 3.6 | 21.0 | 15.0 | 7.0 |
| Standard (etalon) LED light sources | 24.0 + 0.1 | 3.4 | 21.0 | 15.0 | 7.0 |

Normalized luminous intensity distribution

The following test is intended to determine the normalized luminous intensity distribution of the LED light source in an arbitrary plane containing the reference axis. The intersection of the reference axis and the upper edge of the box is used as the coordinate system origin.

The LED light source is mounted on a flat plate with the corresponding mounting lug features. The plate is mounted to the goniometer table by a bracket, so that the reference axis of the LED light source lines up with one of the rotating axis of the goniometer. The corresponding measurement set-up is described in Figure 4.

The drawings are intended only to illustrate the essential set-up for measurement of the LED light source

Figure 4
Set-up to measure the luminous intensity distribution

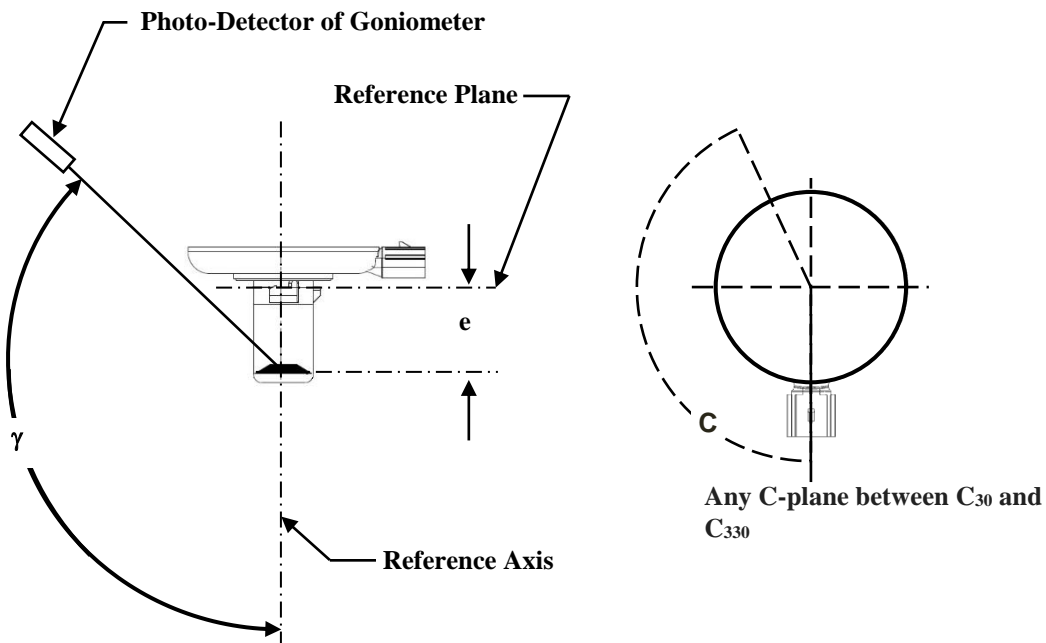

Luminous intensity data is recorded for the major function with a standard photogoniometer. The measurement distance should be chosen appropriately, to make sure that the detector is located in the far field of the light distribution.

The measurements shall be performed in 3 C-planes, which contain the reference axis of the LED light source. The 3 C-planes shall be within C_{30} and C_{330} to avoid the connector shadows and they have to be at least 30° apart from each other. The test points for each plane for multiple polar angles γ are specified in Table 3.

The measured luminous intensity values, normalised to the measured luminous flux of the individual LED light source under test, shall be converted to normalised luminous intensity values of a 1000 lm LED light source. The data shall comply with the tolerance band as defined in Table 3.

C-planes: see CIE publication 70-1987, "The measurement of absolute intensity distributions".

Table 3

Test point values of normalized intensity for the major function of normal production and standard LED light sources, respectively.

| γ | <i>LED light source of normal production</i> | | <i>Standard LED light source</i> | |
|----------|--|--|---|--|
| | <i>Minimum intensity in cd /1000 lm</i> | <i>Maximum intensity in cd/1000 lm</i> | <i>Minimum intensity in cd /1000 lm</i> | <i>Maximum intensity in cd/1000 lm</i> |
| 0° | 0 | 30 | 0 | 20 |
| 15° | 0 | 30 | 0 | 20 |
| 30° | 0 | 70 | 0 | 40 |
| 45° | 20 | 100 | 20 | 60 |
| 60° | 35 | 120 | 35 | 80 |
| 75° | 50 | 140 | 50 | 100 |
| 90° | 70 | 160 | 70 | 120 |
| 105° | 90 | 180 | 90 | 140 |
| 120° | 110 | 200 | 110 | 160 |
| 135° | 110 | 200 | 110 | 160 |
| 150° | 90 | 180 | 90 | 140 |

The luminous intensity distribution as described in Table 3 shall be substantially uniform, i.e. in between two adjacent grid points the relative luminous intensity requirement is calculated by linear interpolation using the two adjacent grid points.

The drawings are intended only to illustrate the essential dimensions (in mm) of the LED light source

Figure 1
Main Drawing – front and side view

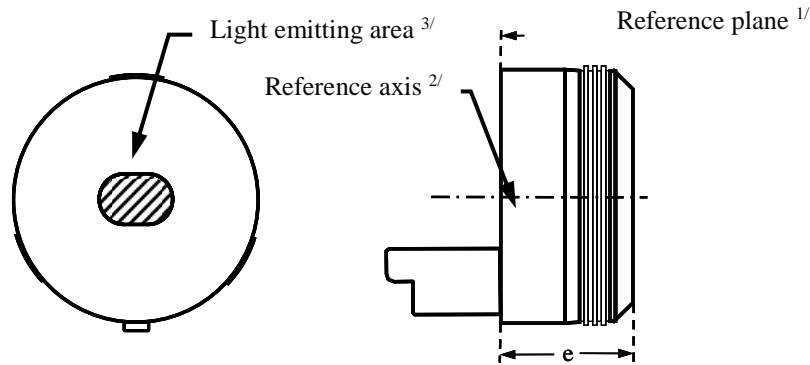

Figure 2 – Connector Detail

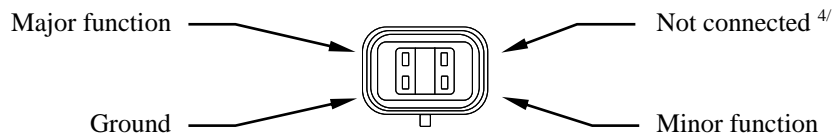

Table 1

Essential dimensional, electrical and photometric characteristics

| Dimensions in mm | | Tolerances | | | |
|--|-------------------------------------|--|-------------------|----------------------------|-------------------|
| | | LED light sources of normal production | | Standard LED light sources | |
| e ^{8/} | 26.4 | 0.2 | | 0.1 | |
| Cap PGJY50 in accordance with IEC Publication 60061 (sheet 7004-182-1) | | | | | |
| Electrical and photometric characteristics ^{5/} | | | | | |
| Rated values | | Minor function | Major function | Minor function | Major function |
| | Volts | 12 | | 12 | |
| Objective Values ^{6/7/} | Watts (at 13.5 V DC) | 1 max. | 12 max. 4 min. | 1 max. | 12 max. 4 min. |
| | Luminous flux (in lm at 13.5V DC) | | | 50 ± 10% | 725 ± 10% |
| | Luminous flux (in lm at 10-16 V DC) | 50 ± 15% | 725 ± 15% | | |
| Corresponding base temperature T _b in °C | | 30 ± 2 | 55 ± 2 | 30 ± 0.5 | 55 ± 0.5 |

^{1/} The reference plane is given by the thermal transfer area on the backside of the LED light source.
^{2/} The reference axis is perpendicular to the reference plane and passing through the centre of the LED light source as defined by three notches on the outer perimeter.
^{3/} Light emitting area: to be checked by means of the box system in Figure 3.
^{4/} Optional pin.
^{5/} The emitted light shall be white.
^{6/} Continuous operation for 30 minutes with base temperature T_b stabilized as specified above.
^{7/} Luminous flux from the light emitting area shall be determined within a solid angle of - 40° < α < + 40° and - 40° < β < +40° using either integral methods or the procedure described on sheets LW2/3 and LW2/4.
^{8/} Light centre length.

Screen projection requirements

This test is intended to determine whether the light emitting area of the LED light source is correctly positioned relative to the reference axis and reference plane.

Compliance of position and dimension as defined in Table 2 is checked by the box system shown in Figure 3. The left drawing displays the projection when viewing along the reference axis with an aperture acceptance angle of $\pm 40^\circ$ while the right drawing defines the position of the reference plane and axis.

Size determination shall be done with suitable means.

Figure 3

Box definition of light emitting area

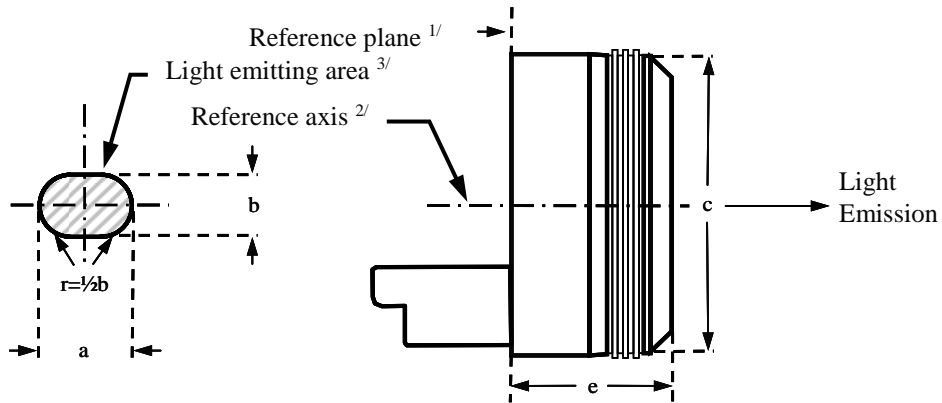

Table 2

Dimensions of the light emitting area in Figure 3

| <i>Dimensions in mm</i> | <i>e</i> | <i>a</i> | <i>b</i> | <i>c</i> |
|--|----------------|----------------|----------------|-----------------------------|
| LED light sources of normal production | 26.4 ± 0.2 | $14.5 +0/-2.5$ | $10.1 +0/-1.5$ | $\text{Ø } 50.00 + 0.10/-0$ |
| Standard (Etalon) LED light sources | 26.4 ± 0.1 | $14.5 +0/-2.5$ | $10.1 +0/-1.5$ | $\text{Ø } 50.05 + 0.05/-0$ |

Cumulative luminous flux distribution

Measurement set-up

This test is intended to determine the cumulative luminous flux within defined solid angles of the luminous intensity distribution.

Goniophotometers of type I or II according to CIE publication No. 70 -1987 with the capability of turning the LED light source around two axes perpendicular to the axis of light emission can be used. The intersection of the reference axis and the parallel plane to the reference plane in distance e is used as the coordinate system origin.

Figure 4

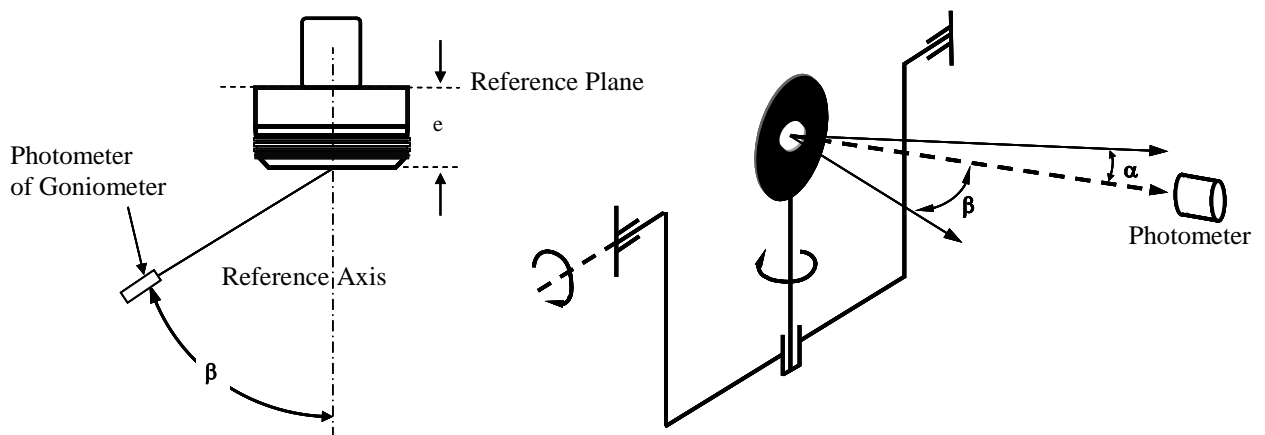
Set-up to measure the luminous intensity distribution using a type I photogoniometer

The LED light source is mounted on a flat plate with the corresponding mounting lug features. The plate is mounted to the goniometer table by a bracket in such way, that the reference axis of the LED light source lines up with the measurement axis of the goniometer. The corresponding measurement set-up is described in Figure 4.

Cumulative luminous flux distribution

Measurement and calculation procedure

Data shall be recorded for the specified base temperature T_b from Table 1 at the location shown in Fig. 5.

Luminous intensity distribution data shall be recorded within a solid angle of $-40^\circ < \alpha < +40^\circ$ and $-40^\circ < \beta < +40^\circ$. The measurement distance shall be chosen in such manner that the detector is located in the far field of the light distribution. An angular step size of 1° or less is required.

After the measurement, the cumulative luminous flux distribution shall be calculated from the recorded data for various solid angles as specified in Table 3 according to CIE publication 84-1989, section 4.3. Subsequently, the distribution shall be normalized to the total luminous flux determined for $-40^\circ < \alpha < +40^\circ$ and $-40^\circ < \beta < +40^\circ$. The data shall comply with the tolerance band defined in Table 3.

In order to secure a symmetrical distribution within each solid angle in Table 3 the luminous flux determination shall be done independently for all 4 quadrants and flux values shall not differ by more than 15%.

Table 3

Test point values of normalized cumulative luminous flux for both normal production and standard LED light sources

| <i>Angle α, β</i> | <i>Min. normalized flux in %</i> | <i>Max. normalized flux in %</i> |
|---|----------------------------------|----------------------------------|
| $-5^\circ < \alpha, \beta < +5^\circ$ | 8 | 14 |
| $-10^\circ < \alpha, \beta < +10^\circ$ | 31 | 37 |
| $-15^\circ < \alpha, \beta < +15^\circ$ | 54 | 59 |
| $-20^\circ < \alpha, \beta < +20^\circ$ | 75 | 81 |
| $-25^\circ < \alpha, \beta < +25^\circ$ | 91 | 95 |
| $-30^\circ < \alpha, \beta < +30^\circ$ | 97 | 100 |
| $-35^\circ < \alpha, \beta < +35^\circ$ | 98 | 100 |
| $-40^\circ < \alpha, \beta < +40^\circ$ | 100 (by definition) | |

The cumulative luminous flux distribution of the minor function may be verified by measuring the ratio of major and minor function under a fixed angle and multiplication of this factor with the luminous flux of the major function.

In case of doubt that cumulative luminous flux distributions of major and minor function differ, the procedure as described above for the major function shall be repeated for the minor function.

Thermal interface geometry

The LW2 thermal interface is located within the reference plane (shaded area in Figure 5) and described in detail in IEC Publication 60061 as indicated in Table 1 on sheet LW2/1. It shall be attached to an appropriate heat sink or thermal management system.

The luminous flux given in Table 1 shall be achieved once the base temperature T_b measured at the location shown in Figure 5 is stabilized.

Figure 5

Rear-view: thermal contact area and location of T_b -point on the vertical symmetry axis, at a distance f from the center

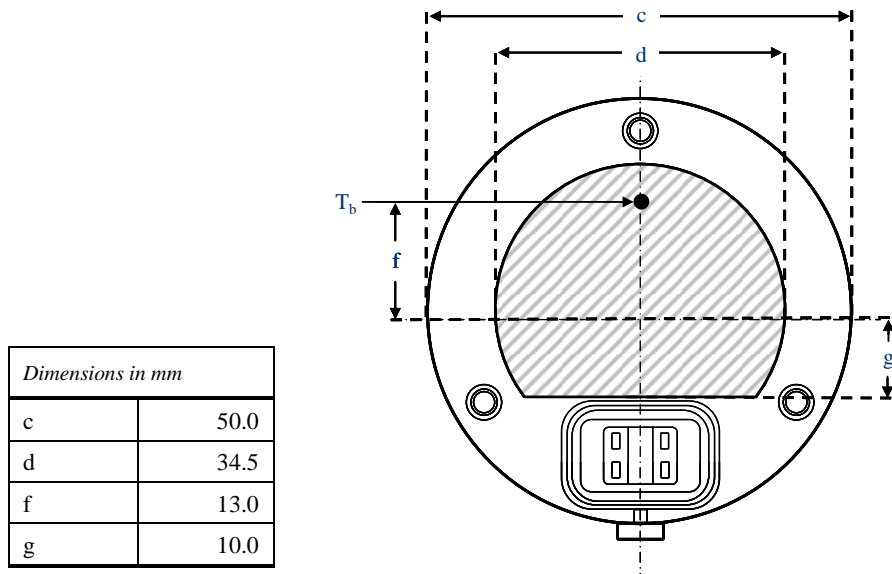

Failure condition behaviour

In case of LED light source failure (no light emitted) the maximum current draw – when operated within the input voltage range in major function mode – shall be less than 20 mA (open circuit condition).

The drawings are intended only to illustrate the essential dimensions of the LED light source.

Figure 1*

Main Drawing

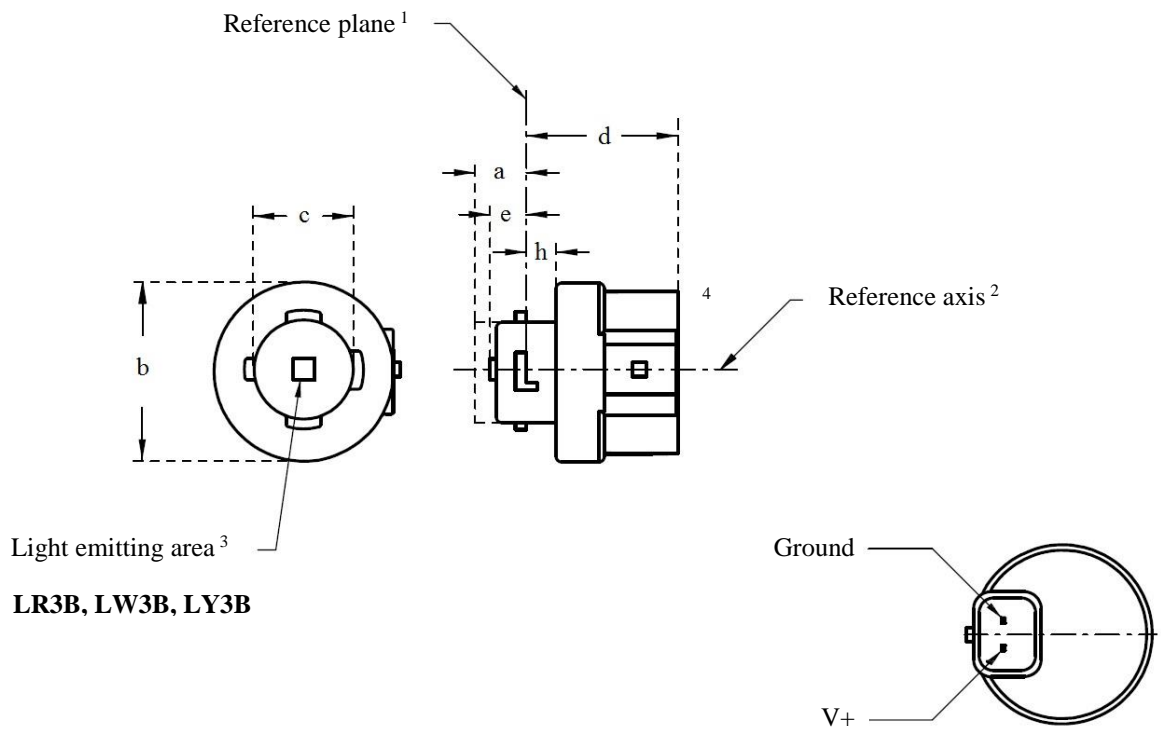
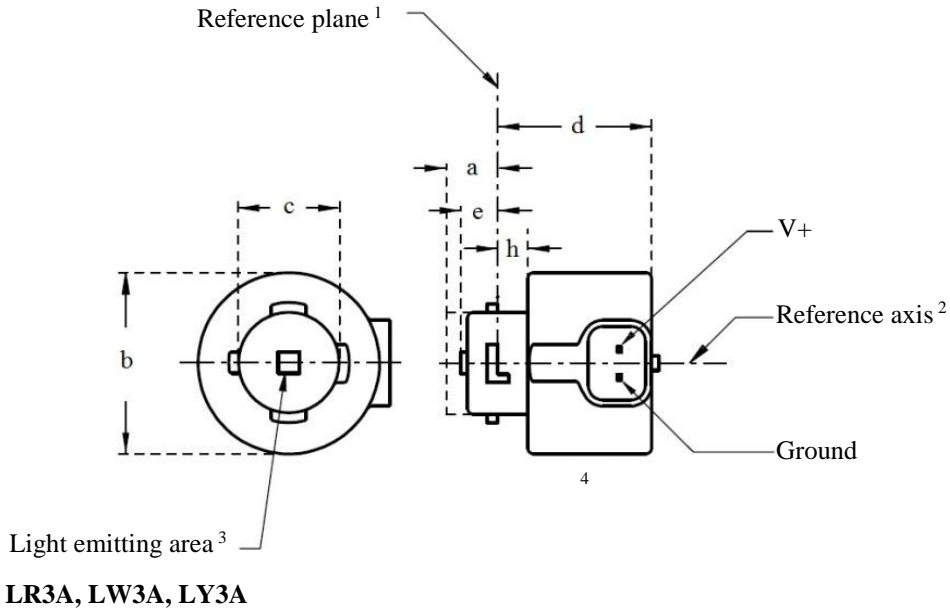

For the notes see sheet L3/2.

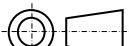
* Projection method: 

Categories LR3A, LR3B, LW3A, LW3B, LY3A and LY3B

Sheet L3/2

Table 1
Essential dimensional, electrical and photometric characteristics of the LED light source

| Dimensions | | Production LED light sources | Standard LED light sources | |
|--|--|--|---|-------------------------|
| a | mm | 6.0 max. | | |
| b | mm | c + 10.0 min. 38.0 max. | | |
| c | mm | 18.5 ± 0.1 | | |
| d | mm | 28.0 max. | | |
| e ^{13/} | mm | 3.0 ± 0.30 | 3.0 ± 0.15 | |
| h | mm | 5.5 + 0.0/ - 0.1 | | |
| Cap | LR3A, LR3B LW3A, LW3B LY3A, LY3B | PGJ18.5d-1 PGJ18.5d-24 PGJ18.5d-15 | in accordance with IEC Publication 60061 (sheet 7004-185-1) | |
| Electrical and photometric characteristics | | | | |
| Rated values | Volts | | 12 | |
| | | LR3A, LR3B | 3 | |
| | Watts | LW3A, LW3B LY3A, LY3B | 4 | |
| Objective Values ⁸ | Watts (at 13.5 V DC) | LR3A, LR3B | 3.5 max. | |
| | | LW3A, LW3B | 5 max. | |
| | | ¹² LY3A, LY3B | | |
| | Luminous flux (in lm at 13.5 V DC) | ⁵ LR3A, LR3B | 80 ± 20% ⁹ | 80 ± 10% ¹⁰ |
| | | ⁶ LW3A, LW3B | 250 ± 20% | 250 ± 10% ¹¹ |
| | | ^{7, 12} LY3A, LY3B | 150 ± 20% ⁹ | 150 ± 10% ¹⁰ |
| | Luminous flux (in lm at 9 V DC) | ⁵ LR3A, LR3B | 19 min | |
| ⁶ LW3A, LW3B | | 50 min. | | |
| ^{7, 12} LY3A, LY3B | | 30 min | | |

^{1/} The reference plane is the plane defined by the contact points of the cap-holder fit.

^{2/} The reference axis is perpendicular to the reference plane and passing through the centre of the bayonet core.

^{3/} Light emitting area: to be checked by means of the box system in Figure 2.

^{4/} A minimum free air space of 5mm around the light source shall be respected for convection.

^{5/} The emitted light shall be red.

^{6/} The emitted light shall be white.

^{7/} The emitted light shall be amber.

^{8/} After continuous operation for 30 minutes at 23 ± 2.5° C.

^{9/} The measured value shall be in between 100 per cent and 70 per cent of the value measured after 1 minute.

^{10/} The measured value shall be in between 85 per cent and 75 per cent of the value measured after 1 minute.

^{11/} The measured value shall be in between 100 per cent and 90 per cent of the value measured after 1 minute.

^{12/} Operated in flashing mode for 30 minutes (frequency = 1.5 Hz, duty cycle 50 per cent ON, 50 per cent OFF). Measured in the ON-state of flashing mode after 30 minutes of operation.

^{13/} Light centre length

Electrical characteristics

In case of LED light source failure (no light emitted) the max. electrical current draw, when operated between 12 V and 14 V, shall be less than 20 mA (open circuit condition).

Screen projection requirements

The following test is intended to define the requirements for the light emitting area of the LED light source and to determine whether the light emitting area is correctly positioned relative to the reference axis and reference plane in order to check compliance with the requirements.

The position of the light emitting area is checked by the box system defined in Figure 2, which is aligned to the planes C90 and C180 and shows the projection when viewing along direction $\gamma=0^\circ$ (C, γ as defined in Figure 3).

The proportion of the total luminous flux emitted into the viewing direction shall be as described in table 3.

Figure 2

Box definition of the light emitting area with dimensions as specified in table 2

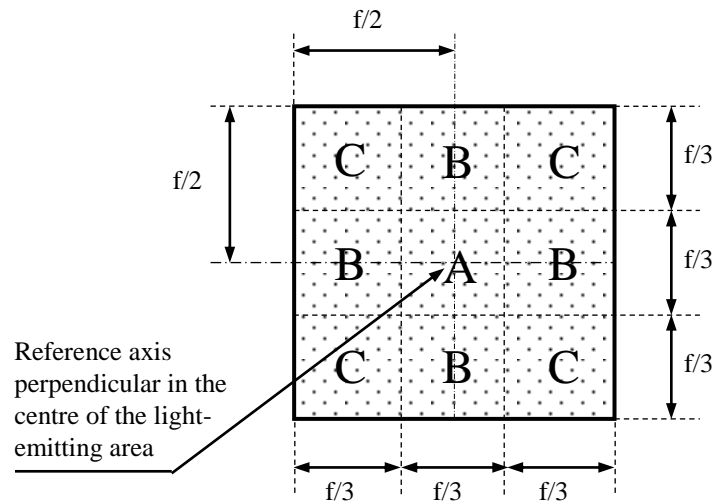

Table 2

Dimensions of the box system in Figure 2

| Dimensions in mm | f | |
|--|------------|-----------------------|
| | LR3A, LR3B | LW3A, LW3B LY3A, LY3B |
| LED light sources of normal production | 3.0 | 4.5 |
| Standard LED light sources | 3.0 | 4.5 |

Categories LR3A, LR3B, LW3A, LW3B, LY3A and LY3B

Sheet L3/4

Table 3

Proportion of the total luminous flux emitted into the viewing direction from the areas specified in figure 2

| <i>Category</i> | <i>Area(s)</i> | <i>LED light sources of normal production</i> | <i>Standard LED light sources</i> |
|-----------------|-----------------------------|---|-----------------------------------|
| LR3A LR3B | A | $\leq 25\%$ | $\leq 10\%$ |
| | Each B individually | $\geq 15\%$ | $\geq 20\%$ |
| | Each C individually | - | $\leq 10\%$ |
| | A, all B and all C together | $\geq 90\%$ | $\geq 90\%$ |
| LW3A LW3B | Each A,B individually | $\geq 6\%$ | $\geq 8\%$ |
| | Each A, B individually | $< 40\%$ | $< 30\%$ |
| LY3A LY3B | All A, B together | $\geq 55\%$ | $\geq 60\%$ |
| | Each C individually | $< 15\%$ | $< 10\%$ |
| | All A, B and C together | $\geq 90\%$ | $\geq 90\%$ |

Normalized luminous intensity distribution

The following test is intended to determine the normalized luminous intensity distribution of the light source in an arbitrary plane containing the reference axis. The intersection of the reference axis and the parallel plane to the reference plane in distance e is used as the coordinate system origin.

The light source is mounted on a flat plate with the corresponding mounting lug features. The plate is mounted to the goniometer table by a bracket, so that the reference axis of the light source lines up with one of the rotating axis of the goniometer. The corresponding measurement set-up is described in Figure 3.

Luminous intensity data is recorded with a standard photo-goniometer. The measurement distance should be chosen appropriately, to make sure that the detector is located in the far field of the light distribution.

The measurements shall be performed in C-planes C_0 (C_{180}) and C_{90} (C_{270}), which contain the reference axis of the light source. The test points for each plane for multiple polar angles γ are specified in Tables 4a and 4b.

The measured luminous intensity values, normalised to the measured luminous flux of the individual light source under test, shall be converted to normalised luminous intensity values of a 1,000 lm light source. The data shall comply with the tolerance band as defined in Tables 4a and 4b.

The drawings are intended only to illustrate the essential set-up for measurement of the LED light source.

Figure 3
Set-up to measure the luminous intensity distribution

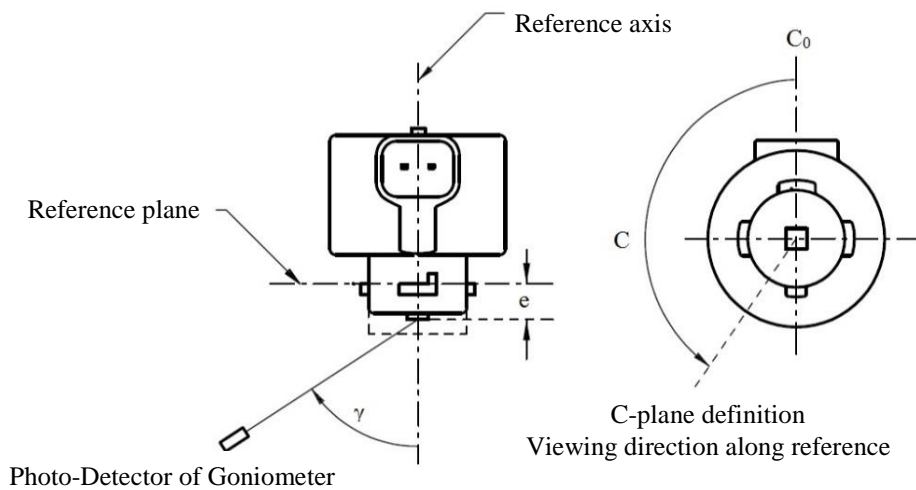

LR3A, LW3A, LY3A

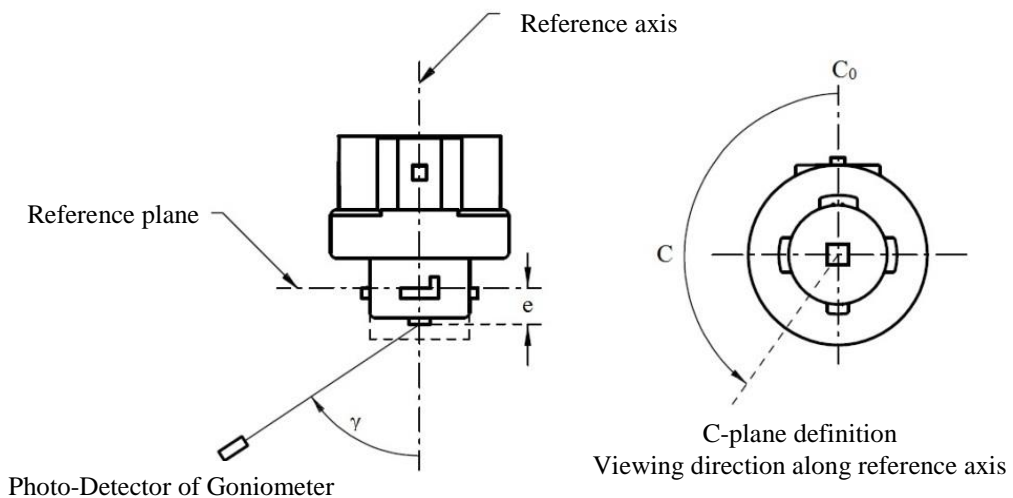

LR3B, LW3B, LY3B

Categories LR3A, LR3B, LW3A, LW3B, LY3A and LY3B

Sheet L3/6

The light pattern as described in Tables 4a and 4b shall be substantially uniform, i.e. in between two adjacent grid points the relative luminous intensity requirement is calculated by linear interpolation using the two adjacent grid points. In case of doubt this may be checked in addition to verification of the grid points given in Tables 4a and 4b.

Table 4a

Test point values of normalized intensities for categories LR3A and LR3B

| Angle γ | LED light sources of normal production | | Standard LED light sources | |
|----------------|--|------------------------------------|-------------------------------------|----------------------------------|
| | Minimum Intensity in cd /1000 lm | Maximum Intensity in cd/1000 lm | Minimum Intensity in cd /1000 lm | Maximum Intensity in cd /1000 lm |
| -90° | 0 | 38 | 0 | 25 |
| -75° | 0 | 160 | 0 | 140 |
| -60° | 98 | 246 | 127 | 220 |
| -45° | 142 | 305 | 181 | 275 |
| -30° | 169 | 352 | 213 | 315 |
| -15° | 192 | 389 | 239 | 340 |
| 0° | 200 | 401 | 248 | 352 |
| 15° | 192 | 389 | 239 | 340 |
| 30° | 169 | 352 | 213 | 315 |
| 45° | 142 | 305 | 181 | 275 |
| 60° | 98 | 246 | 127 | 220 |
| 75° | 0 | 160 | 0 | 140 |
| 90° | 0 | 38 | 0 | 25 |

Table 4b

Test point values of normalized intensities for categories LW3A, LW3B, LY3A and LY3B

| Angle γ | LED light sources of normal production | | Standard LED light sources | |
|----------------|--|------------------------------------|-------------------------------------|----------------------------------|
| | Minimum Intensity in cd /1000 lm | Maximum Intensity in cd/1000 lm | Minimum Intensity in cd /1000 lm | Maximum Intensity in cd /1000 lm |
| -90° | 0 | 70 | 0 | 65 |
| -75° | 0 | 160 | 0 | 150 |
| -60° | 85 | 245 | 105 | 220 |
| -45° | 145 | 310 | 180 | 275 |
| -30° | 170 | 380 | 220 | 335 |
| -15° | 190 | 415 | 240 | 370 |
| 0° | 200 | 425 | 250 | 390 |
| 15° | 190 | 415 | 240 | 370 |
| 30° | 170 | 380 | 220 | 335 |
| 45° | 145 | 310 | 180 | 275 |
| 60° | 85 | 245 | 105 | 220 |
| 75° | 0 | 160 | 0 | 150 |
| 90° | 0 | 70 | 0 | 65 |

The drawings are intended only to illustrate the essential dimensions of the LED light source.

Figure 1*

Main Drawing

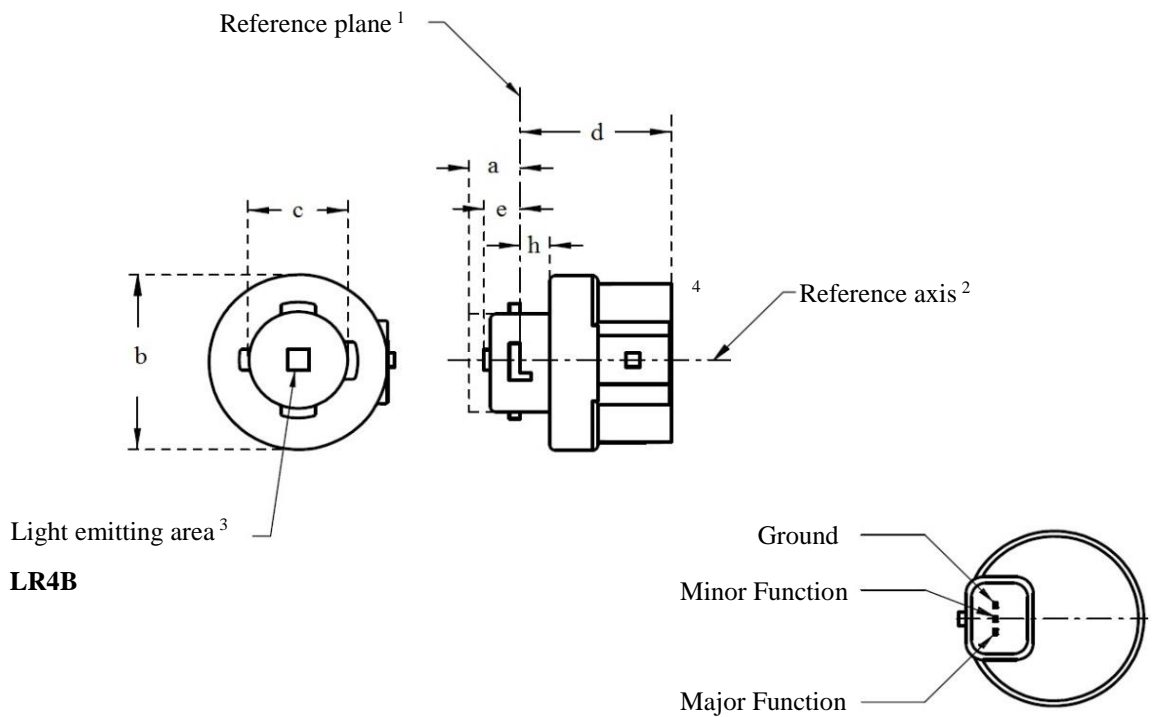
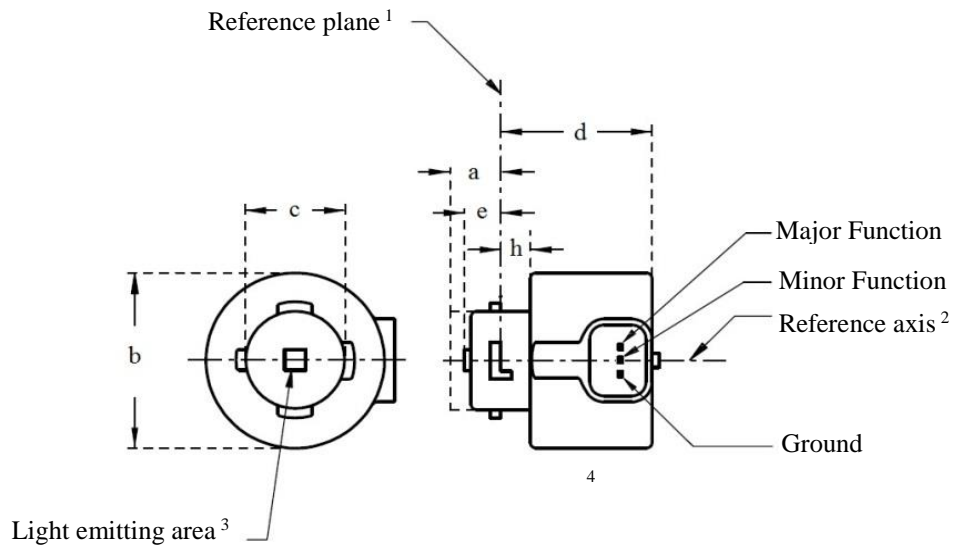

For the notes see sheet LR4/2.

* Projection method:

Categories LR4A and LR4B

Sheet LR4/2

Table 1
Essential dimensional, electrical and photometric characteristics of the LED light source

| Dimensions | | Production LED light sources | | Standard LED light sources | |
|--|------------------------------------|------------------------------|-----------------------|----------------------------|-----------------------|
| a | mm | 6.0 max. | | | |
| b | mm | c + 10.0 min. 38.0 max. | | | |
| c | mm | 18.5 ± 0.1 | | | |
| d | mm | 28.0 max. | | | |
| e ^{9/} | mm | 3.0 ± 0.30 | | 3.0 ± 0.15 | |
| h | mm | 5.5 + 0.0/ - 0.1 | | | |
| Cap PGJ18.5t-5 in accordance with IEC Publication 60061 (sheet 7004-185-1) | | | | | |
| Electrical and photometric characteristics ⁵ | | | | | |
| Rated values | | Minor function | Major function | Minor function | Major function |
| | Volts | 12 | | 12 | |
| | Watts | 0.75 | 3 | 0.75 | 3 |
| Objective Values ⁶ | Watts (at 13.5 V DC) | 1.0 max. | 3.5 max. | 1.0 max. | 3.5 max. |
| | Luminous flux (in lm at 13.5 V DC) | 6 ± 20% | 80 ± 20% ⁷ | 6 ± 10% | 80 ± 10% ⁸ |
| | Luminous flux (in lm at 9 V DC) | 1.5 min. | 19 min. | | |

^{1/} The reference plane is the plane defined by the contact points of the cap-holder fit.

^{2/} The reference axis is perpendicular to the reference plane and passing through the centre of the Bayonet core.

^{3/} Light emitting area: to be checked by means of the box system in Figure 2

^{4/} A minimum free air space of 5mm around the LED light source shall be respected for convection.

^{5/} The emitted light shall be red.

^{6/} After continuous operation for 30 minutes at 23 ± 2.5° C.

^{7/} The measured value shall be in between 100 per cent and 70 per cent of the value measured after 1 minute.

^{8/} The measured value shall be in between 85 per cent and 75 per cent of the value measured after 1 minute.

^{9/} Light centre length

Electrical characteristics

In case of LED light source failure (no light emitted) the max. electrical current draw, when operated between 12 V and 14 V, shall be less than 20 mA (open circuit condition).

The major and the minor function shall be operated by separate electrical circuits.

Screen projection requirements

The following test is intended to define the requirements for the light emitting area of the LED light source and to determine whether the light emitting area is correctly positioned relative to the reference axis and reference plane in order to check compliance with the requirements.

The position of the light emitting area is checked by the box system defined in Figure 2, which is aligned to the planes C90 and C180 and shows the projection when viewing along direction $\gamma=0^\circ$ (C, γ as defined in Figure 3).

The proportion of the total luminous flux emitted into the viewing direction shall be as described in table 3.

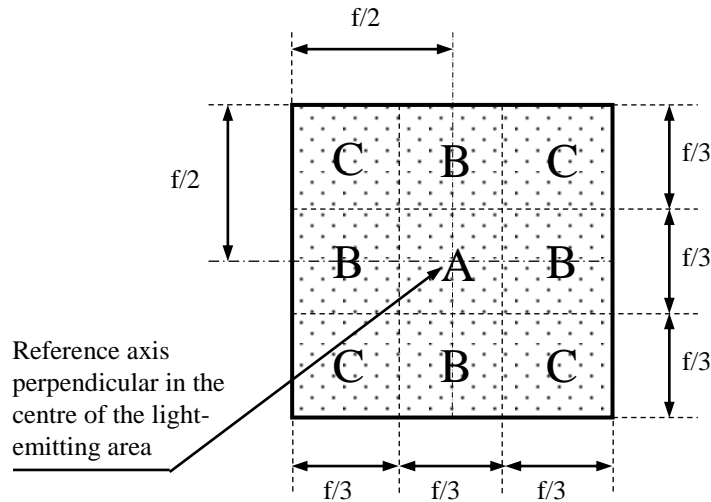

Figure 2

Box definition of the light emitting area with dimensions as specified in table 2

Table 2

Dimensions of the box system in Figure 2

| Dimensions in mm | f |
|--|-----|
| LED light sources of normal production | 4.5 |
| Standard LED light sources | 4.5 |

Table 3

Proportion of the total luminous flux emitted into the viewing direction from the areas specified in figure 2

| Function | Area(s) | LED light sources of normal production | Standard LED light sources |
|----------|-----------------------------|--|----------------------------|
| Minor | A | $\geq 75\%$ | $\geq 80\%$ |
| Major | A | $\leq 25\%$ | $\leq 10\%$ |
| | Each B individually | $\geq 15\%$ | $\geq 20\%$ |
| | Each C individually | - | $\leq 10\%$ |
| | A, all B and all C together | $\geq 90\%$ | $\geq 90\%$ |

Normalized luminous intensity distribution

The following test is intended to determine the normalized luminous intensity distribution of the light source in an arbitrary plane containing the reference axis. The intersection of the reference axis and the parallel plane to the reference plane in distance e is used as the coordinate system origin.

The light source is mounted on a flat plate with the corresponding mounting lug features. The plate is mounted to the goniometer table by a bracket, so that the reference axis of the light source lines up with one of the rotating axis of the goniometer. The corresponding measurement set-up is described in Figure 3.

Luminous intensity data is recorded with a standard photo-goniometer. The measurement distance should be chosen appropriately, to make sure that the detector is located in the far field of the light distribution.

The measurements shall be performed in C-planes C_0 (C_{180}) and C_{90} (C_{270}), which contain the reference axis of the light source. The test points for each plane for multiple polar angles γ are specified in Table 4.

After measurement the data shall be normalized to 1,000 lm according to paragraph 3.1.11 using the luminous flux of the individual light source under test. The data shall comply with the tolerance band as defined in Table 4.

The drawings are intended only to illustrate the essential set-up for measurement of the LED light source.

Figure 3*

Set-up to measure the luminous intensity distribution

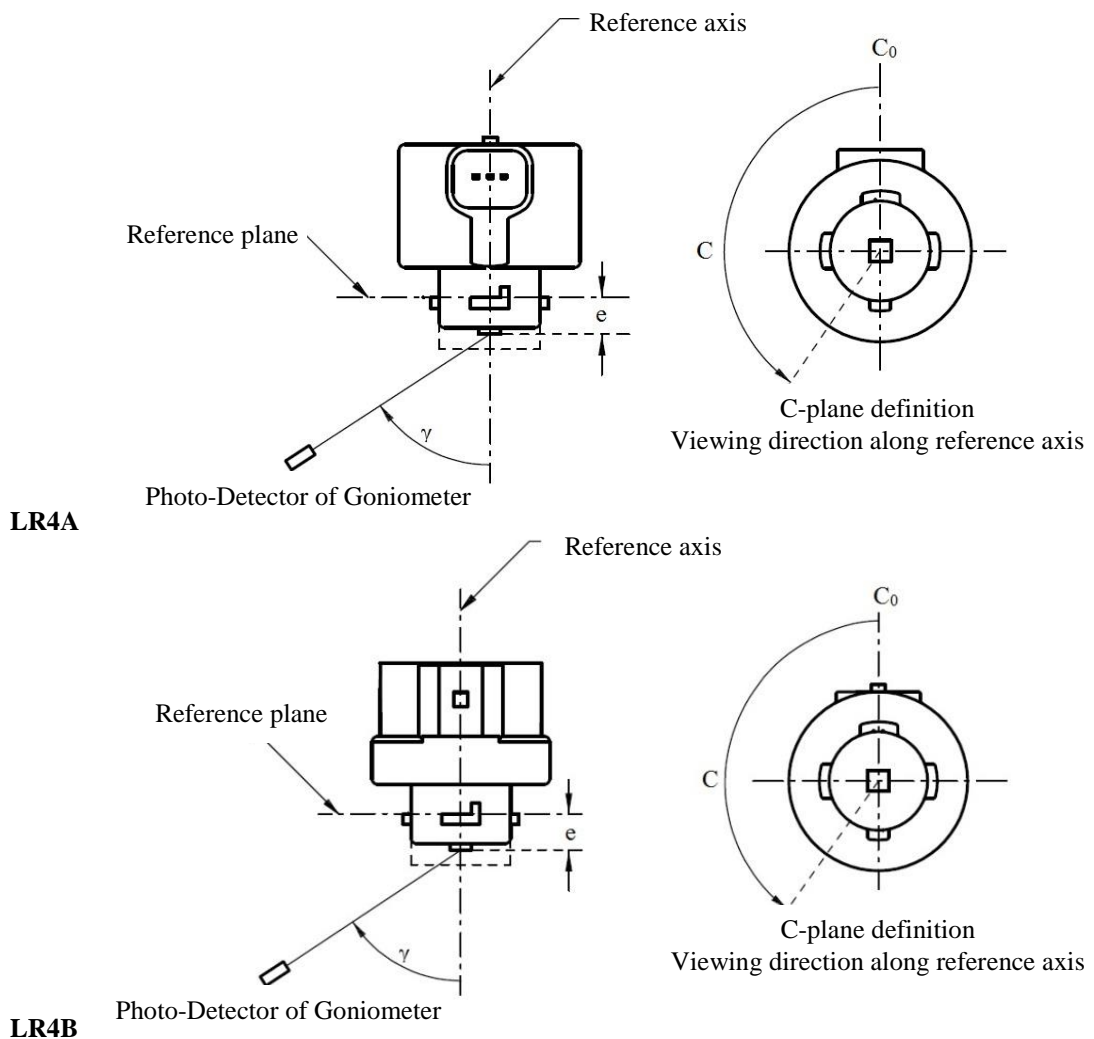

The light pattern as described in Table 4 shall be substantially uniform, i.e. in between two adjacent grid points the relative luminous intensity requirement is calculated by linear interpolation using the two adjacent grid points. In case of doubt this may be checked in addition to verification of the grid points given in Table 4.

Table 4

Test point values of normalized intensities of normal production and standard LED light sources, respectively. Requirements apply to both, major and minor function.

| Angle γ | LED light sources of normal production | | Standard LED light sources | |
|----------------|--|-----------------------------------|------------------------------------|-----------------------------------|
| | Minimum Intensity in cd /1000lm | Maximum Intensity in cd/1000lm | Minimum Intensity in cd /1000lm | Maximum Intensity in cd/1000lm |
| -90° | 0 | 38 | 0 | 25 |
| -75° | 0 | 160 | 0 | 140 |
| -60° | 98 | 246 | 127 | 220 |
| -45° | 142 | 305 | 181 | 275 |
| -30° | 169 | 352 | 213 | 315 |
| -15° | 192 | 389 | 239 | 340 |
| 0° | 200 | 401 | 248 | 352 |
| 15° | 192 | 389 | 239 | 340 |
| 30° | 169 | 352 | 213 | 315 |
| 45° | 142 | 305 | 181 | 275 |
| 60° | 98 | 246 | 127 | 220 |
| 75° | 0 | 160 | 0 | 140 |
| 90° | 0 | 38 | 0 | 25 |

Categories LR5A, LR5B, LW5A, LW5B, LY5A, LY5B

The drawings are intended only to illustrate the essential dimensions of the LED light source.

Figure 1*
Main Drawing

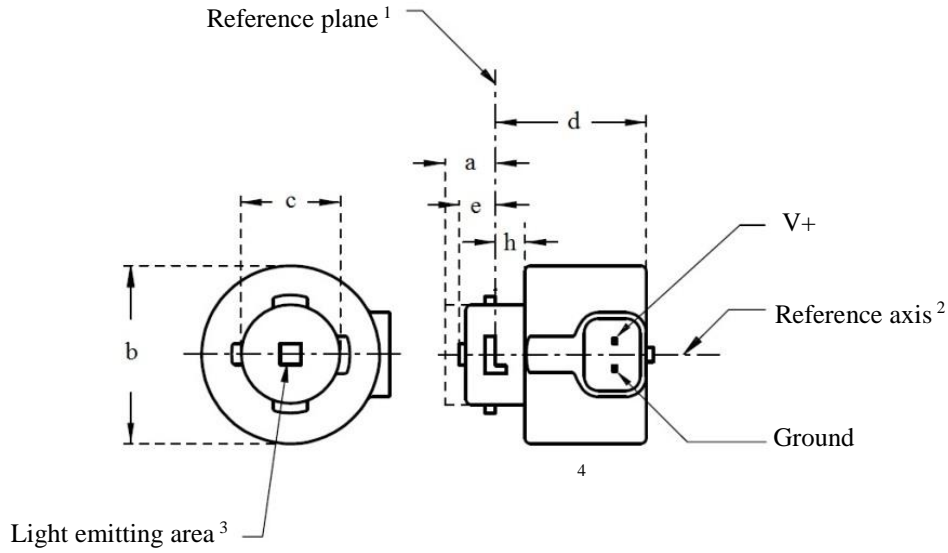

LR5A, LW5A, LY5A

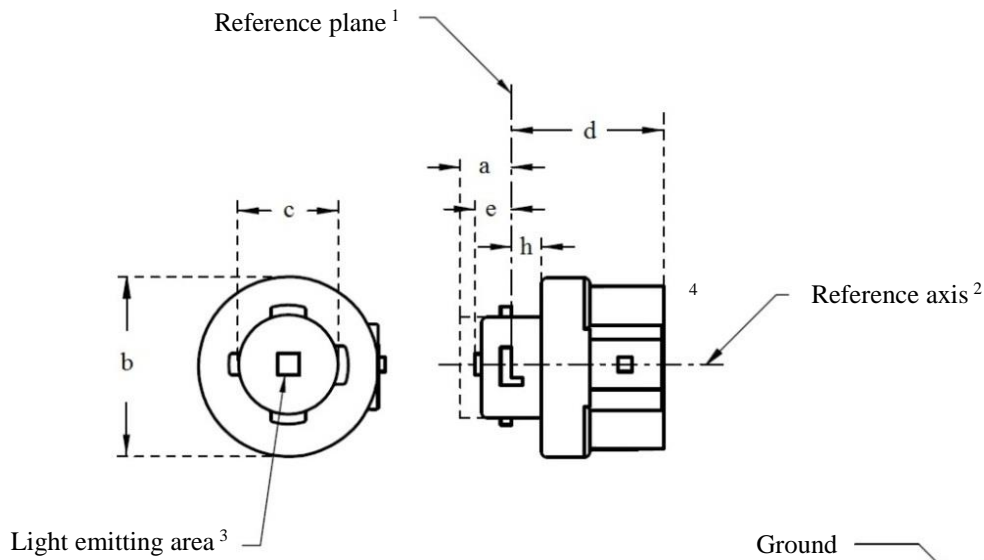

LR5B, LW5B, LY5B

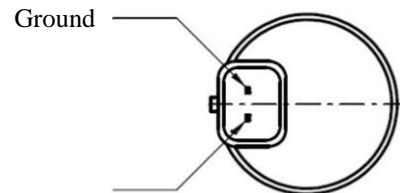

For the notes see sheet L5/2

* Projection method:

Table 1

Essential dimensional, electrical and photometric characteristics of the LED light source

| Dimensions | | Production LED light sources | Standard LED light sources | |
|---|--|---|---|------------------------|
| a | mm | 6.0 max. | | |
| b | mm | c + 10.0 min. 38.0 max. | | |
| c | mm | 18.5 ± 0.1 | | |
| d | mm | 28.0 max. | | |
| e ^{11/} | mm | 3.0 ± 0.30 | 3.0 ± 0.15 | |
| h | mm | 5.5 + 0.0/ - 0.1 | | |
| Cap | LR5A, LR5B LW5A, LW5B LY5A, LY5B | PGJ18.5d-10 PGJ18.5d-28 PGJ18.5d-19 | in accordance with IEC Publication 60061 (sheet 7004-185-1) | |
| <i>Electrical and photometric characteristics</i> | | | | |
| Rated values | Volts | | 12 | |
| | Watts | LR5A, LR5B | 3 | |
| | | LW5A, LW5B LY5A, LY5B | 6 | |
| Objective Values ⁸ | Watts (at 13.5 V DC) | LR5A, LR5B | 3.5 max. | |
| | | LW5A, LW5B | 8 max. | |
| | | ¹⁰ LY5A, LY5B | | |
| | Luminous flux (in lm at 13.5 V DC) | ⁵ LR5A, LR5B | 120 ± 15% | 120 ± 5% ⁹ |
| | | ⁶ LW5A, LW5B | 350 ± 20% | 350 ± 10% ⁹ |
| | | ^{7, 10} LY5A, LY5B | 280 ± 20% | 280 ± 10% ⁹ |
| | Luminous flux (in lm at 9 V DC) | ⁵ LR5A, LR5B | 28 min. | |
| | | ⁶ LW5A, LW5B | 65 min. | |
| | | ^{7, 10} LY5A, LY5B | 55 min. | |

^{1/} The reference plane is the plane defined by the contact points of the cap-holder fit.

^{2/} The reference axis is perpendicular to the reference plane and passing through the centre of the bayonet core.

^{3/} Light emitting area: to be checked by means of the box system in Figure 2

^{4/} A minimum free air space of 5mm around the light source shall be respected for convection.

^{5/} The emitted light shall be red.

^{6/} The emitted light shall be white.

^{7/} The emitted light shall be amber.

^{8/} After continuous operation for 30 minutes at 23 ± 2.5° C.

^{9/} The measured value shall be in between 100 per cent and 90 per cent of the value measured after 1 minute.

^{10/} Operated in flashing mode for 30 minutes (frequency = 1.5 Hz, duty cycle 50 per cent ON, 50 per cent OFF). Measured in the ON-state of flashing mode after 30 minutes of operation.

^{11/} Light centre length

Electrical characteristics

In case of LED light source failure (no light emitted) the max. electrical current draw, when operated between 12 V and 14 V, shall be less than 20 mA (open circuit condition).

Screen projection requirements

The following test is intended to define the requirements for the light emitting area of the LED light source and to determine whether the light emitting area is correctly positioned relative to the reference axis and reference plane in order to check compliance with the requirements.

The position of the light emitting area is checked by the box system defined in Figure 2, which is aligned to the planes C90 and C180 and shows the projection when viewing along direction $\gamma=0^\circ$ (C, γ as defined in Figure 3).

The proportion of the total luminous flux emitted into the viewing direction shall be as described in table 3.

Figure 2
Box definition of the light emitting area with dimensions as specified in table 2

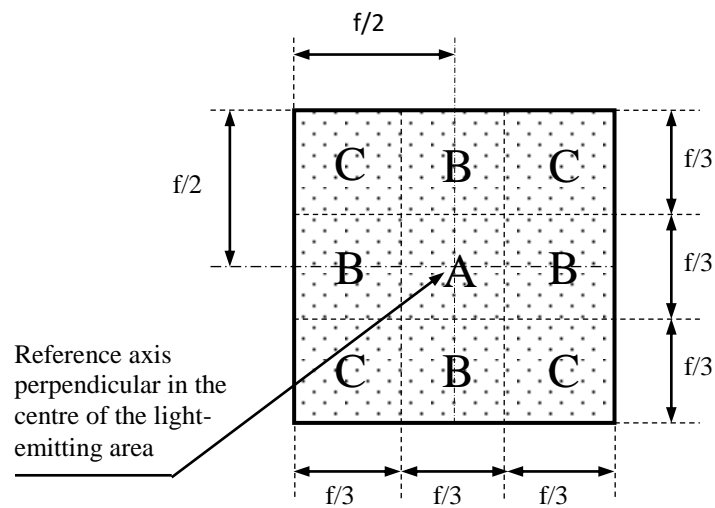

Table 2
Dimensions of the box system in Figure 2

| <i>Dimensions in mm</i> | <i>f</i> |
|--|----------|
| LED light sources of normal production | 4.5 |
| Standard LED light sources | 4.5 |

Table 3
Proportion of the total luminous flux emitted into the viewing direction from the areas specified in figure 2

| <i>Category</i> | <i>Area(s)</i> | <i>LED light sources of normal production</i> | <i>Standard LED light sources</i> |
|----------------------------------|-------------------------|---|-----------------------------------|
| LR5A LR5B | Each B individually | $\geq 10\%$ | $\geq 15\%$ |
| | Each A, B individually | $< 40\%$ | $< 30\%$ |
| | All B together | $\geq 60\%$ | $\geq 65\%$ |
| | Each C individually | - | $< 10\%$ |
| | All A, B and C together | $\geq 90\%$ | $\geq 90\%$ |
| LW5A LW5B LY5A LY5B | Each A,B individually | $\geq 6\%$ | $\geq 8\%$ |
| | Each A, B individually | $< 40\%$ | $< 30\%$ |
| | All A, B together | $\geq 55\%$ | $\geq 60\%$ |
| | Each C individually | $< 15\%$ | $< 10\%$ |
| | All A, B and C together | $\geq 90\%$ | $\geq 90\%$ |

Normalized luminous intensity distribution

The following test is intended to determine the normalized luminous intensity distribution of the light source in an arbitrary plane containing the reference axis. The intersection of the reference axis and the parallel plane to the reference plane in distance e is used as the coordinate system origin.

The light source is mounted on a flat plate with the corresponding mounting lug features. The plate is mounted to the goniometer table by a bracket, so that the reference axis of the light source lines up with one of the rotating axis of the goniometer. The corresponding measurement set-up is described in Figure 3.

Luminous intensity data is recorded with a standard photo-goniometer. The measurement distance should be chosen appropriately, to make sure that the detector is located in the far field of the light distribution.

The measurements shall be performed in C-planes C_0 (C_{180}) and C_{90} (C_{270}), which contain the reference axis of the light source. The test points for each plane for multiple polar angles γ are specified in Table 4.

The measured luminous intensity values, normalised to the measured luminous flux of the individual light source under test, shall be converted to normalised luminous intensity values of a 1,000 lm light source. The data shall comply with the tolerance band as defined in Table 4.

The drawings are intended only to illustrate the essential set-up for measurement of the LED light source.

Figure 3
Set-up to measure the luminous intensity distribution

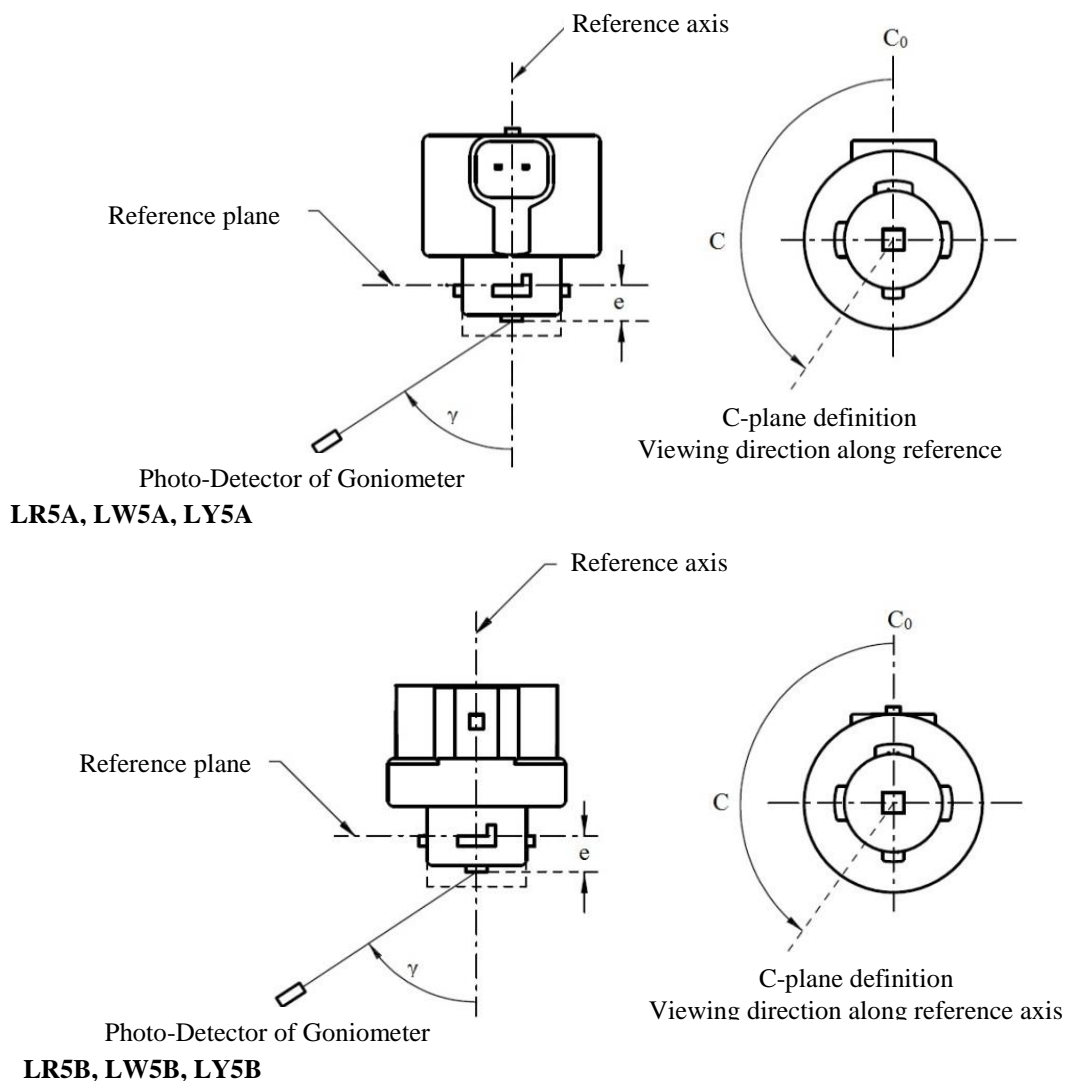

The light pattern as described in Table 4 shall be substantially uniform, i.e. in between two adjacent grid points the relative luminous intensity requirement is calculated by linear interpolation using the two adjacent grid points. In case of doubt this may be checked in addition to verification of the grid points given in Table 4.

Table 4

Test point values of normalized intensities for categories LR5A, LR5B, LW5A, LW5B, LY5A and LY5B

| Angle γ | <i>LED light sources of normal production</i> | | <i>Standard LED light sources</i> | |
|----------------|---|--|---|---|
| | <i>Minimum Intensity in cd /1000 lm</i> | <i>Maximum Intensity in cd/1000 lm</i> | <i>Minimum Intensity in cd /1000 lm</i> | <i>Maximum Intensity in cd /1000 lm</i> |
| -90° | 0 | 70 | 0 | 65 |
| -75° | 0 | 160 | 0 | 150 |
| -60° | 85 | 245 | 105 | 220 |
| -45° | 145 | 310 | 180 | 275 |
| -30° | 170 | 380 | 220 | 335 |
| -15° | 190 | 415 | 240 | 370 |
| 0° | 200 | 425 | 250 | 390 |
| 15° | 190 | 415 | 240 | 370 |
| 30° | 170 | 380 | 220 | 335 |
| 45° | 145 | 310 | 180 | 275 |
| 60° | 85 | 245 | 105 | 220 |
| 75° | 0 | 160 | 0 | 150 |
| 90° | 0 | 70 | 0 | 65 |