

**Proposal for amendments to UN Regulation No. 43,
document ECE/TRANS/WP.29/GRSG/2015/22 (Safety glazing)**

The aim of this proposal is to specify in details the parameters of the abrasion test machine.

Proposal

Annex 3, Figure 4, shall be replaced by this diagram with dimensions:

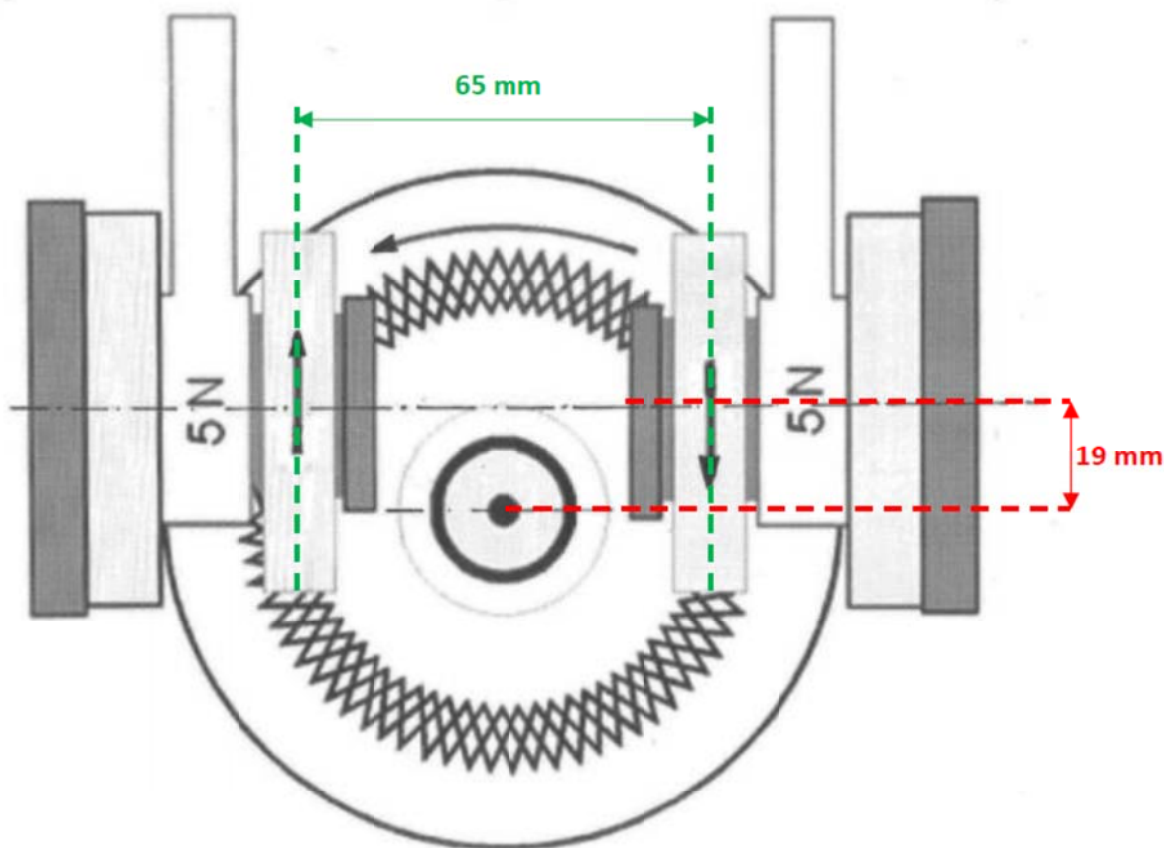

Justification

In order to avoid any confusion with reference to the document ECE/TRANS/WP.29/GRSG/2015/22 submitted by Hungary, we propose to replace the diagram of abrading instrument by the diagram that shares the distance clearly between the symmetry planes of the wheels (65 mm) and the offset of the wheel axis from the turntable axis (19 mm) which shall be measured.