

**Economic and Social Council**Distr.: General
2 February 2018

Original: English

Economic Commission for Europe**Inland Transport Committee****World Forum for Harmonization of Vehicle Regulations****Working Party on Lighting and Light-Signalling****Seventy-ninth session**

Geneva, 24-27 April 2018

Item 7 (a) of the provisional agenda

Other Regulations:**Regulation No. 10 (Electromagnetic compatibility)****Proposal for the 06 series of amendments to Regulation
No. 10 (Electromagnetic compatibility)****Submitted by the Task Force on Electromagnetic Compatibility (TF
EMC)***

The text reproduced below was prepared by TF EMC with the aim to make Regulation No. 10 consistent with the International Special Committee on Radio Interference (CISPR) 12 Standard vehicle narrow-band limit and the last CISPR 12 set-ups (artificial networks, harness location, Z-folding, ...) for vehicles in charging mode. It also includes precision for vehicle in charging mode operating conditions (alternative or direct current charging). The modifications are marked in bold for new or strikethrough for deleted characters.

* In accordance with the programme of work of the Inland Transport Committee for 2014–2018 (ECE/TRANS/240, para. 105 and ECE/TRANS/2014/26, cluster 02.4), the World Forum will develop, harmonize and update UN Regulations in order to enhance the performance of vehicles. The present document is submitted in conformity with that mandate.

GE.18-01552(E)



* 1 8 0 1 5 5 2 *

Please recycle The recycling symbol, consisting of three chasing arrows forming a triangle.



I. Proposal

Paragraph 3.1.9., to be deleted:

~~“3.1.9. Vehicle type approval shall be applied for both REESS and coupling system for charging the REESS as they are considered as electrical/electronic systems.”~~

Paragraph 6.3.2.1., amend to read:

“6.3.2.1. If measurements are made using the method described in Annex 5 using a vehicle-to-antenna spacing of 10.0 ± 0.2 m, the limits shall be ~~22 dB microvolts/m in the 30 to 75 MHz frequency band and 22 to 33 dB microvolts/m in the 75 to 400 MHz frequency band, this limit increasing logarithmically with frequencies above 75 MHz as shown in Appendix 4 to this Regulation. In the 400 to 1,000 MHz frequency band the limit remains constant at 33 dB microvolts/m.~~ **28 dB microvolts/m in the 30 to 230 MHz frequency band and 35 dB microvolts/m in the 230 to 1,000 MHz frequency band.**”

Paragraph 6.3.2.2., amend to read:

“6.3.2.2. If measurements are made using the method described in Annex 5 using a vehicle-to-antenna spacing of 3.0 ± 0.05 m, the limit shall be ~~32 dB microvolts/m in the 30 to 75 MHz frequency band and 32 to 43 dB microvolts/m in the 75 to 400 MHz frequency band, this limit increasing logarithmically with frequencies above 75 MHz as shown in Appendix 5 to this Regulation. In the 400 to 1,000 MHz frequency band the limit remains constant at 43 dB microvolts/m.~~ **38 dB microvolts/m in the 30 to 230 MHz frequency band and 45 dB microvolts/m in the 230 to 1,000 MHz frequency band.**”

Paragraph 7.1.4., amend to read:

“7.1.4. Artificial networks

AC Power mains shall be applied to the vehicle / ESA through $50 \mu\text{H}/50 \Omega$ AN(s) AMN(s) as defined in CISPR 16-1-2 paragraph 4.3.

DC Power mains shall be applied to the vehicle / ESA through $5 \mu\text{H}/50 \Omega$ **HVDC-charging-AN(s)** as defined in **CISPR-25 Appendix 8.**

High voltage power line shall be applied to the ESA through a $5 \mu\text{H}/50 \Omega$ HV-AN(s) as defined in Appendix 8.”

Paragraph 7.4.2.1., amend to read:

“7.4.2.1. If measurements are made using the method described in Annex 12, the limits for rated current ≤ 16 A per phase and not subjected to conditional connection are those defined in IEC 61000-3-3, paragraph 5-:

- **the value of Pst shall not be greater than 1.0;**
- **the value of Plt shall not be greater than 0.65;**
- **the value of d(t) during a voltage change shall not exceed 3.3 per cent for more than 500 ms;**
- **the relative steady-state voltage change, dc, shall not exceed 3.3 per cent;**
- **the maximum relative voltage change dmax, shall not exceed 6 per cent.**”

Paragraph 7.4.2.2., amend to read:

- “7.4.2.2. If measurements are made using the method described in Annex 12, the limits for rated current > 16 A and ≤ 75 A per phase and subjected to conditional connection are those defined in IEC 61000-3-11, paragraph 5.:
- **the value of Pst shall not be greater than 1.0;**
 - **the value of Plt shall not be greater than 0.65;**
 - **the value of d(t) during a voltage change shall not exceed 3.3 per cent for more than 500 ms;**
 - **the relative steady-state voltage change, dc, shall not exceed 3.3 per cent;**
 - **the maximum relative voltage change dmax, shall not exceed 6 per cent.”**

Paragraph 7.19.1., table 18, amend to read:

“Table 18

Immunity of ESA

Test pulse number	Immunity test level	Functional status for systems:	
		Related to immunity related functions	Not related to immunity related functions
1	III	C	D
2a	III	B	D
2b	III	C	D
3a/3b	III	A	D
4	III	B (for ESA which shall be operational during engine start phases) C (for other ESA)	D

”

Paragraph 7.20.4., amend to read:

- “7.20.4. Vehicles and / or ESA which are intended to be used in "REESS charging mode coupled to the power grid" in the configuration connected to a DC-charging station with a length of a DC network cable (**cable between the DC charging station and the vehicle plug**) shorter than 30 m do not have to fulfil the requirements of ~~Annex 13, Annex 15, Annex 16, Annex 19, Annex 21 and Annex 22.~~ **paragraphs 7.5., 7.8., 7.9., 7.13., 7.15., 7.16.”**

Paragraph 7.20.5., amend to read:

- “7.20.5. Vehicles and/or ESA which are intended to be used in "REESS charging mode coupled to the power grid" in the configuration connected to a local/private DC-charging station without additional participants do not have to fulfil requirements of ~~Annex 13, Annex 15, Annex 16, Annex 19, Annex 21 and Annex 22.~~ **paragraphs 7.5., 7.8., 7.9., 7.13., 7.15., 7.16.”**

Paragraphs 13.1. to 13.11., amend to read:

- ~~“13.1. As from the official date of entry into force of the 03-series of amendments, no Contracting Party applying this Regulation shall refuse to grant approval under this Regulation as amended by the 03-series of amendments.~~
- ~~13.2. As from 12 months after the date of entry into force of this Regulation, as amended by the 03-series of amendments, Contracting Parties applying this~~

~~Regulation shall grant approvals only if the vehicle type, component or separate technical unit to be approved meets the requirements of this Regulation as amended by the 03 series of amendments.~~

- ~~13.3. Contracting Parties applying this Regulation shall not refuse to grant extensions of approval to the preceding series of amendments to this Regulation.~~
- ~~13.4. Starting 48 months after the entry into force of the 03 series of amendments to this Regulation, Contracting Parties applying this Regulation may refuse first national registration (first entry into service) of a vehicle, component or separate technical unit which does not meet the requirements of the 03 series of amendments to this Regulation.~~
- ~~13.5. As from the official date of entry into force of the 04 series of amendments, no Contracting Party applying this Regulation shall refuse to grant type approvals under this Regulation as amended by the 04 series of amendments.~~
- ~~13.6. As from 36 months after the official date of entry into force of this Regulation, as amended by the 04 series of amendments, Contracting Parties applying this Regulation shall grant approvals only if the vehicle type, component or separate technical unit, to be approved meets the requirements of this Regulation as amended by the 04 series of amendments.~~
- ~~13.7. Contracting Parties applying this Regulation shall continue to grant approvals to those types of vehicles or component or separate technical unit type which comply with the requirements of this Regulation as amended by the preceding series of amendments during the 36 months period which follows the date of entry into force of the 04 series of amendments.~~
- ~~13.8. Until 60 months after the date of entry into force of the 04 series of amendments, no Contracting Parties shall refuse national or regional type approval of a vehicle, component or separate technical unit type approved to the preceding series of amendments to this Regulation.~~
- ~~13.9. As from 60 months after the date of entry into force of the 04 series of amendments, Contracting Parties applying this Regulation may refuse national or regional type approval and may refuse first registration of a vehicle type, or first entry into service of component or separate technical unit which does not meet the requirements of the 04 series of amendments to this Regulation.~~
- ~~13.10. Notwithstanding paragraphs 13.8. and 13.9. above, approvals granted to the preceding series of amendments to the Regulation for vehicle type which are not equipped with a coupling system to charge the REESS, or for component or separate technical unit which doesn't include a coupling part to charge the REESS, shall remain valid and Contracting Parties applying this Regulation shall continue to accept them.~~
- ~~13.11. As from 36 months after the date of entry into force of the 05 series of amendments, Contracting Parties applying this Regulation shall grant type approvals only if the vehicle type, component or separate technical unit, to be approved meets the requirements of this Regulation as amended by the 05 series of amendments.~~

13.1. Transitional provisions applicable to 05 series of amendments

- 13.1.1. As from 09 October 2014, no Contracting Party applying this UN Regulation shall refuse to grant or refuse to accept UN type-approvals under this UN Regulation as amended by the 05 series of amendments.**

- 13.1.2. As from [9 October 2017], Contracting Parties applying this UN Regulation shall not be obliged to accept UN type-approvals to the preceding series of amendments, first issued after [9 October 2017].
- 13.1.3. Contracting Parties applying this UN Regulation shall not refuse to grant extensions of UN type-approvals, the latter first issued before [9 October 2017], for existing types which have been granted according to any series preceding 05 series of amendments to this UN Regulation.
- 13.1.4. Notwithstanding paragraph 13.1.2. and 13.1.3., Contracting Parties applying the UN Regulation shall continue to accept UN type-approvals issued according to the preceding series of amendments to the UN Regulation, for the vehicle type which are not equipped with a coupling system to charge the REESS, or for component or separate technical unit which doesn't include a coupling part to charge the REESS which are not affected by the changes introduced by the 05 series of amendments
- 13.1.5. Contracting Parties applying this UN Regulation shall not refuse to grant UN type-approvals according to any preceding series of amendments to this UN Regulation or extensions thereof.
- 13.2. Transitional provisions applicable to the 06 series of amendments
- 13.2.1. As from the official date of entry into force of the 06 series of amendments, no Contracting Party applying this UN Regulation shall refuse to grant or refuse to accept UN type-approvals under this UN Regulation as amended by the 06 series of amendments.
- 13.2.2. As from [1 September 2022], Contracting Parties applying this UN Regulation shall not be obliged to accept UN type-approvals to the preceding series of amendments, first issued after [1 September 2022].
- 13.2.3. Contracting Parties applying this UN Regulation shall not refuse to grant extensions of UN type-approvals, the latter first issued before [1 September 2022], for existing types which have been granted according to any series preceding 06 series of amendments to this UN Regulation.
- 13.2.4. Contracting Parties applying this UN Regulation shall not refuse to grant UN type-approvals according to any preceding series of amendments to this UN Regulation or extensions thereof.”

Appendix 1,

Paragraph 4., delete.

Paragraph 7., amend to read:

7. ISO 11451 "Road vehicles - Electrical disturbances by narrowband radiated electromagnetic energy - Vehicle test methods":
- Part 1: General and definitions (ISO 11451-1, third edition 2005 and Amd1: 2008);
- Part 2: Off-vehicle radiation source (ISO 11451-2, ~~third edition 2005~~ **fourth edition 2015**);
- Part 4: Bulk current injection (BCI) (ISO 11451-4, ~~first edition 1995~~ **third edition 2013**).

Paragraph 8., amend to read:

- “8. ISO 11452 "Road vehicles - Electrical disturbances by narrowband radiated electromagnetic energy - Component test methods":

- Part 1: General and definitions (ISO 11452-1, third edition 2005 and Amd1: 2008);
- Part 2: Absorber-lined chamber (ISO 11452-2, second edition 2004);
- Part 3: Transverse electromagnetic mode (TEM) cell (ISO 11452-3, third edition ~~2004~~ **2016**);
- Part 4: Bulk current injection (BCI) (ISO 11452-4, ~~third edition 2005 and Corrigendum 1:2009~~ **fourth edition 2011**);
- Part 5: Stripline (ISO 11452-5, second edition 2002).”

Paragraph 16., delete.

Paragraphs 17. to 19., renumber as 16. to 18., respectively.

Paragraph 20., renumber as 19. and amend to read:

~~20.~~**19.** CISPR 16-1-2 "Specification for radio disturbance and immunity measuring apparatus and methods - Part 1-2: Radio disturbance and immunity measuring apparatus - Ancillary equipment - Conducted disturbances", ~~edition 1.2: 2006~~ **edition 2 2014**.

Appendix 4,

Table, amend to read:

“

<i>Limit E (dBμV/m) at frequency F (MHz)</i>	
30-230 MHz	230-1,000 MHz
E = 28	E = 35

”

Figure, amend to read:

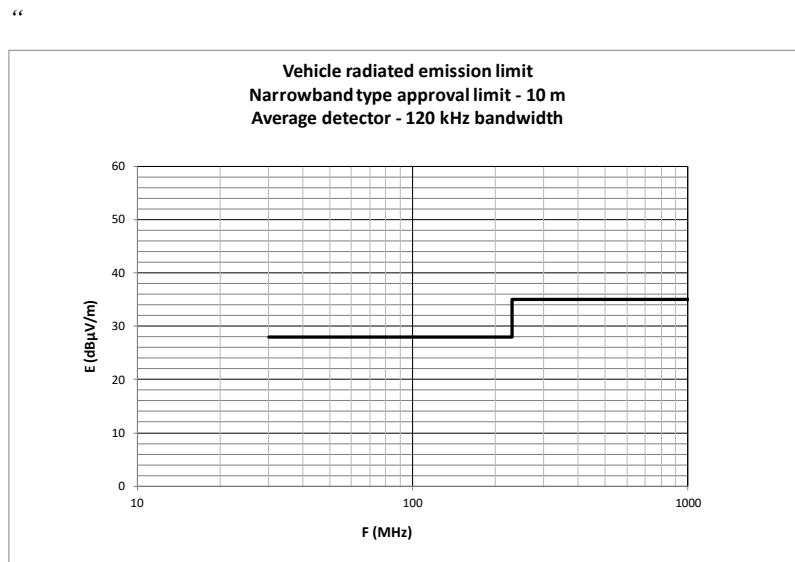

Appendix 5,

Table, amend to read:

“

<i>Limit E (dBμV/m) at frequency F (MHz)</i>	
30-230 MHz	230-1,000 MHz
E = 38	E = 45

”

Figure, amend to read:

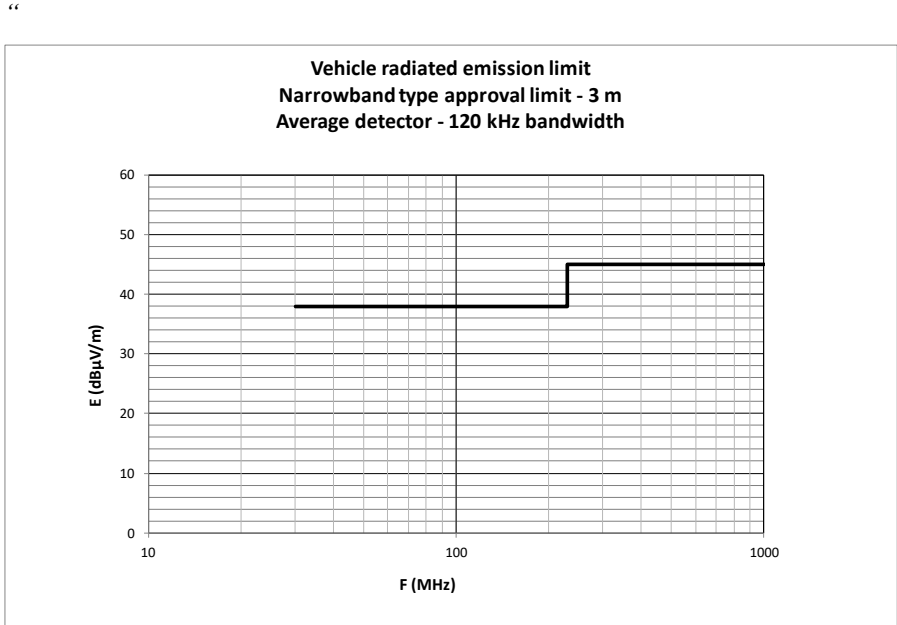

Frequency - megahertz - logarithmic
(See paragraph 6.3.2.2. of this Regulation)”

Appendix 8, amend to read:

“Appendix 8

HV artificial network

Figure 1
HV-AN artificial network

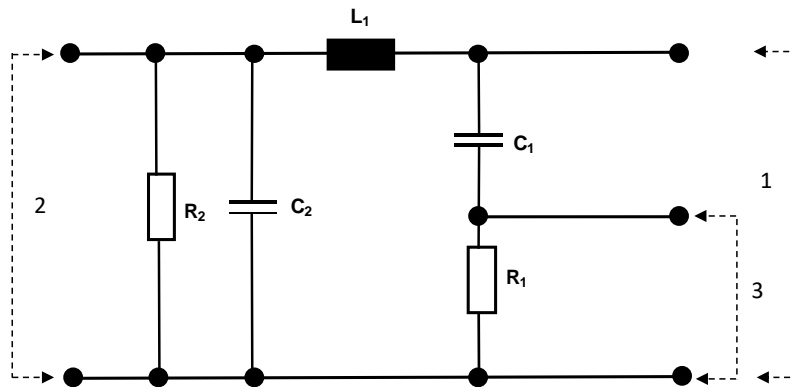

Key

- 1 Port for ESA
- 2 DC power supply port
- 3 Measurement port
- L_1 5 μH
- C_1 0.1 μF
- C_2 0.1 μF (default value)
- R_1 1 $\text{k}\Omega$
- R_2 1 $\text{M}\Omega$ (discharging C_2 to $< 50 \text{ V}_{\text{dc}}$ within 60 s)

Figure 2
Impedance of HV-AN artificial network

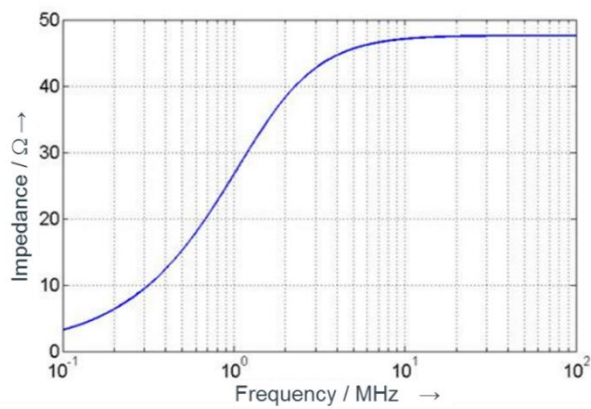
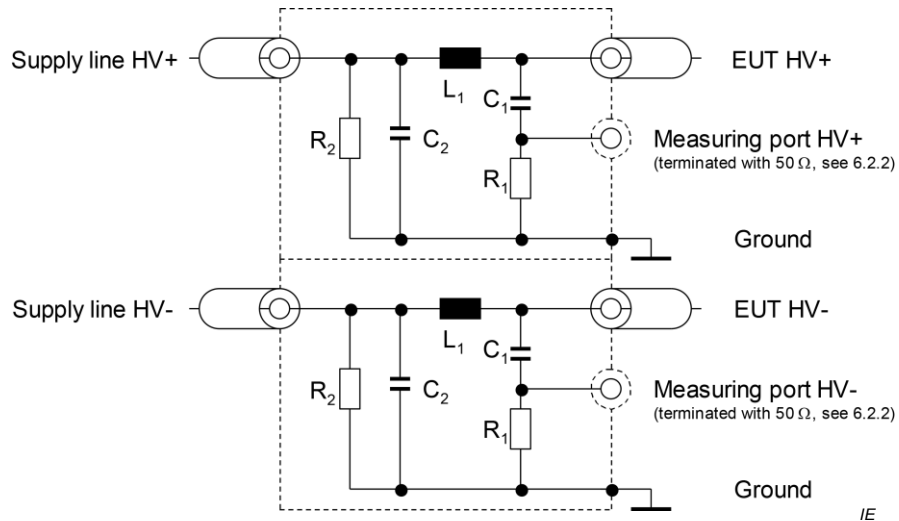

Figure 3
Combination of HV-AN artificial network

If unshielded HV ANs are used in a single shielded box, then there shall be an inner shield between the HV ANs as described in 3.



Key

L_1 : 5 μ H

C_1 : 0,1 μ F

C_2 : 0,1 μ F (default value)

R_1 : 1 k Ω

R_2 : 1 M Ω (discharging C_2 to < 50 V_{dc} within 60 s)

Figure 4
DC charging-AN

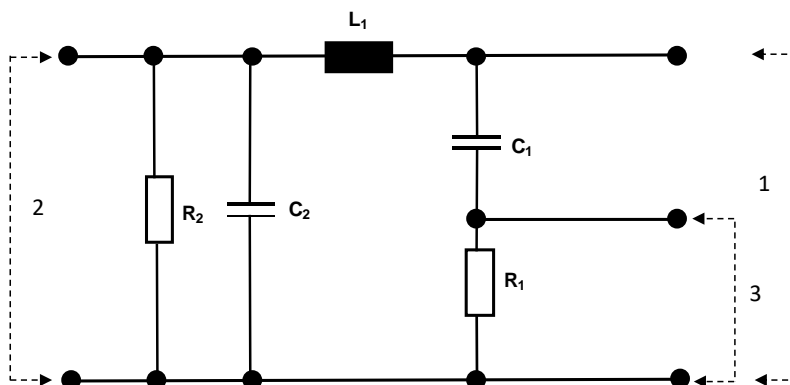

Key

1 Port for Vehicle / ESA

2 DC power supply port

3 Measurement port

- L_1 5 μH
 C_1 0,1 μF
 C_2 1 μF (default value)
 R_1 1 $\text{k}\Omega$
 R_2 1 $\text{M}\Omega$ (discharging C_2 to $< 50 \text{ V}_{\text{dc}}$ within 60 s)

Figure 5
Impedance of DC-charging-AN

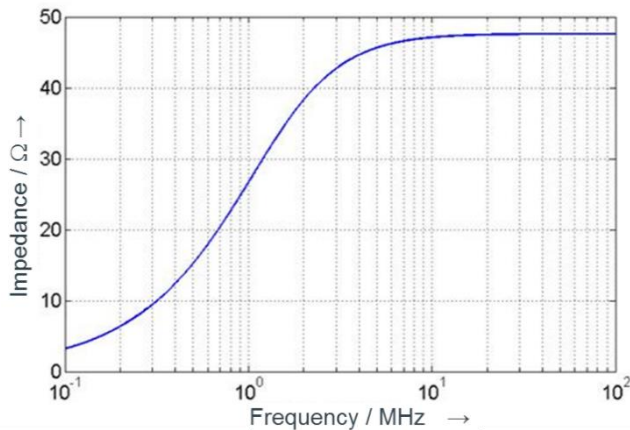

”

Annex 4,

Paragraph 2.2., amend to read:

“2.2. Vehicle in configuration "REESS charging mode coupled to the power grid".

The state of charge (SOC) of the traction battery shall be kept between 20 per cent and 80 per cent of the maximum SOC during the whole frequency range measurement (this may lead to splitting the measurement into different sub-bands with the need to discharge the vehicle's traction battery before starting the next sub-bands). ~~If the current consumption can be adjusted, then the current shall be set to at least 80 per cent of its nominal value.~~

If the current consumption can be adjusted, then the current shall be set to at least 80 per cent of its nominal value for AC charging.

If the current consumption can be adjusted, then the current shall be set to at least 80 per cent of its nominal value for DC charging unless another value is agreed with the type approval authorities.

In case of multiple batteries, the average state of charge must be considered.

The vehicle shall be immobilized, the engine(s) (ICE and/or electrical engine) shall be OFF and in charging mode. All other equipment which can be switched ON by the driver or passengers shall be OFF.

The test set-up for the connection of the vehicle in configuration "REESS charging mode coupled to the power grid" is shown in Figures 3a to 3h (depending of AC or DC power charging mode, location of charging plug and charging with or without communication) of Appendix 1 to this annex.”

Paragraph 2.3., amend to read:

“2.3. Charging station / Power mains

The charging station may be placed either in the test location or outside the test location.

Note 1: If the communication between the vehicle and the charging station could be simulated, the charging station may be replaced by the supply from power mains.

In both case, duplicated power mains and communication lines socket(s) shall be placed in the test location with the following conditions:

- (a) It shall be placed on the ground plane.
- (b) The length of the harness between the power mains/communication lines socket and the ~~AN(s)~~ **AMN(s)/DC-charging-AN(s)/IS(s)** shall be kept as short as possible **but not necessarily aligned with the charging cable.**
- (c) The harness between the power mains/communication lines socket and the ~~AN(s)~~ **AMN(s)/DC-charging-AN(s)/IS(s)** shall be placed as close as possible to the ground plane.

Note 2: The power mains and communication lines socket(s) should be filtered.

If the charging station is placed inside the test location then the harness between charging station and the power mains / communication lines socket shall be placed with the following conditions:

- (a) The harness on charging station side shall hang vertically down to the ground plane.”
- (b) The ~~extraneous~~ **excess** length shall be placed as close as possible to the ground plane and "Z-folded" if necessary.

Note 3: The charging station should be placed outside the beam width of the receiving antenna.”

Paragraph 2.4., amend to read:

“2.4. Artificial networks

The ~~AN(s)~~ **AMN(s)/DC-charging-AN(s)** shall be mounted directly on the ground plane. The cases of the ~~AN(s)~~ **AMN(s)/DC-charging-AN(s)** shall be bonded to the ground plane.

The measuring port of each ~~AN~~ **AMN/DC-charging-AN** shall be terminated with a 50 Ω load.

The ~~AN~~ **AMN(s)/DC-charging-AN(s)** shall be placed as defined in Figures 3a to 3h.”

Paragraph 2.6., amend to read:

“2.6. Power charging / communication cable

The power charging / communication cable shall be placed in a straight line between the ~~AN(s)~~ **AMN(s)/DC-charging-AN(s)/IS(s)** and the vehicle charging plug. The projected cable length shall be 0.8 m (+0.2/-0 m).

If the length of the cable is longer than 1 m, the ~~extraneous~~ **excess** length shall be "Z-folded" **with a width of** ~~in~~ **less than 0.5 m** ~~width~~, **and the “Z-**

folded” portion should be placed approximately around the middle of the distance between the AMN/DC-charging-AN and the vehicle.

If it is impractical to do so because of cable bulk or stiffness, or because the testing is being done at a user installation, the disposition of the excess cable shall be precisely noted in the test report.

The charging / communication cable at vehicle side shall hang vertically at a distance of 100 mm (+200/-0 mm) from the vehicle body.

The whole cable shall be placed on a non-conductive, low relative permittivity (dielectric-constant) material ($\epsilon_r \leq 1.4$), at 100 mm (± 25 mm) above the ground plane.”

Paragraph 4.1., amend to read:

“4.1. The limits apply throughout the frequency range 30 to 1,000 MHz for measurements performed in ~~a semi-anechoic chamber~~ **an absorber lined shielded enclosure (ALSE)** or an outdoor test site.”

Paragraph 4.2., amend to read:

“4.2. Measurements can be performed with either quasi-peak or peak detectors. The limits given in paragraphs 6.2. and ~~6.5.~~ **7.2.** of this Regulation are for quasi-peak detectors. If peak detectors are used a correction factor of 20 dB as defined in CISPR 12 shall be applied.”

Annex 4, Appendix 1, amend to read:

“Annex 4 – Appendix 1

Figure 1

Clear horizontal surface free of electromagnetic reflection delimitation of the surface defined by an ellipse

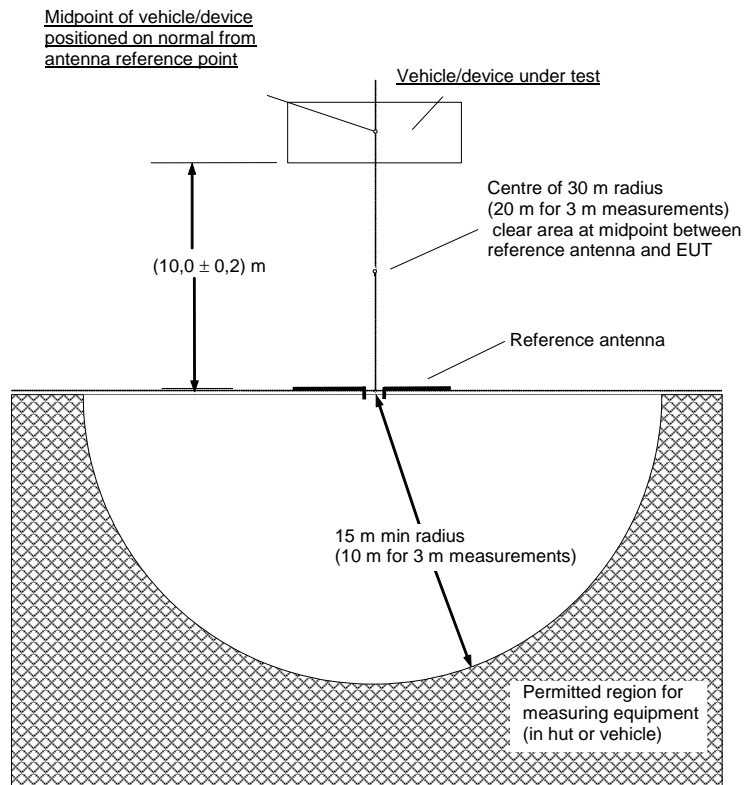

Figure 2
Position of antenna in relation to the vehicle:

Figure 2a
Dipole antenna in position to measure the vertical radiation components

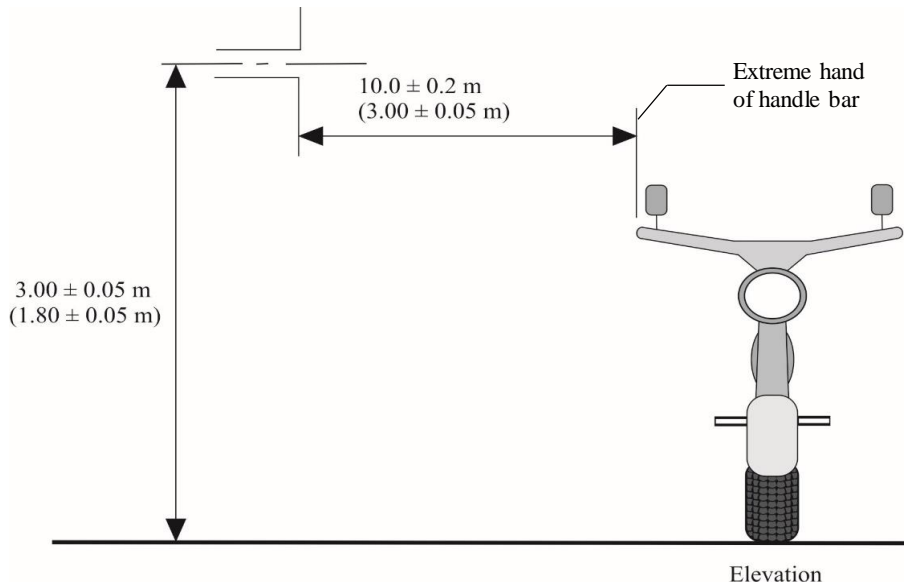

Figure 2b
Dipole antenna in position to measure the horizontal radiation components

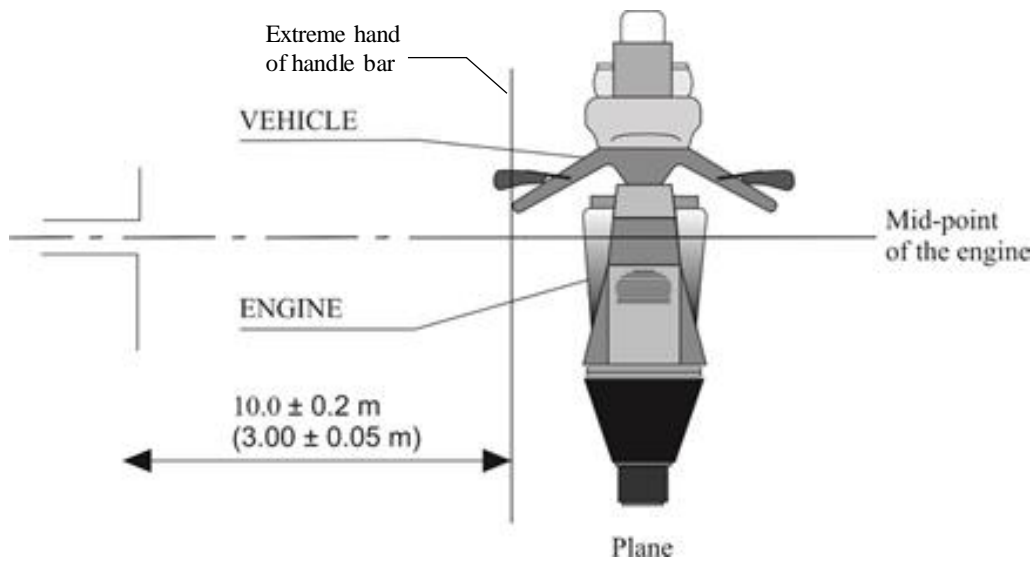

Figure 3
Vehicle in configuration "REESS charging mode" coupled to the power grid:
Example of test set-up for vehicle with plug located on vehicle side (AC powered without communication)

Figure 3a

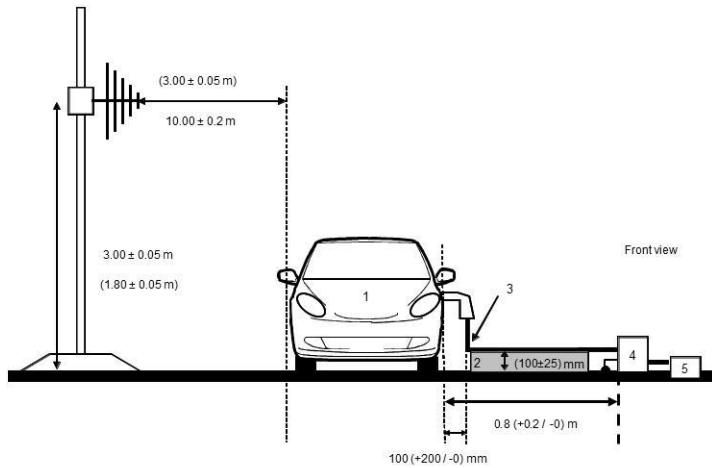
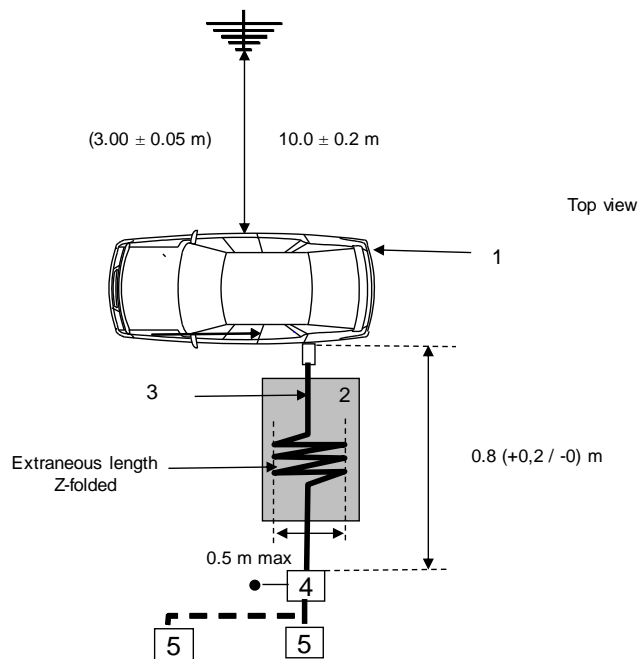

Figure 3b



Legend:

- 1 Vehicle under test**
- 2 Insulating support**
- 3 Charging cable**
- 4 AMN(s) or DC-charging-AN(s) grounded**
- 5 Power mains socket**

Vehicle in configuration "REESS charging mode" coupled to the power grid

Example of test setup for vehicle with plug located front/rear of vehicle (AC powered without communication)

Figure 3c

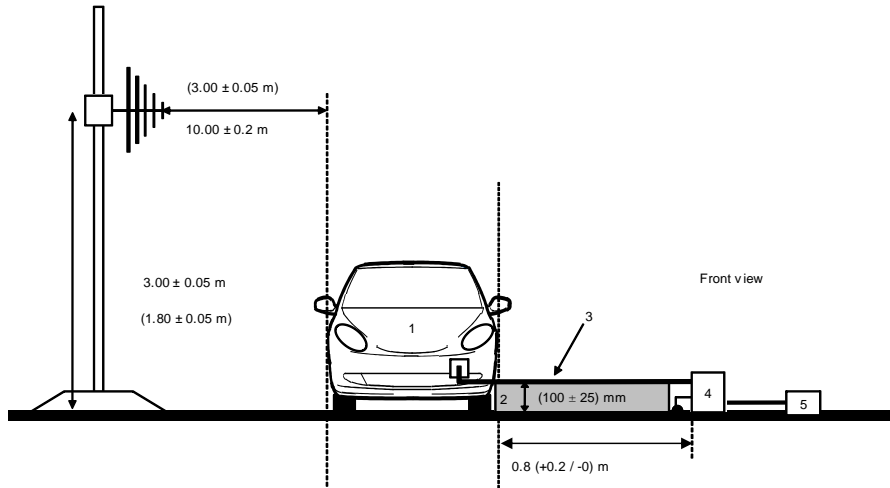
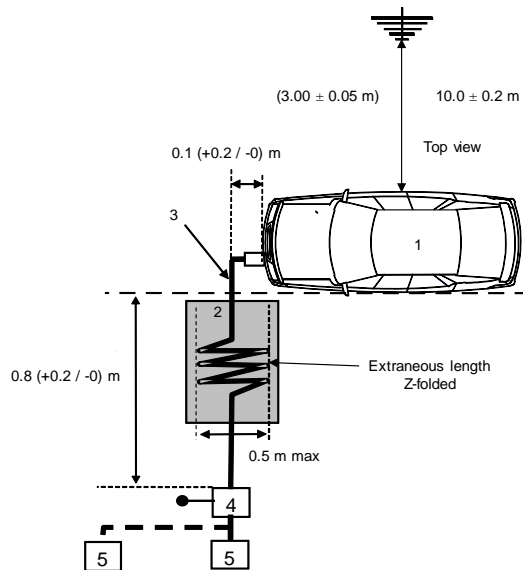

Figure 3d



Legend:

- 1 Vehicle under test
- 2 Insulating support
- 3 Charging cable
- 4 AMN(s) or DC-charging-AN(s) grounded
- 5 Power mains socket

Vehicle in configuration "REESS charging mode" coupled to the power grid

Example of test set-up for vehicle with plug located on vehicle side (AC or DC powered with communication)

Figure 3e

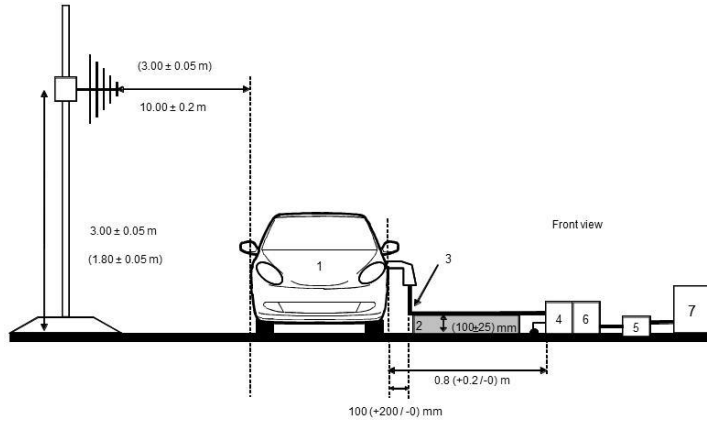
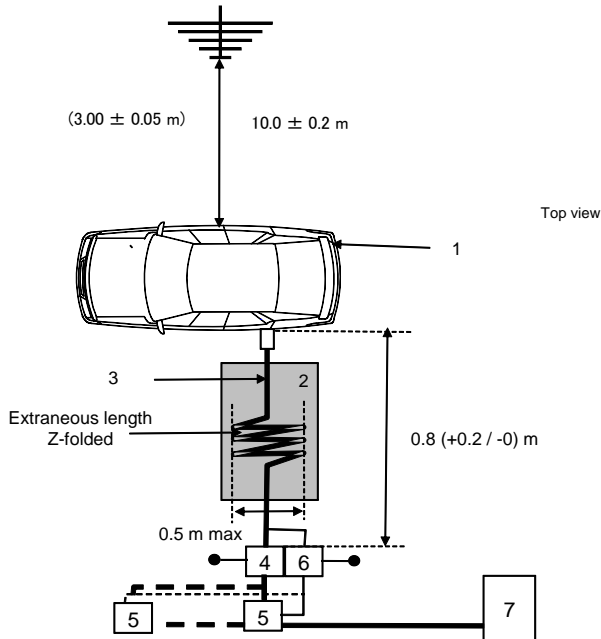

Figure 3f



Legend:

- 1 Vehicle under test
- 2 Insulating support
- 3 Charging / communication cable
- 4 AMN(s) or DC-charging-AN(s) grounded
- 5 Power mains socket
- 6 Impedance stabilization(s) grounded
- 7 Charging station

Vehicle in configuration "REESS charging mode" coupled to the power grid

Example of test setup for vehicle with plug located front/rear of the vehicle (AC or DC powered with communication)

Figure 3g

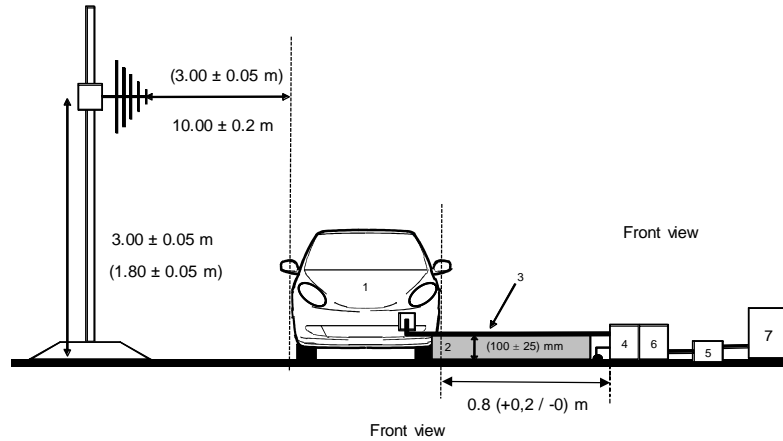
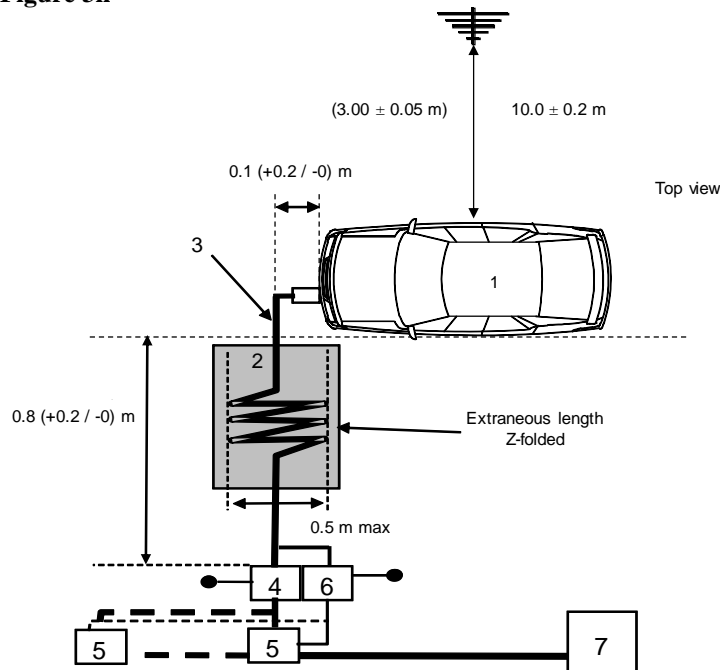

Figure 3h



Legend:

- 1 Vehicle under test
- 2 Insulating support
- 3 Charging / communication cable
- 4 AMN(s) or DC-charging-AN(s) grounded
- 5 Power mains socket
- 6 Impedance stabilisation(s) grounded
- 7 Charging station"

Annex 5,

Paragraph 3.1., amend to read:

“3.1. The limits apply throughout the frequency range 30 to 1,000 MHz for measurements performed in ~~a semi-anechoic chamber~~ **an absorber lined shielded enclosure (ALSE)** or an outdoor test site.”

Paragraph 3.3., Tables 1 and 2, amend to read:

“Table 1
Spectrum analyser parameters

Frequency range MHz	Peak detector		Quasi-peak detector		Average detector	
	RBW at -3 dB	Scan time	RBW at -6 dB	Scan time	RBW at -3 dB	Scan time
30 to 1,000	100/120 kHz	100 ms/MHz	120 kHz	20 s/MHz	100/120 kHz	100 ms/MHz

Note: If a spectrum analyser is used for peak measurements, the video bandwidth shall be at least three times the resolution bandwidth (RBW).

Table 2
Scanning receiver parameters

Frequency range MHz	Peak detector			Quasi-peak detector			Average detector		
	BW at -6 dB	Step size ^a	Dwell time	BW at -6 dB	Step size ^a	Dwell time	BW at -6 dB	Step size ^a	Dwell time
30 to 1,000	120 kHz	50 kHz	5 ms	120 kHz	50 kHz	1 s	120 kHz	50 kHz	5 ms

^a “~~For purely broadband disturbances, the maximum frequency step size may be increased up to a value not greater than the bandwidth value.~~”

Annex 6,

Paragraph 2.2.1.1., amend to read:

“2.2.1.1. ~~The vehicle shall be immobilized, engine OFF and in charging mode.~~
The vehicle shall be immobilized, the engine(s) (ICE and / or electrical engine) shall be OFF and in charging mode.”

Paragraph 2.2.1.2., amend to read:

“2.2.1.2. Basic vehicle conditions
The paragraph defines minimum test conditions (as far as applicable) and failures criteria for vehicle immunity tests. Other vehicle systems, which can affect immunity related functions, shall be tested in a way to be agreed between manufacturer and Technical Service.

"REESS charging mode" vehicle test conditions	Failure criteria
<p>The REESS shall be in charging mode. The REESS State of charge (SOC) shall be kept between 20 per cent and 80 per cent of the maximum SOC during the whole frequency range measurement (this may lead to split the measurement in different sub-bands with the need to discharge the vehicle's traction battery before starting the next sub-bands). If the current consumption can be adjusted, then the current shall be set to at least 20 per cent of its nominal value.</p> <p>In case of multiple batteries the average state of charge must be considered.</p>	<p>Vehicle sets in motion.</p>

”

Paragraph 2.2.1.3., amend to read:

“2.2.1.3. ~~All other equipment which can be switched on permanently by the driver or passenger should be OFF.~~

All other equipment which can be switched ON by the driver or passengers shall be OFF.”

Paragraph 2.3., amend to read:

“2.3. Charging station / Power mains

The charging station may be placed either in the test location or outside the test location.

Note 1: If the communication between the vehicle and the charging station could be simulated, the charging station may be replaced by the supply from power mains.

In both case duplicated power mains and communication lines socket(s) shall be placed in the test location with the following conditions:

- (a) It shall be placed on the ground plane.
- (b) The length of the harness between the power mains/communication lines socket and the ~~AN(s)~~ **AMN(s)/DC-charging-AN(s)/IS(s)** shall be kept as short as possible **but not necessarily aligned with the charging cable.**
- (c) The harness between the power mains/communication lines socket and the ~~AN(s)~~ **AMN(s)/DC-charging-AN(s)/IS(s)** shall be placed as close as possible to the ground plane.

Note 2: The power mains and communication lines socket(s) should be filtered.

If the charging station is placed inside the test location then harness between charging station and the power mains / communication lines socket shall be placed with the following conditions:

- (a) The harness at charging station side shall hang vertically down to the ground plane;
- (b) The ~~extraneous~~ **excess** length shall be placed as close as possible of the ground plane and "Z-folded" if necessary.

Note 3: The charging station should be placed outside the beam width of the emitting antenna.”

Paragraph 2.4., amend to read:

“2.4. Artificial networks

The ~~AN(s)~~ **AMN(s)/DC-charging-AN(s)** shall be mounted directly on the ground plane. The cases of the ~~AN(s)~~ **AMN(s)/DC-charging-AN(s)** shall be bonded to the ground plane.

The measuring port of each ~~AN~~ **AMN/DC-charging-AN** shall be terminated with a 50 Ω load.

The ~~AN~~ **AMN(s)/DC-charging-AN(s)** shall be placed as defined in Figures 4a to 4h.”

Paragraph 2.6., amend to read:

“2.6. Power charging / Communication cable

The power charging / communication cable shall be placed in a straight line between the ~~AN(s)~~ **AMN(s)/DC-charging-AN(s)/IS(s)** and the vehicle charging plug. The projected cable length shall be 0.8 m (+0.2/-0 m).

If the length of the cable is longer than 1 m, the ~~extraneous~~ **excess** length shall be "Z-folded" **with a width of in-**less than 0.5 m ~~width~~, **and the “Z-folded” portion should be placed approximately around the middle of the distance between the AMN/ DC-charging-AN and the vehicle.**

If it is impractical to do so because of cable bulk or stiffness, or because the testing is being done at a user installation, the disposition of the excess cable shall be precisely noted in the test report.

The charging / communication cable at vehicle side shall hang vertically at a distance of 100 mm (+200/-0 mm) from the vehicle body.

The whole cable shall be placed on a non-conductive, low relative permittivity (dielectric-constant) material ($\epsilon_r \leq 1.4$), at 100 mm (± 25 mm) above the ground plane.”

Paragraph 3.3.5., amend to read:

“3.3.5. If it is decided to radiate the rear of the vehicle, the reference point shall be established as in paragraphs 3.3.1. to 3.3.4. above. The vehicle shall then be installed facing away from the antenna and positioned as if it had been horizontally rotated **180°** around its centre point, i.e. such that the distance from the antenna to the nearest part of the outer body of the vehicle remains the same. This is illustrated in Figure 3 of Appendix 1 to this annex.”

Paragraph 5.1.2., amend to read;

“5.1.2. Calibration

For TLS one field probe at the ~~facility~~ **vehicle** reference point shall be used.

For antennas four field probes at the ~~facility~~ **vehicle** reference line shall be used.”

Paragraph 5.1.3., amend to read:

“5.1.3. Test phase

The vehicle shall be positioned with the centre line of the vehicle on the facility reference point or line. The vehicle shall normally face a fixed antenna. However, where the electronic control units and the associated wiring harness are predominantly in the rear of the vehicle, the test should normally be carried out with the vehicle facing away from the antenna **and**

positioned as if it had been horizontally rotated 180° around its centre point, i.e. such that the distance from the antenna to the nearest part of the outer body of the vehicle remains the same. In the case of long vehicles (i.e. excluding vehicles of categories L, M₁ and N₁), which have electronic control units and associated wiring harness predominantly towards the middle of the vehicle, a reference point may be established based on either the right side surface or the left side surface of the vehicle. This reference point shall be at the midpoint of the vehicle's length or at one point along the side of the vehicle chosen by the manufacturer in conjunction with the Type Approval Authority after considering the distribution of electronic systems and the layout of any wiring harness.

Such testing may only take place if the physical construction of the chamber permits. The antenna location shall be noted in the test report.”

Annex 6, Appendix 1, amend to read:

“Annex 6 – Appendix 1

Figure 1

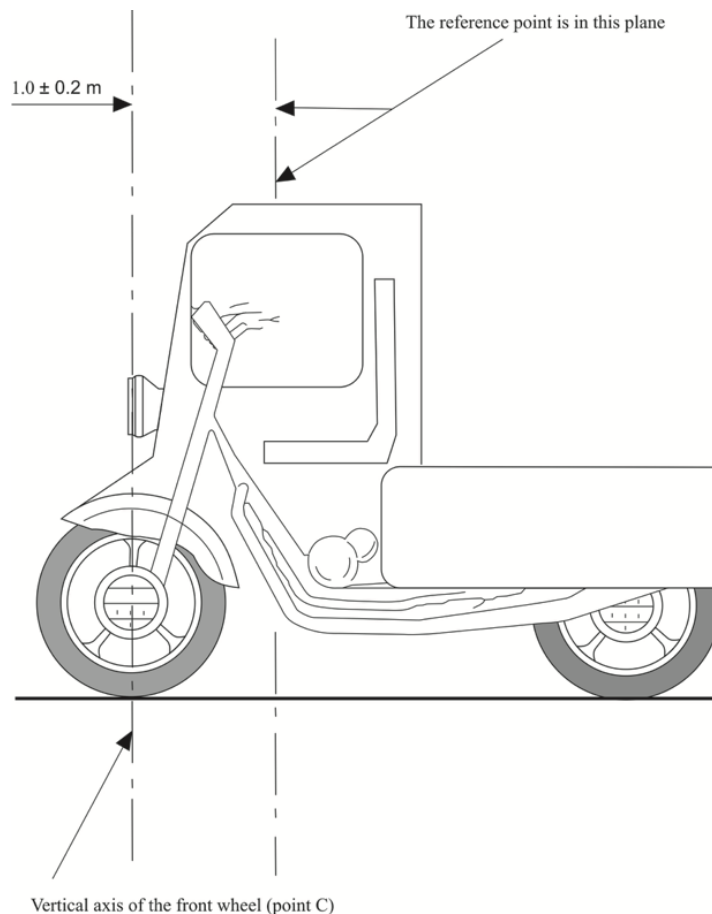

Figure 2

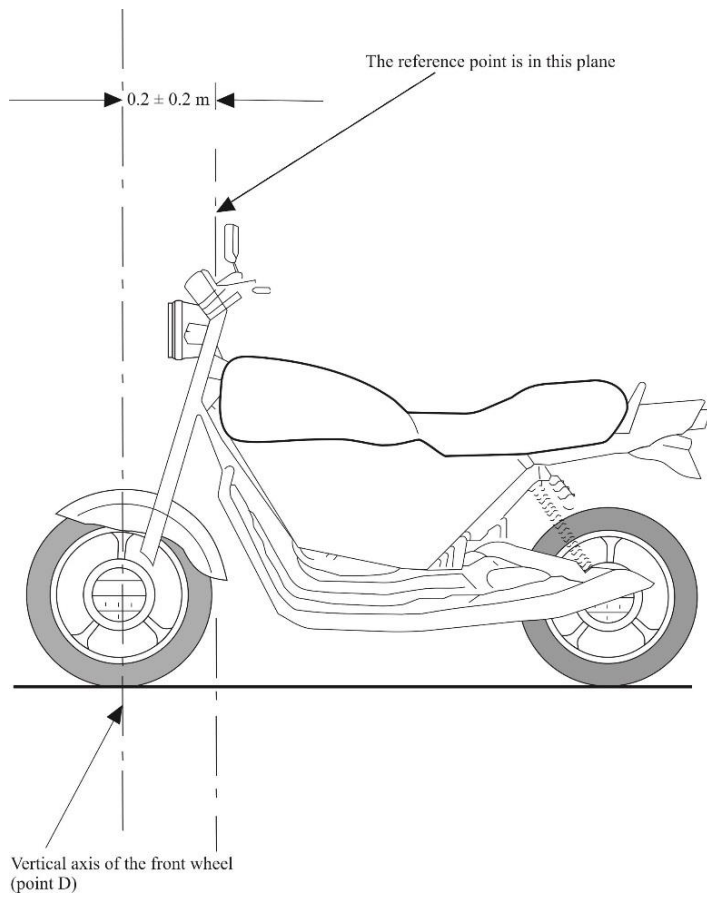

Figure 3

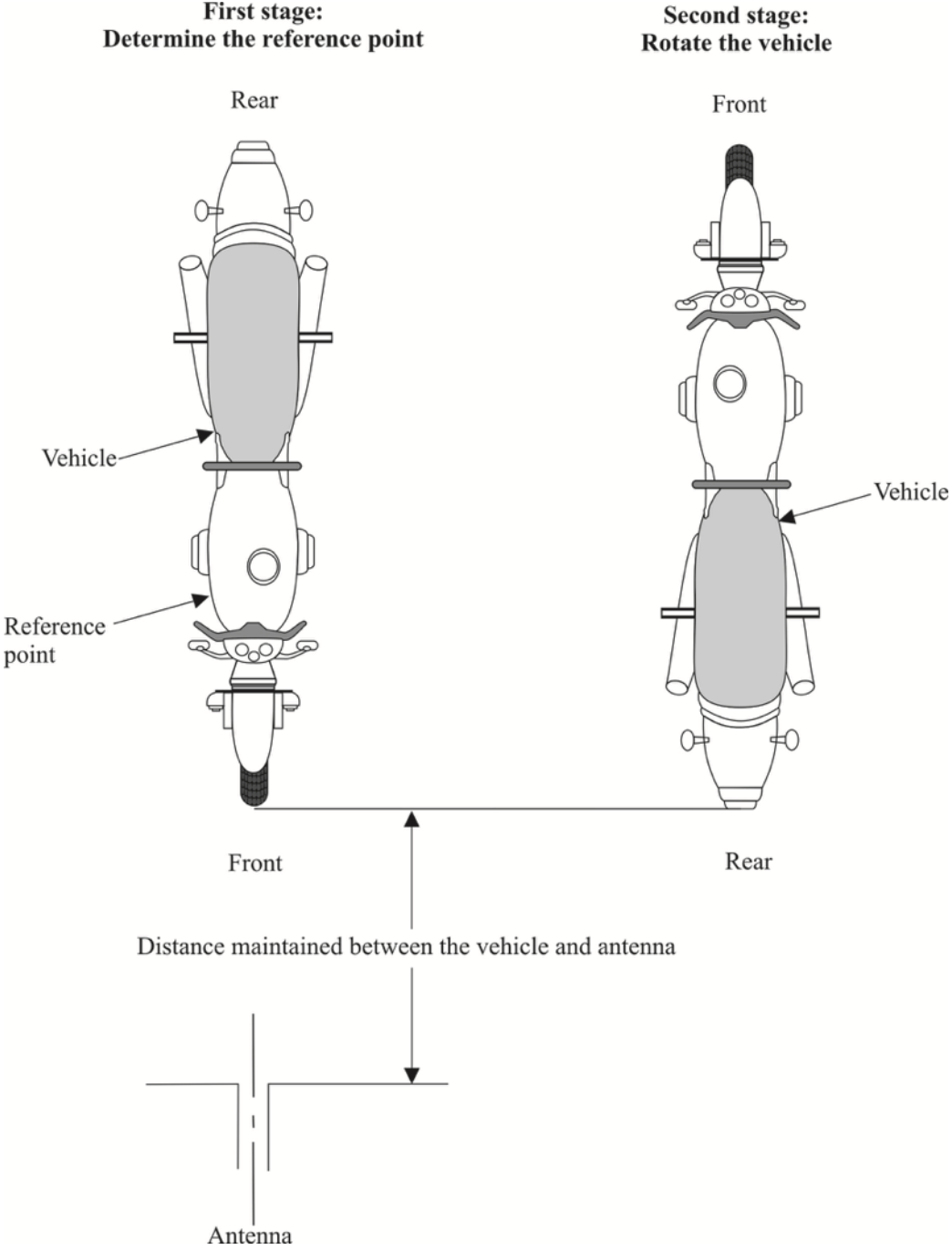

Figure 4

Vehicle in configuration "REESS charging mode coupled to the power grid"

Example of test set-up for vehicle with plug located on the vehicle side (AC power charging without communication)

Figure 4a

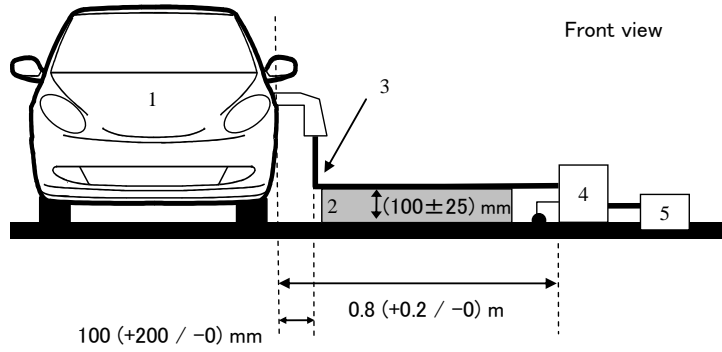
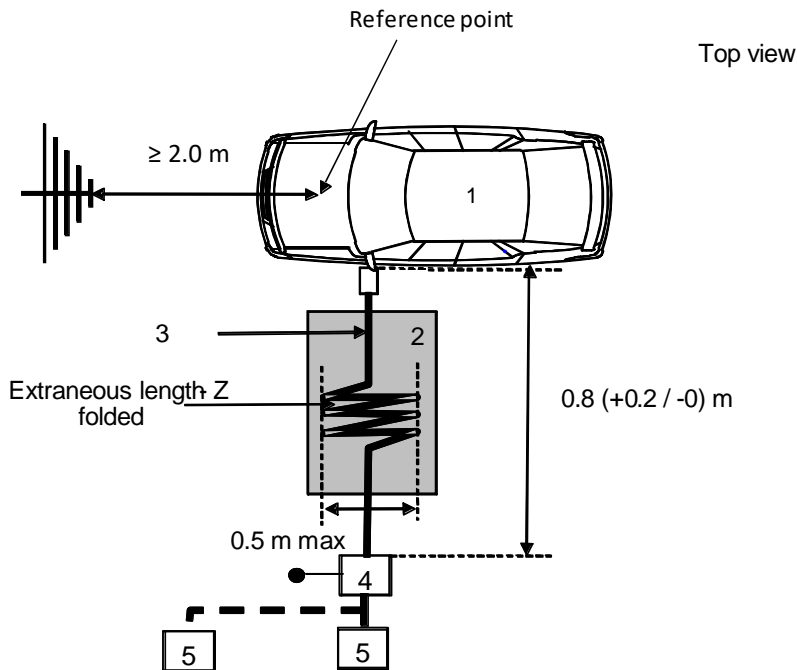

Figure 4b



Legend:

- 1 Vehicle under test
- 2 Insulating support
- 3 Charging cable
- 4 AMN(s) or DC-charging-AN(s) grounded
- 5 Power mains socket

Example of test set-up for vehicle with plug located front / rear of vehicle (AC power charging without communication)

Figure 4c

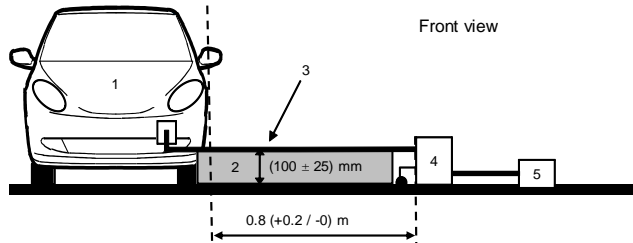
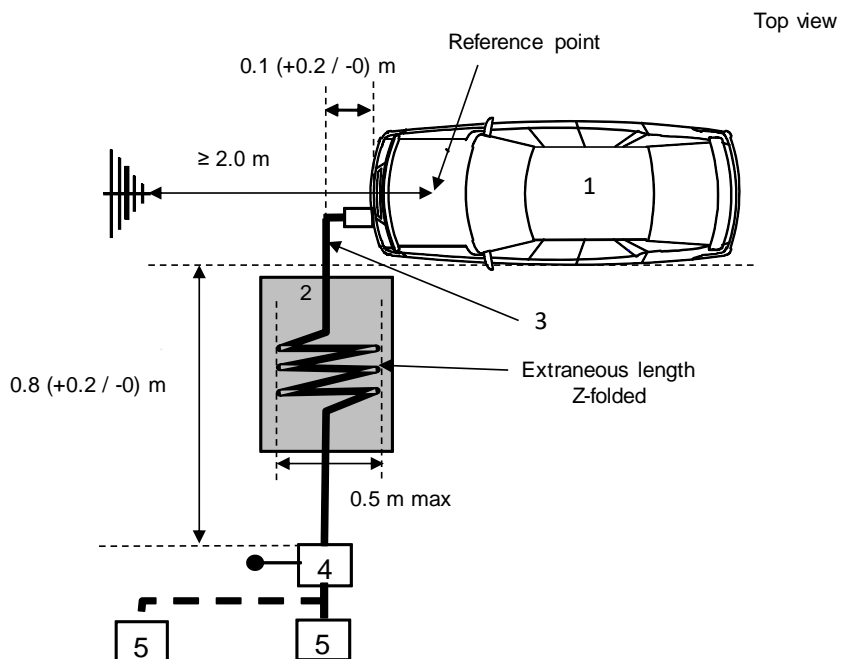

Figure 4d



Legend:

- 1** Vehicle under test
- 2** Insulating support
- 3** Charging cable
- 4** AMN(s) or DC-charging-AN(s) grounded
- 5** Power mains socket

Example of test set-up for vehicle with plug located on vehicle side (AC or DC power charging with communication)

Figure 4e

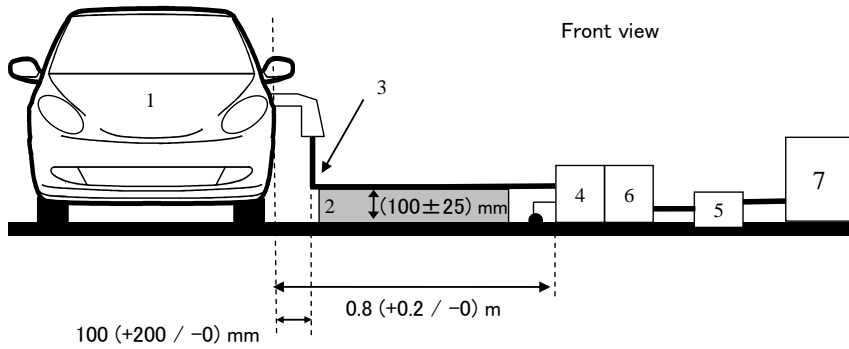
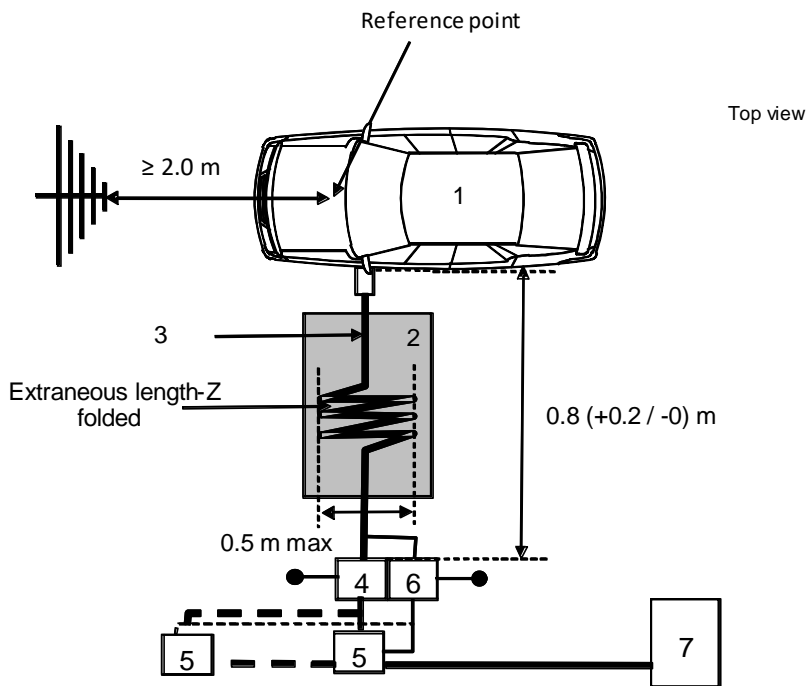

Figure 4f



Legend:

- 1** Vehicle under test
- 2** Insulating support
- 3** Charging / communication cable
- 4** AMN(s) or DC-charging-AN(s) grounded
- 5** Power mains socket
- 6** Impedance stabilisation(s) grounded
- 7** Charging station

Example of test set-up for vehicle with plug located front / rear of the vehicle (AC or DC power charging with communication)

Figure 4g

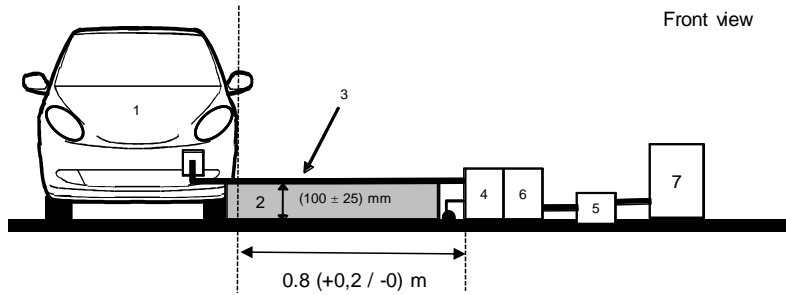
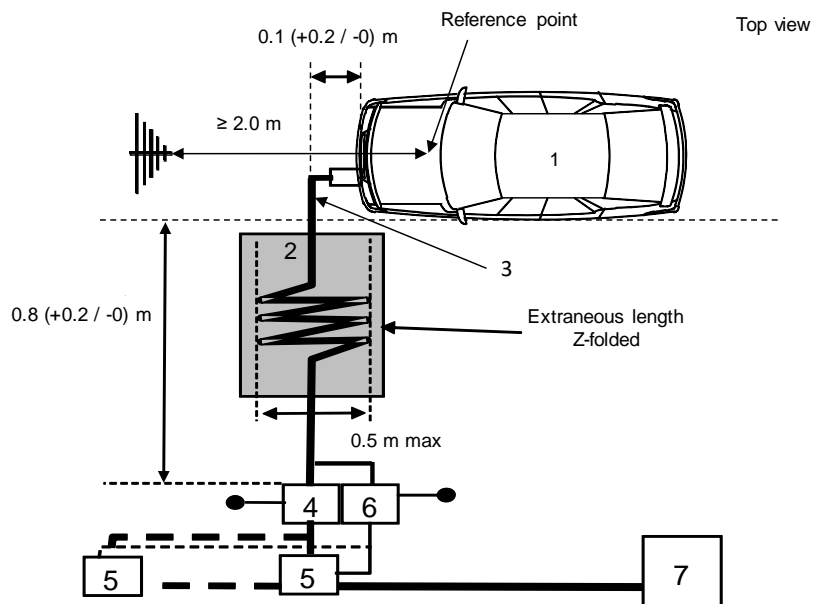

Figure 4h



Legend:

- 1** Vehicle under test
- 2** Insulating support
- 3** Charging / communication cable
- 4** AMN(s) or DC-charging-AN(s) grounded
- 5** Power mains socket
- 6** Impedance stabilisation(s) grounded
- 7** Charging station"

Annex 7,

Paragraph 2.1., amend to read:

"2.1. The ESA under test shall be in normal operation mode, preferably in maximum load.

ESAs involved in "REESS charging mode coupled to the power grid" shall be in charging mode.

The state of charge (SOC) of the traction battery shall be kept between 20 per cent and 80 per cent of the maximum SOC during the whole frequency range measurement (this may lead to split the measurement in different sub-bands with the need to discharge the vehicle's traction battery before starting the next sub-bands)

If the test is not performed with a REESS the ESA should be tested at rated current. ~~If the current consumption can be adjusted, then the current shall be set to at least 80 per cent of its nominal value.~~

If the current consumption can be adjusted, then the current shall be set to at least 80 per cent of its nominal value for AC charging.

If the current consumption can be adjusted, then the current shall be set to at least 80 per cent of its nominal value for DC charging unless another value is agreed with the type approval authorities."

Paragraph 4.1., amend to read:

"4.1. The limits apply throughout the frequency range 30 to 1,000 MHz for measurements performed in ~~a semi anechoic chamber~~ **absorber lined shielded enclosure (ALSE)** or ~~outdoor test sites~~ **open area test site (OATS).**"

Paragraph 4.2., amend to read:

4.2. Measurements can be performed with either quasi-peak or peak detectors. The limits given in paragraphs ~~6.2~~ **6.5.** and ~~6.5.~~ **7.10.** of this Regulation are for quasi-peak detectors. If peak detectors are used a correction factor of 20 dB as defined in CISPR 12 shall be applied.

Paragraph 4.3., table 2, amend to read:

"Table 2

Scanning receiver parameters

Frequency range MHz	Peak detector			Quasi-peak detector			Average detector		
	BW at -6 dB	Step size [#]	Dwell time	BW at -6 dB	Step size [#]	Dwell time	BW at -6 dB	Step size [#]	Dwell time
30 to 1,000	120 kHz	50 kHz	5 ms	120 kHz	50 kHz	1 s	120 kHz	50 kHz	5 ms

[#] ~~For purely broadband disturbances, the maximum frequency step size may be increased up to a value not greater than the bandwidth value.~~

Note: For emissions generated by brush commutator motors without an electronic control unit, the maximum step size may be increased up to five times the bandwidth."

Annex 7, Appendix, delete and replace by:

“Annex 7 - Appendix

Figure 1

Test configuration for ESAs involved in "REESS charging mode coupled to the power grid" (example for biconical antenna)

Top view (horizontal polarization)

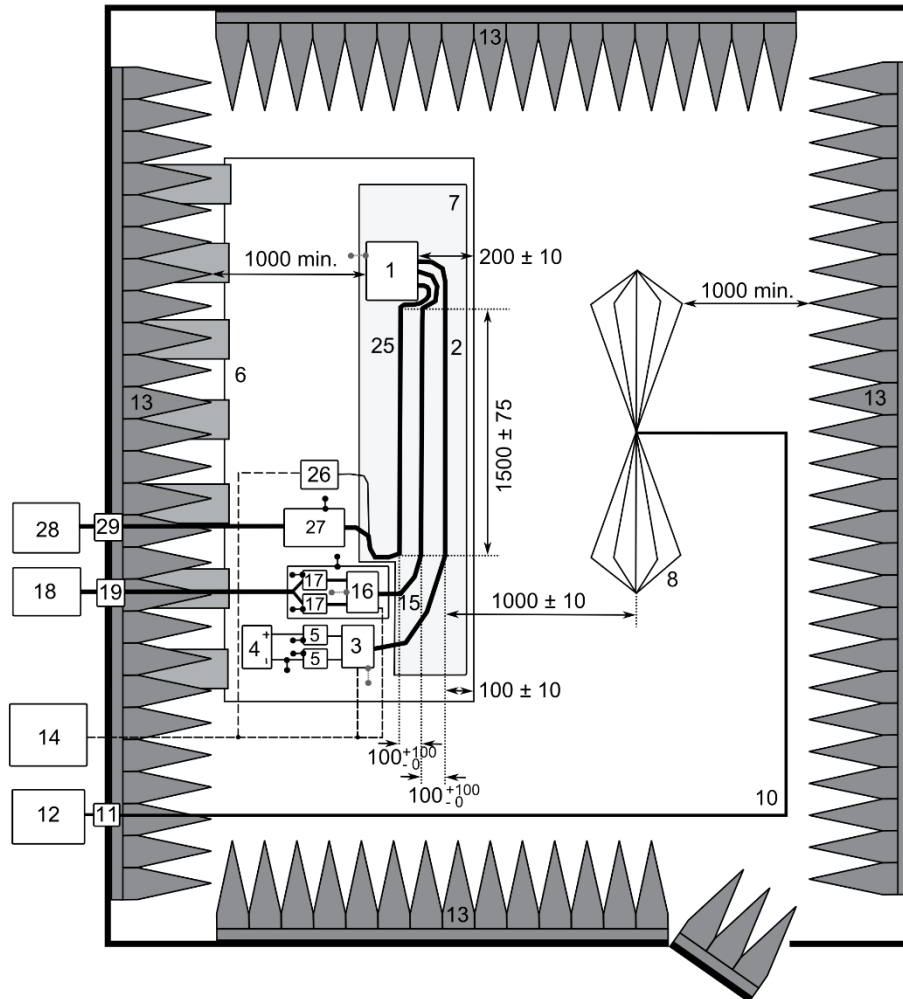

Legend:

- | | | | |
|----|---|----|---|
| 1 | ESA (grounded locally if required in test plan) | 13 | RF absorber material |
| 2 | LV Test harness | 14 | Stimulation and monitoring system |
| 3 | LV Load simulator (placement and ground connection according to CISPR 25 paragraph 6.4.2.5) | 15 | HV harness |
| 4 | Power supply (location optional) | 16 | HV load simulator |
| 5 | LV Artificial network (AN) | 17 | HV AN |
| 6 | Ground plane (bonded to shielded enclosure) | 18 | HV power supply |
| 7 | Low relative permittivity support ($\epsilon_r \leq 1.4$) | 19 | HV feed-through |
| 8 | Biconical antenna | 25 | AC/DC charger harness |
| 10 | High-quality coaxial cable e.g. double-shielded (50 Ω) | 26 | AC/DC load simulator (e.g. Programmable Logic Controller (PLC)) |
| 11 | Bulkhead connector | 27 | AMN(s) or DC-charging-AN(s) |
| 12 | Measuring instrument | 28 | AC/DC power supply |
| | | 29 | AC/DC feed-through |

Annex 8,

Paragraph 4.1., amend to read:

“4.1. The limits apply throughout the frequency range 30 to 1,000 MHz for measurements performed in ~~semi-anechoic chambers~~ **absorber lined shielded enclosure (ALSE)** or ~~outdoor test sites~~ **open area test site (OATS).**”

Paragraph 4.3., tables 1 and 2, amend to read:

“Table 1

Spectrum analyser parameters

Frequency range MHz	Peak detector		Quasi-peak detector		Average detector	
	RBW at -3 dB	Scan time	RBW at -6 dB	Scan time	RBW at -3 dB	Scan time
30 to 1,000	100/120 kHz	100 ms/MHz	120 kHz	20 s/MHz	100/120 kHz	100 ms/MHz

Note: If a spectrum analyser is used for peak measurements, the video band width shall be at least three times the resolution bandwidth (RBW)

Table 2

Scanning receiver parameters

Frequency range MHz	Peak detector			Quasi-peak detector			Average detector		
	BW at -6 dB	Step size ^a	Dwell time	BW at -6 dB	Step size ^a	Dwell time	BW at -6 dB	Step size ^a	Dwell time
30 to 1,000	120 kHz	50 kHz	5 ms	120 kHz	50 kHz	1 s	120 kHz	50 kHz	5 ms

^a For purely broadband disturbances, the maximum frequency step size may be increased up to a value not greater than the bandwidth value.

Note: For emissions generated by brush commutator motors without an electronic control unit, the maximum step size may be increased up to five times the band width.”

Annex 9,

Paragraph 4.3.2., amend to read:

“4.3.2. Test methodology

~~The test shall be performed according to ISO 11452-4 on a test bench. As an alternative the ESA may be tested while installed in the vehicle according to ISO 11451-4 with the following characteristics:~~

- ~~(a) The injection probe shall be positioned in 150 mm distance to the ESA to be tested;~~
- ~~(b) The reference method shall be used to calculate injected currents from forward power;~~
- ~~(c) The frequency range of the method is limited by the injection probe specification.~~

The test shall be performed according to ISO 11452-4 on a test bench with the following characteristics:

- **BCI test method with substitution method and injection probe positioned at 150 mm distance to the ESA**
- **Or BCI test method with closed loop method and injection probe positioned at 900 mm distance to the ESA**

As an alternative the ESA may be tested while installed in the vehicle according to ISO 11451-4 with the following characteristics:

- **BCI test method with substitution method and injection probe positioned at 150 mm distance to the ESA”**

Paragraph 4.3.2.1., amend to read:

“4.3.2.1. ~~For ESAs in configuration "REESS charging mode coupled to the power grid", the test arrangement shall be according to Appendix 4 to this annex.~~

For ESAs in configuration "REESS charging mode coupled to the power grid", an example of test arrangement (for substitution method) is given in Appendix 4 to this annex.”

Annex 9, Appendix 3, amend to read:

“Annex 9 – Appendix 3

Absorber chamber test

Test configuration for ESA's involved in "REESS charging mode coupled to the power grid". The test shall be performed according to ISO 11452-2.

Top view (Vertical polarization)

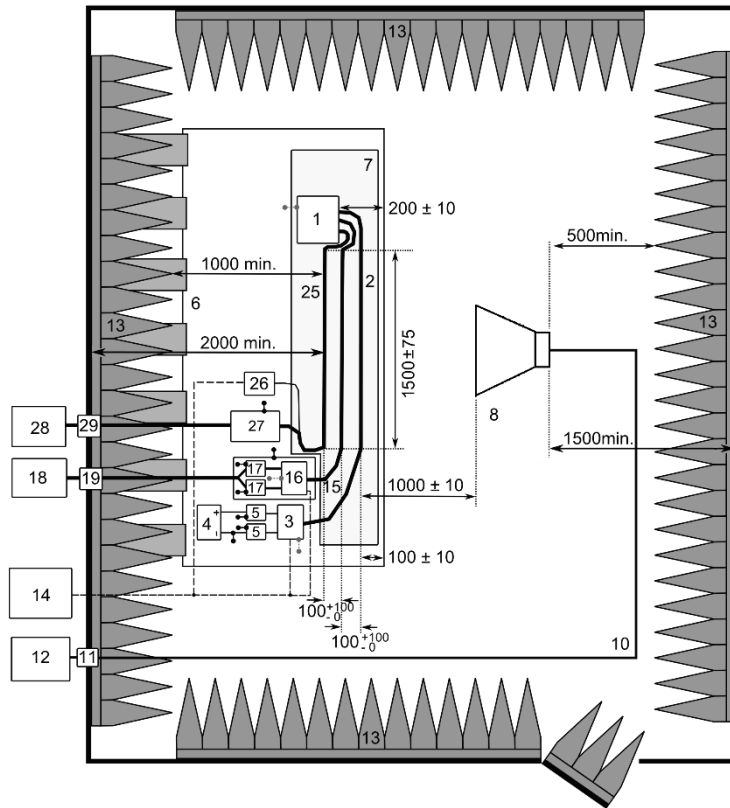

Legend:

1	ESA (grounded locally if required in test plan)	13	RF absorber material
2	LV Test harness	14	Stimulation and monitoring system
3	LV Load simulator (placement and ground connection according to CISPR 25 paragraph 6.4.2.5.)	15	HV harness
4	Power supply (location optional)	16	HV load simulator
5	LV Artificial network (AN)	17	HV AN
6	Ground plane (bonded to shielded enclosure)	18	HV power supply
7	Low relative permittivity support ($\epsilon_r \leq 1.4$)	19	HV feed-through
8	Horn antenna	25	AC/DC charger harness
10	High-quality coaxial cable e.g. double-shielded (50 Ω)	26	AC/DC load simulator (e.g. PLC)
11	Bulkhead connector	27	50 μ H Line Impedance Stabilization Network (LISN) (AC) or HVAN (DC) AMN(s) or DC-charging-AN(s)
12	RF signal generator and amplifier	28	AC/DC power supply
		29	AC/DC feed-through”

Annex 9, Appendix 4, amend to read:

“Annex 9 – Appendix 4

BCI test

Test configuration for ESAs involved in "REESS charging mode coupled to the power grid". The test shall be performed according to ISO 11452-4.

Top view (example of substitution method)

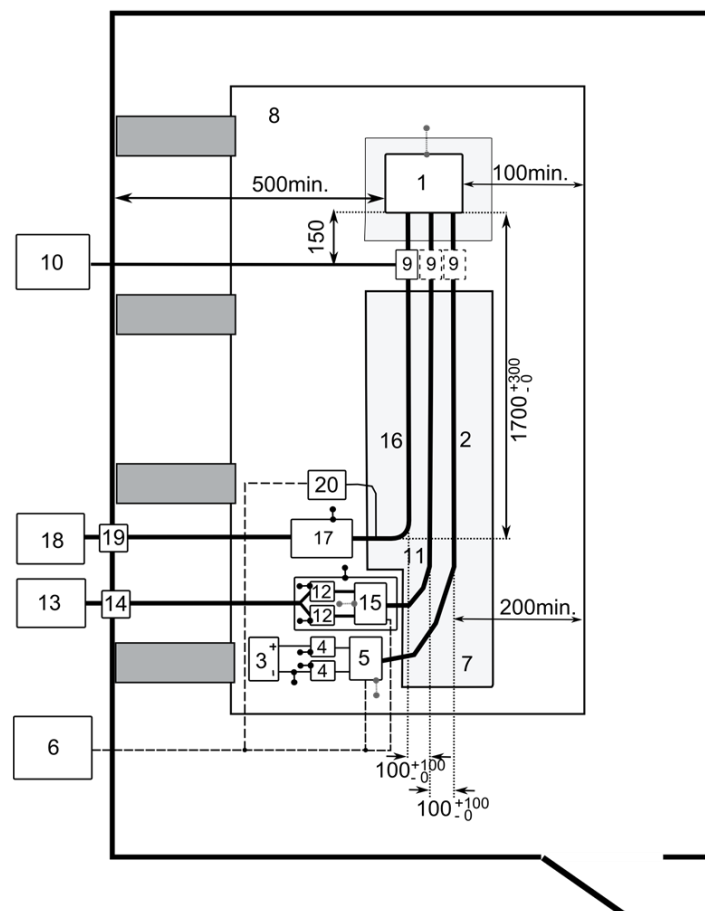

Legend:

1	ESA (grounded locally if required in test plan)	11	HV DC harness
2	LV Test harness	12	HV AN
3	LV supply	13	HV DC load
4	LV LISN	14	HV DC feed-through
5	LV load simulator	15	HV DC load simulator
6	Stimulation and monitoring system	16	HV AC/DC charger harness
7	Low relative permittivity support	17	50 μ H LISN (AC) or HV AN (DC) AMN(s) or DC-charging-AN(s)
8	Ground plane	18	HV AC/DC power supply
9	Injection probe	19	HV AC/DC feed-through
10	RF signal amplifier and generator	20	HV AC/DC load simulator (e.g. PLC)

Annex 11,

Paragraph 2.1., amend to read:

“2.1. The vehicle shall be in configuration "REESS charging mode coupled to the power grid".

The state of charge (SOC) of the traction battery shall be kept between 20 per cent and 80 per cent of the maximum SOC during the whole time duration of the measurement (this may lead to the measurement being **splitting** into different time slots with the need to discharge the vehicle’s traction battery before starting the next time slot). If the current consumption can be adjusted, then the current shall be set to at least 80 per cent of its nominal value **for AC charging.**

In case of multiple batteries the average state of charge must be considered.

~~The vehicle shall be immobilized, engine OFF.~~

The vehicle shall be immobilized, the engine(s) (ICE and / or electrical engine) shall be OFF and in charging mode.

~~And all other equipment which can be switched on permanently by the driver or passenger should be OFF.~~

All other equipment which can be switched ON by the driver or passengers shall be OFF.”

Paragraph 3.2., amend to read:

“3.2. The test set-up for single phase / **three-phase** vehicle in configuration "REESS charging mode coupled to the power grid" is shown in Figure 1a to 1d of Appendix 1 to this annex.”

Paragraph 3.3., delete.

Annex 11, Appendix 1, amend to read:

“Annex 11 – Appendix 1

Figure 1
Vehicle in configuration "REESS charging mode coupled to the power grid"

Example of test setup for vehicle with plug located on vehicle side

Figure 1a

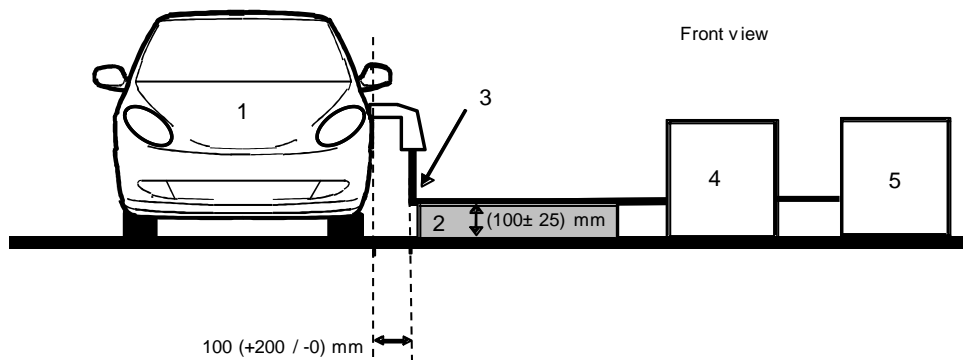
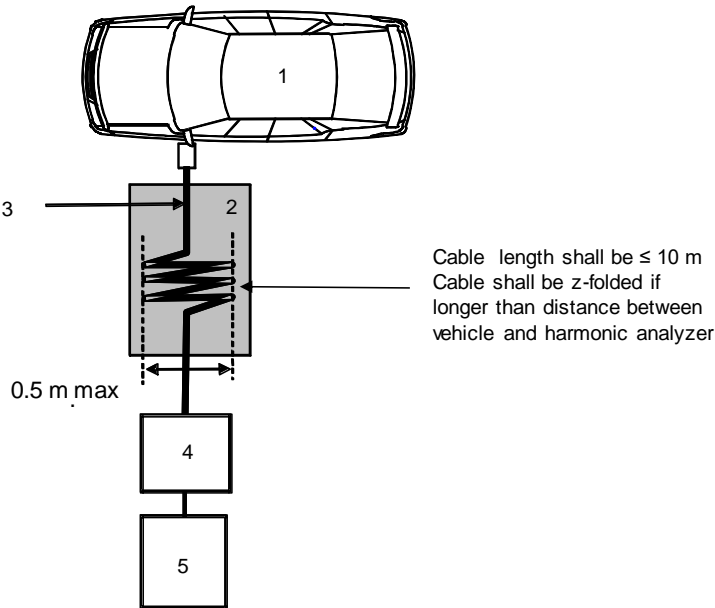

Figure 1b

Top view



Legend:

- 1 Vehicle under test
- 2 Insulating support
- 3 Charging cable
- 4 Harmonic analyzer
- 5 Power supply

Example of test setup for vehicle with plug located front/rear of vehicle

Figure 1c

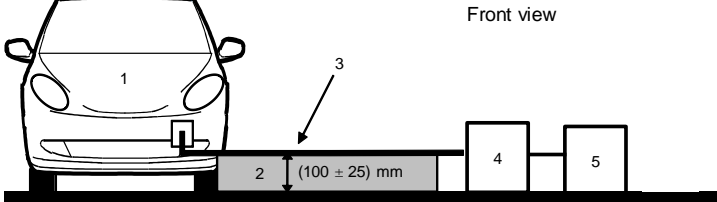
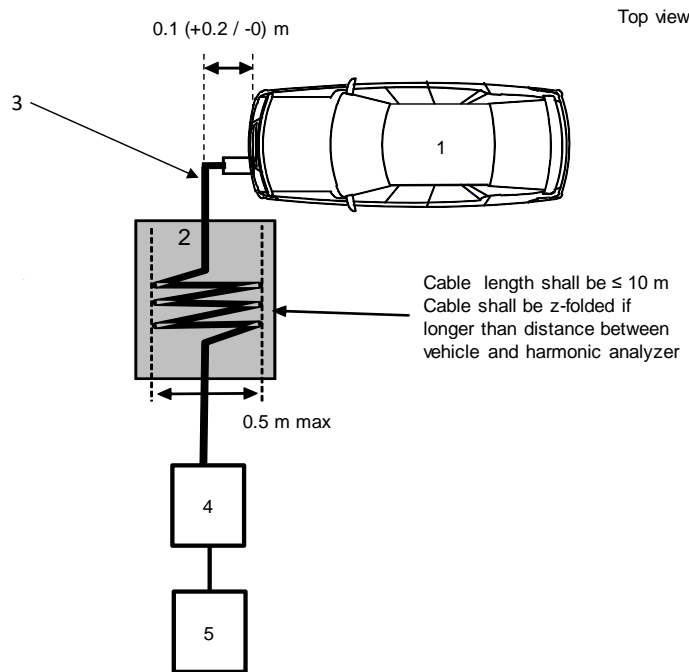

Figure 1d



Legend:

- 1 Vehicle under test
- 2 Insulating support
- 3 Charging cable
- 4 Harmonic analyzer
- 5 Power supply

Annex 12,

Paragraph 2.1., amend to read:

“2.1. The vehicle shall be in configuration "REESS charging mode coupled to the power grid".

The state of charge (SOC) of the traction battery shall be kept between 20 per cent and 80 per cent of the maximum SOC during the whole time duration of the measurement (this may lead to the measurement being **splitting** into different time slots with the need to discharge the vehicle’s traction battery before starting the next time slot). If the current consumption can be adjusted, then the current shall be set to at least 80 per cent of its nominal value **for AC charging.**

In case of multiple batteries the average state of charge must be considered.

~~The vehicle shall be immobilized, engine OFF.~~

~~And all other equipment which can be switched on permanently by the driver or passenger should be OFF.~~

The vehicle shall be immobilized, the engine(s) (ICE and / or electrical engine) shall be OFF and in charging mode.

All other equipment which can be switched ON by the driver or passengers shall be OFF.”

Paragraph 3.3., amend to read:

“3.3. The test set-up for vehicle in configuration "REESS charging mode coupled to the power grid" is shown in Figures 1a to 1d and 1e of Appendix 1 to this annex.”

Annex 12, Appendix 1, amend to read:

“Annex 12 - Appendix 1

Figure 1
Vehicle in configuration "REESS charging mode coupled to the power grid"
Example of test setup for vehicle with plug located on vehicle side

Figure 1a

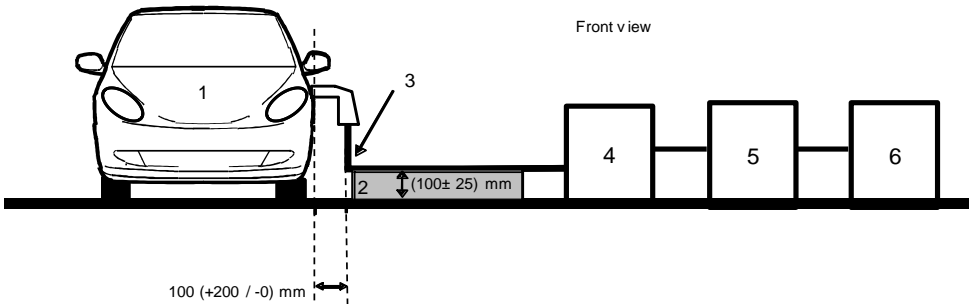
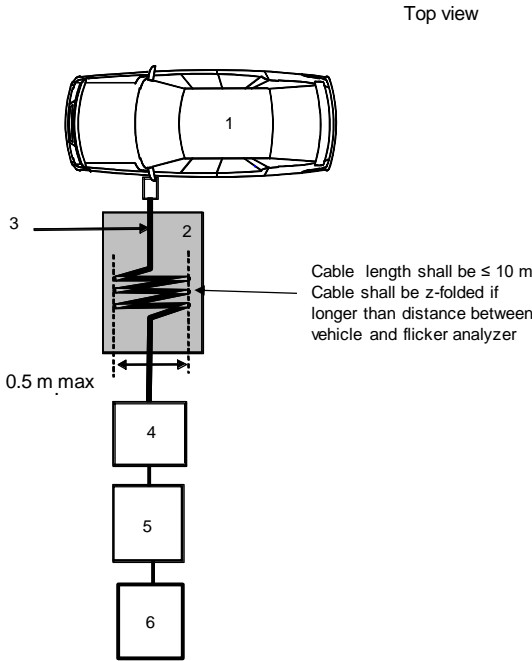

Figure 1b



Legend:

- 1** Vehicle under test
- 2** Insulating support
- 3** Charging cable
- 4** Flicker analyzer
- 5** Impedance simulator
- 6** Power supply

Example of test setup for vehicle with plug located front/rear of vehicle

Figure 1c

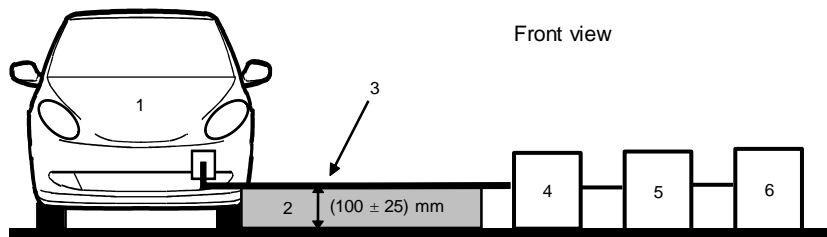
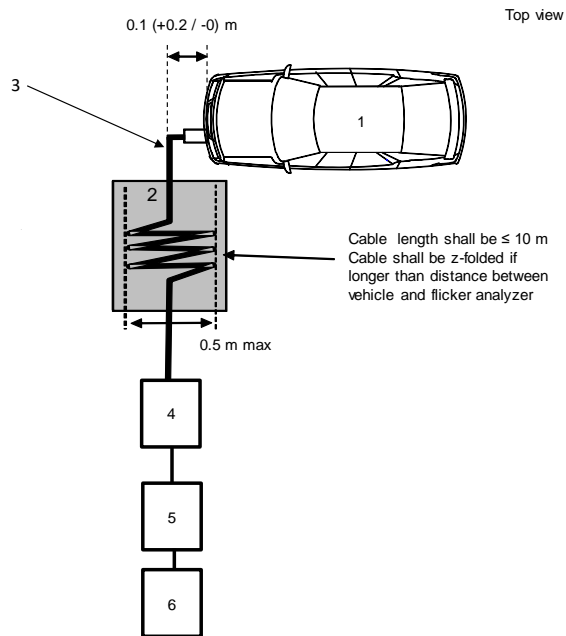

Figure 1d



Legend:

- 1** Vehicle under test
- 2** Insulating support
- 3** Charging cable

- 4 **Flicker analyzer**
- 5 **Impedance simulator**
- 6 **Power supply ”**

Annex 13,

Paragraph 2.1., amend to read:

“2.1. The vehicle shall be in configuration "REESS charging mode coupled to the power grid".

The state of charge (SOC) of the traction battery shall be kept between 20 per cent and 80 per cent of the maximum SOC during the whole frequency range measurement (this may lead to splitting the measurement in different sub-bands with the need to discharge the vehicle's traction battery before starting the next sub-bands). ~~If the current consumption can be adjusted, then the current shall be set to at least 80 per cent of its nominal value.~~

If the current consumption can be adjusted, then the current shall be set to at least 80 per cent of its nominal value for AC charging.

If the current consumption can be adjusted, then the current shall be set to at least 80 per cent of its nominal value for DC charging unless another value is agreed with the type approval authorities.

In case of multiple batteries the average state of charge must be considered.

~~The vehicle shall be immobilized, engine OFF.~~

~~And all other equipment which can be switched on permanently by the driver or passenger should be OFF.~~

The vehicle shall be immobilized, the engine(s) (ICE and / or electrical engine) shall be OFF and in charging mode.

All other equipment which can be switched ON by the driver or passengers shall be OFF.”

Insert a new paragraph 3.2, to read:

“3.2. **Measuring location**

A shielded enclosure or an absorber lined shielded enclosure (ALSE) or an open area test site (OATS) which complies with the requirements of CISPR 16-1-4 may be used.”

Paragraph 3.2.(old) , renumber as 3.3. and amend to read:

“3.2.3. The artificial ~~mains~~-network(s) to be used for the measurement on vehicle ~~is~~ **are**

(a) the AMN(s) defined in paragraph 4.3. of CISPR 16-1-2 for AC power lines

(b) the DC-charging-AN(s) defined in appendix 8 for DC power lines

Artificial networks

The AN(~~s~~) **AMN(s)/DC-charging-AN(s)** shall be mounted directly on the ground plane. The cases of the AN(~~s~~) **AMN(s)/DC-charging-AN(s)** shall be bonded to the ground plane.

~~The measuring port of the AN shall be terminated with a 50 Ω load.~~

The conducted emissions on AC and DC power lines are measured successively on each power line by connecting the measuring receiver on the measuring port of the related AMN/DC-charging-AN. The measuring port of the AMN/DC-charging-AN inserted in the other power line shall be terminated with a 50 Ω load.

The AN-AMN(s)/DC-charging-AN(s) shall be placed as defined in Figures 1a to 1d. of Appendix 1 to this annex.”

Paragraphs 3.3. to 3.4., renumber as 3.4. to 3.5.

Paragraph 4.1., amend to read:

“4.1. The limits apply throughout the frequency range 0.15 to 30 MHz for measurements performed in ~~a semi-anechoic chamber~~ **a shielded enclosure or an absorber lined shielded enclosure (ALSE)** or ~~an outdoor test site~~ **an open area test site (OATS).**”

Annex 13, Appendix 1, amend to read:

“Annex 13 - Appendix 1

Figure 1

Vehicle in configuration "REESS charging mode coupled to the power grid"

Example of test setup for vehicle with plug located on vehicle side (AC powered without communication)

Figure 1a

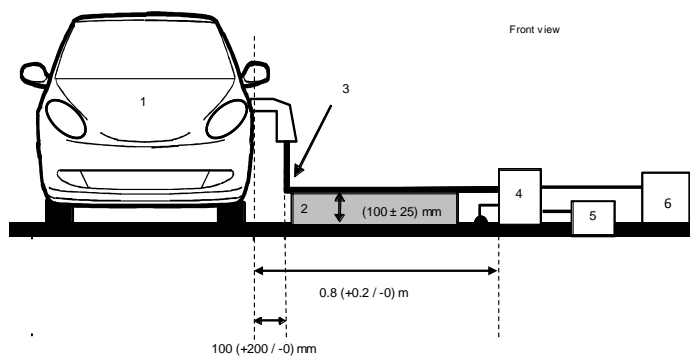
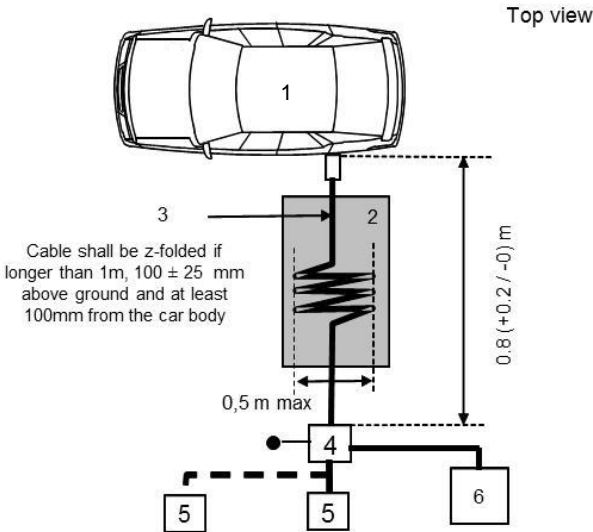

Figure1b



Legend:

- 1 Vehicle under test
- 2 Insulating support
- 3 Charging cable
- 4 AMN(s) or DC-charging-AN(s) grounded
- 5 Power mains socket
- 6 Measuring receiver

Vehicle in configuration "REESS charging mode coupled to the power grid"

Example of test setup for vehicle with plug located front / rear of vehicle (AC powered without communication)

Figure 1c

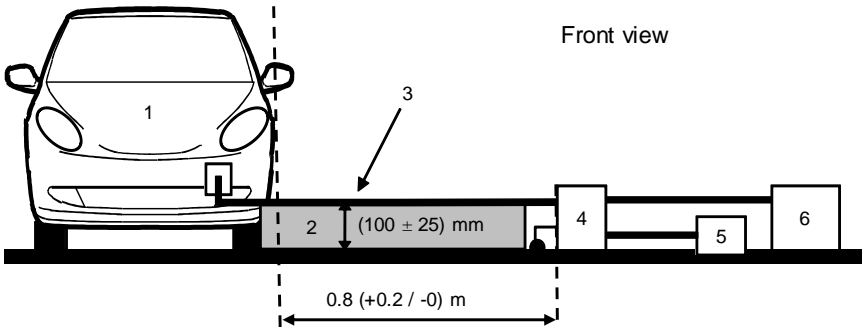
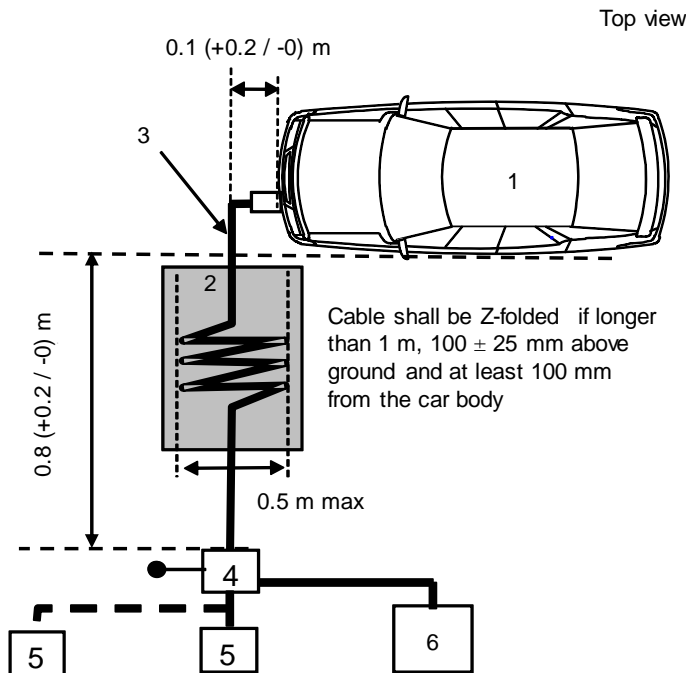

Figure 1d



Legend:

- 1 Vehicle under test
- 2 Insulating support
- 3 Charging cable
- 4 AMN(s) or DC-charging-AN(s) grounded
- 5 Power mains socket
- 6 Measuring receiver

Annex 14,

Paragraph 2.1., amend to read:

“2.1. The vehicle shall be in configuration "REESS charging mode coupled to the power grid". The state of charge (SOC) of the traction battery shall be kept between 20 per cent and 80 per cent of the maximum SOC during the whole frequency range measurement (this may lead to splitting the measurement in different sub-bands with the need to discharge the vehicle's traction battery before starting the next sub-bands). ~~If the current consumption can be adjusted, then the current shall be set to at least 80 per cent of its nominal value.~~

If the current consumption can be adjusted, then the current shall be set to at least 80 per cent of its nominal value for AC charging.

If the current consumption can be adjusted, then the current shall be set to at least 80 per cent of its nominal value for DC charging unless another value is agreed with the type approval authorities.

In case of multiple batteries the average state of charge must be considered.

~~The vehicle shall be immobilized, engine OFF.~~

And all other equipment which can be switched on permanently by the driver or passenger should be OFF.

The vehicle shall be immobilized, the engine(s) (ICE and / or electrical engine) shall be OFF and in charging mode.

All other equipment which can be switched ON by the driver or passengers shall be OFF.”

Insert a new paragraph 3.2. to read:

“3.2. Measuring location

A shielded enclosure or an absorber lined shielded enclosure (ALSE) or an open area test site (OATS) which complies with the requirements of CISPR 16-1-4 may be used.”

Paragraphs 3.2. to 3.4., renumber as 3.3. to 3.5.

Paragraph 4.1., amend to read:

“4.1. The limits apply throughout the frequency range 0.15 to 30 MHz for measurements performed in ~~a semi-anechoic chamber~~ **a shielded enclosure or an absorber lined shielded enclosure (ALSE) or an outdoor test site** ~~an open area test site (OATS).~~”

Annex 14, Appendix 1, delete and replace by:

"Annex 14 – Appendix 1

Figure 1

Vehicle in configuration "REESS charging mode coupled to the power grid"

Example of test setup for vehicle with plug located on vehicle side (AC or DC powered with communication)

Figure 1a

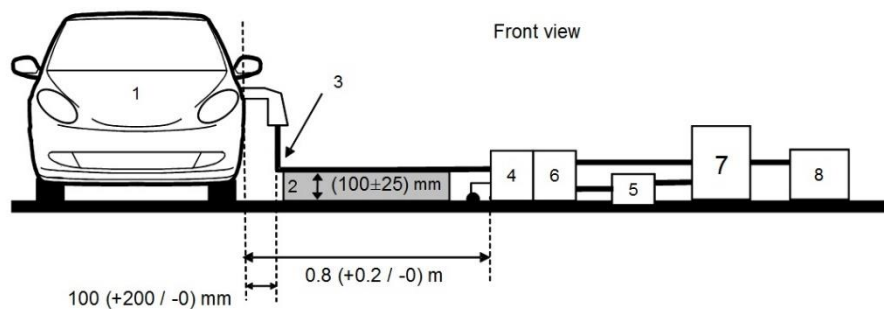
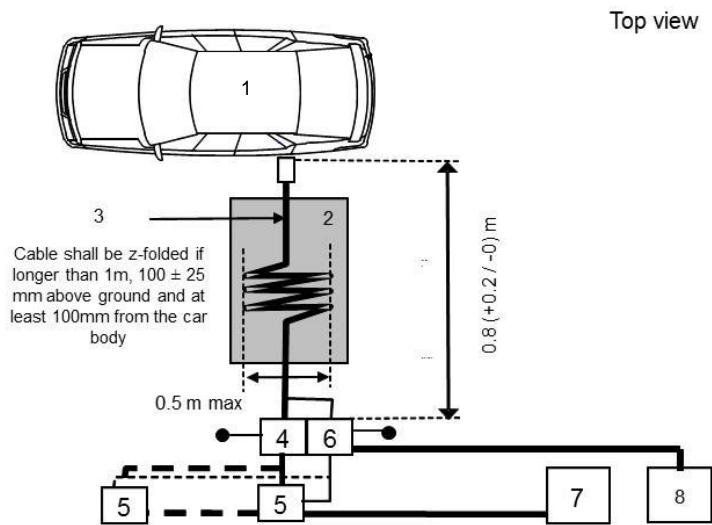

Figure 1b



Legend:

- | | | | |
|---|--------------------------------------|---|---|
| 1 | Vehicle under test | 5 | Power mains socket |
| 2 | Insulating support | 6 | Impedance stabilization(s) grounded (for communication lines) |
| 3 | Charging / communication cable | 7 | Charging station |
| 4 | AMN(s) or DC-charging-AN(s) grounded | 8 | Measuring receiver |

Vehicle in configuration "REESS charging mode coupled to the power grid"

Example of test set-up for vehicle with plug located front/rear of vehicle (AC or DC powered with communication)

Figure 1c

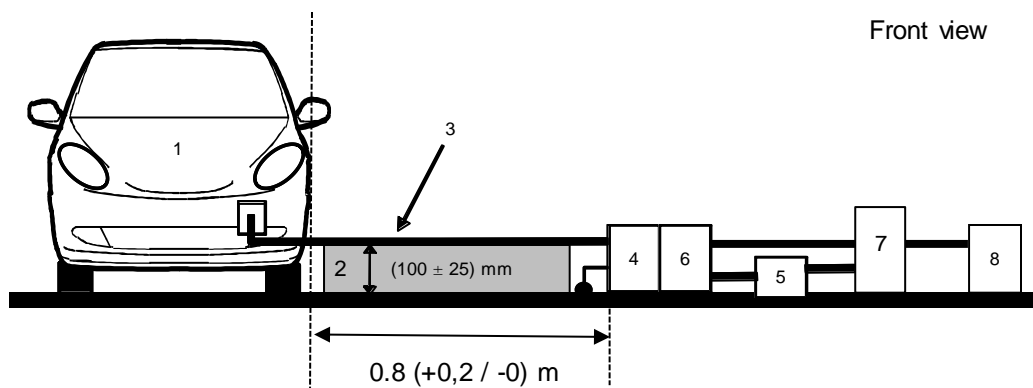
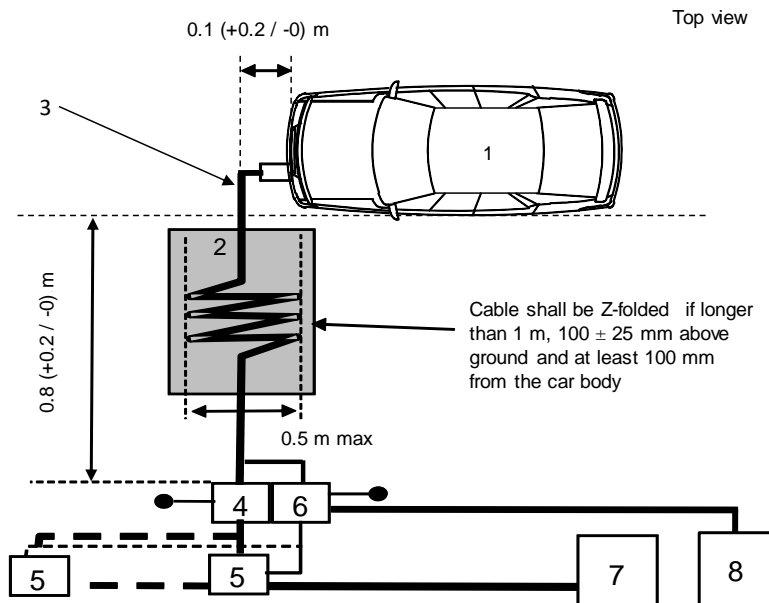

Figure 1d



Legend:

- | | | | |
|---|--------------------------------------|---|---|
| 1 | Vehicle under test | 5 | Power mains socket |
| 2 | Insulating support | 6 | Impedance stabilization(s) grounded (for communication lines) |
| 3 | Charging / communication cable | 7 | Charging station |
| 4 | AMN(s) or DC-charging-AN(s) grounded | 8 | Measuring receiver |

Figure 2
Alternative measurement for vehicle in configuration "REESS charging mode coupled in the power grid"

Example of test setup for vehicle with plug located on vehicle side (AC or DC powered with communication)

Figure 2a

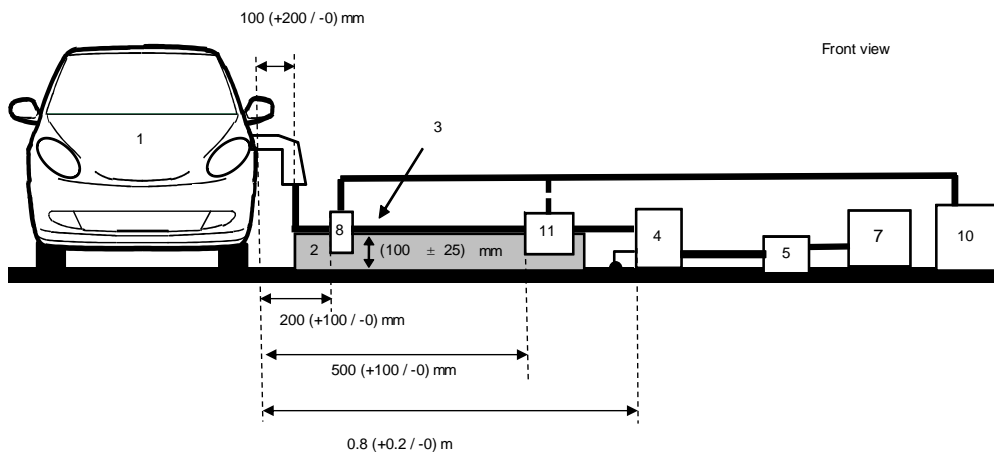
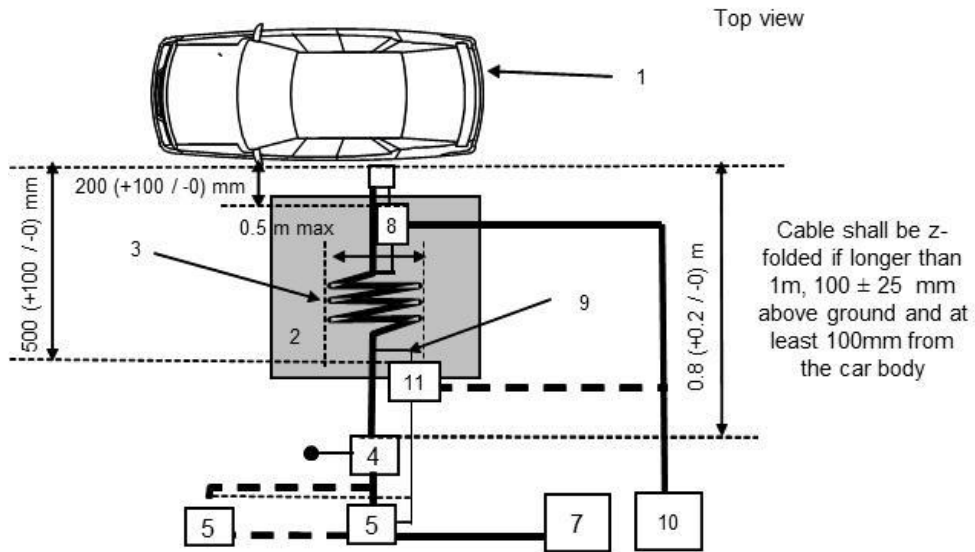

Figure 2b



Legend:

- | | | | |
|---|--------------------------------------|----|--------------------------|
| 1 | Vehicle under test | 7 | Charging station |
| 2 | Insulating support | 8 | Current probe |
| 3 | Charging / communication cable | 9 | Communication lines |
| 4 | AMN(s) or DC-charging-AN(s) grounded | 10 | Measuring receiver |
| 5 | Power mains socket | 11 | Capacitive voltage probe |

Alternative measurement for vehicle in configuration "REESS charging mode coupled in the power grid"

Example of test setup for vehicle with plug located front / rear of vehicle (AC or DC powered with communication)

Figure 2c

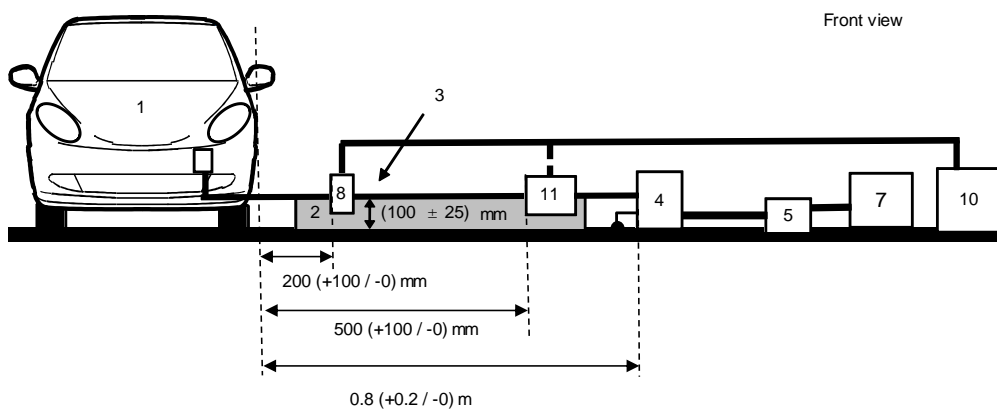
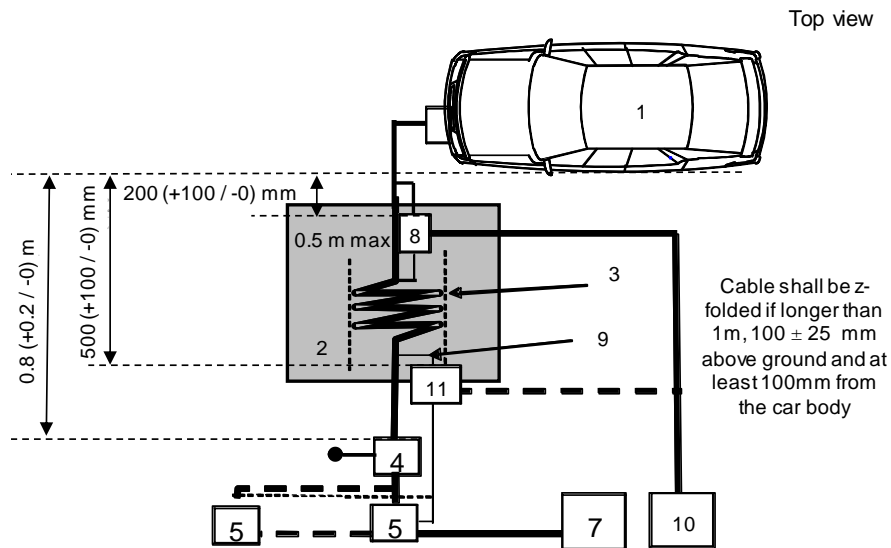

Figure 2d



Legend:

1	Vehicle under test	7	Charging station
2	Insulating support	8	Current probe (or capacitive voltage probe)
3	Charging / communication cable	9	Communication lines
4	AMN(s) or DC-charging-AN(s) grounded	10	Measuring receiver
5	Power mains socket	11	Capacitive voltage probe

Annex 15,

Paragraph 2.1.1., amend to read:

“2.1.1. ~~The vehicle shall be immobilized, engine OFF and in charging mode.~~

The vehicle shall be immobilized, the engine(s) (ICE and / or electrical engine) shall be OFF and in charging mode.”

Paragraph 2.1.2., amend to read:

“2.1.2. Basic vehicle conditions

The paragraph defines minimum test conditions (as far as applicable) and failures criteria for vehicle immunity tests. Other vehicle systems, which can affect immunity related functions, shall be tested in a way to be agreed between manufacturer and Technical Service.

<i>"REESS charging mode" vehicle test conditions</i>	<i>Failure criteria</i>
<p>The REESS shall be in charging mode. The state of charge (SOC) of the traction battery shall be kept between 20 per cent and 80 per cent of the maximum SOC during the whole time duration of the measurement (this may lead to the measurement being split into different time slots with the need to discharge the vehicle's traction battery before starting the next time slot). If the current consumption can be adjusted, then the current shall be set to at least 20 per cent of its nominal value.</p> <p>In case of multiple batteries the average state of charge must be considered.</p>	<p>Vehicle sets in motion</p>

”

Paragraph 2.1.3., amend to read:

“2.1.3. ~~All other equipment which can be switched on permanently by the driver or passenger should be OFF.~~

All other equipment which can be switched ON by the driver or passengers shall be OFF.”

Paragraph 4.3., amend to read:

“4.3. The Technical Service shall perform the test as specified in paragraph ~~7.7.2.1.~~ **7.8.2.1.** of this Regulation.

Alternatively, if the manufacturer provides measurement from a test laboratory accredited to the applicable parts of ISO 17025 and recognized by the Type Approval Authority, the Technical Service may choose not to perform the test to confirm that the vehicle meets the requirements of this annex.”

Paragraph 5.1.2., amend to read:

“5.1.2. Test phase

The vehicle shall be positioned on the ground plane. The electrical fast transient/burst (EFT/B) shall be applied on the vehicle on the AC/DC power lines in common modes by using CDN as described in Figure **1a to 1d** of Appendix 1 to this annex.

The test set-up shall be noted in the test report.”

Annex 15, Appendix 1, amend to read:

“Annex 15 - Appendix 1

Figure 1
Vehicle in configuration "REESS charging mode coupled to the power grid"
Example of test setup for vehicle with plug located on vehicle side

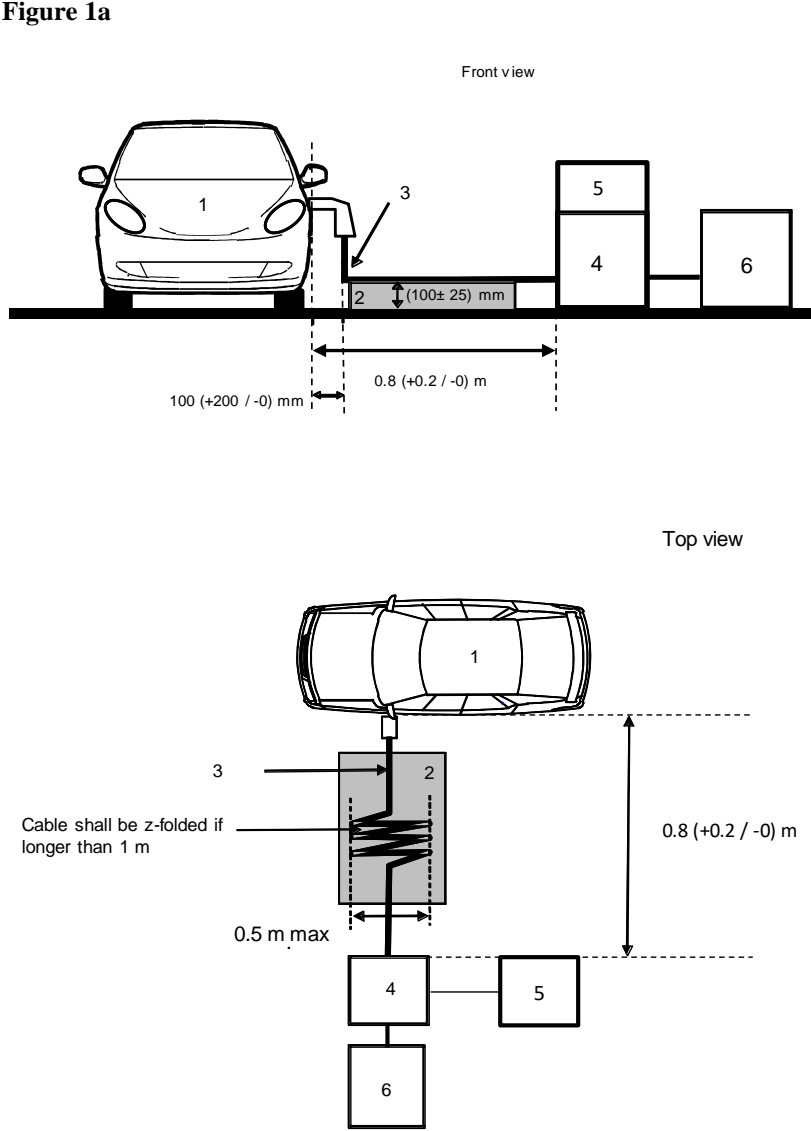

Legend:

- 1 Vehicle under test
- 2 Insulating support
- 3 Charging cable
- 4 CDN
- 5 Fast Transients / Burst generator
- 6 Power supply

Example of test setup for vehicle with plug located front/rear of vehicle

Figure 1c

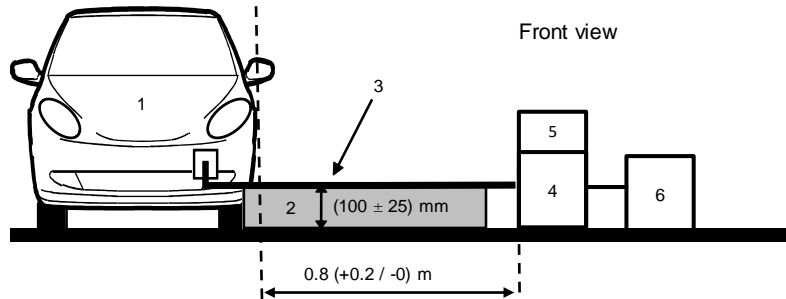
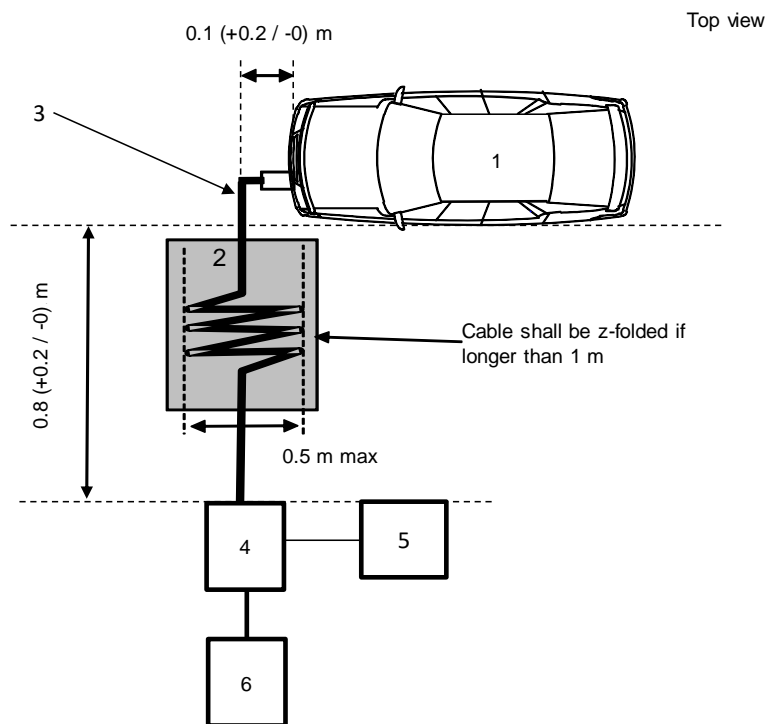

Figure 1d



Legend:

- 1 Vehicle under test
- 2 Insulating support
- 3 Charging cable
- 4 CDN
- 5 Fast Transients / Burst generator
- 6 Power supply

Annex 16,

Paragraph 1.2., amend to read:

“1.2. Test method

This test is intended to demonstrate the immunity of the vehicle electronic systems. The vehicle shall be subject to surges conducted along AC and DC power lines of the vehicle as described in this annex. The vehicle shall be monitored during the tests.

If not otherwise stated in this annex the test shall be performed according to IEC 61000-4-5 **for lightning transients (clause 4.2).**”

Paragraph 2.1.1., amend to read:

“2.1.1. ~~The vehicle shall be immobilized, engine OFF and in charging mode.~~

The vehicle shall be immobilized, the engine(s) (ICE and / or electrical engine) shall be OFF and in charging mode.”

Paragraph 2.1.2., amend to read:

“2.1.2. Basic vehicle conditions

The paragraph defines minimum test conditions (as far as applicable) and failures criteria for vehicle immunity tests. Other vehicle systems, which can affect immunity related functions, shall be tested in a way to be agreed between manufacturer and Technical Service.

<i>"REESS charging mode" vehicle test conditions</i>	<i>Failure criteria</i>
<p>The REESS shall be in charging mode. The state of charge (SOC) of the traction battery shall be kept between 20 per cent and 80 per cent of the maximum SOC during the whole time duration of the measurement (this may lead to the measurement being split into different time slots with the need to discharge the vehicle's traction battery before starting the next time slot).. If the current consumption can be adjusted, then the current shall be set to at least 20 per cent of its nominal value.</p> <p>In case of multiple batteries the average state of charge must be considered.</p>	<p>Vehicle sets in motion</p>

”

Paragraph 2.1.3., amend to read:

“2.1.3. ~~All other equipment which can be switched on permanently by the driver or passenger should be OFF.~~

All other equipment which can be switched ON by the driver or passengers shall be OFF.”

Paragraph 4.3., amend to read:

“4.3. The Technical Service shall perform the test as specified in paragraph ~~7.8.2.1.~~ **7.9.2.1.** of this Regulation.”

Paragraph 5.1.2., amend to read:

“5.1.2. Test phase

The vehicle shall be positioned on the ground plane. The electrical surge shall be applied on the vehicle on the AC/DC power lines between each line and earth and between lines by using CDN as described in Figures **1a** to **1d** of Appendix 1 to this annex,

The test setup shall be noted in the test report.”

Annex 16, Appendix 1, amend to read:

“Annex 16 - Appendix 1

Vehicle in configuration "REESS charging mode coupled to the power grid"

Figure 1

Vehicle in configuration "REESS charging mode coupled to the power grid"

Example of test setup for vehicle with plug located on vehicle side

Figure 1a

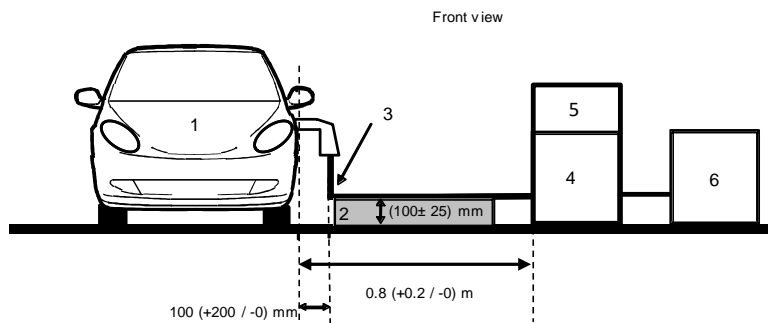
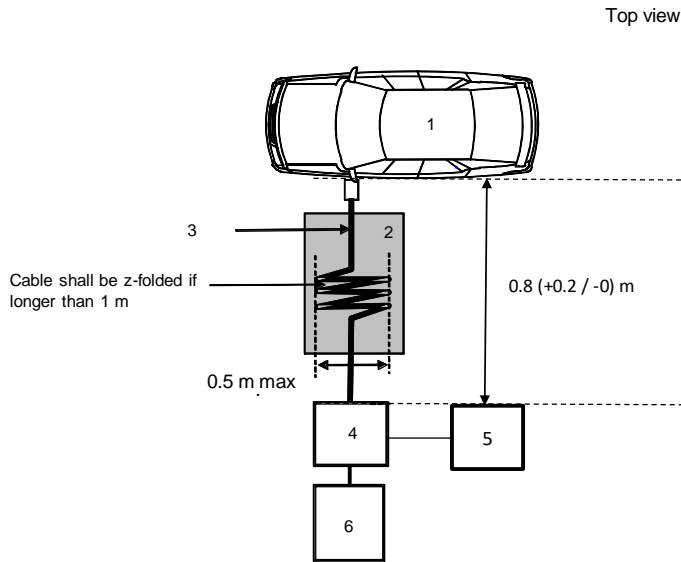

Figure 1b



Legend:

- 1 Vehicle under test
- 2 Insulating support
- 3 Charging cable
- 4 CDN
- 5 Surge generator
- 6 Power supply

Example of test setup for vehicle with plug located front/rear of vehicle

Figure 1c

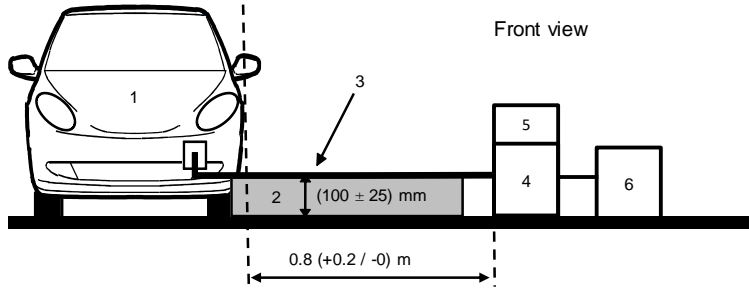
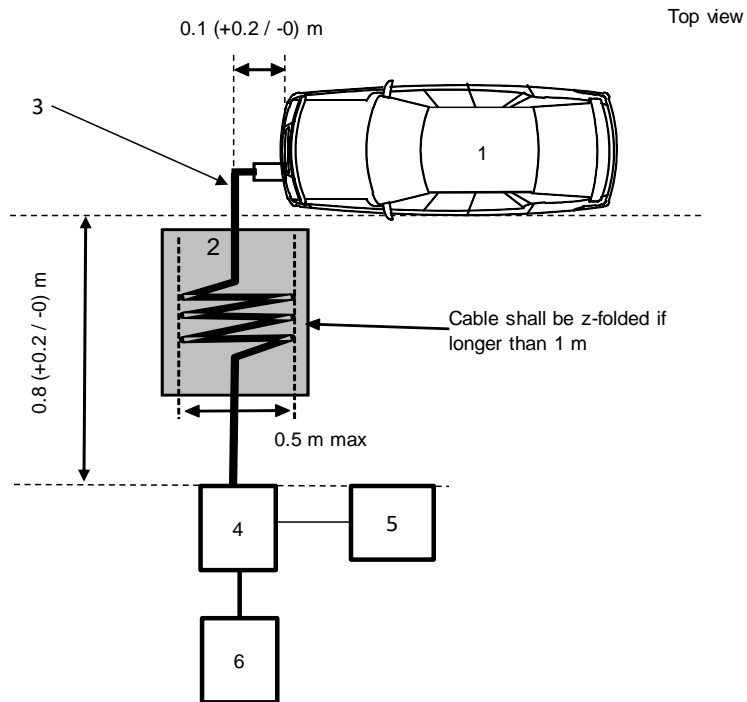

Figure 1d



Legend:

- 1 Vehicle under test
- 2 Insulating support
- 3 Charging cable
- 4 CDN
- 5 Surge generator
- 6 Power supply

Annex 17, paragraph 2.1., amend to read:

“2.1. The ESA shall be in configuration "REESS charging mode coupled to the power grid".

The state of charge (SOC) of the traction battery shall be kept between 20 per cent and 80 per cent of the maximum SOC during the whole time duration of the measurement (this may lead to the measurement being split into different time slots with the need to discharge the vehicle's traction battery before starting the next time slot).

If the current consumption can be adjusted, then the current shall be set to at least 80 per cent of its nominal value **for AC charging.**“

Annex 18, paragraph 2.1., amend to read:

“2.1. The ESA shall be in configuration "REESS charging mode coupled to the power grid".

The state of charge (SOC) of the traction battery shall be kept between 20 per cent and 80 per cent of the maximum SOC during the whole time duration of the measurement (this may lead to the measurement being split into different time slots with the need to discharge the vehicle's traction battery before starting the next time slot).

If the current consumption can be adjusted, then the current shall be set to at least 80 per cent of its nominal value **for AC charging.**“

Annex 19,

Paragraph 2.1., amend to read:

“2.1. The ESA shall be in configuration "REESS charging mode coupled to the power grid".

The state of charge (SOC) of the traction battery shall be kept between 20 per cent and 80 per cent of the maximum SOC during the whole frequency range measurement (this may lead to split the measurement in different sub-bands with the need to discharge the vehicle's traction battery before starting the next sub-bands).

If the test is not performed with a REESS the ESA should be tested at rated current. ~~If the current consumption can be adjusted, then the current shall be set to at least 80 per cent of its nominal value.~~

If the current consumption can be adjusted, then the current shall be set to at least 80 per cent of its nominal value for AC charging.

If the current consumption can be adjusted, then the current shall be set to at least 80 per cent of its nominal value for DC charging unless another value is agreed with the type approval authorities.”

Paragraph 3.1., delete.

Paragraph 3.2., renumber as 3.1. and amend to read:

“~~3.2.1.~~ The artificial ~~main~~-network(s) to be used for the measurement on vehicle ~~is~~ **are**

(a) **the AMN(s) defined in paragraph 4.3. of CISPR 16-1-2 for AC power lines**

(b) **the DC-charging-AN(s) defined in appendix 8 for DC power lines**

Artificial networks

The ~~AN(s)~~ **AMN(s)/DC-charging-AN(s)** shall be mounted directly on the ground plane. The cases of the ~~AN(s)~~ **AMN(s)/DC-charging-AN(s)** shall be bonded to the ground plane.

The conducted emissions on AC and DC power lines are measured successively on each power line by connecting the measuring receiver on the measuring port of the related ~~AN-AMN/DC-charging-AN~~. The measuring port of the ~~AN-AMN/DC-charging-AN~~ inserted in the other power lines ~~being shall be~~ terminated with a 50 Ω load.

The ~~AN~~ **AMN(s)/DC-charging-AN(s)** shall be placed in front, aligned and on the same side of the vehicle power charging plug.”

Insert a new paragraph 3.2.to read:

“3.2. Measuring location

A shielded enclosure or an absorber lined shielded enclosure (ALSE) or an open area test site (OATS) which complies with the requirements of CISPR 16-1-4 may be used. “

Paragraph 3.3., amend to read:

“3.3. The test set-up (**floor-standing equipment**) for the connection of the ESAs in configuration "REESS charging mode coupled to the power grid" is shown in Figure 1 of Appendix 1 to this annex.”

Paragraph 3.4., amend to read:

“3.4. The measurements shall be performed with a spectrum analyser or a scanning receiver. The parameters to be used are defined in Table 1 and Table 2.

Table 1
Spectrum analyser parameters

Frequency range MHz	Peak detector		Quasi-peak detector		Average detector	
	RBW at -3 dB	Scan time	RBW at -6 dB	Scan time	RBW at -3 dB	Scan time
0.15 to 30	9/10 kHz	10 s/MHz	9 kHz	200 s/MHz	9/10 kHz	10 s/MHz

Note: If a spectrum analyser is used for peak measurements, the video bandwidth shall be at least three times the resolution bandwidth (RBW)

Table 2
Scanning receiver parameters

Frequency range MHz	Peak detector			Quasi-peak detector			Average detector		
	BW at -6 dB	Step size ^a	Dwell time	BW at -6 dB	Step size ^a	Dwell time	BW at -6 dB	Step size ^a	Dwell time
0.15 to 30	9 kHz	5 kHz	50 ms	9 kHz	5 kHz	1 s	9 kHz	5 kHz	50 ms

~~^a For purely broadband disturbances, the maximum frequency step size may be increased up to a value not greater than the bandwidth value.~~

Note: For emissions generated by brush commutator motors without an electronic control unit, the maximum step size may be increased up to five times the bandwidth.”

Paragraph 4.1., amend to read:

“4.1 The limits apply throughout the frequency range 0.15 to 30 MHz for measurements performed in ~~a semi-anechoic chamber~~ **a shielded enclosure or an absorber lined shielded enclosure (ALSE) or an outdoor test sites open area test site (OATS).**”

Annex 19, Appendix 1, amend to read:

“Annex 19 – Appendix 1

Figure 1
ESA in configuration "REESS charging mode coupled to the power grid" (floor-standing equipment)

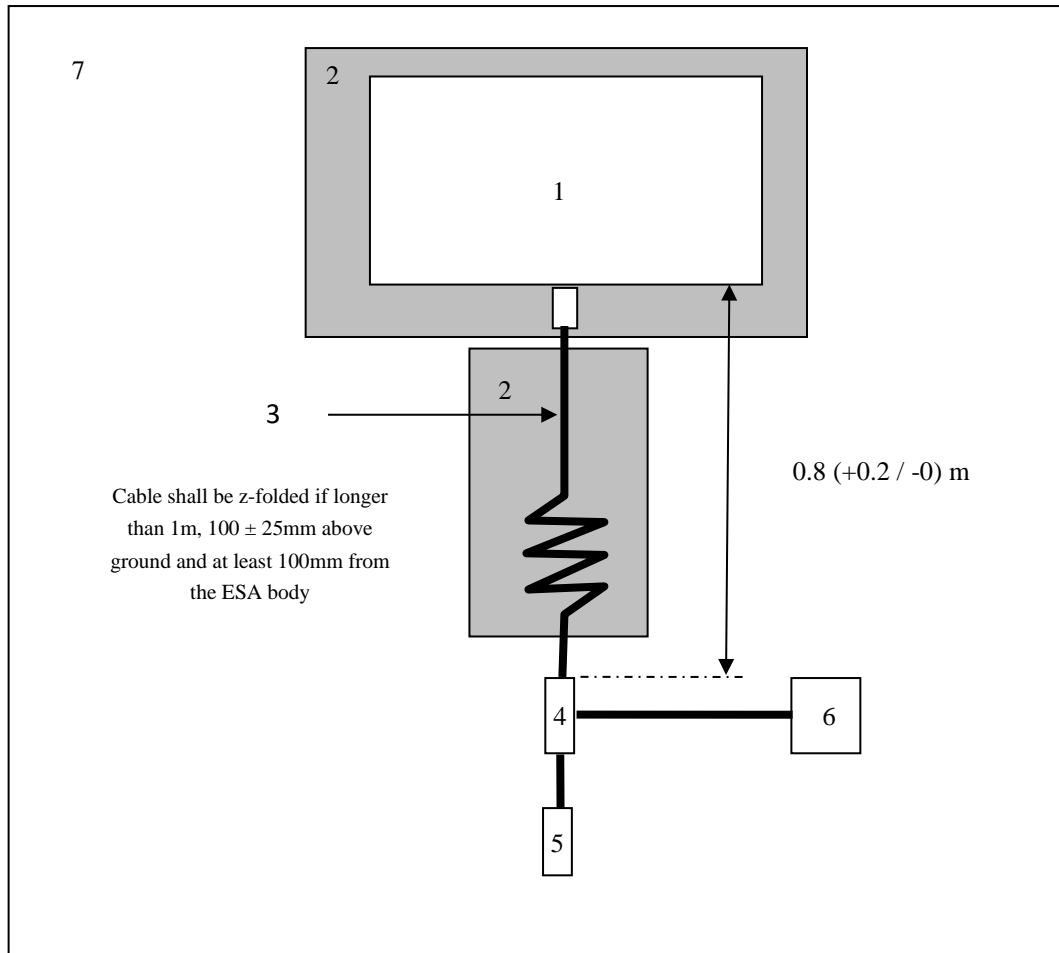

Legend:

- 1 ESA under test
- 2 Insulating support
- 3 Charging cable
- 4 AMN(s) or DC-charging-AN(s) grounded
- 5 Power mains socket
- 6 Measuring receiver
- 7 Ground plane

Annex 20,

Paragraph 2.1., amend to read:

“2.1. The ESA shall be in configuration "REESS charging mode coupled to the power grid".

The state of charge (SOC) of the traction battery shall be kept between 20 per cent and 80 per cent of the maximum SOC during the whole frequency range measurement (this may lead to split the measurement in different sub-bands with the need to discharge the vehicle's traction battery before starting the next sub-bands).

If the test is not performed with a REESS the ESA should be tested at rated current. ~~If the current consumption can be adjusted, then the current shall be set to at least 80 per cent of its nominal value.~~

If the current consumption can be adjusted, then the current shall be set to at least 80 per cent of its nominal value for AC charging.

If the current consumption can be adjusted, then the current shall be set to at least 80 per cent of its nominal value for DC charging unless another value is agreed with the type approval authorities. “

Paragraph 3.1., delete.

Paragraph 3.2., renumber as 3.1.

Insert a new paragraph 3.2. to read:

“3.2. **Measuring location**

A shielded enclosure or an absorber lined shielded enclosure (ALSE) or an open area test site (OATS) which complies with the requirements of CISPR 16-1-4 may be used. “

Paragraph 3.3., amend to read:

“3.3. The test set-up (**floor-standing equipment**) for the connection of the ESA in configuration "REESS charging mode coupled to the power grid" is shown in Figure 1 of Appendix 1 to this annex.”

Paragraph 3.4., amend to read:

“3.4. The measurements shall be performed with a spectrum analyser or a scanning receiver. The parameters to be used are defined in Table 1 and Table 2.

Table 1
Spectrum analyser parameters

Frequency range MHz	Peak detector		Quasi-peak detector		Average detector	
	RBW at -3 dB	Scan time	RBW at -6 dB	Scan time	RBW at -3 dB	Scan time
0.15 to 30	9/10 kHz	10 s/MHz	9 kHz	200 s/MHz	9/10 kHz	10 s/MHz

Note:

If a spectrum analyser is used for peak measurements, the video bandwidth shall be at least three times the resolution bandwidth (RBW).

Table 2
Scanning receiver parameters

Frequency range MHz	Peak detector			Quasi-peak detector			Average detector		
	BW at -6 dB	Step size [#]	Dwell time	BW at -6 dB	Step size [#]	Dwell time	BW at -6 dB	Step size [#]	Dwell time
0.15 to 30	9 kHz	5 kHz	50 ms	9 kHz	5 kHz	1 s	9 kHz	5 kHz	50 ms

[#] ~~For purely broadband disturbances, the maximum frequency step size may be increased up to a value not greater than the bandwidth value.”~~

Paragraph 4.1., amend to read:

“4.1. The limits apply throughout the frequency range 0.15 to 30 MHz for measurements performed in ~~a semi-anechoic chamber~~ **a shielded enclosure or an absorber lined shielded enclosure (ALSE)** or an ~~outdoor test sites~~ **open area test site (OATS).**”

Annex 20, Appendix 1, delete and replace by:

“Annex 20 – Appendix 1

Figure 1
ESA in configuration "REESS charging mode coupled to the power grid" (floor-standing equipment)

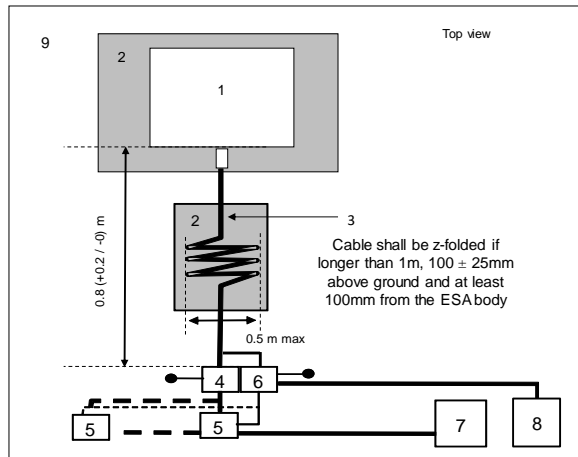

Legend:

- 1 **ESA under test**
- 2 **Insulating support**
- 3 **Charging / communication cable**
- 4 **AMN(s) or DC-charging-AN(s) grounded**
- 5 **Power mains socket**
- 6 **Impedance stabilization(s) grounded**
- 7 **Charging station**
- 8 **Measuring receiver**
- 9 **Ground plane”**

II. Justification

1. Clause 3.1.9. was added to the 04 series of amendments to Regulation No. 10, because there had been no description of the rechargeable energy storage system (REESS) equipment electrical sub-assembly (ESA) tests and, therefore, these specific REESS tests could only be performed at the vehicle level. When the 05 series of amendments to Regulation No. 10 was adopted, including the specific REESS-equipment ESA test, clause 3.1.9. should have been deleted.

2. The 05 series of amendments vehicle broadband reference limits (at 3 m and 10 m) are consistent with the CISPR 12 broadband reference limits (at 3 m and 10 m), while the 05 series of amendments vehicle narrowband reference limits (at 3 m and 10 m) are not consistent with those from CISPR 12. Thus, it is proposed to have the 06 series of amendments vehicle narrowband reference limits (at 3 m and 10 m) consistent with the CISPR 12 narrowband ones (the CISPR12 narrowband limit minus 2 dB as a more stringent requirement for type approval, as defined in CISPR 12).

3. The updates of artificial(s) network(s) (AN) are consistent with the last updates in CISPR 12 and CISPR 25 with use of artificial mains networks (AMN) for AC mains, “DC-charging-AN” for DC mains and high voltage (HV) AN for HV ESA.

4. Additional precisions are made concerning limits of the International Electrotechnical Commission (IEC) standards IEC 61000-3-3, paragraph 5 and IEC 61000-3-11, paragraph 5 and the associated parameters (Pst, Plt, d(t), ...).
5. Paragraph 7 concerns "Additional specifications in the configuration of the "REESS charging mode coupled to the power grid". For ESAs connected both to low (12V/24V) and high voltages, pulse 4 cannot occur because there is no starter or cranking motor.
6. The proposal includes a precision on "DC network cable" and replaces references to Annexes with references to paragraphs in the body text, because the requirements are laid down in the paragraphs of the main body and not in the Annexes.
7. The proposal for transitional provisions (TPs) includes:
 - Suppression of TPs concerning the 03 and 04 series of amendments (paragraphs 13.1. to 13.10.)
 - replacement of the single TP concerning the 05 series of amendments (paragraph 13.11.) by TPs concerning the 05 series of amendments (paragraph 13.1.1. to 13.1.5.) based on "Draft General Guidelines for United Nations regulatory procedures and transitional provisions in un Regulations" (ECE/TRANS/WP.29/2017/107) using Annex 1 paragraph II "Aide-mémoire" guidelines V.1., V.2. and V.9. for proposed TPs 13.1.1., 13.1.2. and 13.1.5. and consideration of extensions and vehicle types which are not equipped with a coupling system to charge REESS, or component or separate technical unit which does not include a coupling part to charge the REESS for proposed TPs 13.1.3. and 13.1.4.
 - new TPs concerning the 06 series of amendments (paragraph 13.2.1. to 13.2.4.) based on "Draft General Guidelines for United Nations regulatory procedures and transitional provisions in un Regulations" (ECE/TRANS/WP.29/2017/107) using Annex 1 paragraph II "Aide-mémoire" guidelines V.1., V.2. and V.9. for proposed TPs 13.2.1., 13.2.2. and 13.2.4. and consideration of extensions for proposed TP 13.2.3.
8. The document updates references to standards as follows: suppression of reference to ISO 7637-1 (not referred in the document), updates of ISO 11451-2 and ISO 11451-4 to the last edition, corrects ISO 11452-3 (error), update ISO 11452-4 to the last edition, deletes IEC 61000-6-2 (not referred in the document) and update CISPR 16-1-2 to the last edition
9. The HV-AN(s) and DC-charging-AN(s) figures and tables are updated to make them consistent with the last updates in CISPR 12 and CISPR 25.
10. Precisions are made for vehicles in charging mode: minimum current value (with distinction between AC and DC charging, consideration of multiple batteries and vehicle operating mode.
11. Artificial(s) network(s) are updated with use of AMN and DC-charging-AN, precision are done for the harness position and Z-folded portion to make them consistent with the last updates in CISPR 12 and CISPR 25.
12. The state of the art wording is inserted for absorber lined shielded enclosure (ALSE).
13. The figures for the vehicle in charging mode are updated to make them consistent with the last updates in CISPR 12, CISPR 25 and ISO/TC22/SC32/WG3 for the test site, the position of the motorcycle (error) and precision on "extreme hand of handle bar", artificial(s) network(s) are updated with use of AMN and DC-charging-AN, editorial corrections and various configurations (side or front/rear plug) are also introduced.

14. The quasi-peak detector and the sentence on broadband disturbances are deleted, because they do not concern narrowband disturbances measurements.
 15. A precision is made for vehicle operating mode (when not in charging mode).
 16. A change from the facility to vehicle reference point is introduced for consistency with the last ISO 11451-2 update.
 17. A precision is made for vehicle positioning in case of rear irradiation.
 18. A typo in “kHz” is corrected and the sentence concerning broadband disturbances is deleted for consistency with the last CISPR 12 update.
 19. The figures for ESA in charging mode are updated for consistency with the last updates in CISPR 25 and ISO/TC22/SC32/WG3 for artificial(s) network(s) with use of AMN and DC-charging-AN.
 20. A clarification on the ISO 11452-4 test methodology is introduced to make it consistent with the two methodologies defined in the last editions of ISO 11452-4.
 21. The proposal introduces a precision by adding of “three phase” and references to all new figures (1a to 1d).
 22. The two “generic” figures for the vehicle in charging mode are replaced by four detailed figures for the various configurations (side or front/rear plug).
 23. An additional paragraph on “Measuring location” is inserted in Annexes 13, 14, 19 and 20 where this statement was missing.
 24. Additional wording concerning the measurement with a 50 Ω load is inserted.
 25. A clarification is made to reflect the fact that the concerned test in IEC 61000-4-5 is lightning transients.
 26. A precision is inserted that the set-up to be considered is “floor-standing equipment”.
 27. The other corrections are purely editorial.
-