



Actions of the inland transport sector to  
join the global fight against climate change

85<sup>th</sup> Session

**INLAND TRANSPORT COMMITTEE**



**UNECE**

# **2022 achievements of the Working Party on Transport Trends and Economics (WP.5)**

Mrs. Els de Wit  
Chair, WP.5 (NL)  
22 | 02 | 2023, Geneva

# WP.5 clusters of work

## 2022 achievements



- **Cluster 1: Development of transport networks and/ or links**
  - Ongoing EATL operationalization efforts
  - Establishment of a **Corridor Coordination Committee on the Trans-Caspian and Almaty-Istanbul Corridors** (informal Group of Friends of the WP.5 Chair)
- **Cluster 2: Transport and climate change**
  - WP.5/GE.3 Group of Experts on assessment of climate impacts and adaptation for inland transport, covered under **agenda item 7(e)(ii)**
- **Cluster 3: Sustainable urban mobility**
  - Progress report on **Group of Experts on Cycling Infrastructure Module**
  - **WP.5 workshop on electrification of mobility**

# WP.5 clusters of work

## 2022 achievements



- **Cluster 4:** Transport infrastructure data
  - WP.5/GE.4 Group of Experts on benchmarking transport infrastructure construction costs – **FINAL REPORT ADOPTED**
  - International Transport Infrastructure Observatory (ITIO) – **next steps**
- **Cluster 5:** Review and monitoring of emerging issues and sustainable development goals
  - Sustainable Inland Transport Connectivity Indicators (SITCIN) user dashboard – **next steps**
  - Electric vehicle charging infrastructure – **next steps by the Committee and its subsidiary bodies**
- **Cluster 6:** Inland transport security

# Cluster 1- Development of transport networks

## Identifying next steps and priorities



UNECE

- **WP.5 Expert Round Table to take stock of the operational rail capacity of the Trans-Caspian and Almaty-Istanbul corridors** (ECE & ECO secretariat)
- **Participants:** Azerbaijan, Georgia, Iran (Islamic Republic of), Kazakhstan, Türkiye and Uzbekistan
- **Identification of next steps towards establishment of:**
  - Reliable, corridor-wide time time-tables and tariffs/ regular container block trains
  - Efficient, harmonized en route border crossing and customs services
- **Agreed priorities:** digitalization of transport documents, transport infrastructure development, economic viability and resilience

# Cluster 1- Development of transport networks

## Corridor Coordination Committee on Trans-Caspian and Almaty-Istanbul corridors/ Friends of the WP.5 Chair

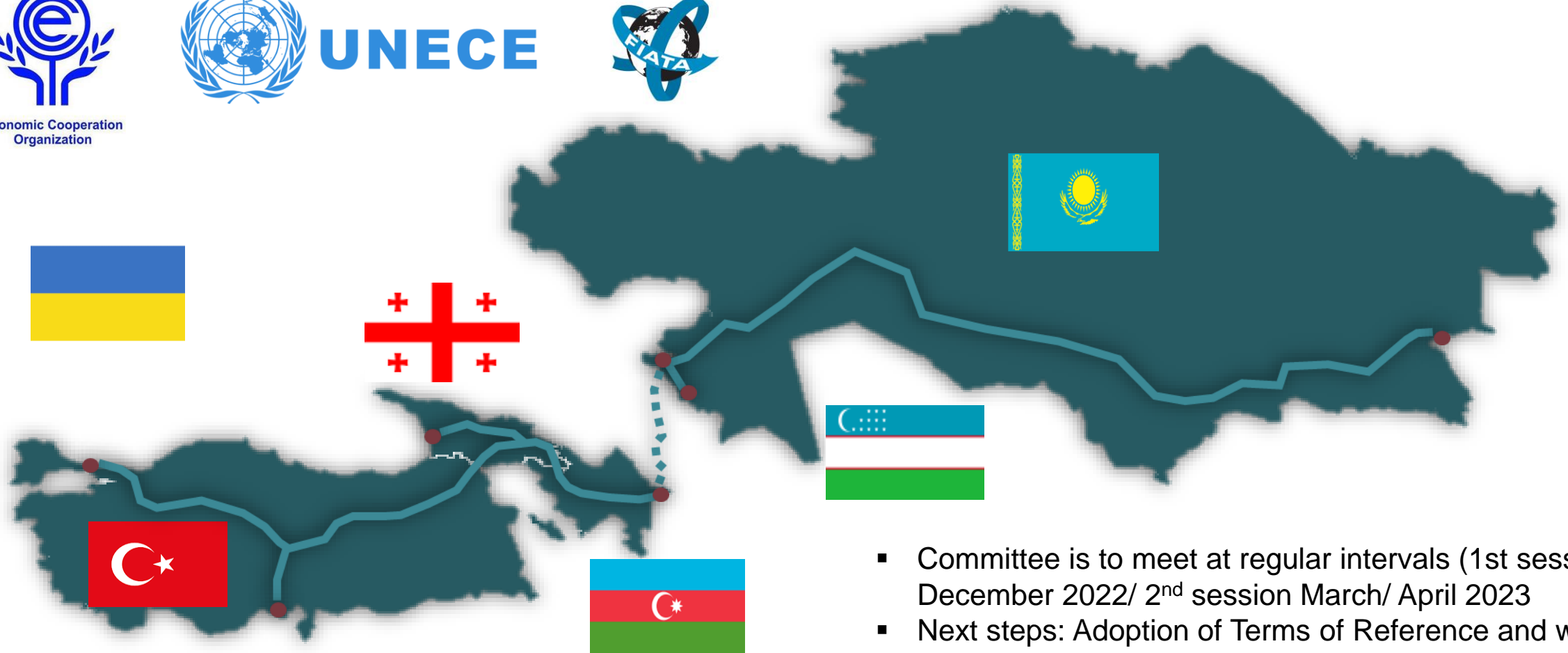

- Committee is to meet at regular intervals (1st session December 2022/ 2<sup>nd</sup> session March/ April 2023)
- Next steps: Adoption of Terms of Reference and work plan, initiation of work

# Cluster 3 – Sustainable urban mobility, public transport and cycling

## Progress of the Group of Experts on Cycling Infrastructure Module (GE.5)



### Priority areas:

- Collection of data on national cycling networks, data analysis and proposal of ECE routes based on existing national routes
- Elaboration of definitions for various types of cycling infrastructure & new road signs which could be used in addition to those in the existing *1968 Convention of road signs and signals*
- GE.5 sessions held in June and November 2022

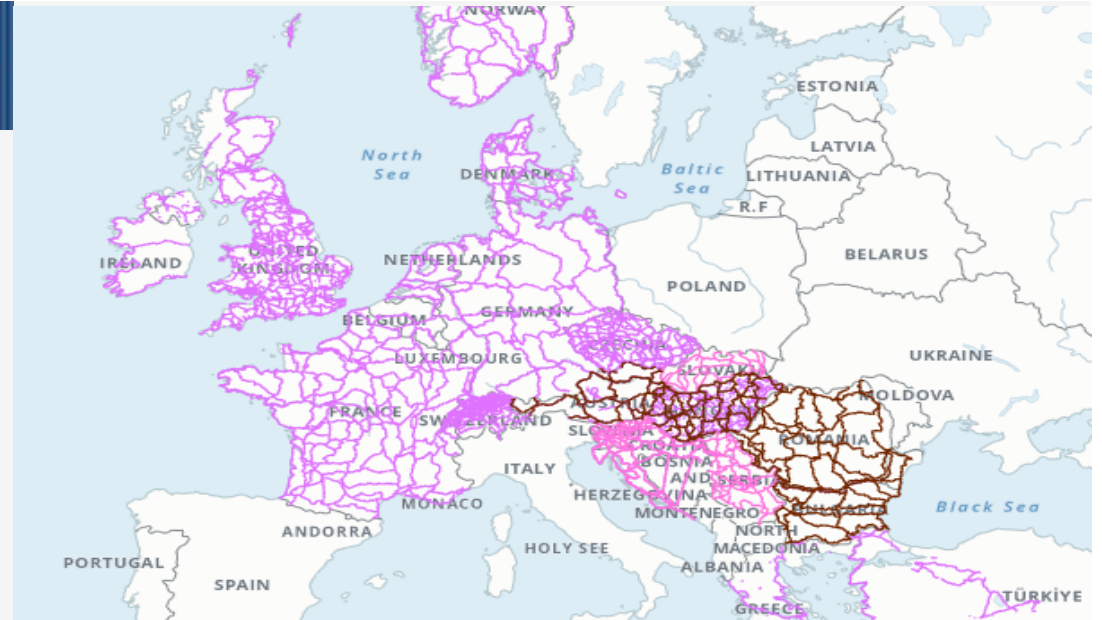

# Cluster 3 – Sustainable urban mobility, public transport and cycling

## Workshop on electrification of mobility, challenges and opportunities for transport, energy and spatial planning



### Proceedings:

- In conjunction with **WP.5 35th session** (SEP 2022)
- **5 UN Regional Commissions**
- **3 ECE divisions:** sustainable transport, energy, housing and land management
- Variety of national speakers, including from **CA, CO, CH, NL, SK, ES, RW, RU, SE, TH, UA** as well as from academia, and partner organizations, i.e. POLIS
- Two-fold focus on **trends in the field of electrification of road vehicles** and resulting **infrastructure needs for transport, energy and spatial planning**



# Cluster 4 – Transport infrastructure data

## GE.4 Group of Experts on Benchmarking of Transport Infrastructure Construction Costs



### Final report adopted at the 35th annual session of WP.5, including:

- A comprehensive **literature review** covering definitions, concepts and methodologies regarding benchmarking of transport **infrastructure construction and maintenance costs**
- A comprehensive **glossary on construction and maintenance terminology** for road, rail, inland waterways, inland ports and inter-modal transport infrastructure
- **A regional benchmarking analysis**, including national data received from stakeholders

### Next steps:

- GE.4 work to be incorporated in TEM/TER projects and ITIO
- UN publication in 3 ECE languages by September 2023





# Cluster 4 – Transport infrastructure data

## International Transport Infrastructure Observatory



Visit us



[ITIO-GIS.org](http://ITIO-GIS.org)

Become a test user



### Progress up-date:

- ITIO contains data from **79 UN MS**/ to be expanded with a **further 27 UN MS** by 2024; **> 20 accredited users** from Government institutions, regional organisations, MDBs etc.
- **ITIO promotion film** available [here](#)
- **ITIO follow-up XB project under preparation** [to improve and expand ITIO functionalities]



# Cluster 5 – Review and monitoring of emerging issues

## Sustainable Inland Transport Connectivity Indicators



### Next steps:

- Upgrading SITCIN.org technical interface/ incl. FR and RU language versions
- Developing tailored SITCIN.org applications, e.g. to measure progress in a specific area: i.e. customs/ border management or for specific country profiles: i.e. LLDCs

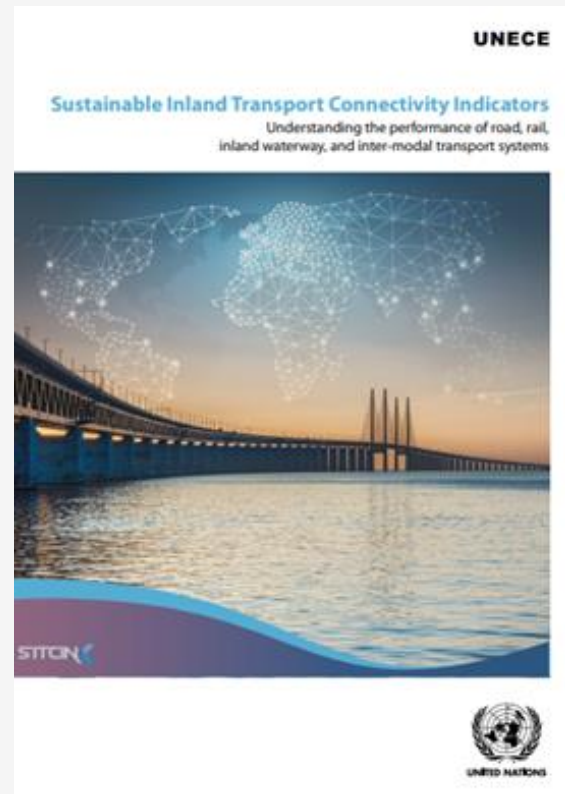

**Publication available!**

Visit us



**SITCIN.org**

**Become a test user**



# Cluster 5 – Review and monitoring of emerging issues

## Electric Vehicle charging infrastructure - mandate



The UNECE Inland Transport Committee at its 84th session requested WP.5:

***“To take into consideration the new trend towards electric charging infrastructure and, in coordination with the chairs of relevant Working Parties, to prepare a first assessment of issues that need addressing in the realm of the Committee to be presented at its eighty-fifth session”***

**[ECE/TRANS/2023/23](#) *[combined effort of Sustainable Transport and Sustainable Energy Divisions]***

# Cluster 5 – Review and monitoring of emerging issues

## Electric Vehicle charging infrastructure – OUTLINE I



### I. Mandate

### II. Trends of importance to determine future transport demand

- A. Introduction
- B. Trends in passenger road transport
- C. Trends in road freight transport
- D. Identification of bottlenecks to full-fledged electrical freight and passenger mobility



# Cluster 5 – Review and monitoring of emerging issues

## Electric Vehicle charging infrastructure – OUTLINE II



### III. Electrification outlook for motor-vehicles and impact on demand for charging infrastructure

- A. Steady increase of demand for electric vehicles and charging infrastructure
- B. Expected impact on the electricity grid
- C. Steady increase of demand for electric vehicle charging infrastructure

### IV. Smart charging solutions – key to successful deployment of a global EV fleet

- A. Setting the scene
- B. Innovative EV charging station solutions

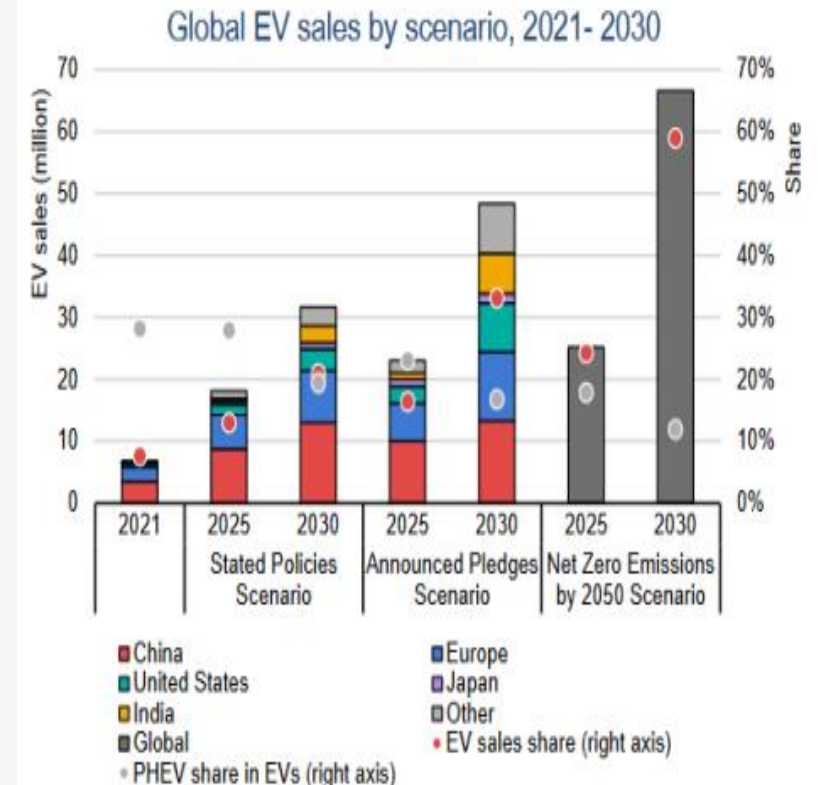

IEA. All rights reserved.

Source: IEA (2022)<sup>14</sup>

# Cluster 5 – Review and monitoring of emerging issues

## Electric Vehicle charging infrastructure – OUTLINE III



C. Innovations in battery development

D. Applicability of e-mobility for the road freight transport sector

**V. Smart EV charging requires standardized and harmonized protocols with national, regional and global applicability**

Overview of widely used charging protocols and standards

**VI. Status of preparedness for increased electrification of the vehicle fleet and next steps**

**VII. Guidance by WP.5 on a stronger role for the Committee**

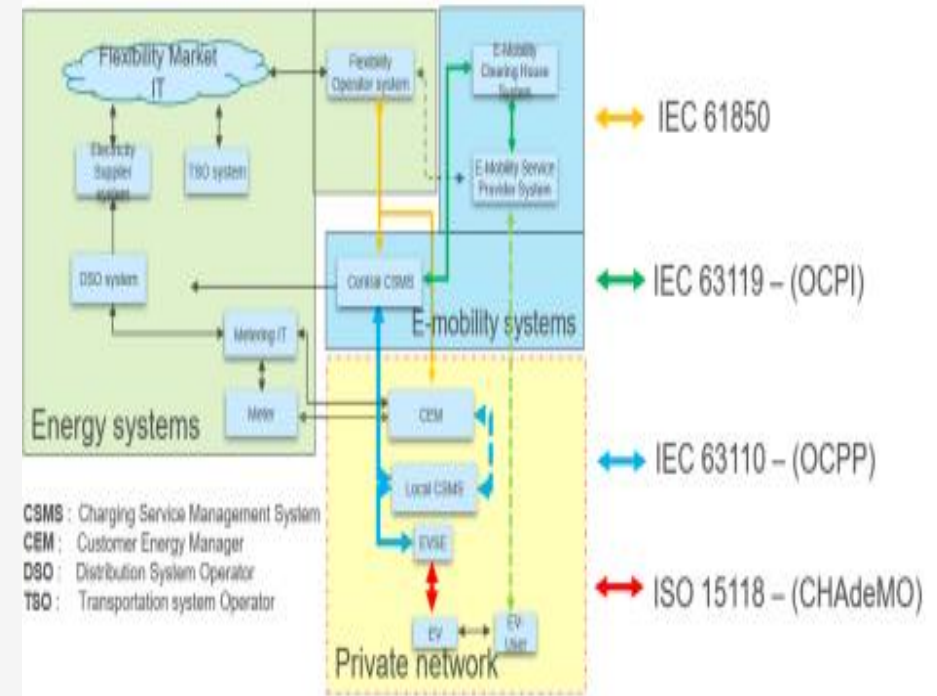

Source: EC, DG Move, 2022

# Cluster 5 – Review and monitoring of emerging issues

## Electric Vehicle charging infrastructure – NEXT STEPS



UNECE

**WP.5:** will establish a steady workflow on general trends surrounding passenger EVs:

- 2022-2023 biennial publication to focus on EV charging infrastructure [adopted]
- Conduct a workshop on cyber threats and EVSE [adopted]
- Consider accessibility and affordability of charging at EVSE and its integration in the e-grid [adopted]

**WP.24:** decided to consider as part of its work scope commercial EV fleets including eLDVs and eHDVs and their charging infrastructure in the context of inter-modal transport [adopted]

**WP.6:** stands ready to consider data collection on EVs and EVSE by developing, where required, data definitions and by setting up a specific data collection mechanism covering both the grid as well as the vehicle side [adopted]

# Cluster 5 – Review and monitoring of emerging issues

## Electric Vehicle charging infrastructure – FOR CONSIDERATION BY ITC



**WP.29:** *“The Committee may wish to invite WP.29 to make proposals on possible future activities on regulatory tools for harmonized communication between vehicles and EVSE, taking into consideration already existing related standards and protocols” and “Given the cross-sectoral nature of the topic at hand, the Committee may wish to consider engaging more closely its sister ECE Committee on Sustainable Energy on these matters”*

**SC.1:** *“The Committee may wish to invite SC.1 to consider and make proposals on road transport developments in view of the electrification of LDVs and HDVs and how to best arrange the development of charging infrastructure”*

**WP.5 stands ready to continue playing a coordinating role!**



# Cluster 6 – Inland transport security

## Workshop on protection of transport infrastructure



- WP.5 hosted the **2022 UNECE Transport Security Discussion Forum**
- Thematic focus: **Protection of transport infrastructure at the stages of design, construction and operation**
- Workshop material available at the [UNECE website](#)
- 2023 focus: **Cyber threats to Electric Vehicle Charging Systems (EVCS)**





## Actions of the inland transport sector to join the global fight against climate change

85<sup>th</sup> Session

**INLAND TRANSPORT COMMITTEE**



**UNECE**

# Thank you!

Mrs. Els de Wit  
Chair, WP.5 (NL)

**UNECE**

Date 22 | 02 | 2023, Geneva